

# NOTICE

- \* Please make sure that you have all parts indicated and they are in good condition before you begin assembly of this item. Refer to part list and hardware list below for guidance.
- \* This item should be assembled on a soft surface to prevent scratching the finish during assembly.
- \* This item may require periodic tightening.
- \* If you are having difficulty, our friendly Customer Care team is always here to help.

# PREPARATION

- \* Before beginning assembly of product, make sure all parts are present. Compare parts with part contents list and hardware contents list.
- \* If any part is missing or damaged, do not attempt to assemble the product.
- \* Estimated Assembly Time: 30 minutes.
- \* Tools Required for Assembly (included): Allen Key please adjust these highlighted ones accordingly

## Product Dimensions

42.52"x19.68"x14.96"H(Table)  
 48.82"x25.2"x25.59"H(Bench)  
 25.2"x25.2"x25.59"H(Chair)

# CARE AND MAINTENANCE

Store outdoor furniture indoors or cover well when not in use. Remove wooden furniture from standing water. Dust regularly with small brush or vacuum. Spills should be taken care of immediately before they harden or stain with a slightly dampened sponge. Do not use bleach solutions

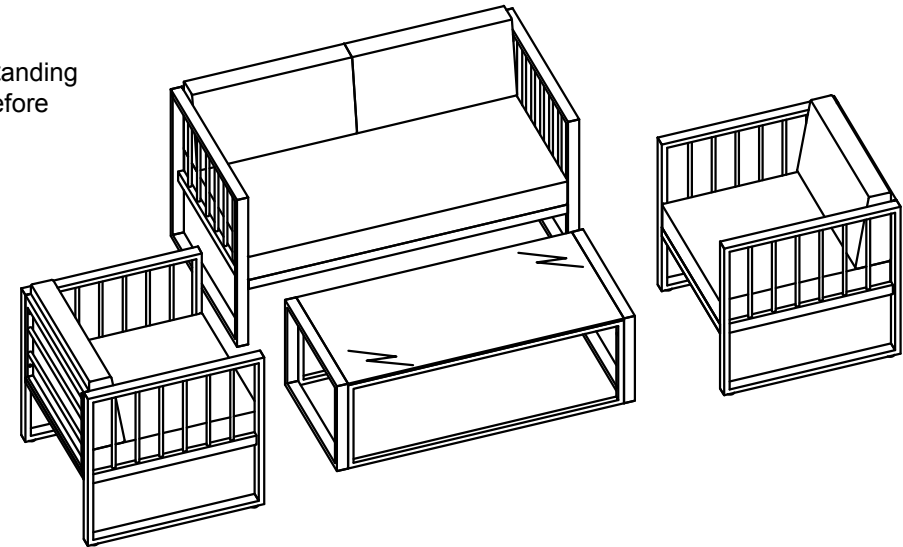

## Part List and Hardware List

PIECE	DESCRIPTION	PICTURE	QUANTITY
1	Left Leg Chair		3X
2	Right Leg Chair		3X
3	Seat Bench Frame		1X
4	Back Bench Frame		1X
5	Seat Chair Frame		2X
6	Back Bench Frame		2X
7	Leg Table		2X
8	Frame Table		2X
9	Support Table		1X
10	Glass		1X
CSH1	Seat Bench Cushion		1X
CSH2	Seat Chair Cushion		2X
CSH3	Back Bench Cushion		2X

PIECE	DESCRIPTION	PICTURE	QUANTITY
CSH4	Back Chair Cushion		2X
HW1	Allen Bolt: M6 x 0.5 x 35 mm		45X
HW2	Allen Bolt: M6 x 0.5 x 15 mm		4X
HW3	Flat washer: M6 x 1 mm		49X
HW4	Allen Key		2X



Weight Capacity : 125 lbs ( table )  
 250 lbs (single seat )  
 750 lbs (three person seat )  
 Warning : Do not stand on table/Bench  
 Warning : Do not over torque bolts/screws

# PREPARATION

- \* Before beginning assembly of product, make sure all parts are present. Compare parts with part contents list and hardware contents list.
- \* If any part is missing or damaged, do not attempt to assemble the product.
- \* Estimated Assembly Time: 30 minutes.
- \* Tools Required for Assembly (included): Allen Key
- \* If you are having difficulty, our friendly Customer Care team is always here to help.

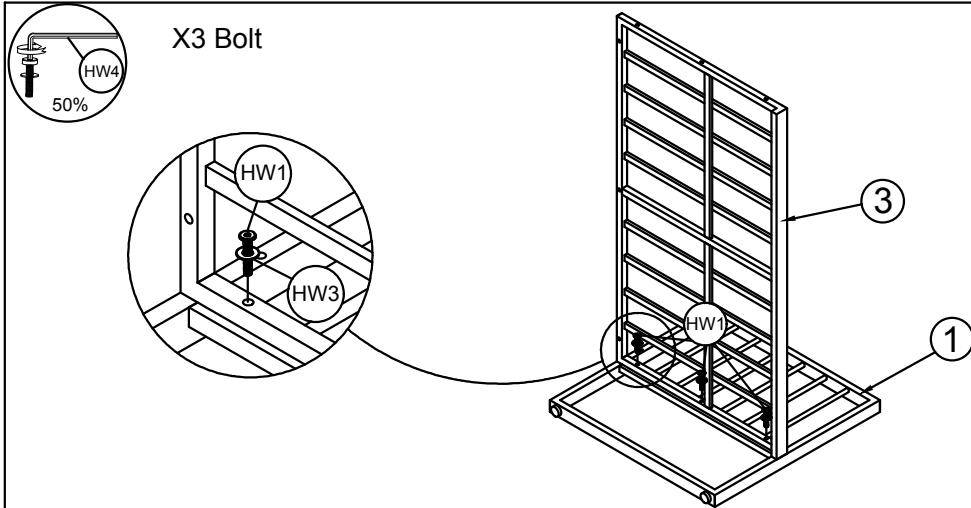

STEP 1: Connect Seat Bench Frame (3) & Left Leg Chair (1) by tighten Allen Bolt (HW1), Flat Washer (HW3) with Allen Key (HW4).

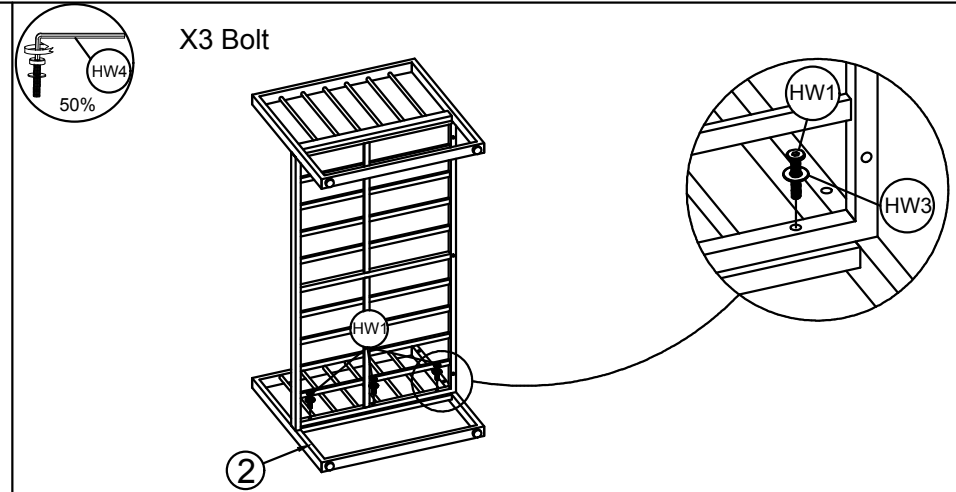

STEP 2: Connect the part from Step 1 & Right Leg Chair (2) by tighten Allen Bolt (HW1), Flat Washer (HW3) with Allen Key (HW4).

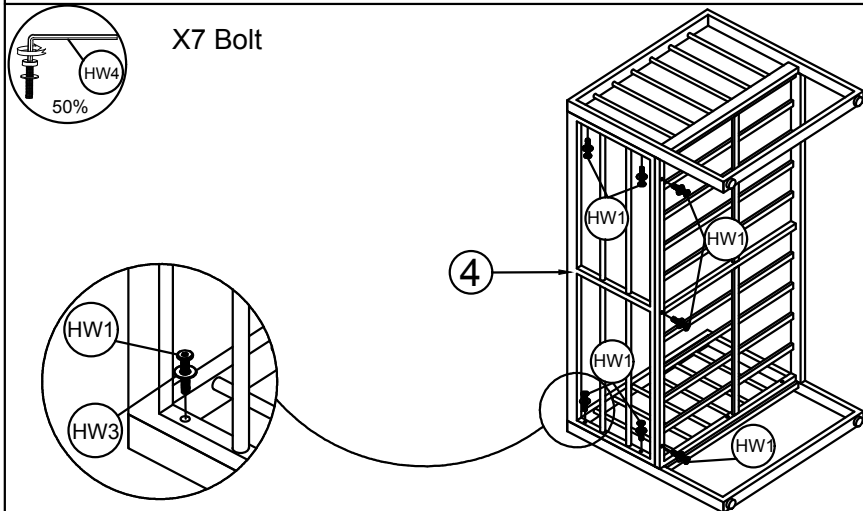

STEP 3: Connect the part from Step 2 & Back Bench Frame (4) by tighten Allen Bolt (HW1), Flat Washer (HW3) with Allen Key (HW4).

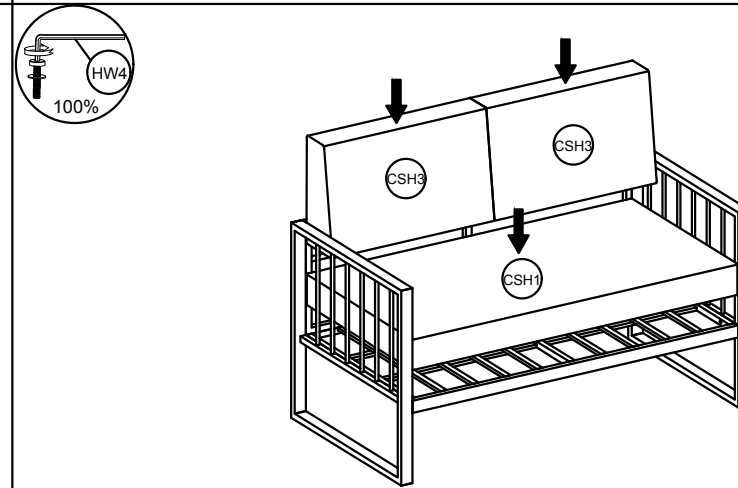

STEP 4: Put Seat Cushion (CSH1) & Back Cushion (CSH3) to Finish Bench.

# PREPARATION

- \* Before beginning assembly of product, make sure all parts are present. Compare parts with part contents list and hardware contents list.
- \* If any part is missing or damaged, do not attempt to assemble the product.
- \* Estimated Assembly Time: 30 minutes.
- \* Tools Required for Assembly (included): Allen Key
- \* If you are having difficulty, our friendly Customer Care team is always here to help.

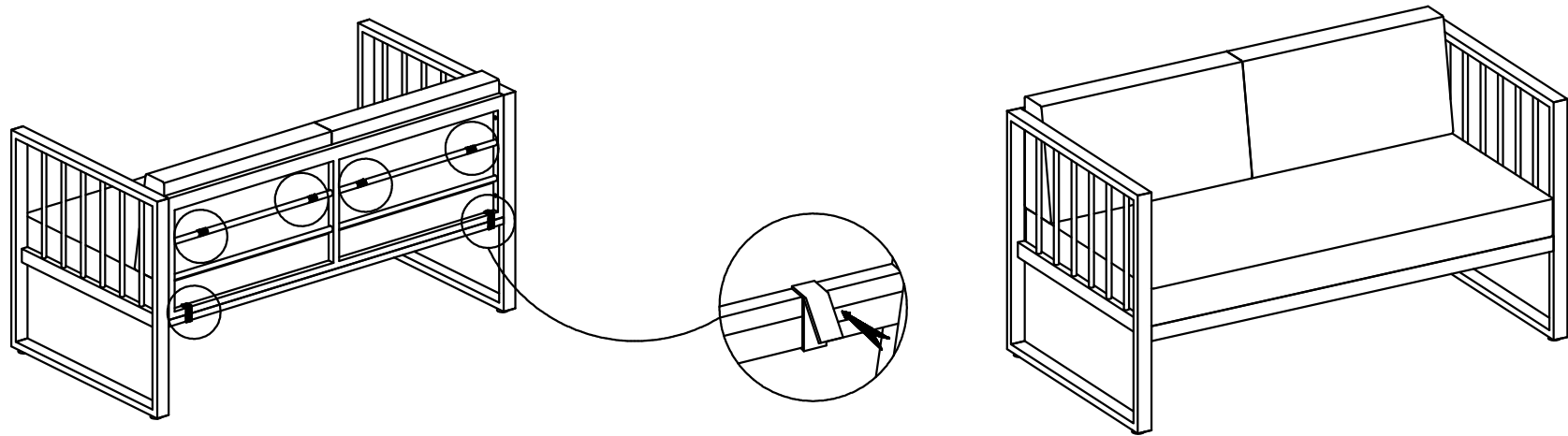

STEP 5: Finish Bench.

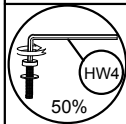

X3 Bolt

X2

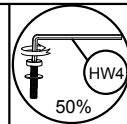

X3 Bolt

X2

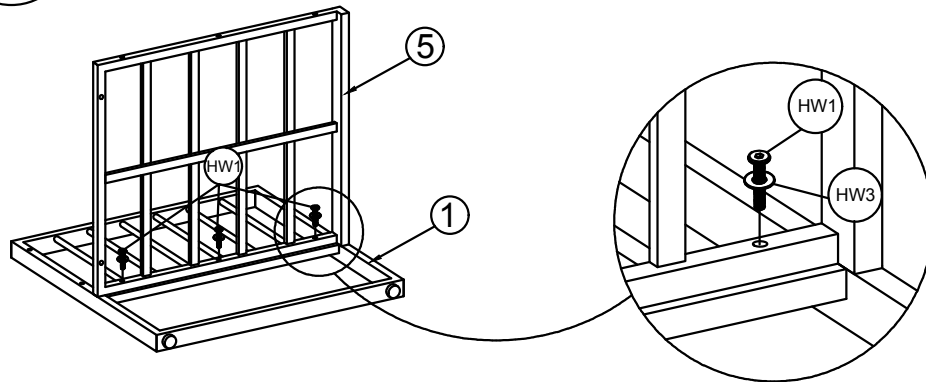

STEP 6: Connect Left Leg Chair (1) & Seat Chair Frame (5) by tighten Allen Bolt (HW1), Flat Washer (HW3) with Allen Key (HW4).

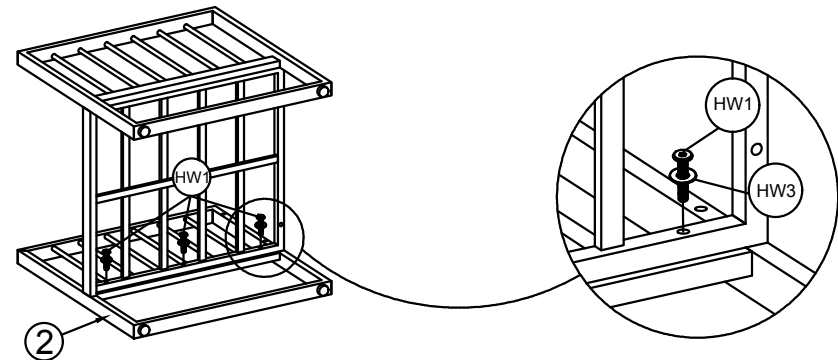

STEP 7: Connect the part from Step 6 & Right Leg Chair (2) by tighten Allen Bolt (HW1), Flat Washer (HW3) with Allen Key (HW4).

## PREPARATION

- \* Before beginning assembly of product, make sure all parts are present. Compare parts with part contents list and hardware contents list.
- \* If any part is missing or damaged, do not attempt to assemble the product.
- \* Estimated Assembly Time: 30 minutes.
- \* Tools Required for Assembly (included): Allen Key
- \* If you are having difficulty, our friendly Customer Care team is always here to help.

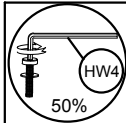

X6 Bolt

X2

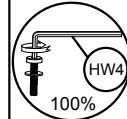
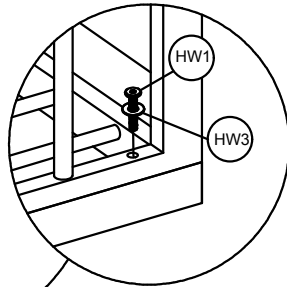
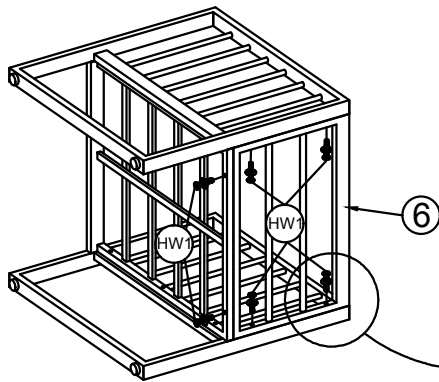

X2

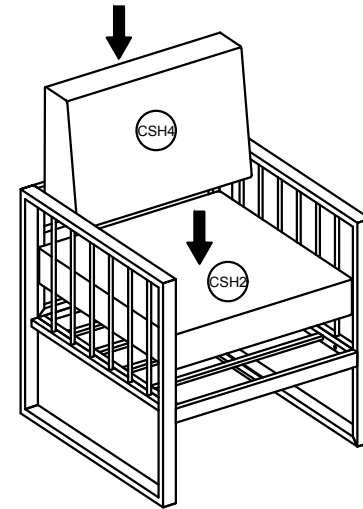

STEP 8: Connect the part from Step 7 & Back Chair Frame (6) by tighten Allen Bolt (HW1), Flat Washer (HW3) with Allen Key (HW4).

STEP 9: Put Seat Cushion (CSH2) & Back Cushion (CSH4) to Finish Chair.

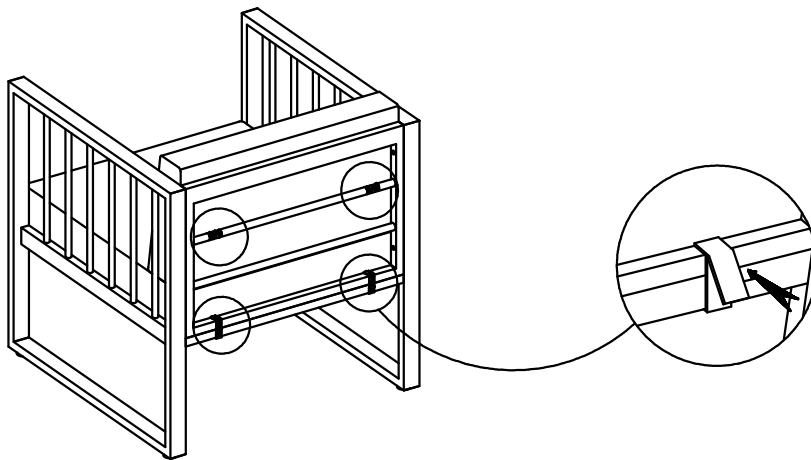

X2

STEP 10: Finish Chair.

# PREPARATION

- \* Before beginning assembly of product, make sure all parts are present. Compare parts with part contents list and hardware contents list.
- \* If any part is missing or damaged, do not attempt to assemble the product.
- \* Estimated Assembly Time: 30 minutes.
- \* Tools Required for Assembly (included): Allen Key
- \* If you are having difficulty, our friendly Customer Care team is always here to help.

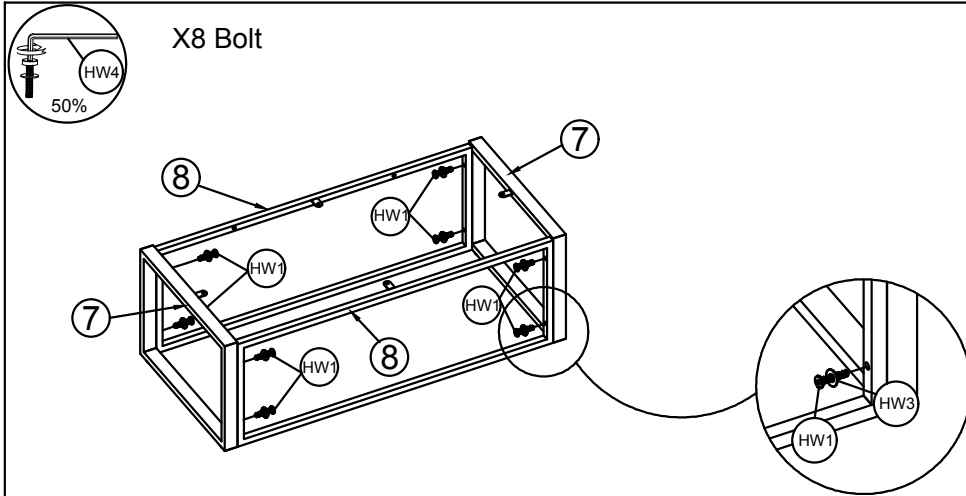

STEP 11: Connect Leg Table (7) & Frame Table (8) by tighten Allen Bolt (HW1), Flat Washer (HW3) with Allen Key (HW4).

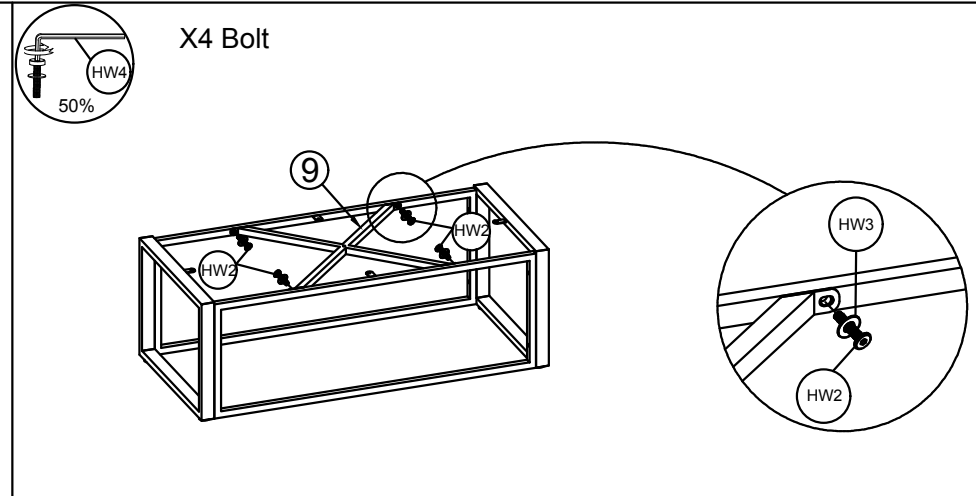

STEP 12: Connect the part from Step 11 & Support Table (9) by tighten Allen Bolt (HW2), Flat Washer (HW3) with Allen Key (HW4).

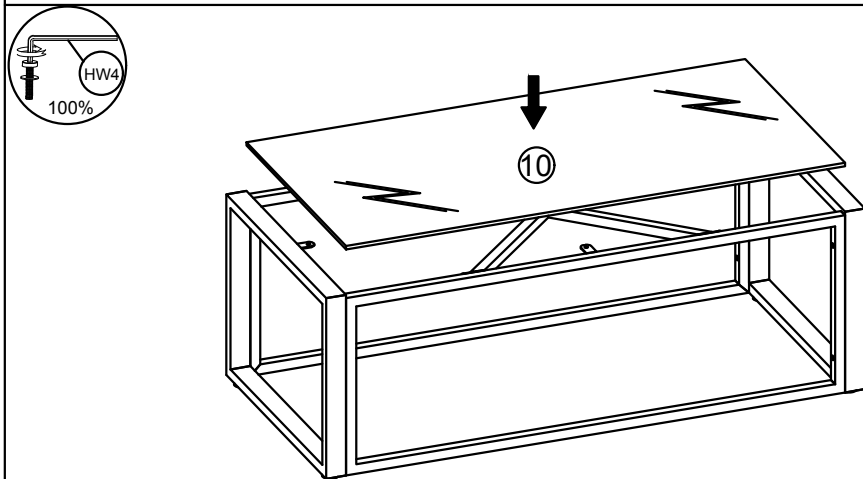

STEP 13: Put Glass (10) on the Table to Finish

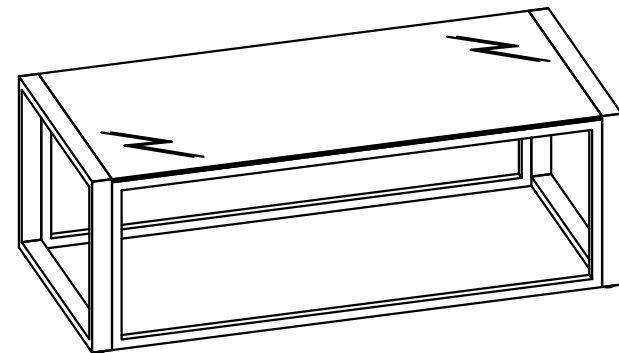

STEP 14: Finish