

Kitchen Island Cart

Assembly Instructions - Please keep for future reference

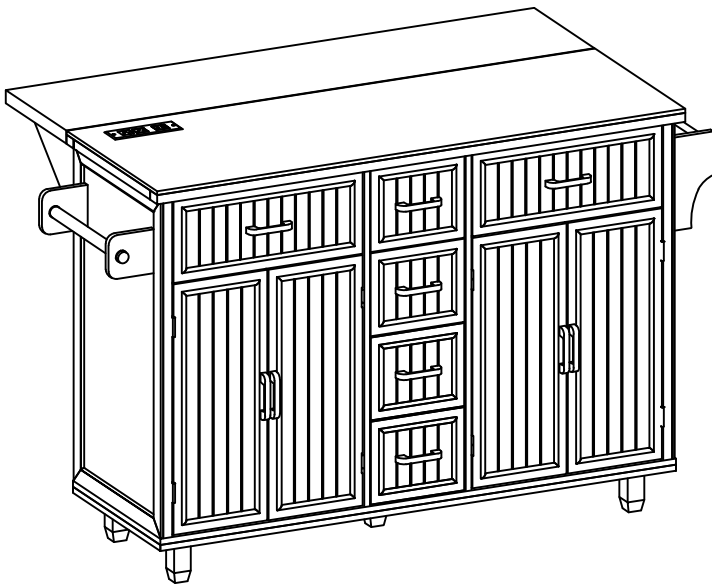

OPTION WITH THE FEET

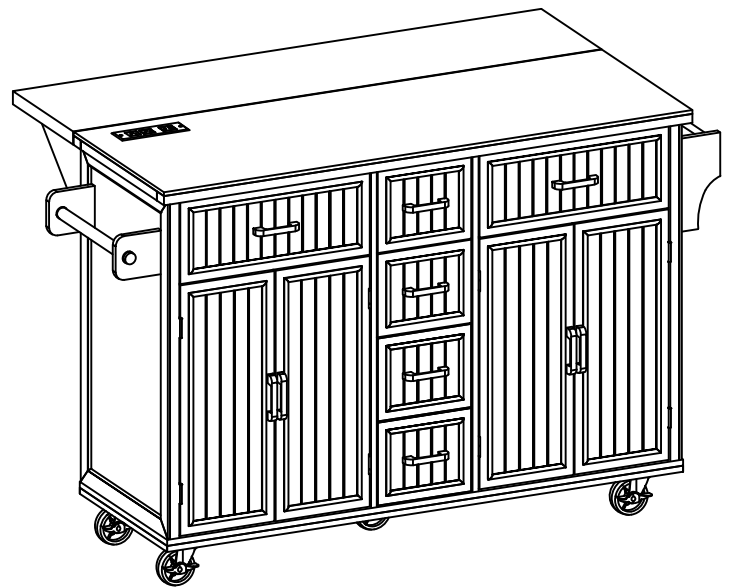

OPTION WITH THE WHEELS

Important - Please read these instructions fully before starting assembly



Safety and Care Advice

Important – Please read these instructions fully before starting assembly

- Check you have all the components and tools listed on the following pages.
- Remove all fittings from the plastic bags and separate them into their groups.
- Keep children and animals away from the work area, small parts could choke if swallowed.
- Make sure you have enough space to layout the parts before starting.

- During assembly do not stand or put weight on the product, this could cause damage.
- Assemble the item as close to its final position (in the same room) as possible.
- Assemble on a soft level surface to avoid damaging the unit or your floor.
- Parts of the assembly will be easier with 2 people.



- To reduce the likelihood of damaging your product please ensure that your power drill is set on a low torque setting.

Care and maintenance

- Only clean using a damp cloth and mild detergent, do not use bleach or abrasive cleaners.
- From time to time check that there are no loose screws on this unit.
- This product should not be discarded with household waste. Take to your local authority waste disposal centre.

Handy Hints

- Assemble all parts and bolts loosely during assembly, only once the product is complete should you fully tighten the bolts
- Regularly check and ensure that all bolts and fittings are tightened properly.

WARNING
In order to help prevent overturning – please follow these instructions

To help prevent product toppling over please follow the below steps:-







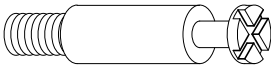
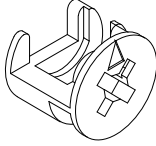
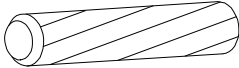

- Use the anti tip stap or wall fixing method provided (if applicable)
- Do not allow children to climb or hang on the furniture
- Do not open more than one drawer at a time
- Do not place heavy items in the top drawers
- Do not place heavy items on top of the furniture, unless the furniture has been designed for this purpose

Components - Fittings

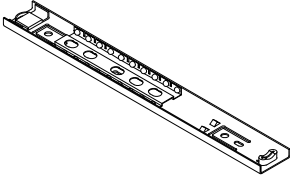
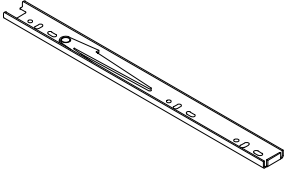
Please check you have all the panels listed below

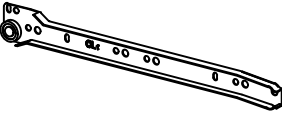
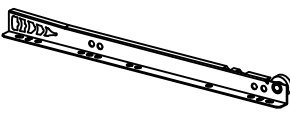
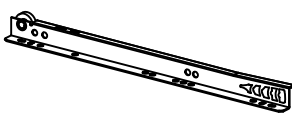
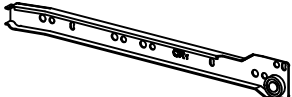
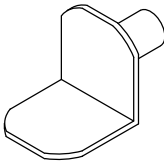
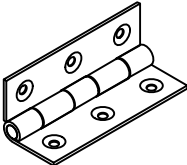
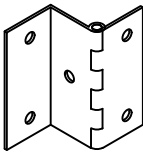
Note: The quantities below are the correct amount to complete the assembly. In some cases, more fittings may be supplied than required.

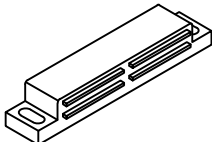
HARDWARE BOX INSIDE BOX 1

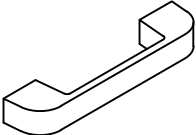
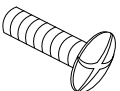
<p>A QTY: 32</p> 	<p>B QTY: 32</p> 	<p>C QTY: 10</p>  <p>Ø8*30mm</p>	<p>D QTY: 24</p>  <p>Ø6*12mm</p>
CAM BOLT	CAM LOCK	WOOD DOWEL	FLAT HEAD SCREW
<p>E QTY: 122</p>  <p>Ø6*12mm</p>	<p>F1 QTY: 4</p> 	<p>F2 QTY: 4</p> 	<p>G QTY: 4</p> 
FLAT HEAD SCREW	BALL BEARING GLIDE	BALL BEARING GLIDE	RUBBER STOPPER
<p>CL QTY: 3</p> 	<p>DL QTY: 3</p> 	<p>DR QTY: 3</p> 	<p>CR QTY: 3</p> 
ROLLER RUNNER	ROLLER RUNNER	ROLLER RUNNER	ROLLER RUNNER
<p>H QTY: 8</p> 	<p>I QTY: 7</p> 	<p>J QTY: 8</p> 	<p>K QTY: 20</p>  <p>Ø6*25mm</p>
SHELF PIN	HINGES	HINGES	FLAT HEAD SCREW
<p>L QTY: 2</p> 	<p>M QTY: 4</p> 	<p>N QTY: 10</p> 	<p>O QTY: 20</p>  <p>Ø8*15mm</p>
MAGNET	MAGNET PLATE	HANDLE	BOLT

Components - Fittings

Please check you have all the panels listed below

Note: The quantities below are the correct amount to complete the assembly. In some cases, more fittings may be supplied than required.

HARDWARE BOX INSIDE BOX 1

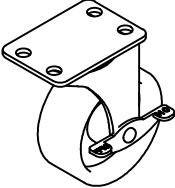
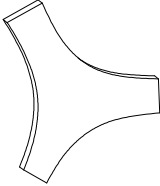
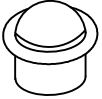
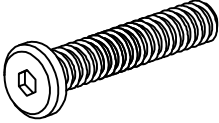
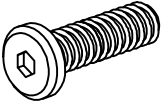
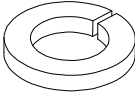
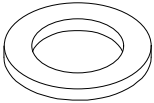
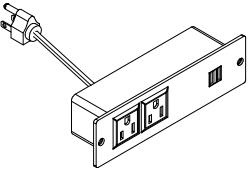
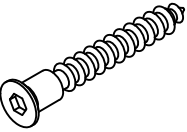
<p>P QTY: 1</p> 	<p>Q QTY: 5</p> 	<p>R QTY: 1</p> 	<p>S QTY: 2</p> 
<p>ALLEN WRENCH</p>	<p>LOCK CASTER</p>	<p>CAM TOOL</p>	<p>SPRING BALL LATCH</p>
<p>T QTY: 10</p>  <p>Ø1/4*32mm</p>	<p>U QTY: 20</p>  <p>Ø1/4*12mm</p>	<p>V QTY: 10</p> 	<p>W QTY: 10</p> 
<p>BOLT</p>	<p>BOLT</p>	<p>SPRING WASHER</p>	<p>FLAT WASHER</p>
<p>X QTY: 1</p> 	<p>Y QTY: 8</p>  <p>Ø10*45mm</p>		
<p>SOCKET</p>	<p>ALLEN FLAT HEAD SCREW</p>		

Using Camlocks

Step 1

Connect the male camlock as directed in the assembly instructions using a screwdriver.

1

DO NOT OVER TIGHTEN.
NE PAS SERRER EXCESSIVEMENT.

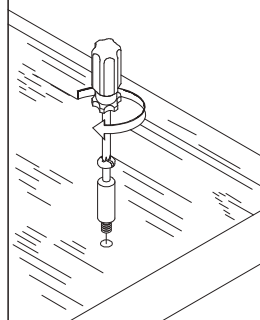

Step 2

Push the male camlock into the entry hole.

2

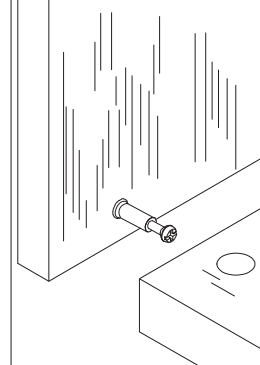

Step 3

Insert the female camlock as shown in the instruction.

Note: ensure that the arrow on the top of the camlock points towards the entry hole for the male camlock.

3

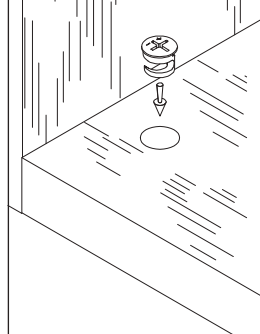

Step 4

Turn the female camlock clockwise with a screwdriver.

You should feel a click when the camlock is locked in place.

The joint is now secure.

4

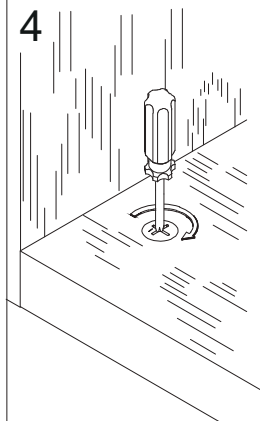

COMPONENTS - KEY DIAGRAM

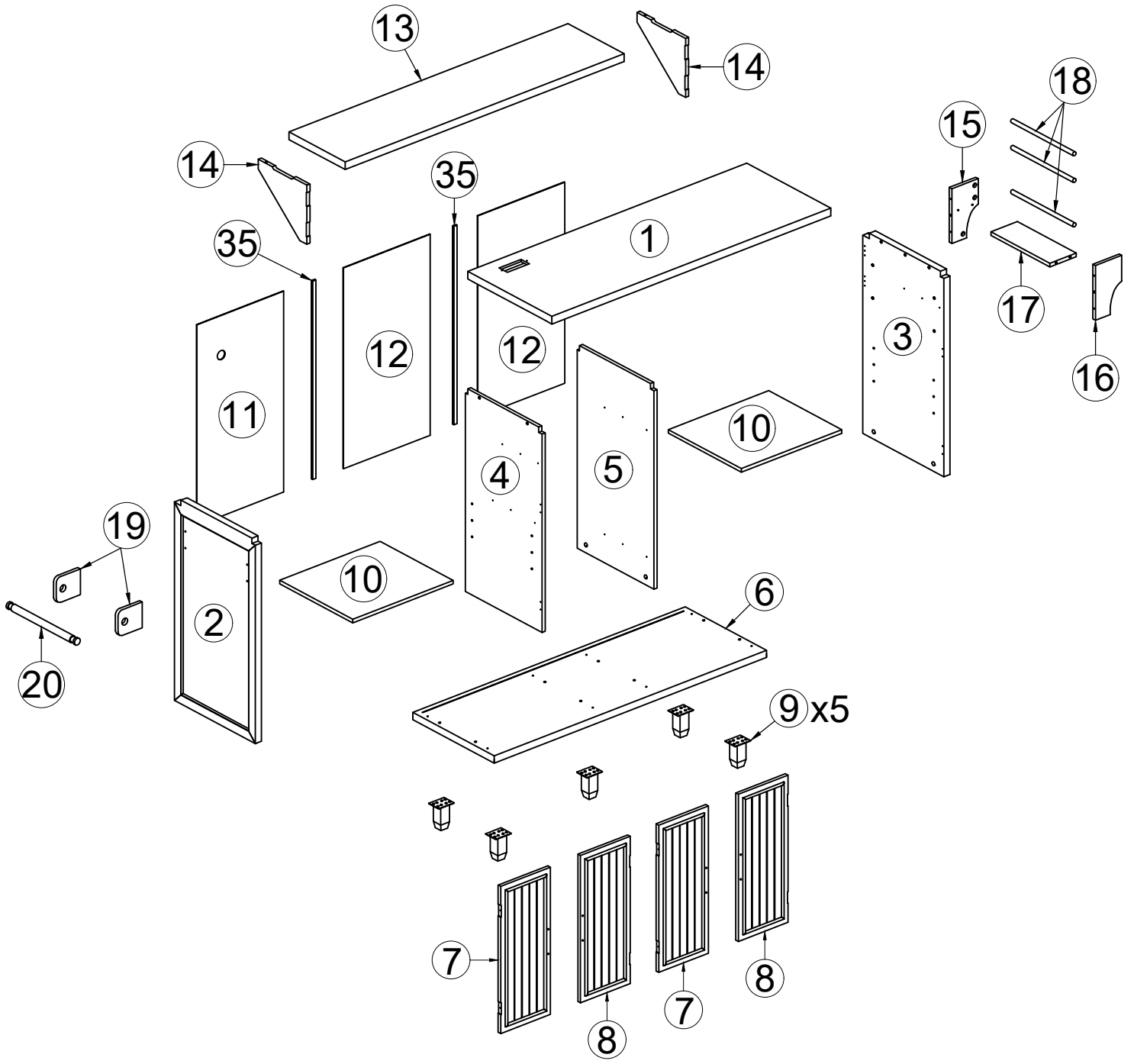

x2pcs

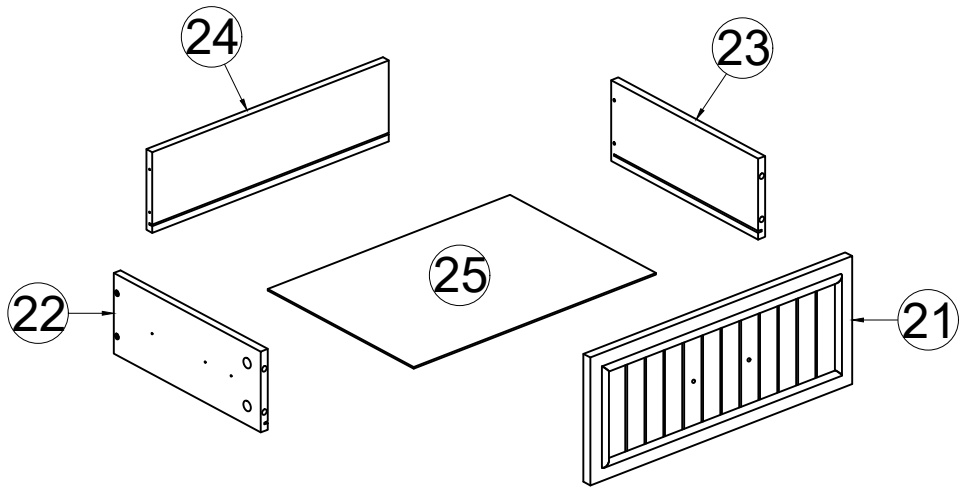

COMPONENTS - KEY DIAGRAM

x2pcs

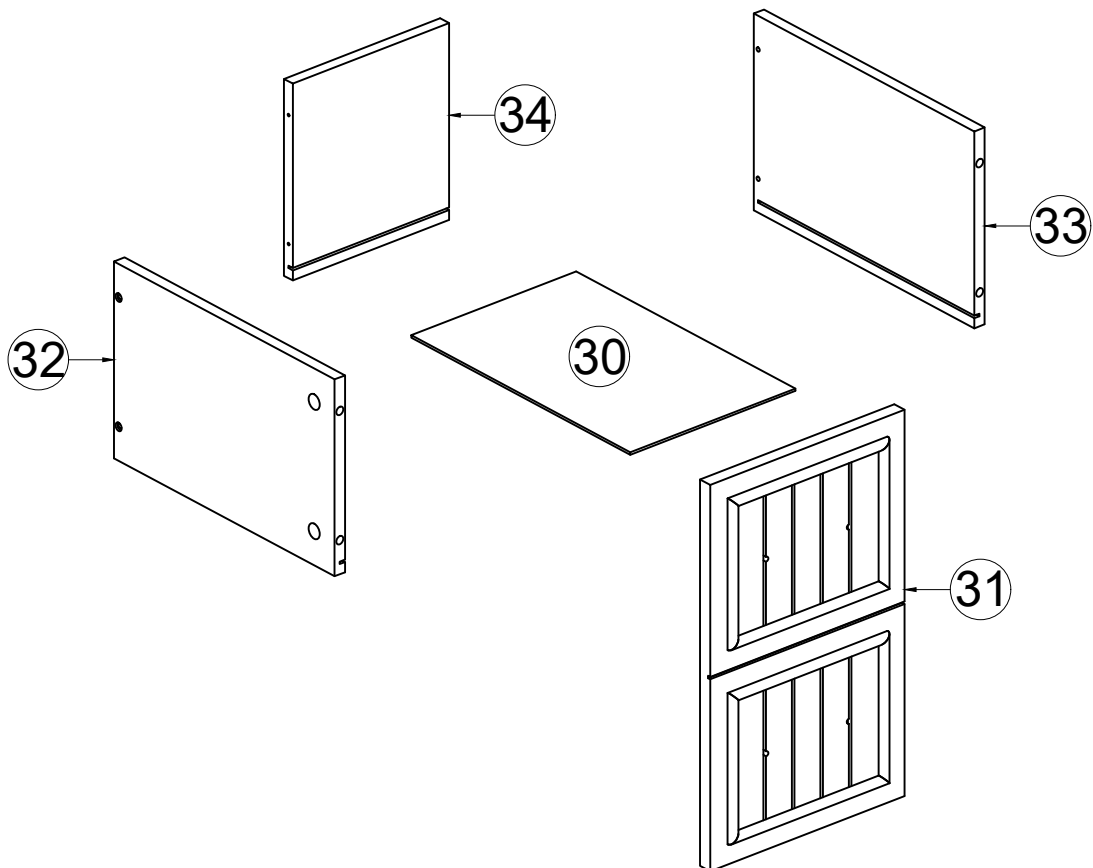
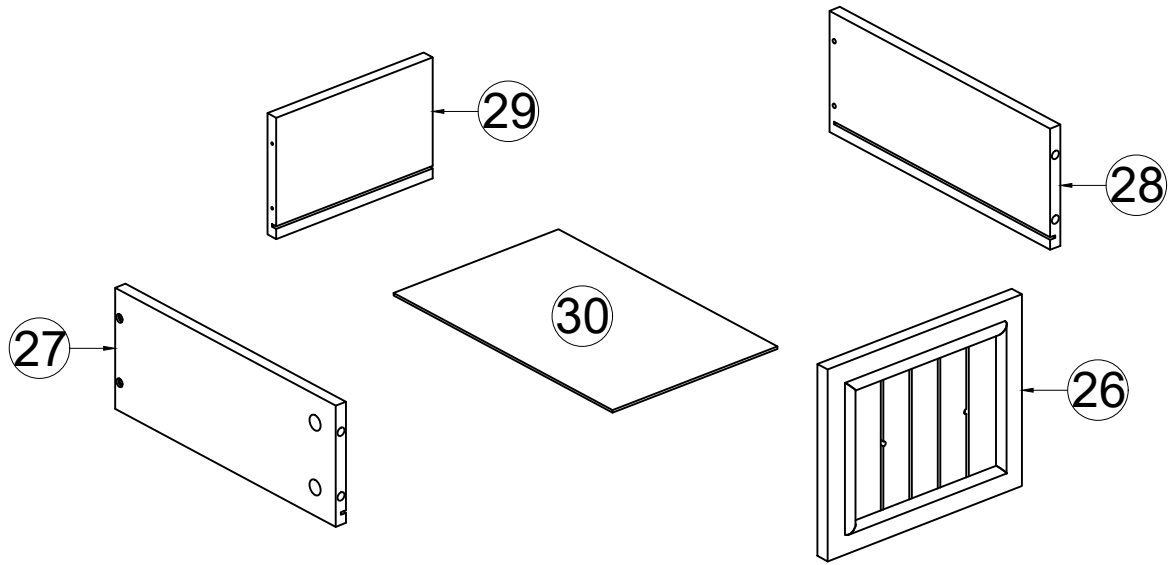

COMPONENTS - KEY DIAGRAM

BOX 1 :

1

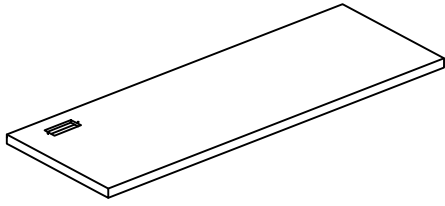

TOP PANEL

QTY: 1

6

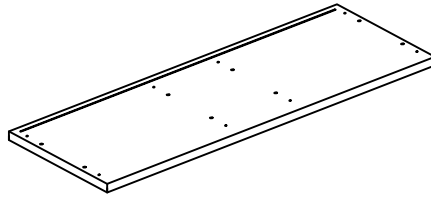

BOTTOM PANEL

QTY: 1

7

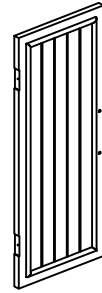

LEFT DOOR

QTY: 2

8

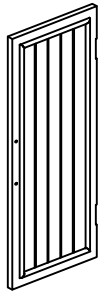

RIGHT DOOR

QTY: 2

9

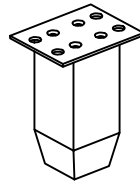

LEG

QTY: 5

10

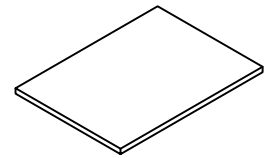

SIDE SHELF PANEL

QTY: 2

13

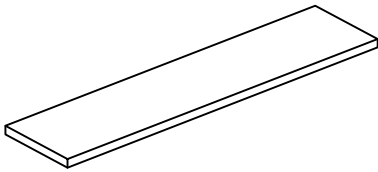

EXTENDED TOP PANEL

QTY: 1

15

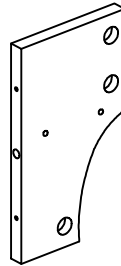

BRACKET - LEFT

QTY: 1

16

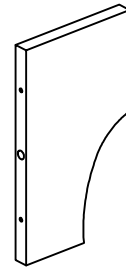

BRACKET - LEFT

QTY: 1

18

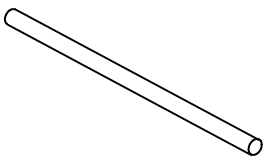

RIGHT PULL BAR

QTY: 3

19

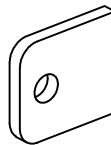

BRACKET - RIGHT

QTY: 2

22

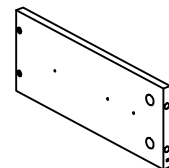

DRAWER SIDE - LARGE

QTY: 2

23

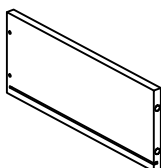

DRAWER SIDE - LARGE

QTY: 2

27

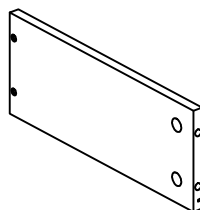

DRAWER SIDE - SMALL

QTY: 2

28

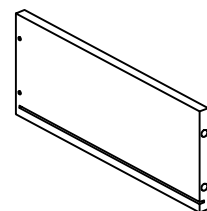

DRAWER SIDE - SMALL

QTY: 2

COMPONENTS - KEY DIAGRAM

BOX 1 :

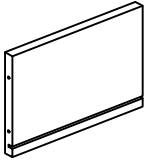
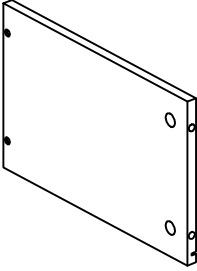
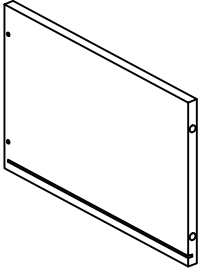
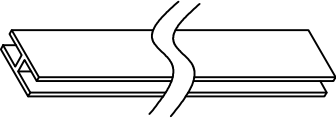
<p>29</p> 	<p>32</p> 	<p>33</p> 
<p>DRAWER BACK - SMALL QTY: 2</p>	<p>DRAWER SIDE - BOTTOM QTY: 1</p>	<p>DRAWER SIDE - BOTTOM QTY: 1</p>
<p>35</p> 		
<p>PLASTIC SPLINT QTY: 2</p>		

BOX 2 :

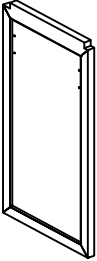
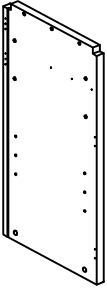
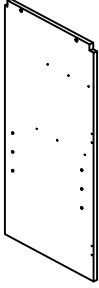
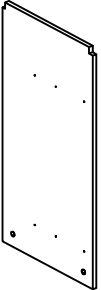
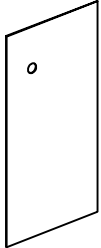
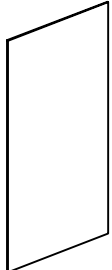
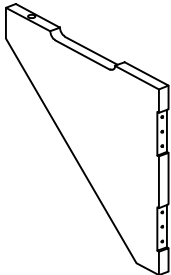
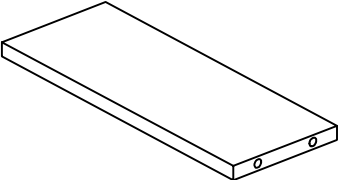
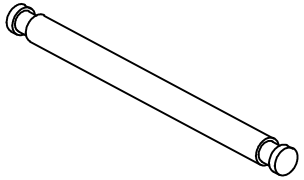
<p>2</p> 	<p>3</p> 	<p>4</p> 
<p>LEFT FRAME QTY: 1</p>	<p>RIGHT FRAME QTY: 1</p>	<p>LEFT PARTITION QTY: 1</p>
<p>5</p> 	<p>11</p> 	<p>12</p> 
<p>RIGHT PARTITION QTY: 1</p>	<p>BACK PANEL - LEFT QTY: 1</p>	<p>BACK PANEL - RIGHT QTY: 2</p>
<p>14</p> 	<p>17</p> 	<p>20</p> 
<p>EXTENDED SUPPORT QTY: 2</p>	<p>BRACKET - BOTTOM QTY: 1</p>	<p>RIGHT PULL BAR QTY: 1</p>

COMPONENTS - KEY DIAGRAM

BOX 2 :

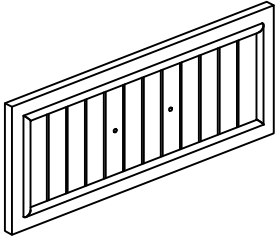
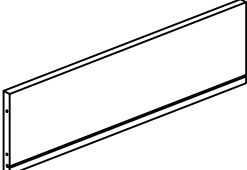
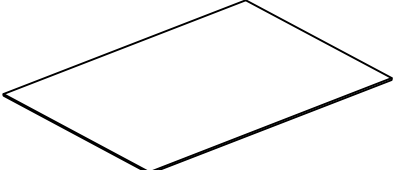
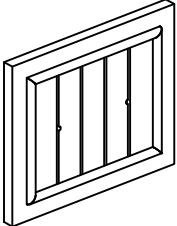
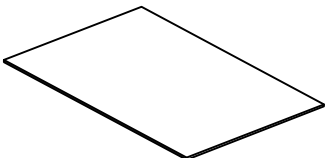
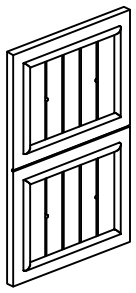
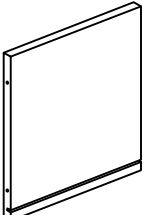
<p>21</p> 	<p>24</p> 	<p>25</p> 
<p>DRAWER FRONT - LARGE QTY: 2</p>	<p>DRAWER BACK - LARGE QTY: 2</p>	<p>DRAWER BOTTOM - LARGE QTY: 2</p>
<p>26</p> 	<p>30</p> 	<p>31</p> 
<p>DRAWER FRONT - SMALL QTY: 2</p>	<p>DRAWER BOTTOM - SMALL QTY: 3</p>	<p>DRAWER FRONT - BOTTOM QTY: 1</p>
<p>34</p> 		
<p>DRAWER BACK - BOTTOM QTY: 1</p>		

**Slides Must Be Separated Before Assembly.
After Separated, Set Aside Until Needed for Assembly.**

Las diapositivas deben separarse antes del montaje.
Después de la separación, déjelo a un lado hasta que sea necesario.

Les glissières doivent être séparées avant l'assemblage.
Après la séparation, mettez de côté jusqu'au moment de l'assemblage.

**Pay attention when connecting !
The sliding module must be at the front end.**

**STEP 1 : Extend Slide
Extender la diapositiva**

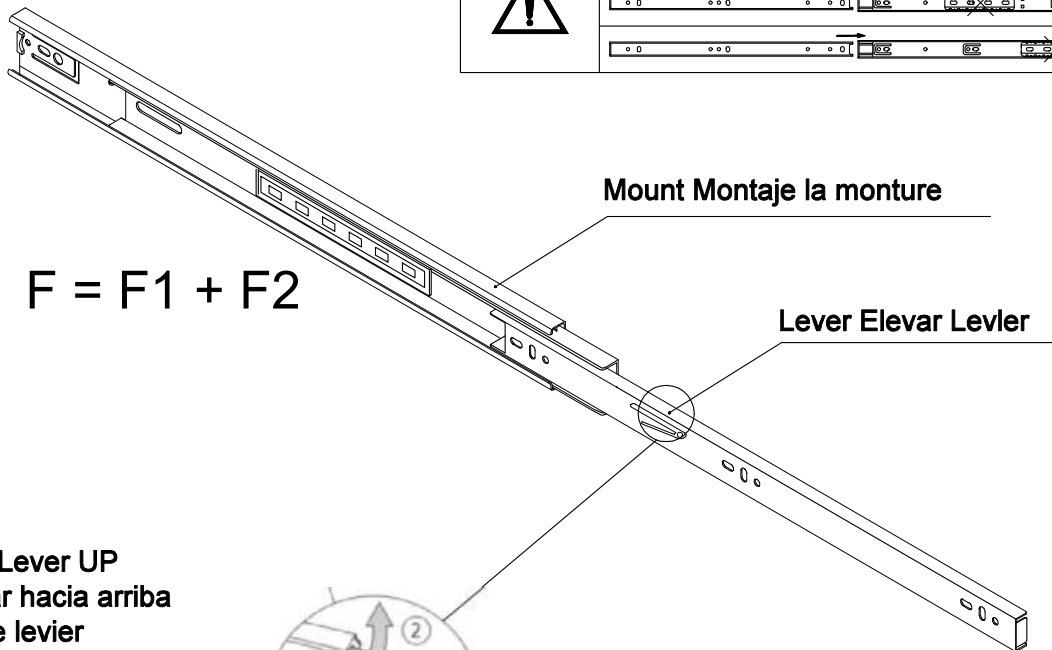

**STEP 2: Push Lever UP
Empujar hacia arriba
Lever le levier**



**Push lever for the left of drawer ,
press the lever for the right of drawer.**

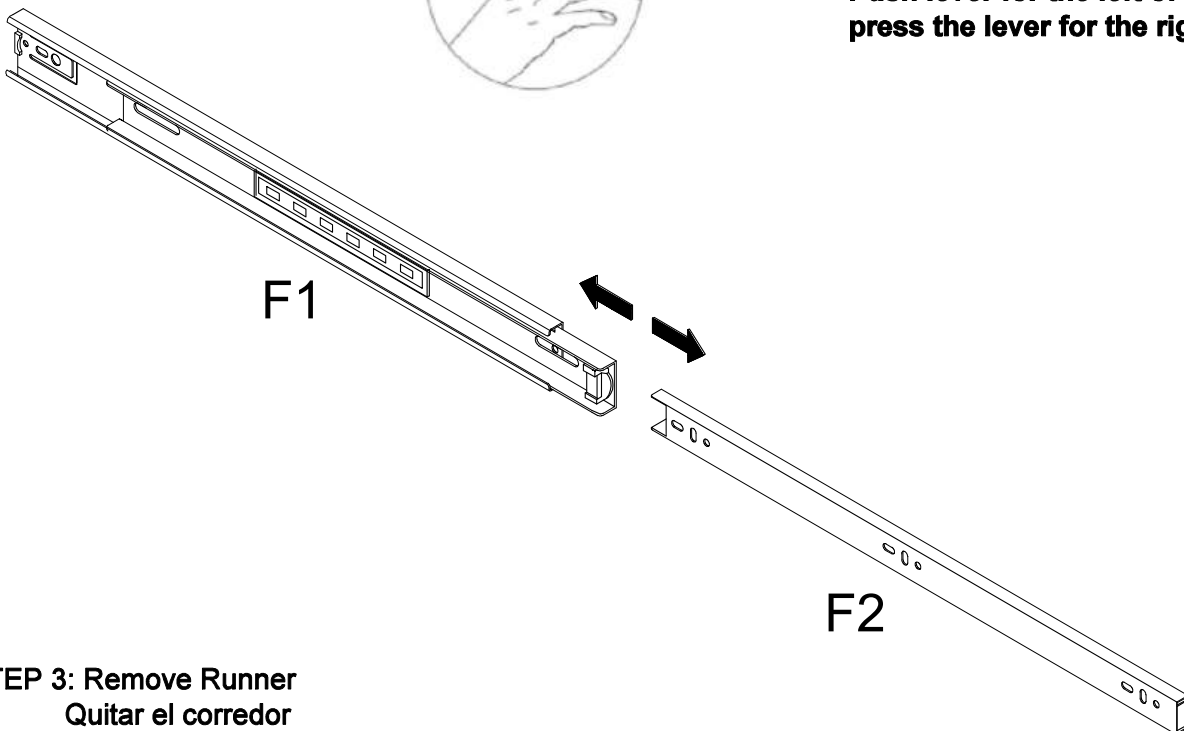

**STEP 3: Remove Runner
Quitar el corredor
Enever le coureur**

ASSEMBLY INSTRUCTIONS

STEP 1

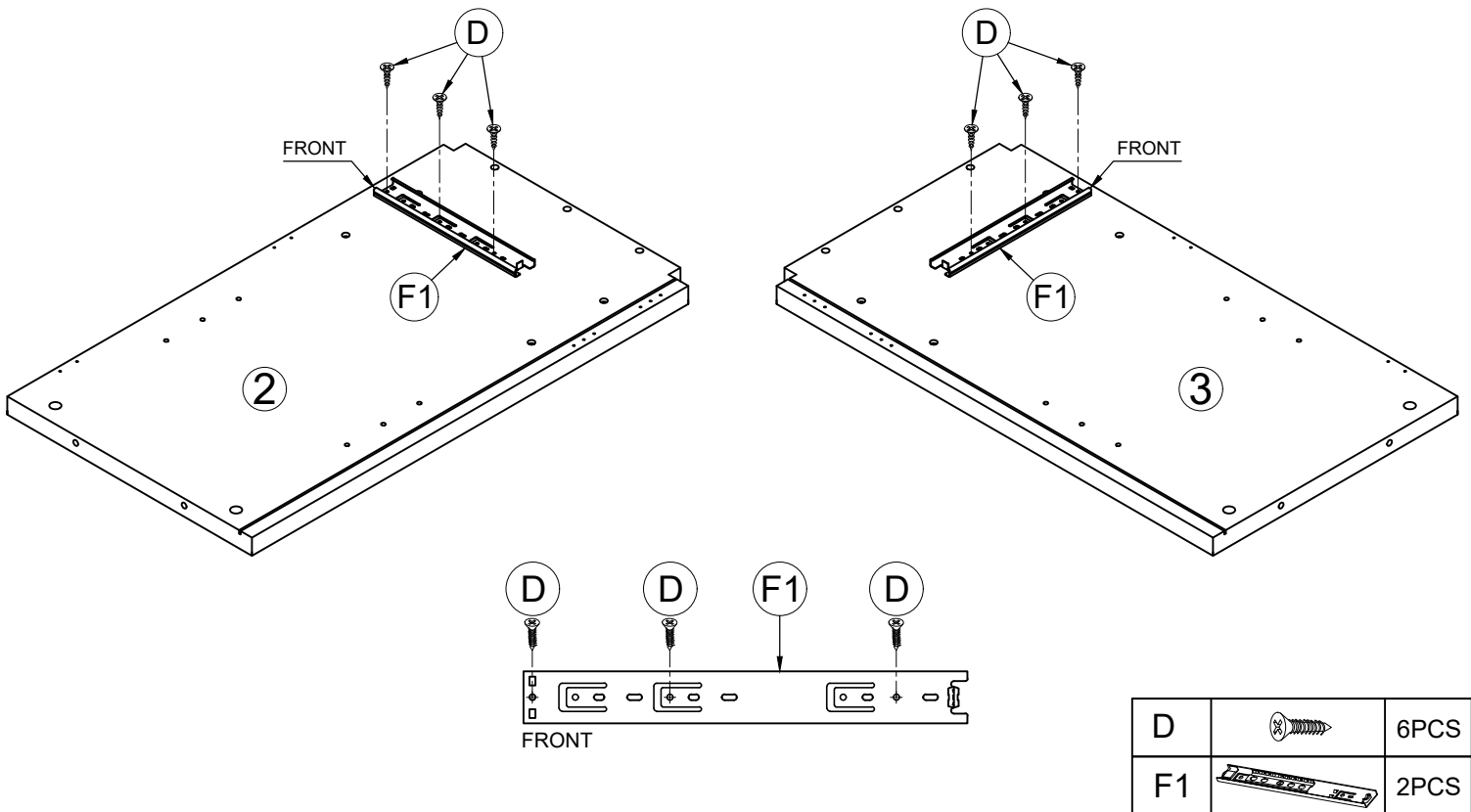

STEP 2

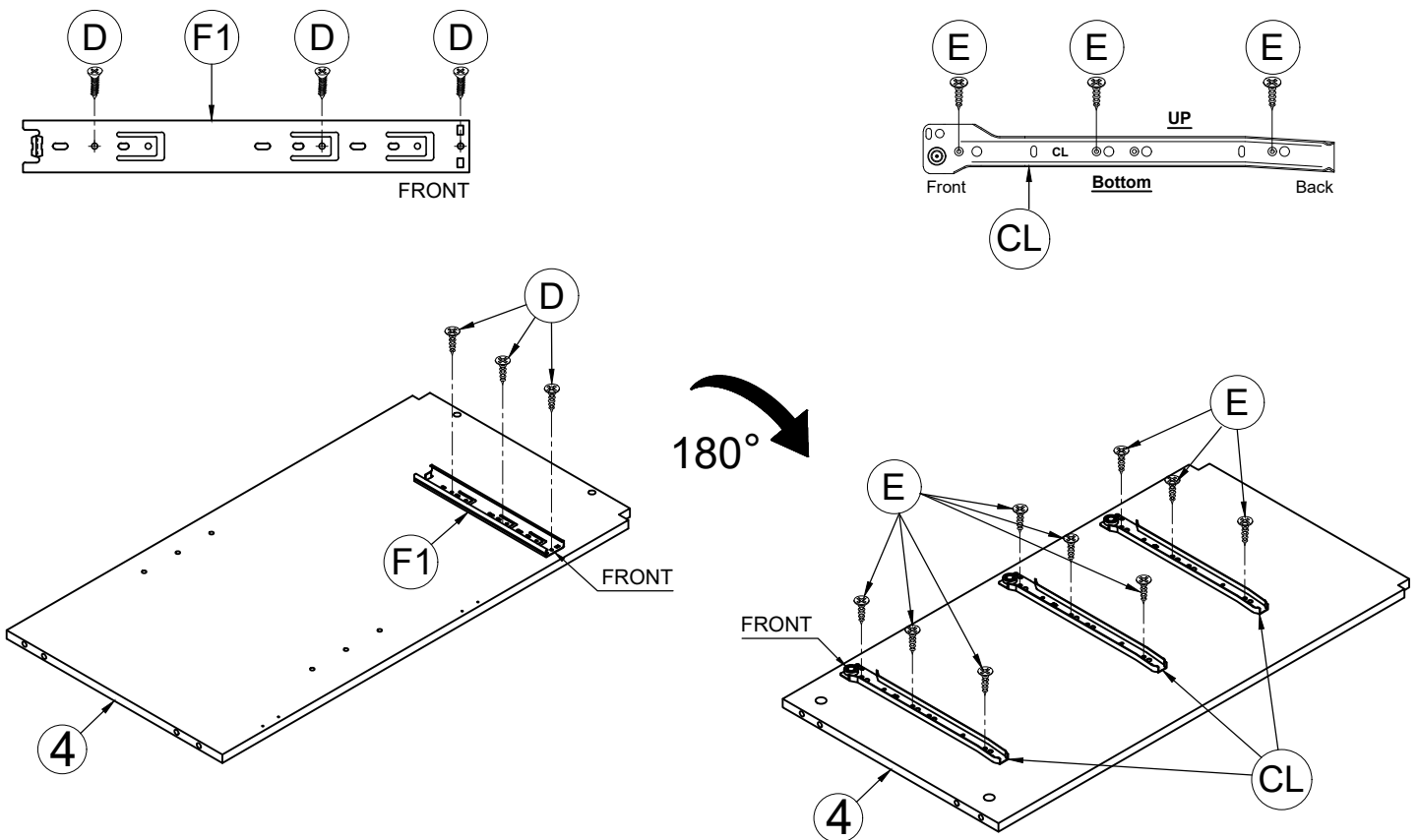



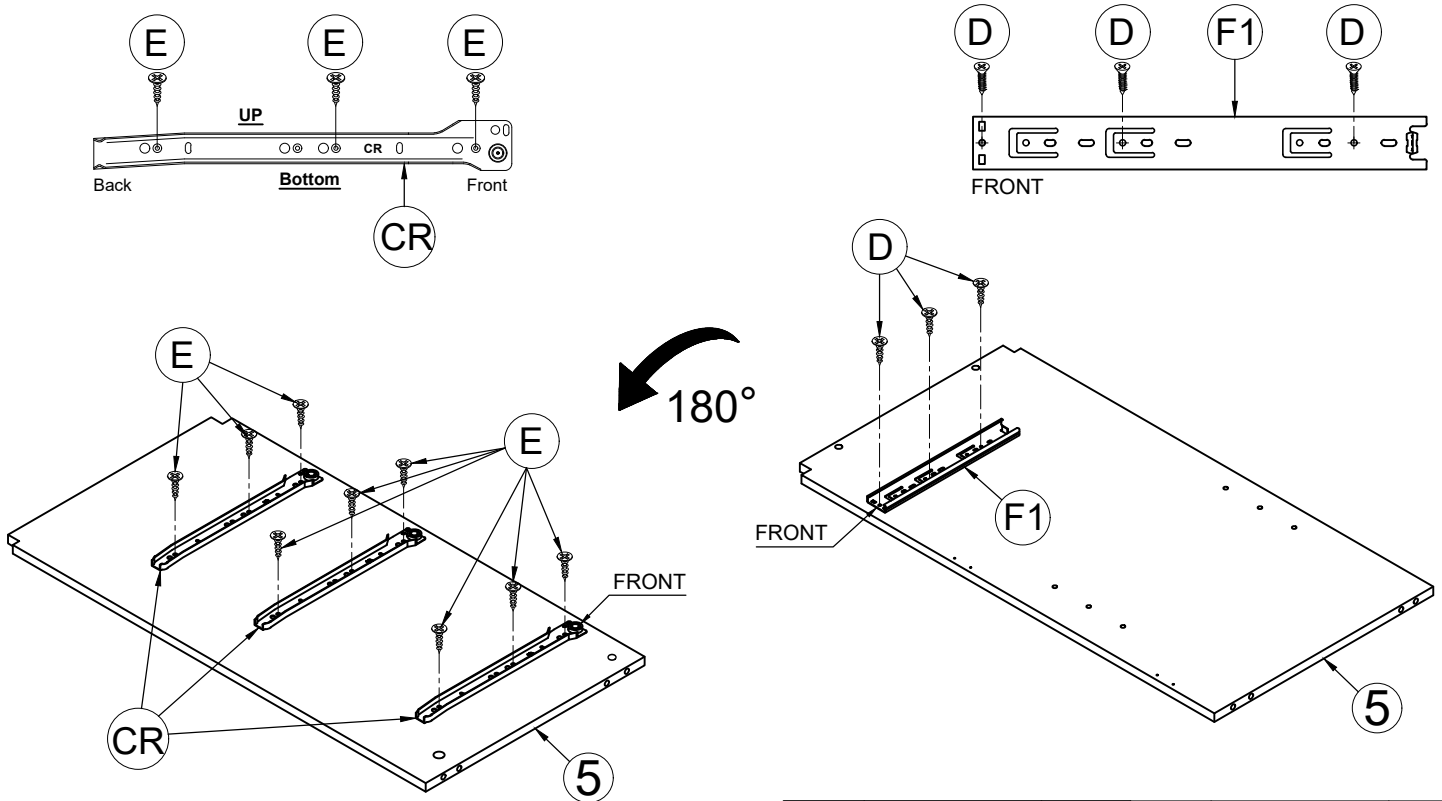

D		3PCS	E		9PCS
F1		1PC	CL		3PCS

ASSEMBLY INSTRUCTIONS



STEP 3

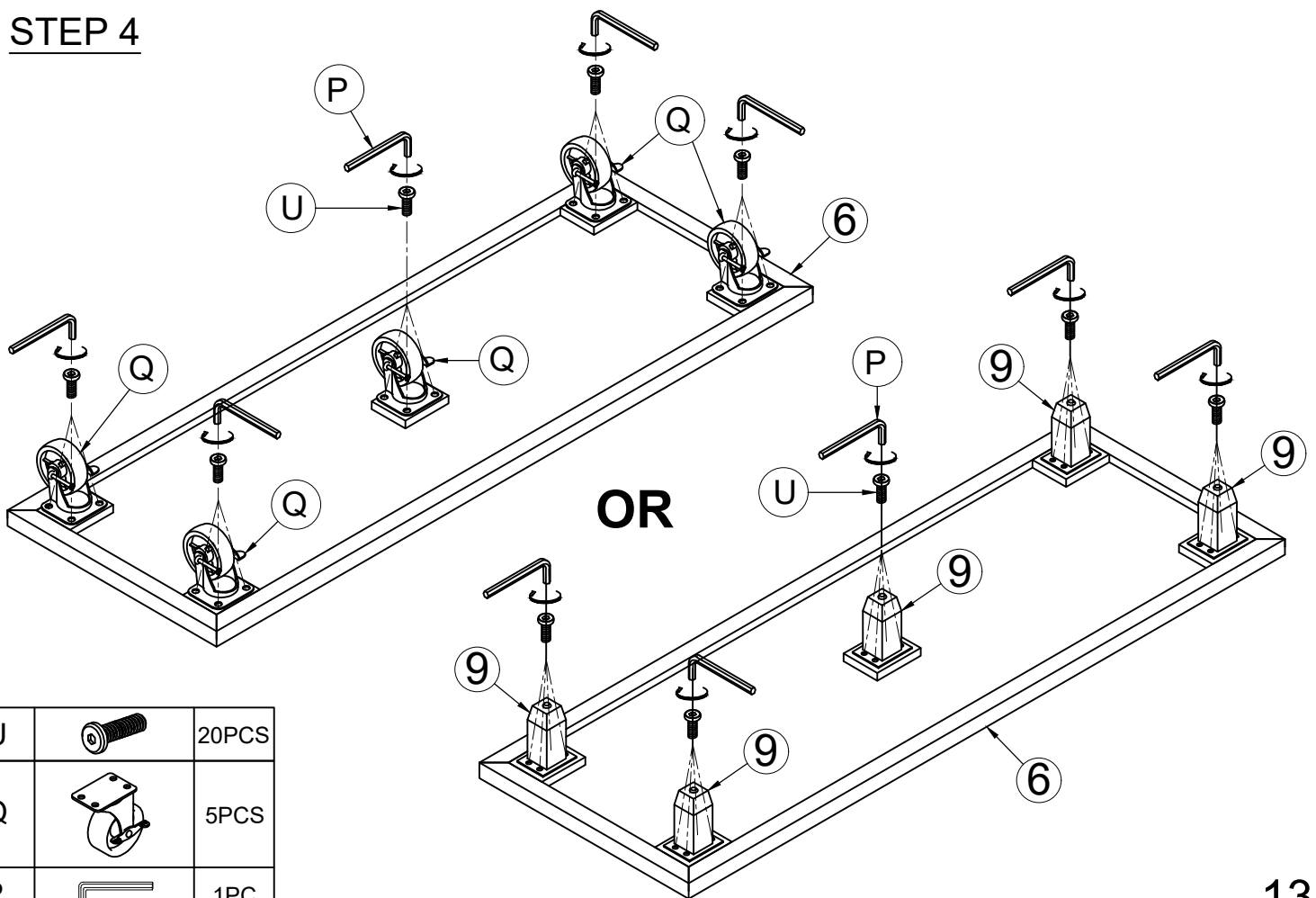

D		3PCS	F1		1PC
E		9PCS	CR		3PCS

STEP 4





U		20PCS
Q		5PCS
P		1PC

ASSEMBLY INSTRUCTIONS

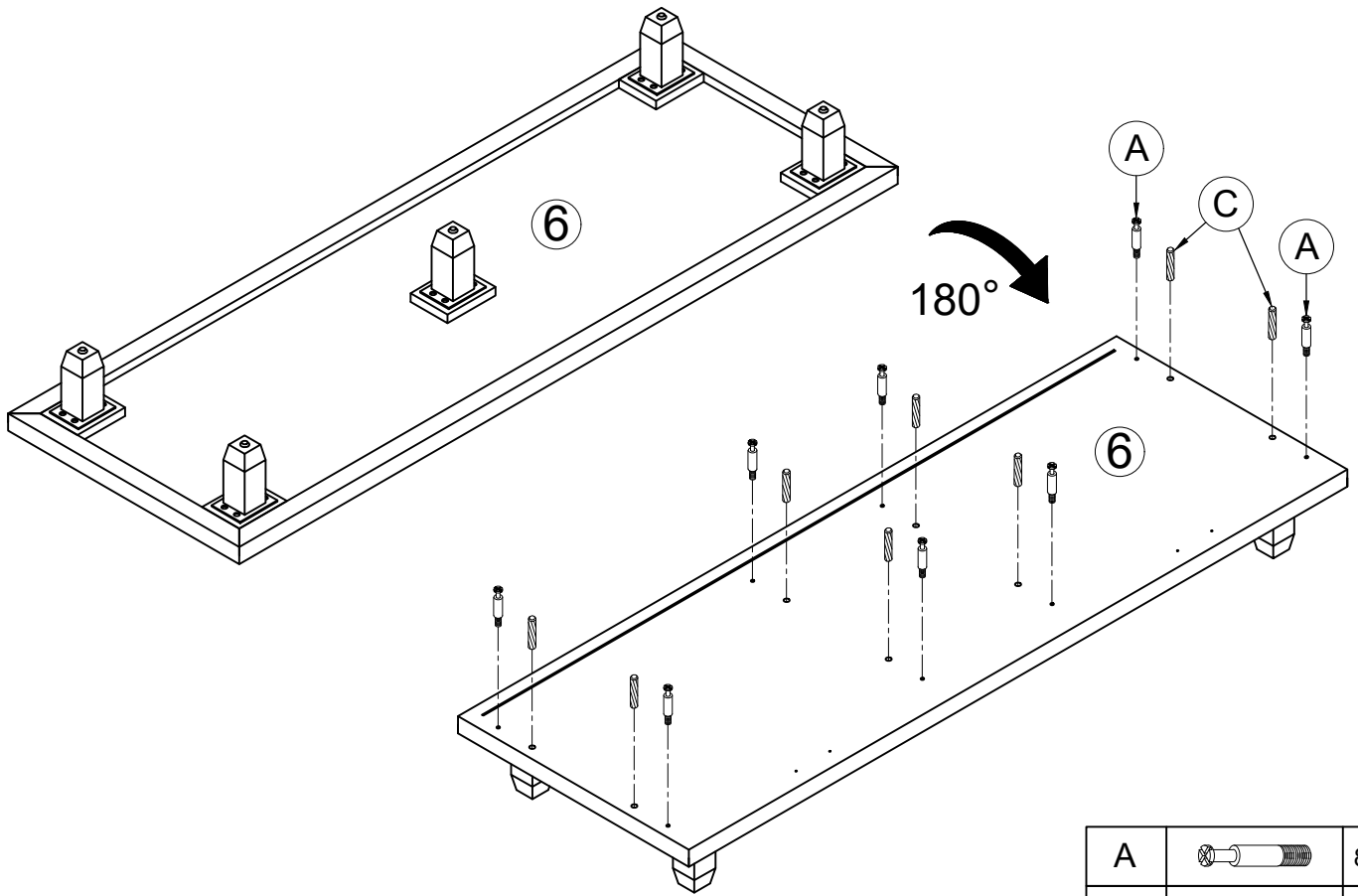

STEP 5

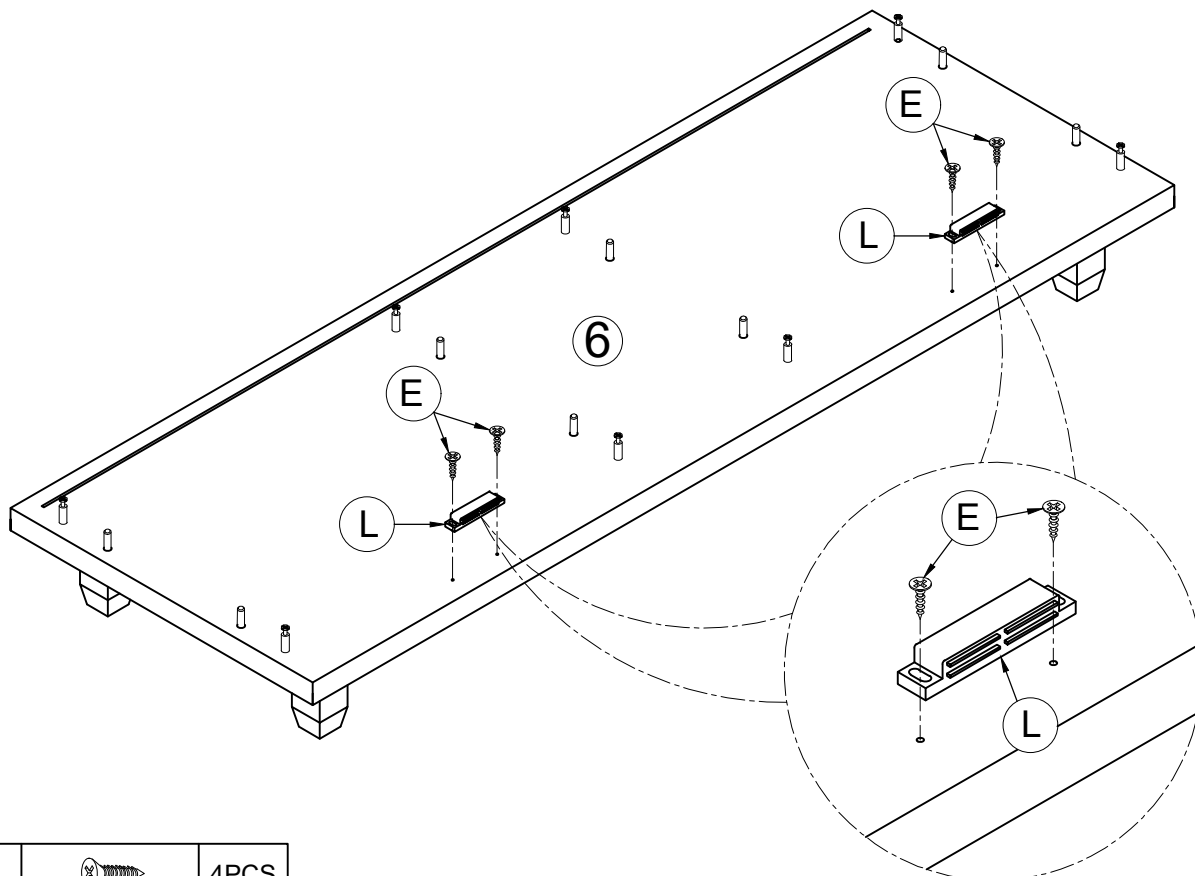

A		8PCS
C		8PCS

STEP 6





E		4PCS
L		2PCS

ASSEMBLY INSTRUCTIONS

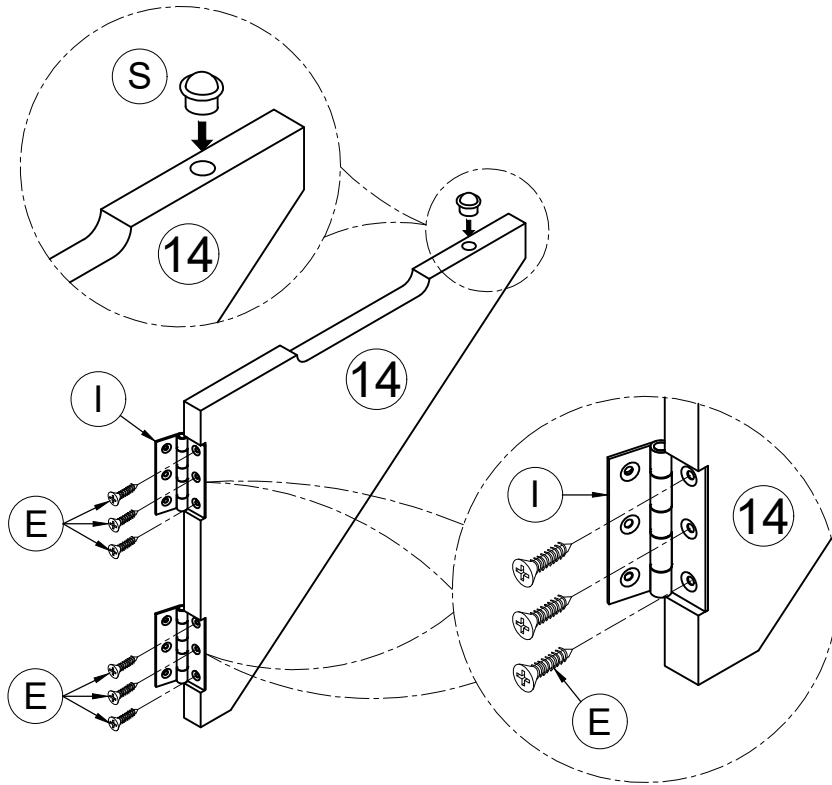
STEP 7



I		2PCS
E		6PCS
S		1PC

STEP 8

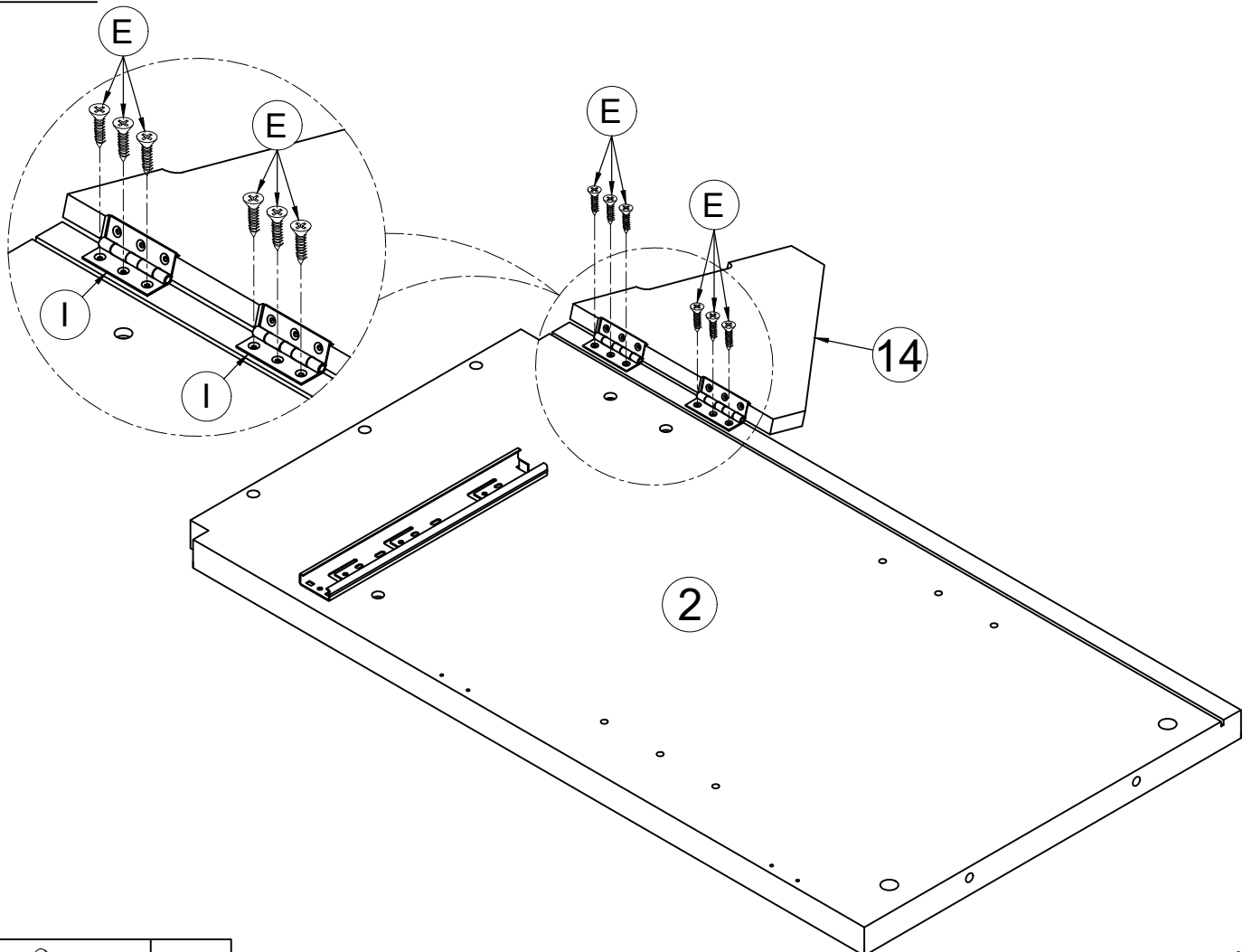



E		6PCS
---	---	------

ASSEMBLY INSTRUCTIONS

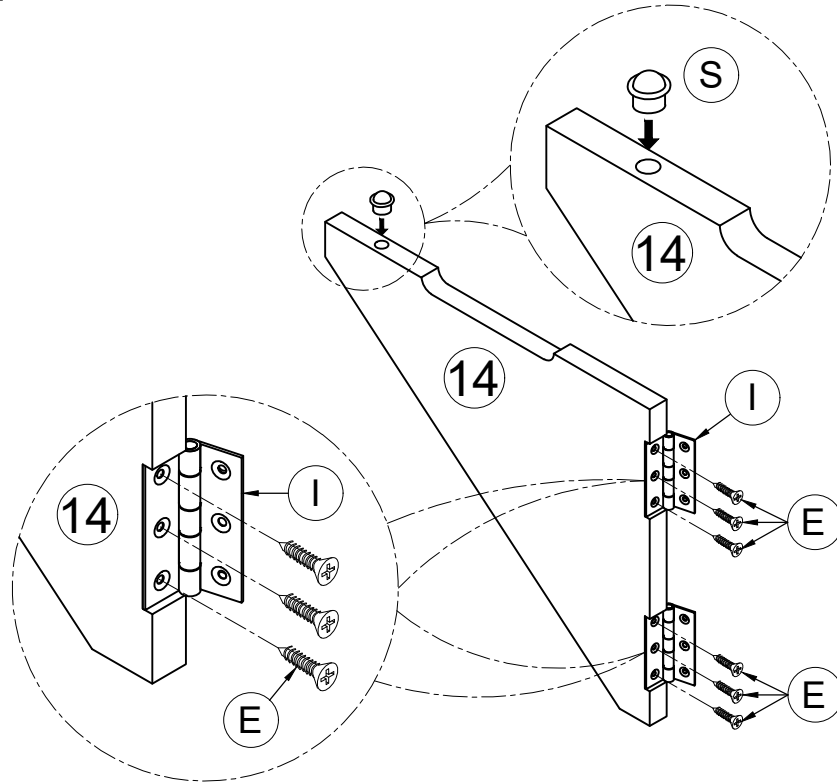
STEP 9



I		2PCS
E		6PCS
S		1PC

STEP 10

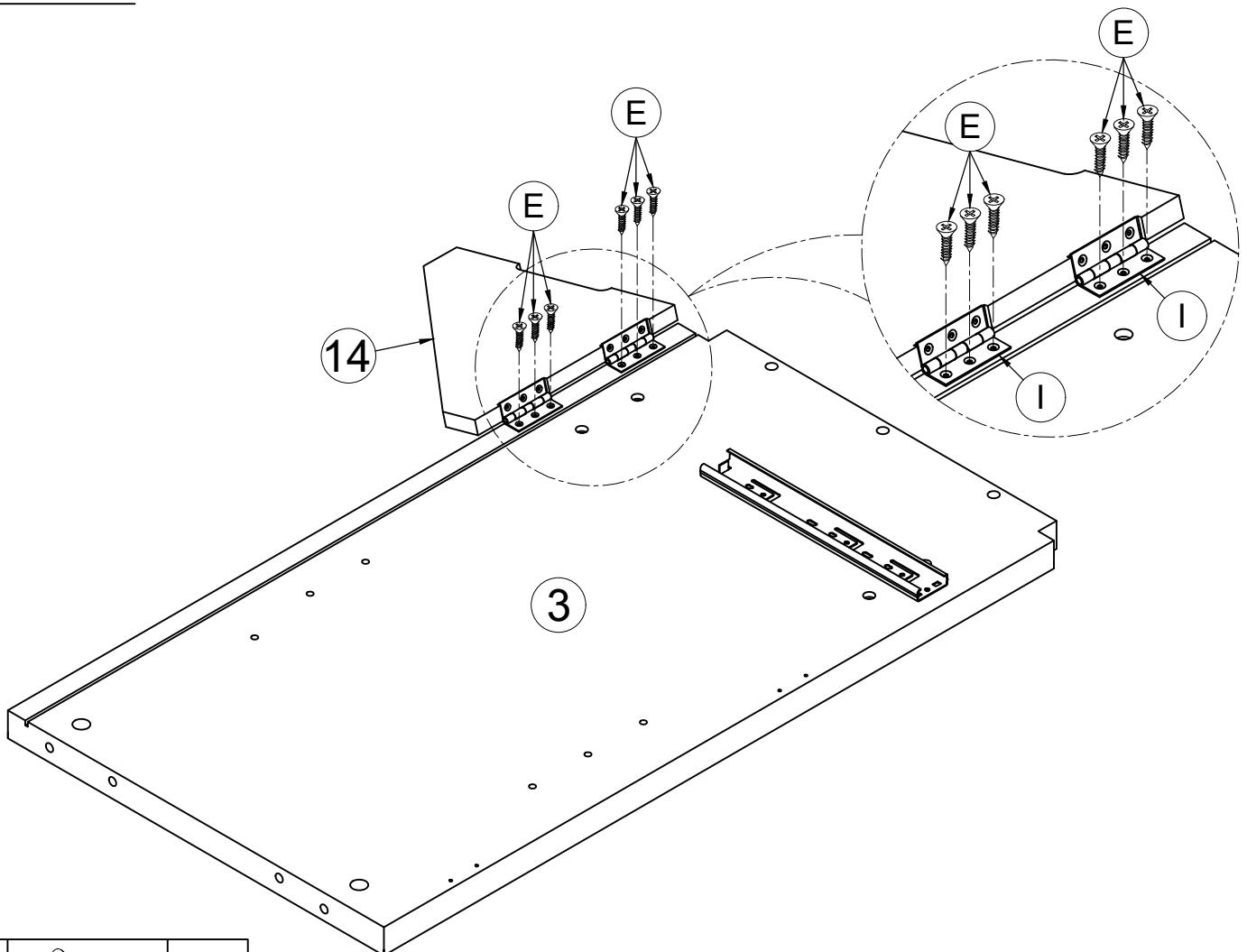

E		6PCS
---	---	------

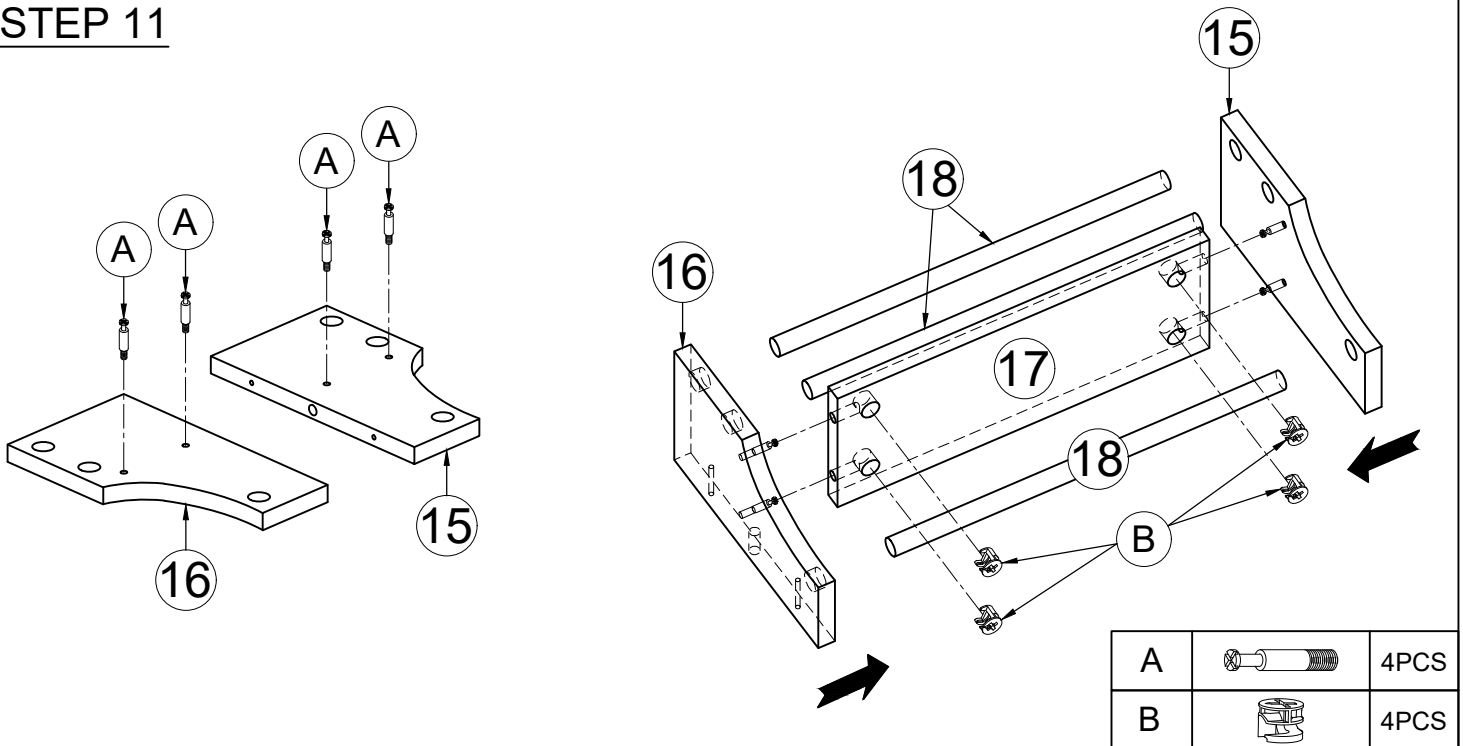

ASSEMBLY INSTRUCTIONS

STEP 11

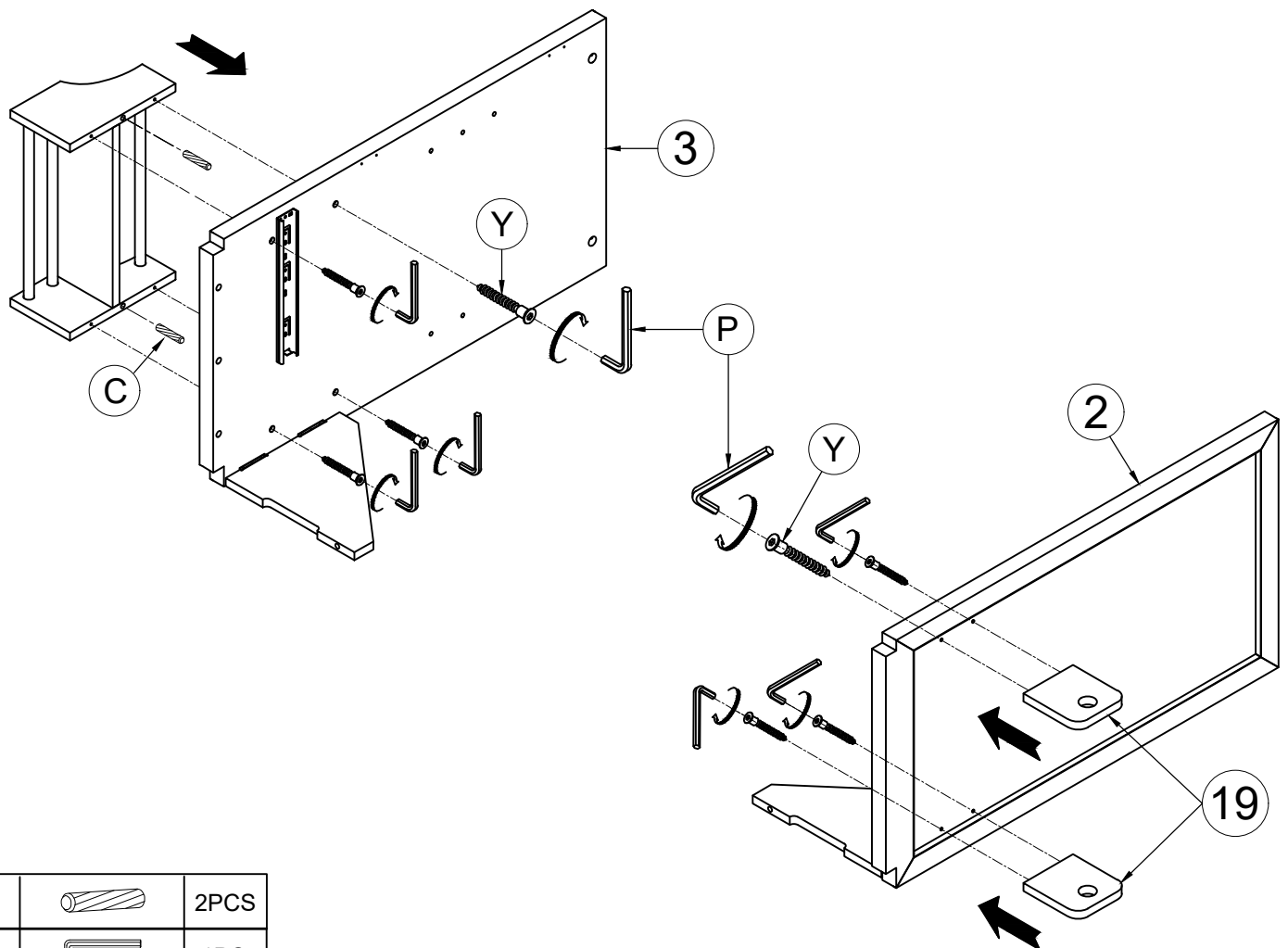

STEP 12

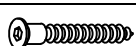

C		2PCS
P		1PC
Y		8PCS

ASSEMBLY INSTRUCTIONS

STEP 13

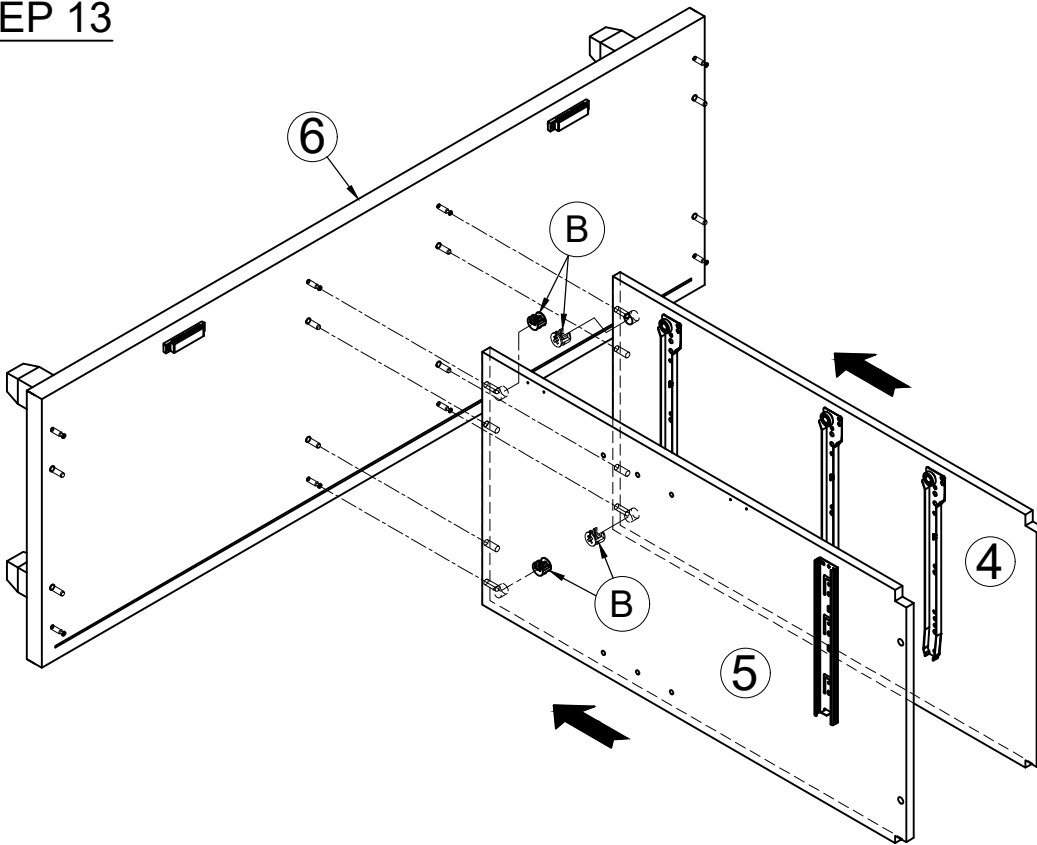

B		4PCS
---	--	------

STEP 14

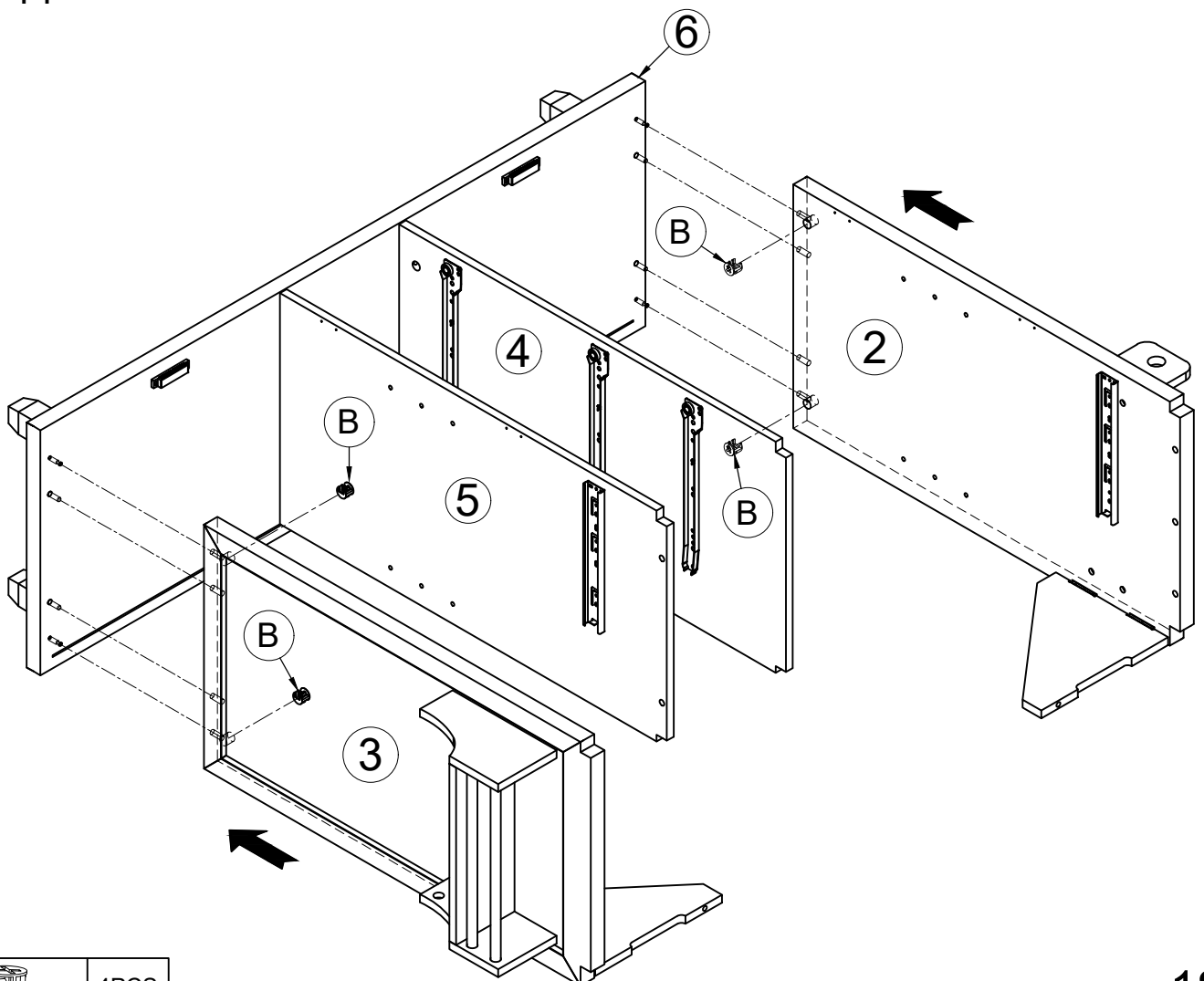

B		4PCS
---	---	------

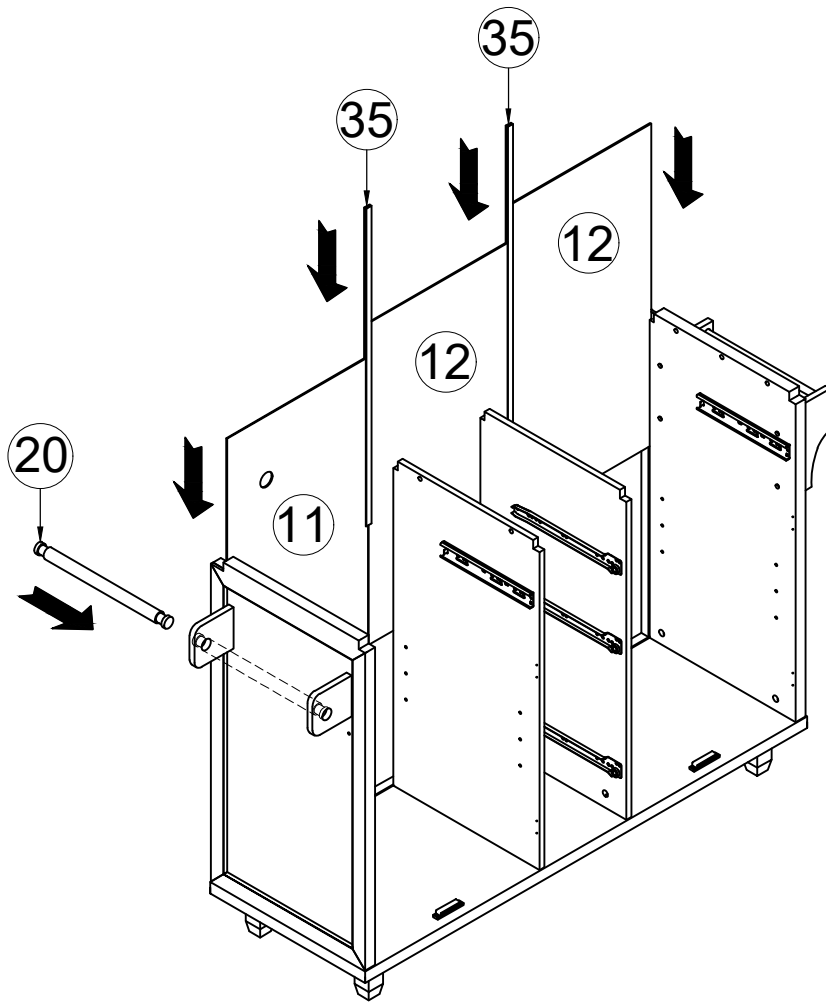

ASSEMBLY INSTRUCTIONS

STEP 15

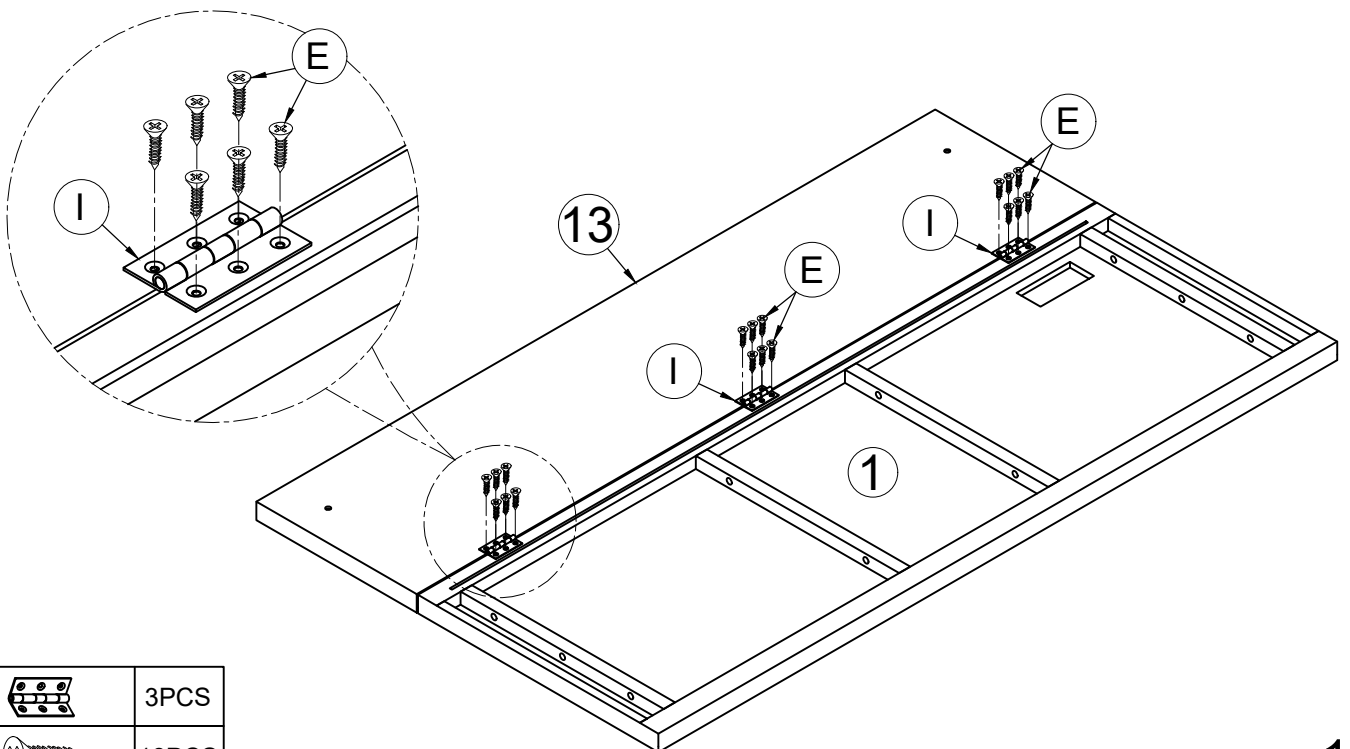

STEP 16





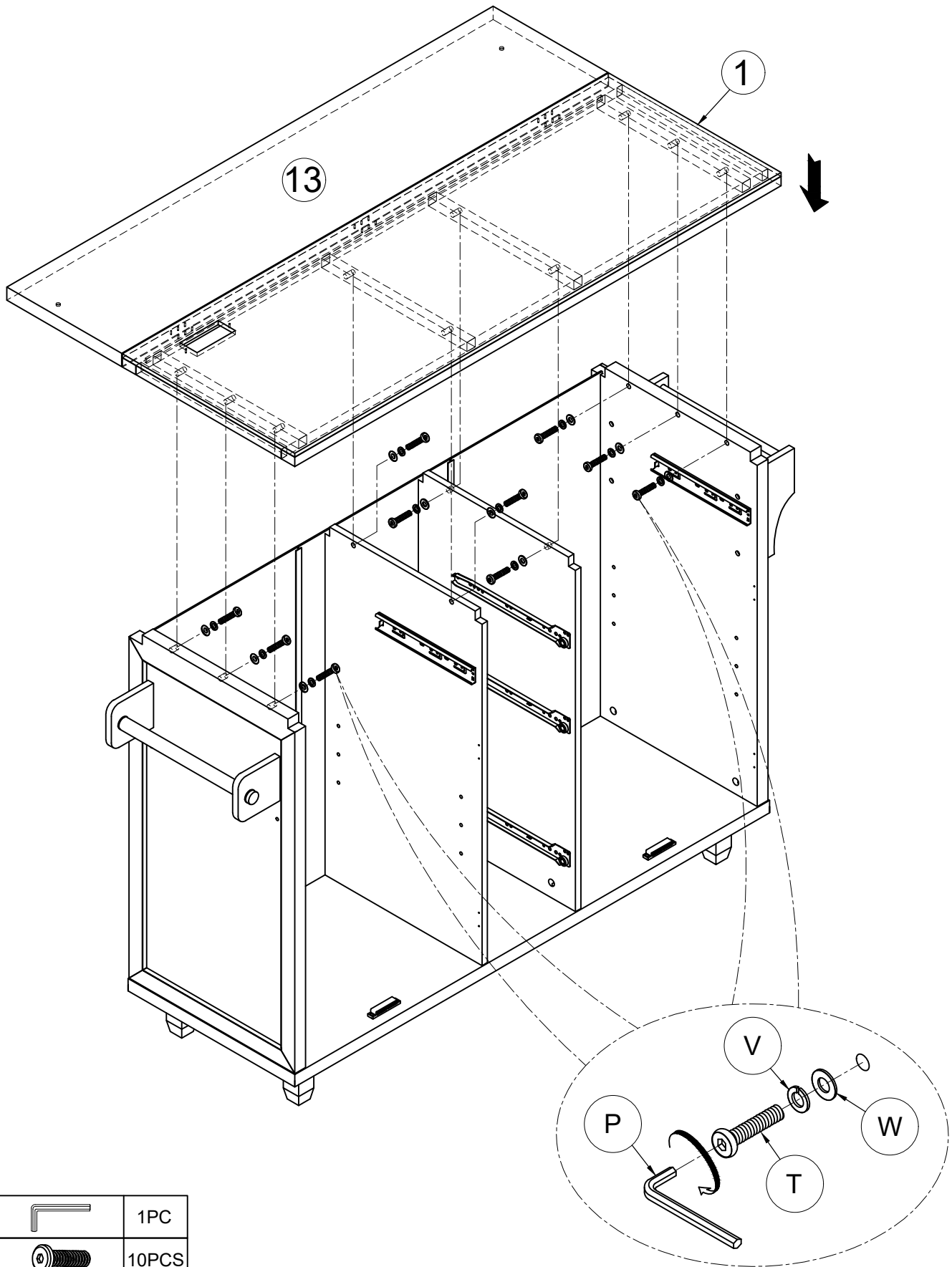

I		3PCS
E		18PCS

ASSEMBLY INSTRUCTIONS

STEP 17



P		1PC
T		10PCS
V		10PCS
W		10PCS

ASSEMBLY INSTRUCTIONS

STEP 18

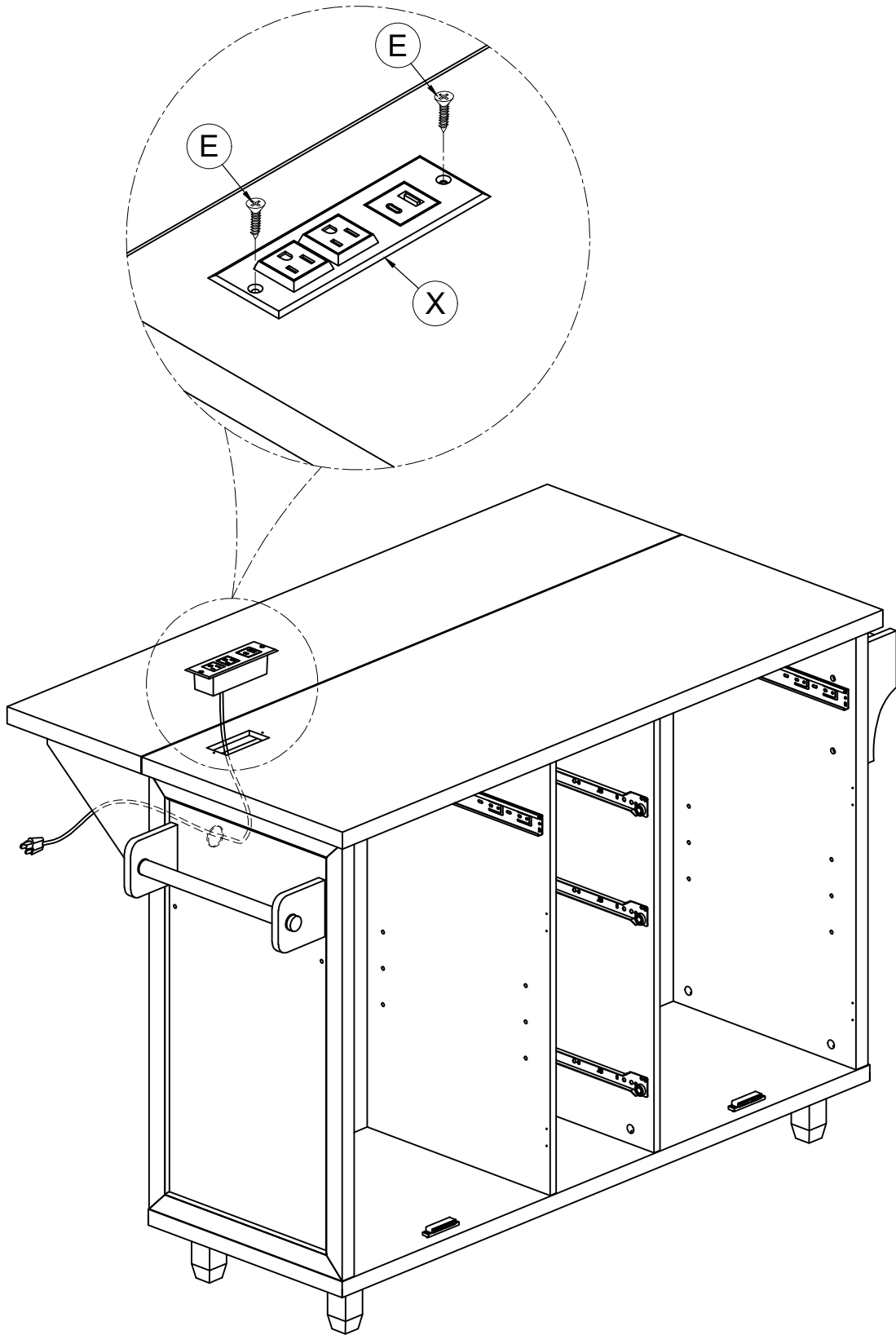

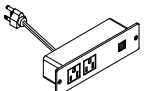
E		2PCS
X		1PC

ASSEMBLY INSTRUCTIONS

STEP 19

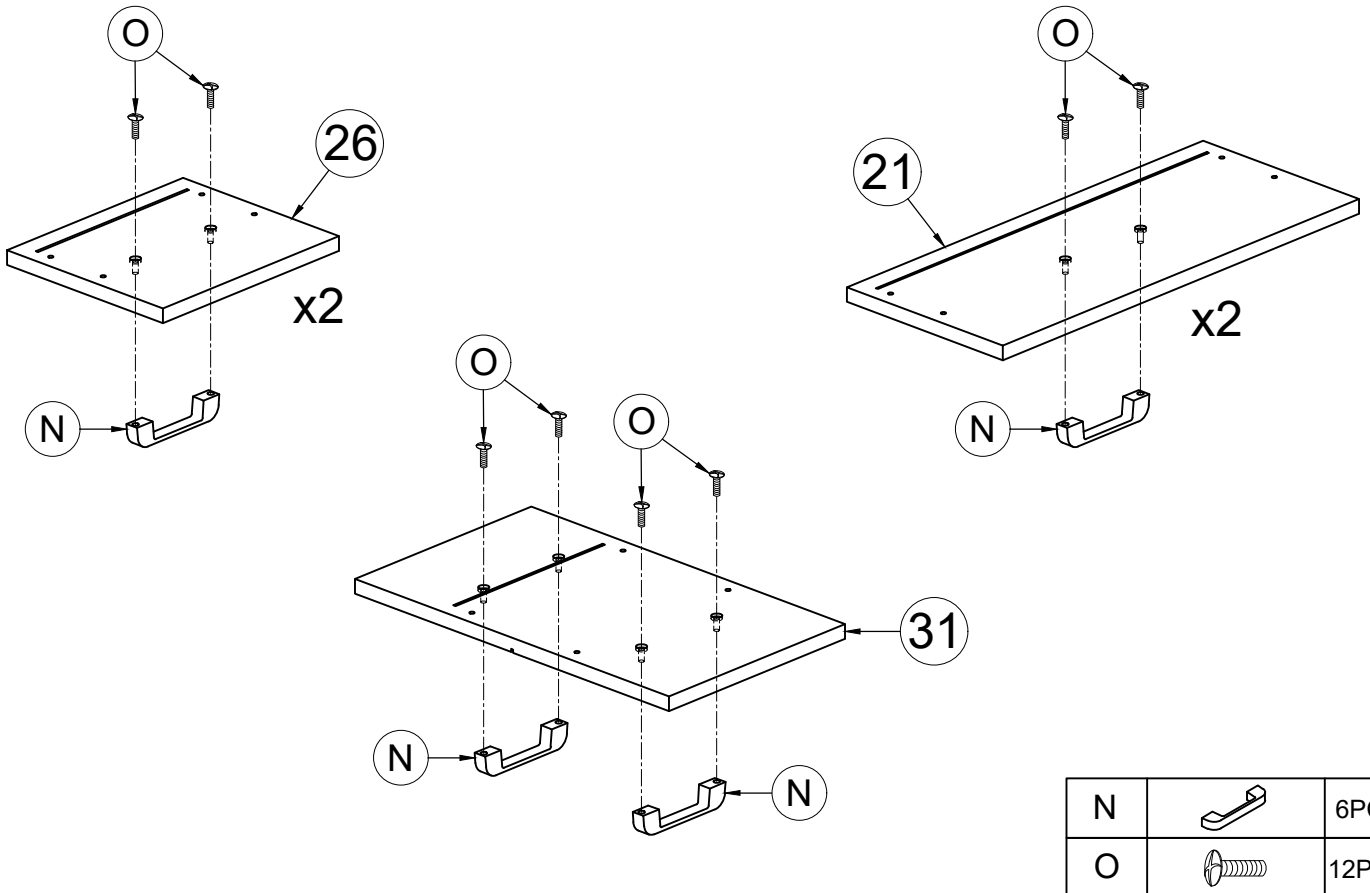

N		6PCS
O		12PCS

STEP 20 x2 SET

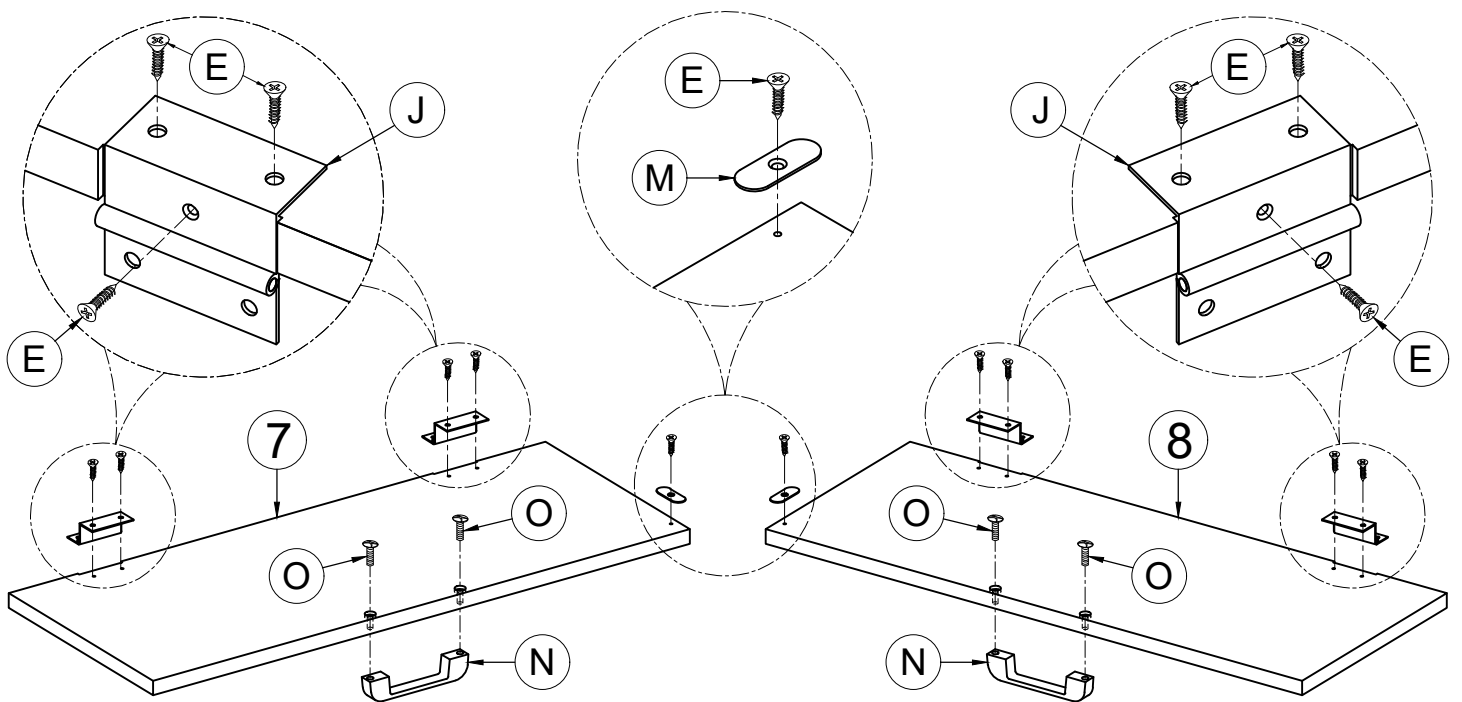



E		28PCS	N		4PCS
J		8PCS	O		8PCS
M		4PCS			

ASSEMBLY INSTRUCTIONS

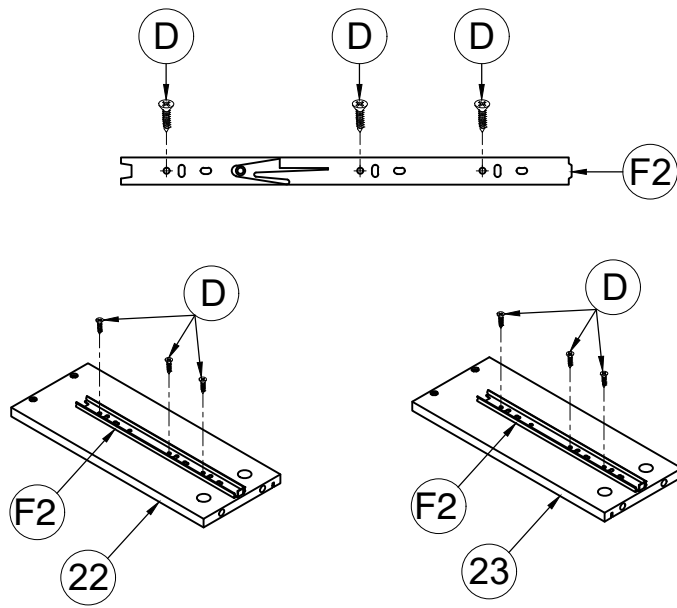

STEP 21 x2 Set

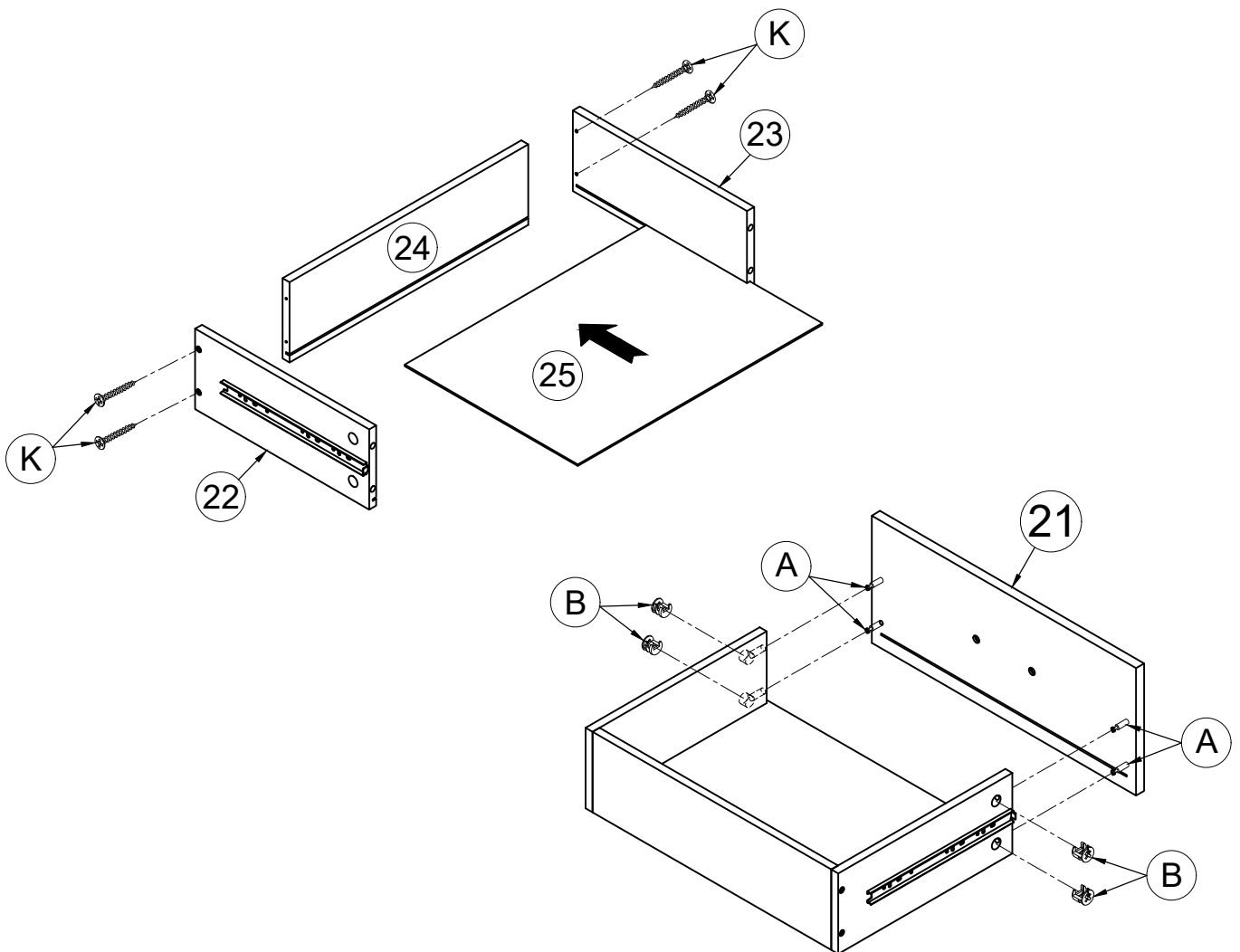

D		12PCS
F2		4PCS

STEP 22 x2 Set

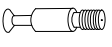

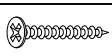

A		8PCS			
B		8PCS	K		8PC

ASSEMBLY INSTRUCTIONS

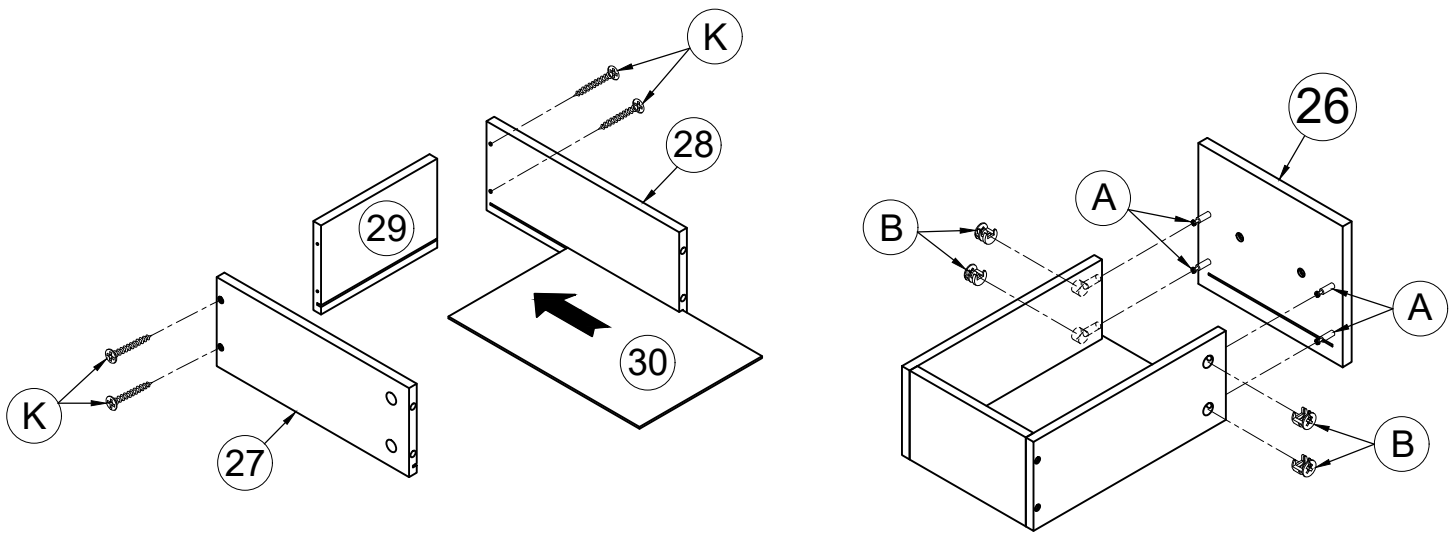

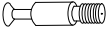
STEP 23 x2 Set

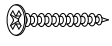

A		8PCS			
B		8PCS	K		8PC

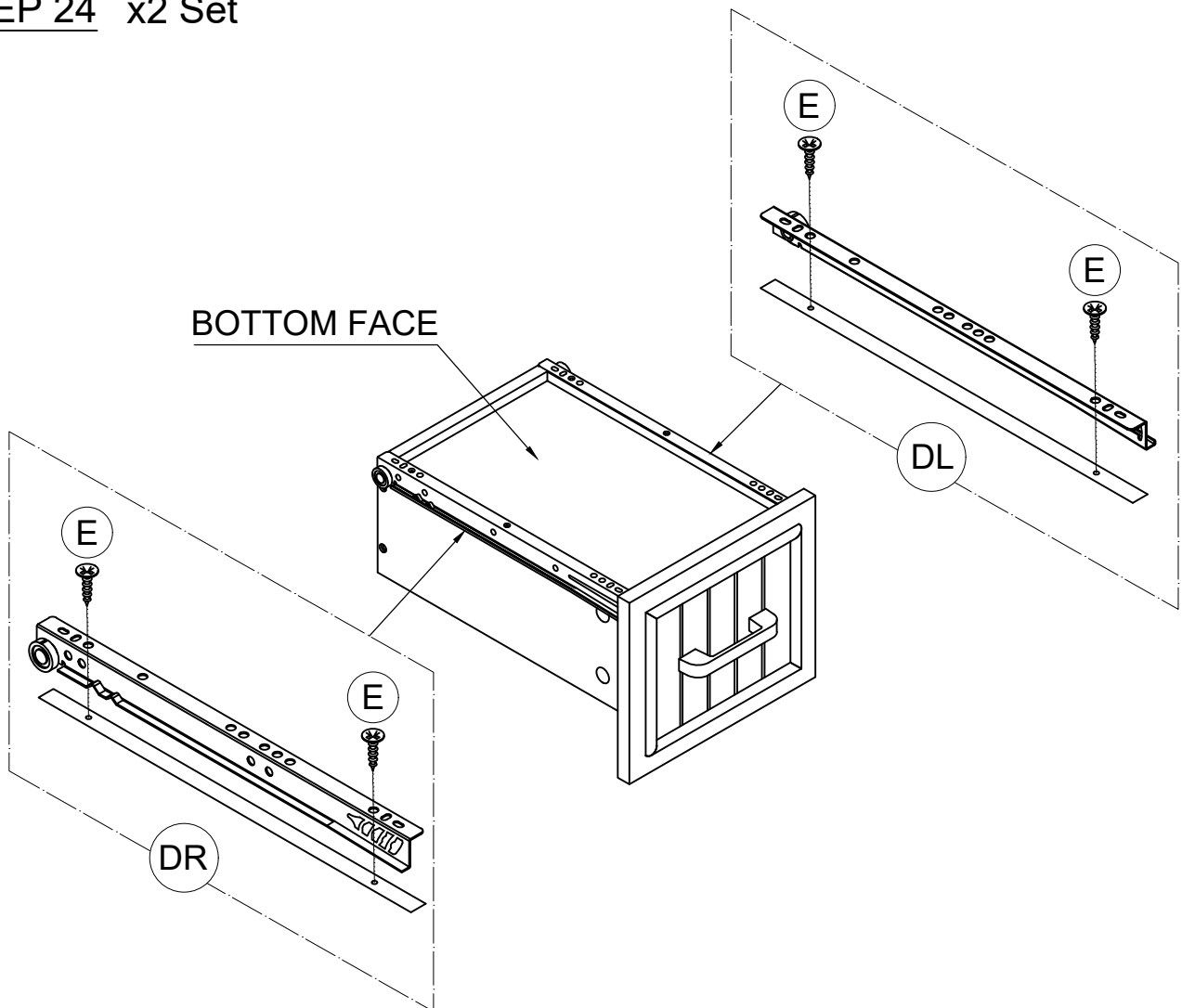
STEP 24 x2 Set





E		8PCS	DL		2PCS	DR		2PCS
---	---	------	----	---	------	----	---	------

ASSEMBLY INSTRUCTIONS

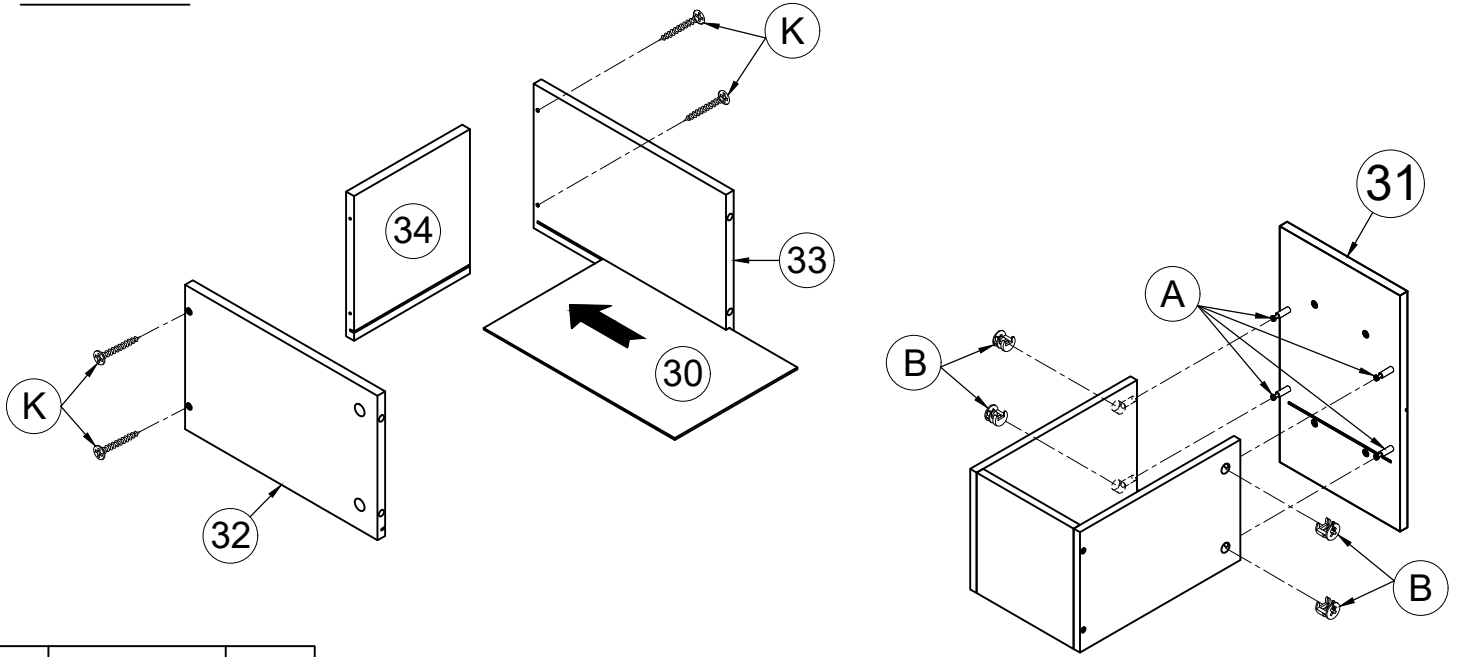

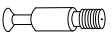
STEP 25

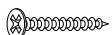

A		4PCS			
B		4PCS	K		4PC

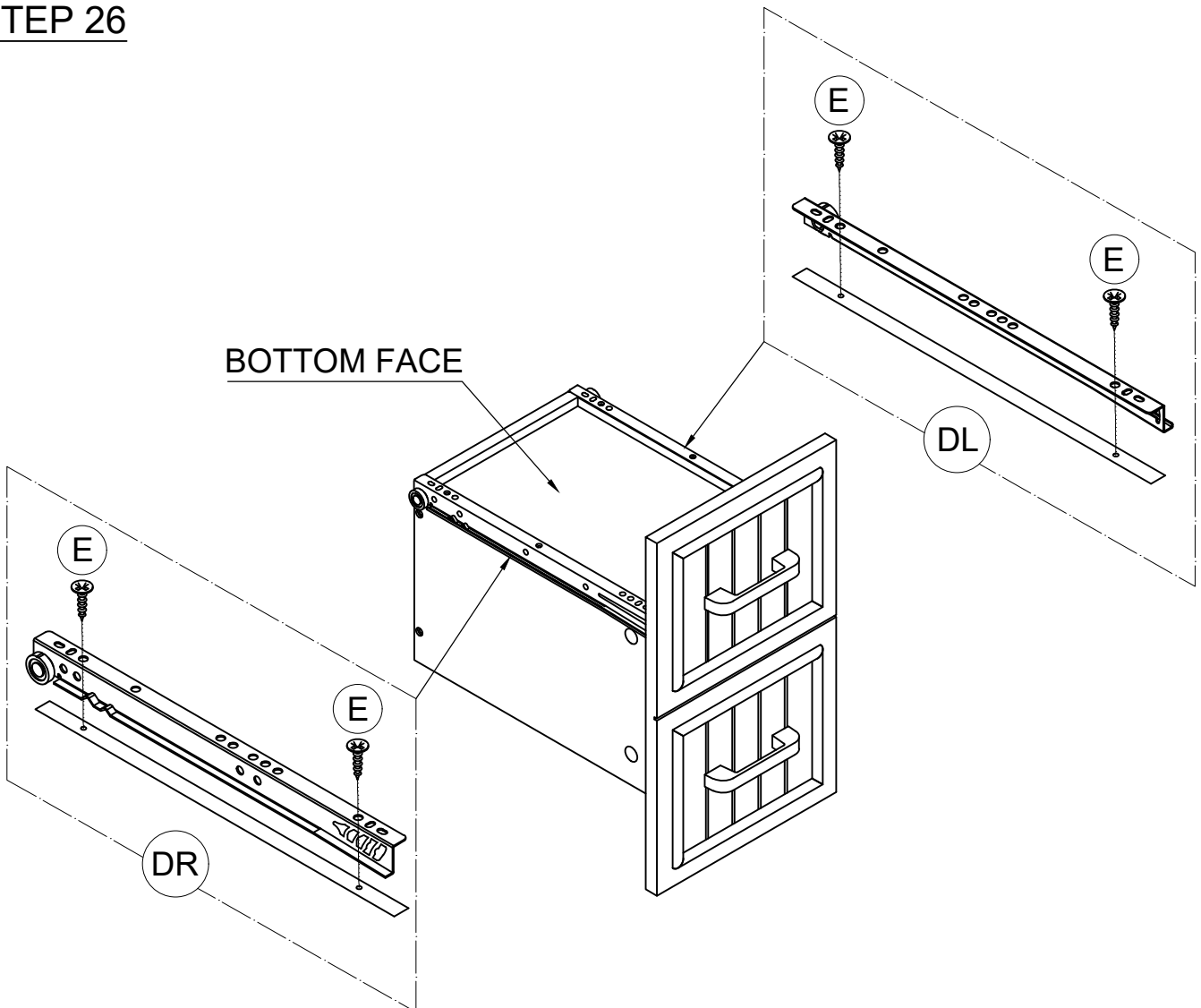
STEP 26



E		4PCS	DL		1PC	DR		1PC
---	---	------	----	---	-----	----	---	-----

ASSEMBLY INSTRUCTIONS

STEP 27

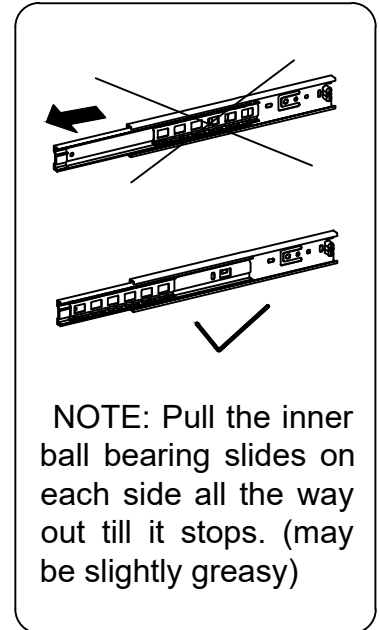
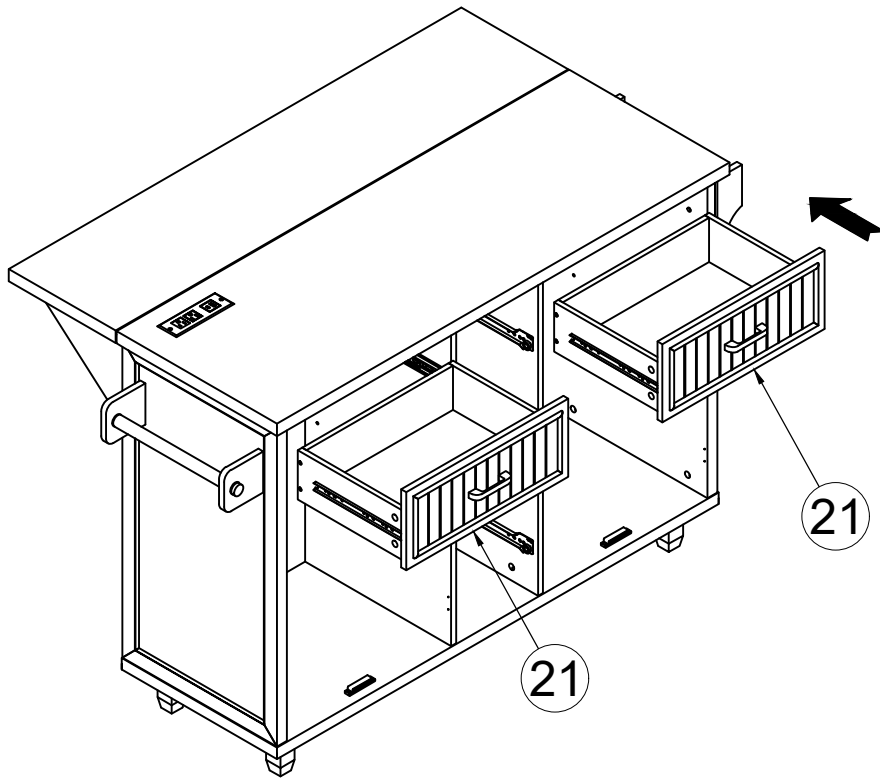

NOTE: Pull the inner ball bearing slides on each side all the way out till it stops. (may be slightly greasy)

STEP 28

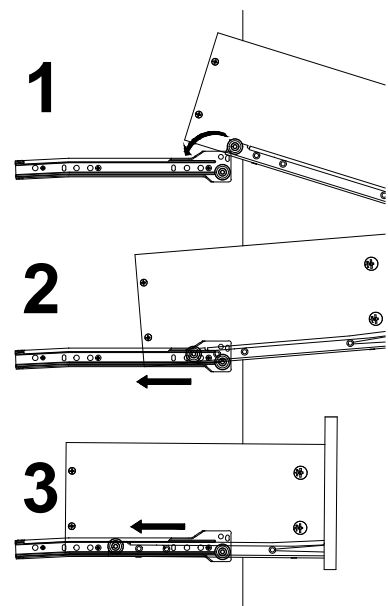
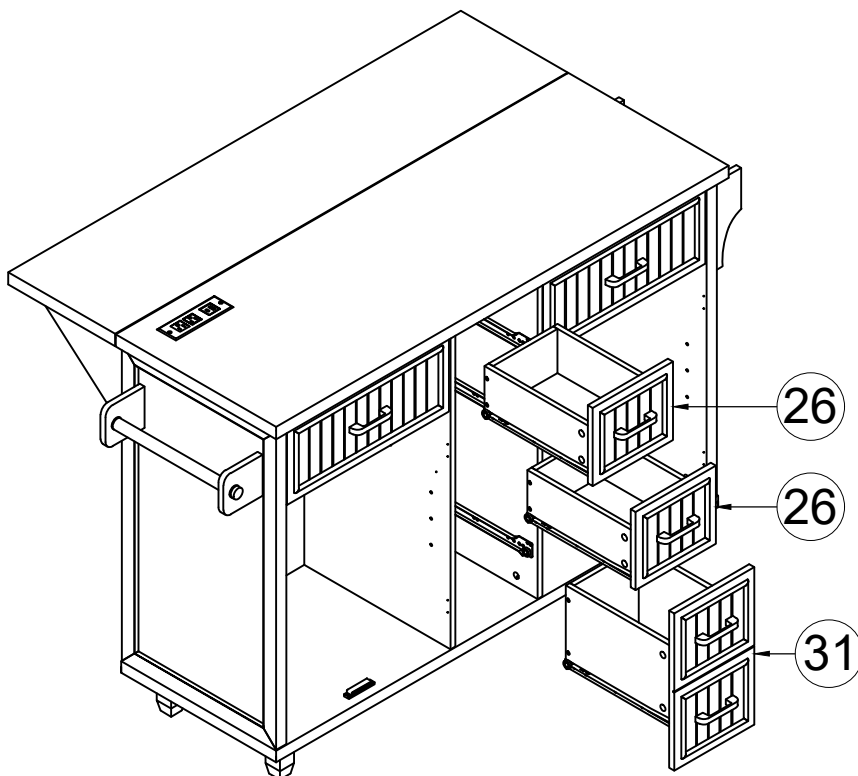

ASSEMBLY INSTRUCTIONS

STEP 29

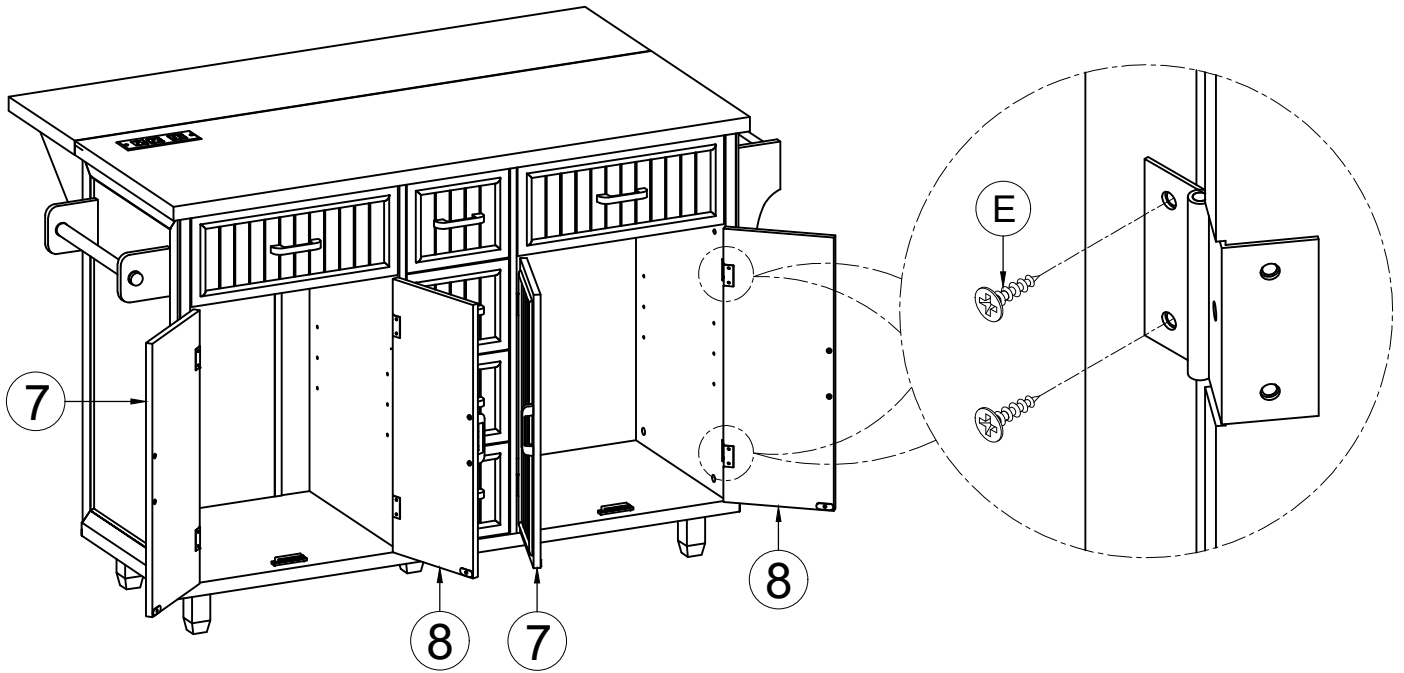

E		16PCS
---	---	-------

STEP 30

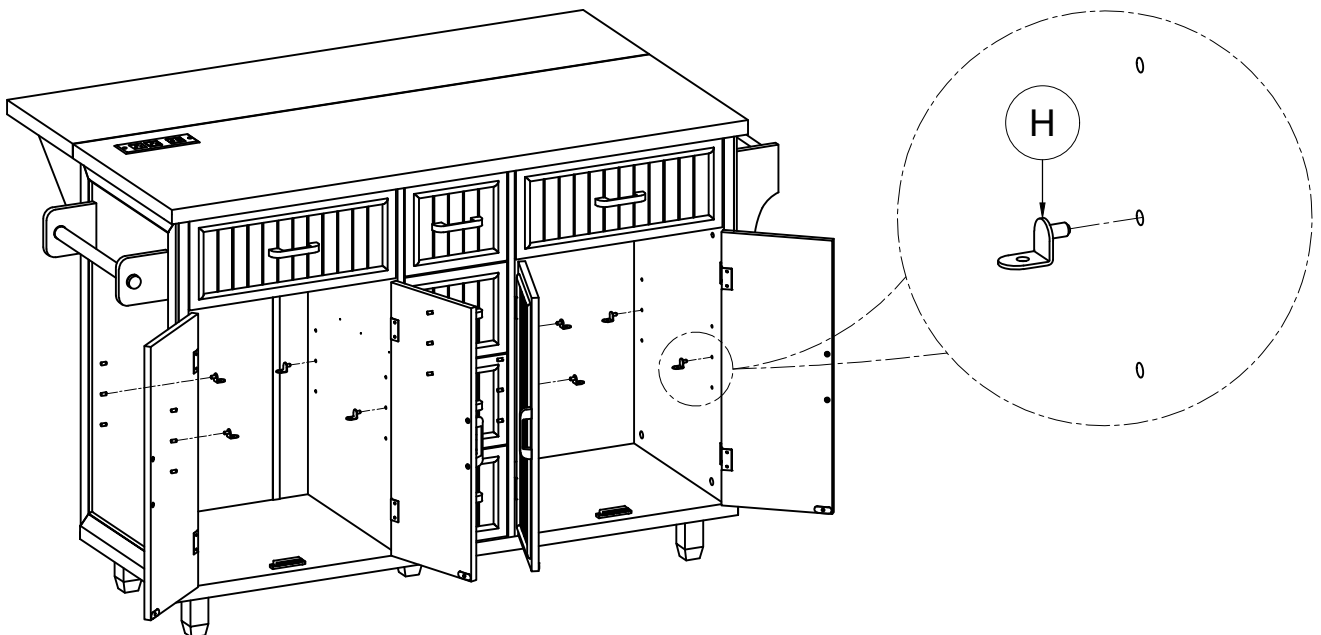

H		8PCS
---	---	------

ASSEMBLY INSTRUCTIONS

STEP 31

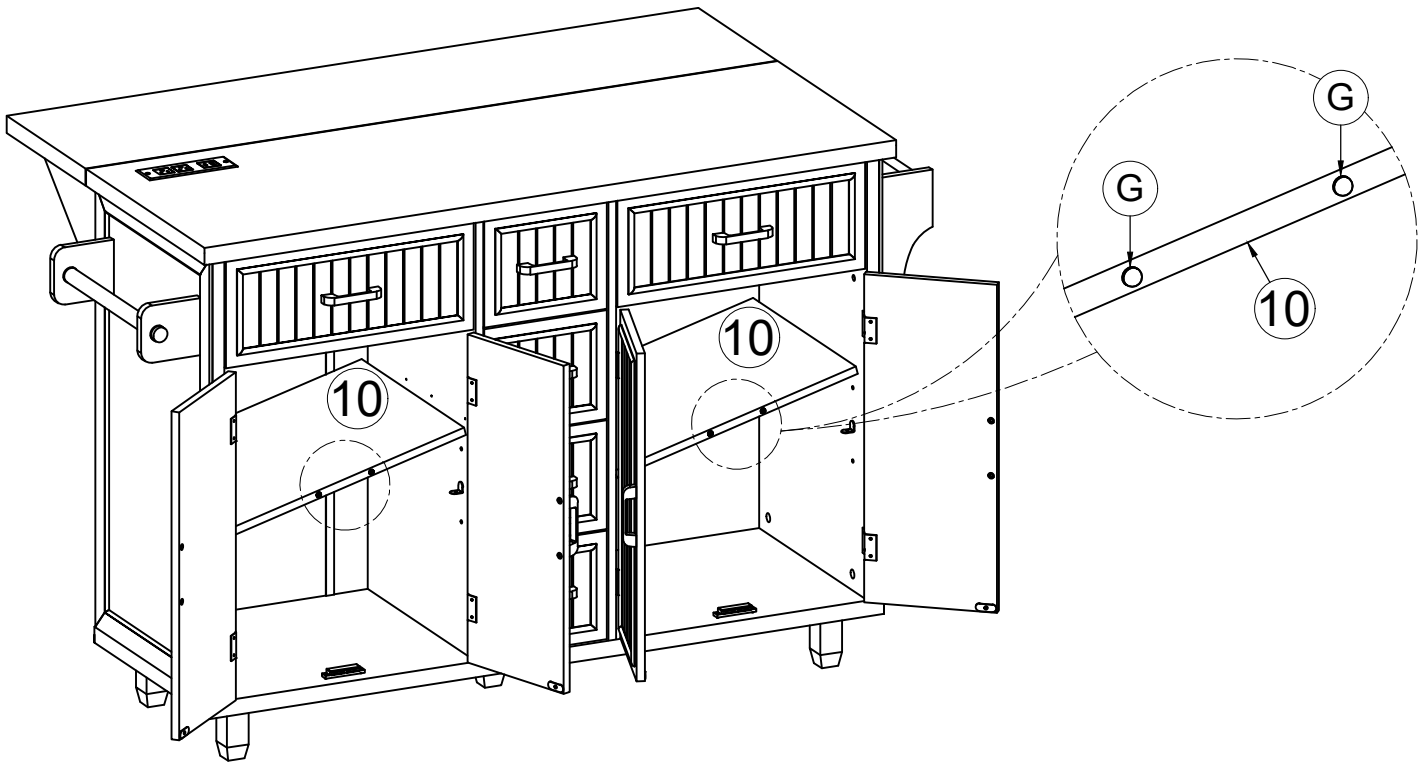

G		4PCS
---	---	------

COMPLETED !

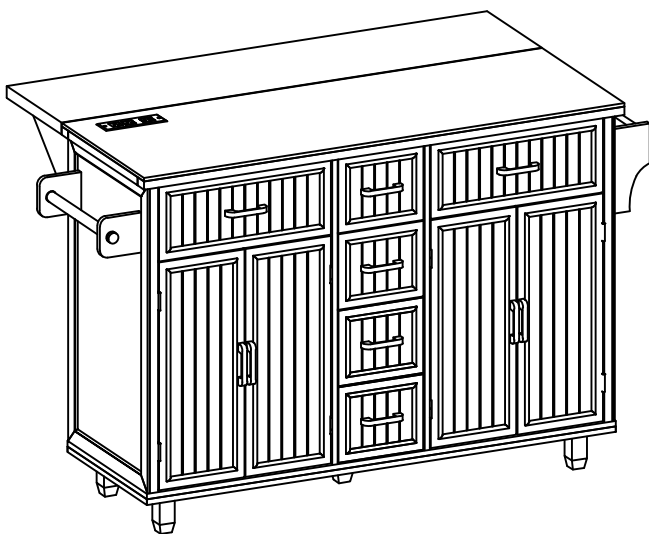

OPTION WITH THE FEET

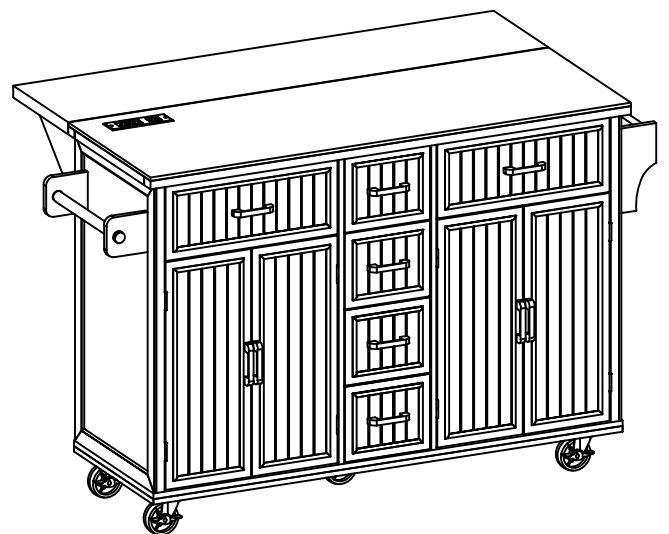

OPTION WITH THE WHEELS