

IT IS RECOMMENDED
TO USE POWER TOOLS

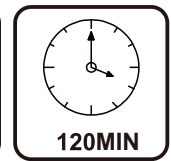

120MIN

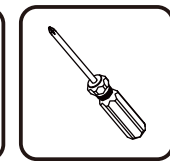
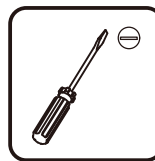

EN_IMPORTANT, RETAIN FOR FUTURE REFERENCE: READ CAREFULLY.

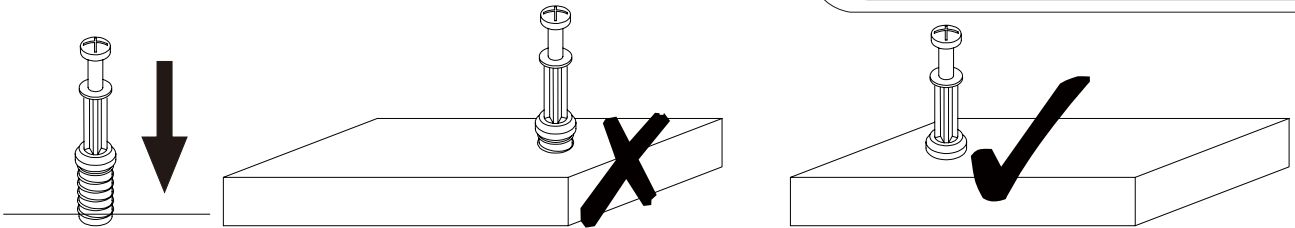

EN_QUICKFIT: Tighten quickfit until shoulder is flush with panel. Do not overtighten or undertighten.

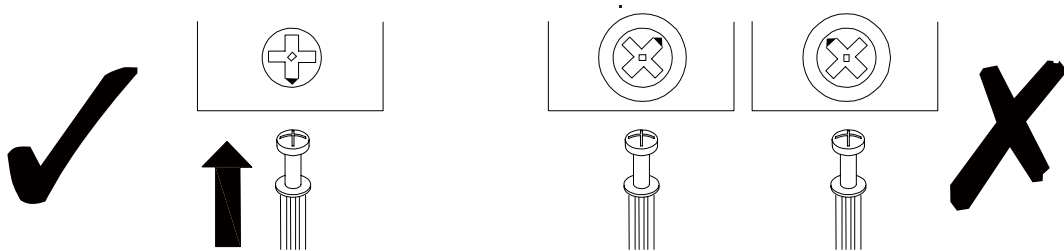

EN_CAM LOCK: When fitting cam lock, ensure starting position is correct before you insert connecting quickfit.

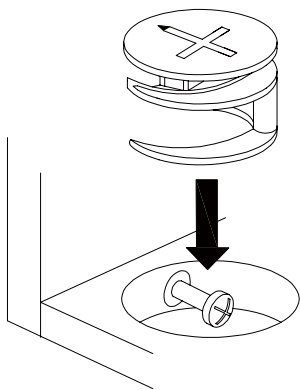

EN_Quickfit head should be in the centre of the cam lock when the two panels are joined.
Cam lock should be inserted before quickfit.

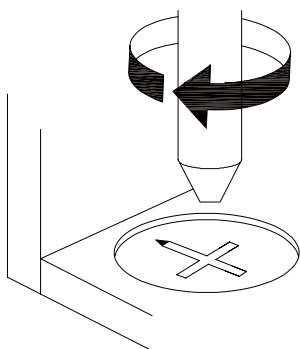



EN_Turn cam lock clockwise to tighten.

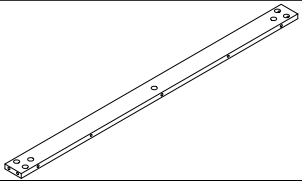
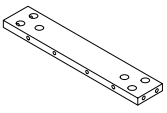
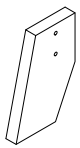
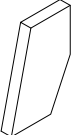
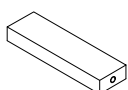
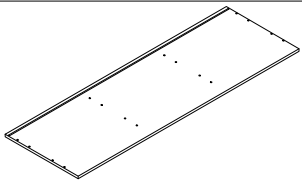
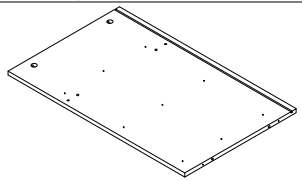
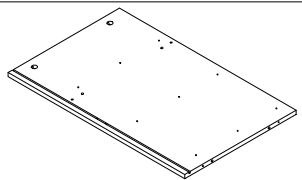
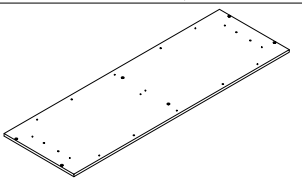
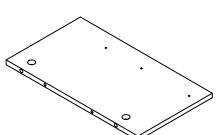

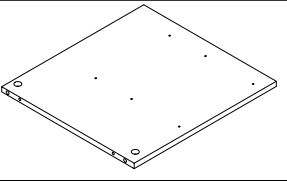
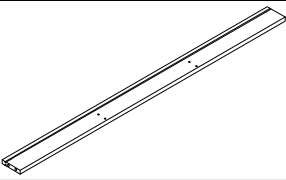
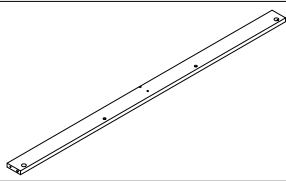
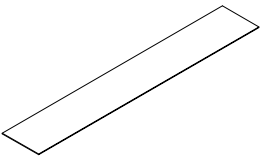
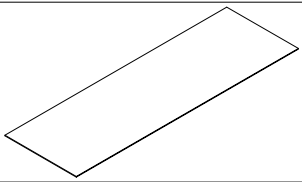
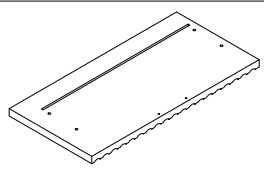
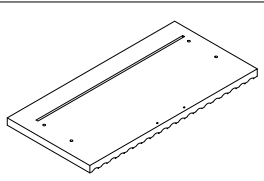
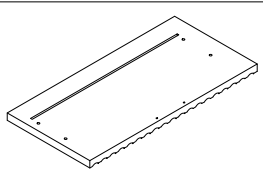
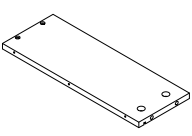
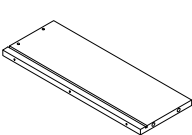

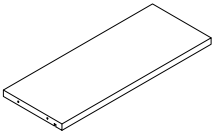
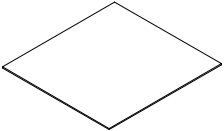
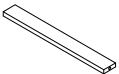
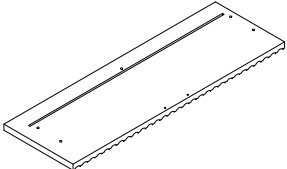
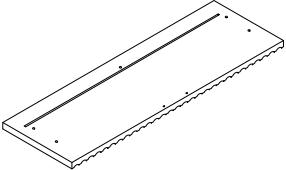
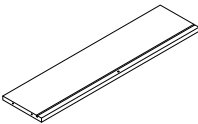
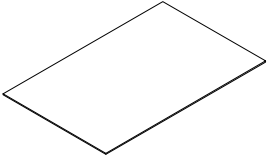



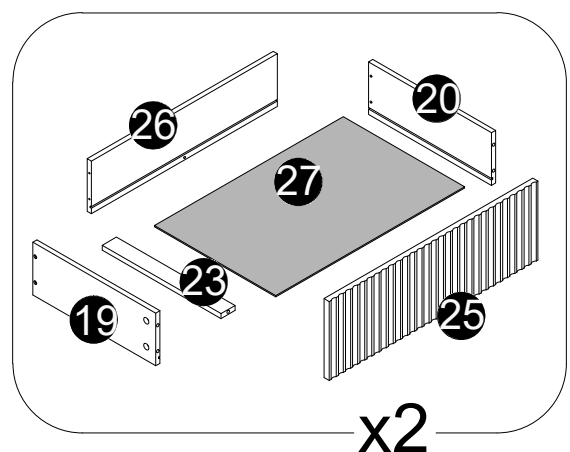
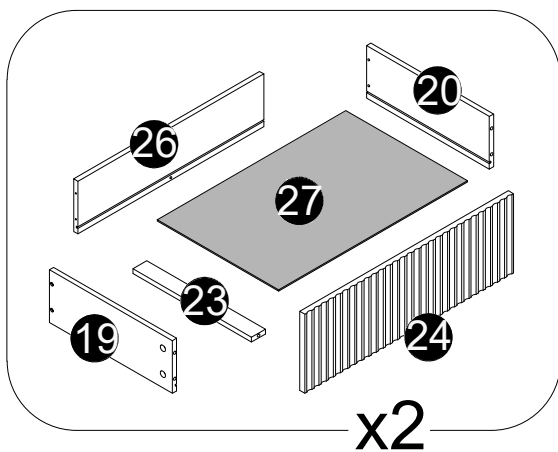
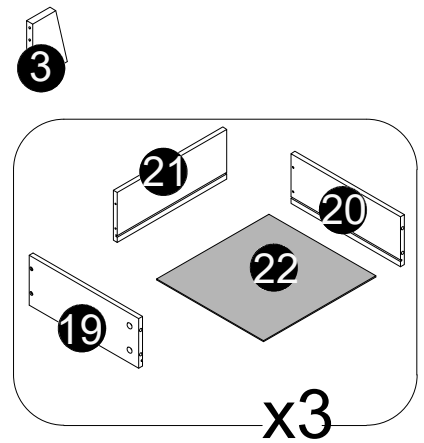
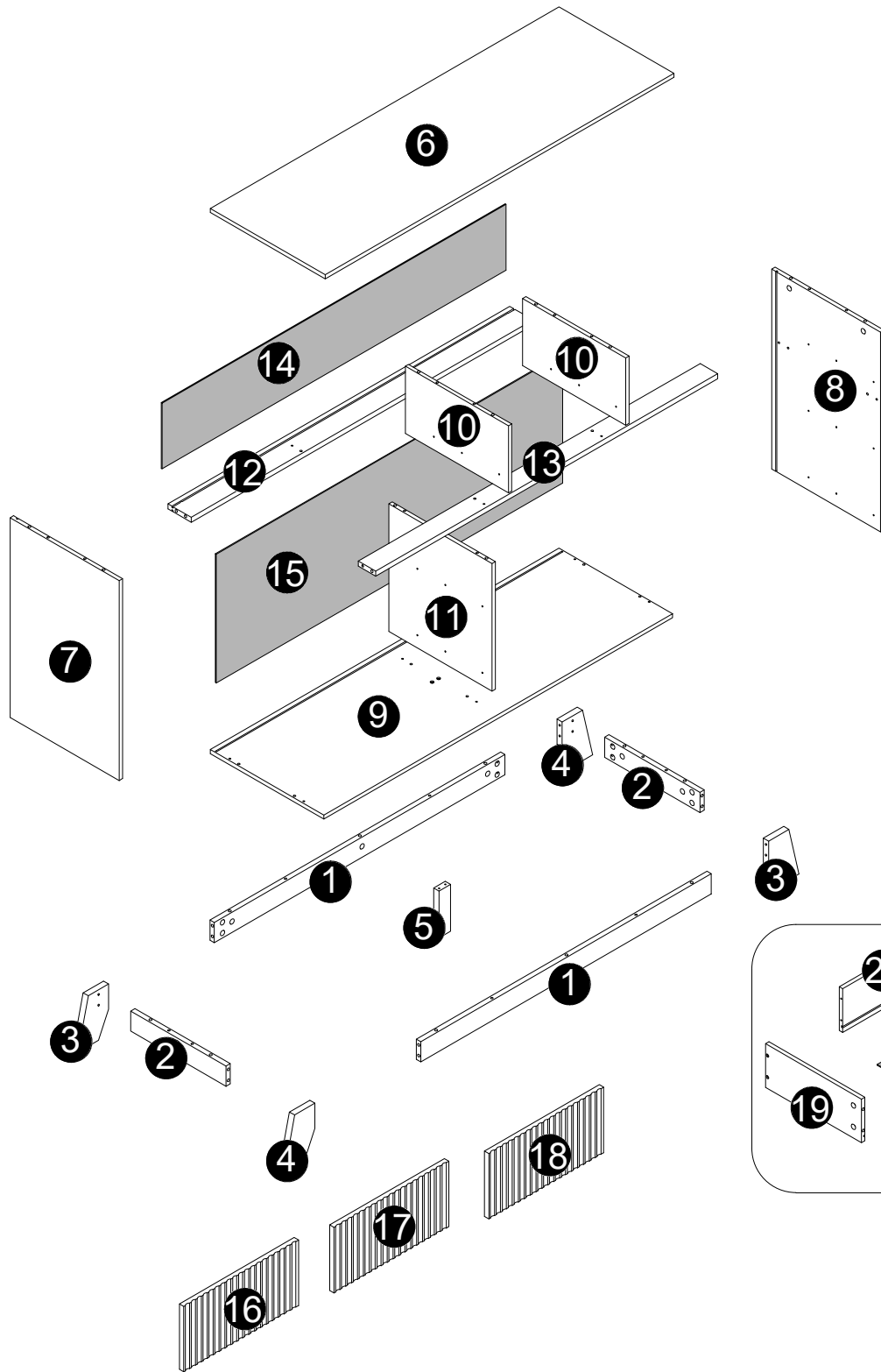

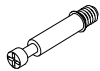
PACKING DELALS

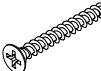

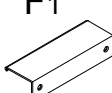
NO.	PARTS	QTY	SPARE
①		x2	
②		x2	
③		x2	
④		x2	
⑤		x1	
⑥		x1	
⑦		x1	
⑧		x1	
⑨		x1	
⑩		x2	

NO.	PARTS	QTY	SPARE
⑪		x1	
⑫		x1	
⑬		x1	
⑭		x1	
⑮		x1	
⑯		x1	
⑰		x1	
⑱		x1	
⑲		x7	
⑳		x7	

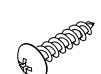
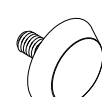
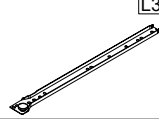
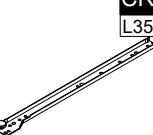
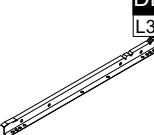
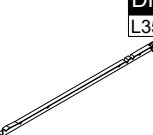
NO.	PARTS	QTY	SPARE
21		x3	
22		x3	
23		x4	
24		x2	
25		x2	
26		x4	
27		x4	
	 Hardware Kit		



 A x74 Ø6x35mm +2(spare)	 B x74 Ø15x10mm +2(spare)	 C x30 Ø6x30mm +3(spare)	 D x46 Ø4x35mm +2(spare)	 E x84 Ø3.5x12mm +3(spare)	 F1	 F2 x7 Ø3.5x10mm
 G x2	 H1 H2 Ø3x16mm +1(spare)	 I x2 Ø6x30mm	 J x2 Ø4x14mm	 K x1	 CL x7 L350mm	
 CR x7 L350mm	 DL x7 L350mm	 DR x7 L350mm	 M x4			

 A x20	 B x20	 D x20
---	---	---

x4 **01**

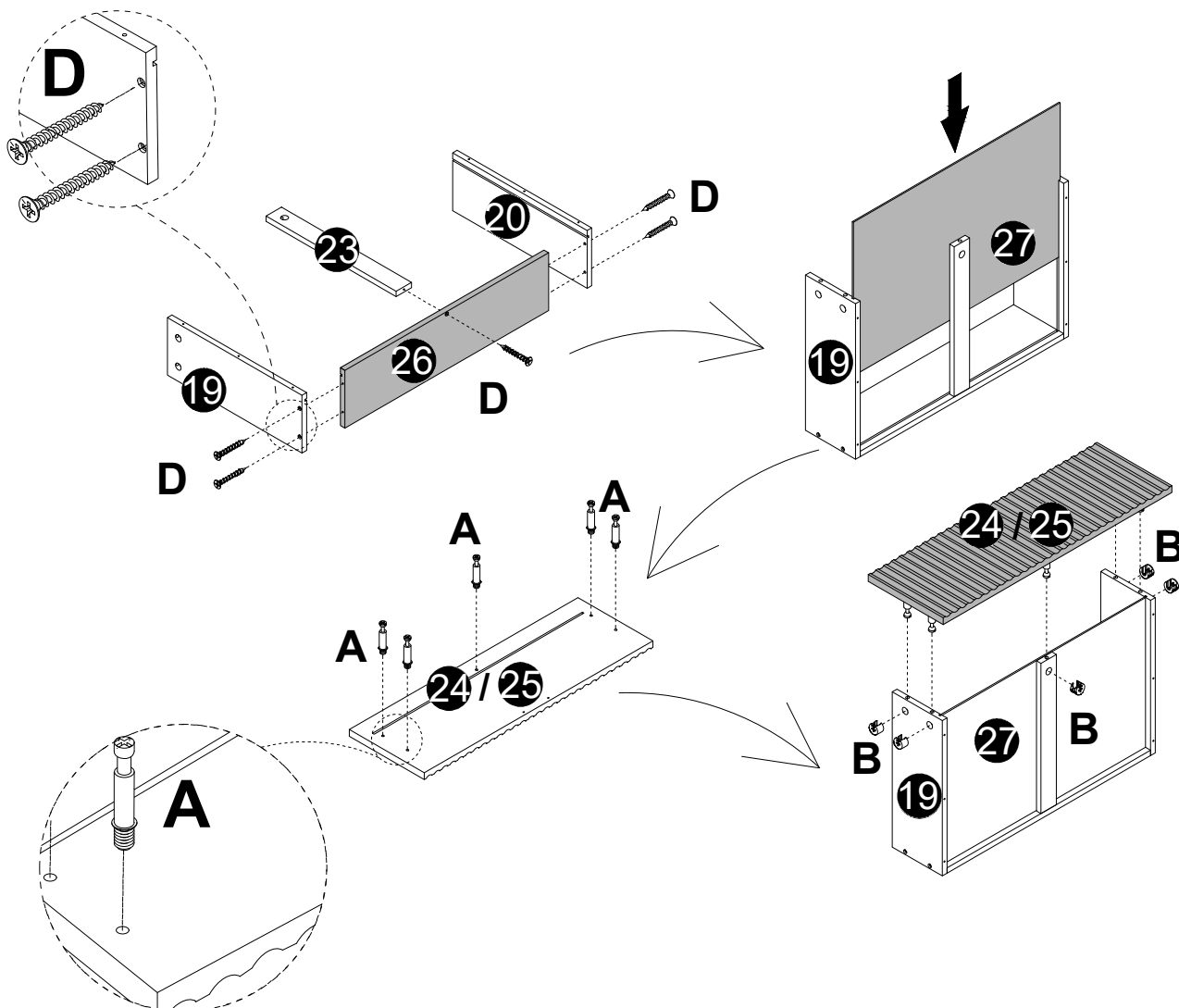

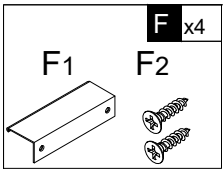

x4 02

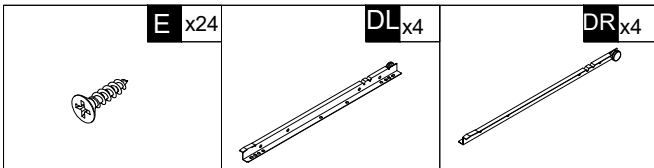
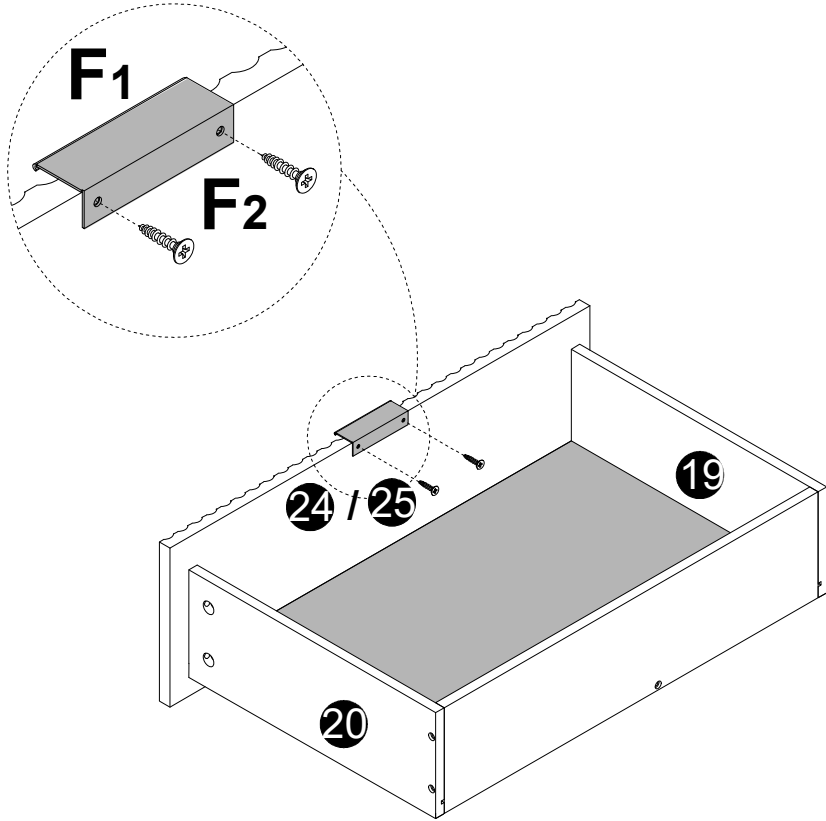

x4 03

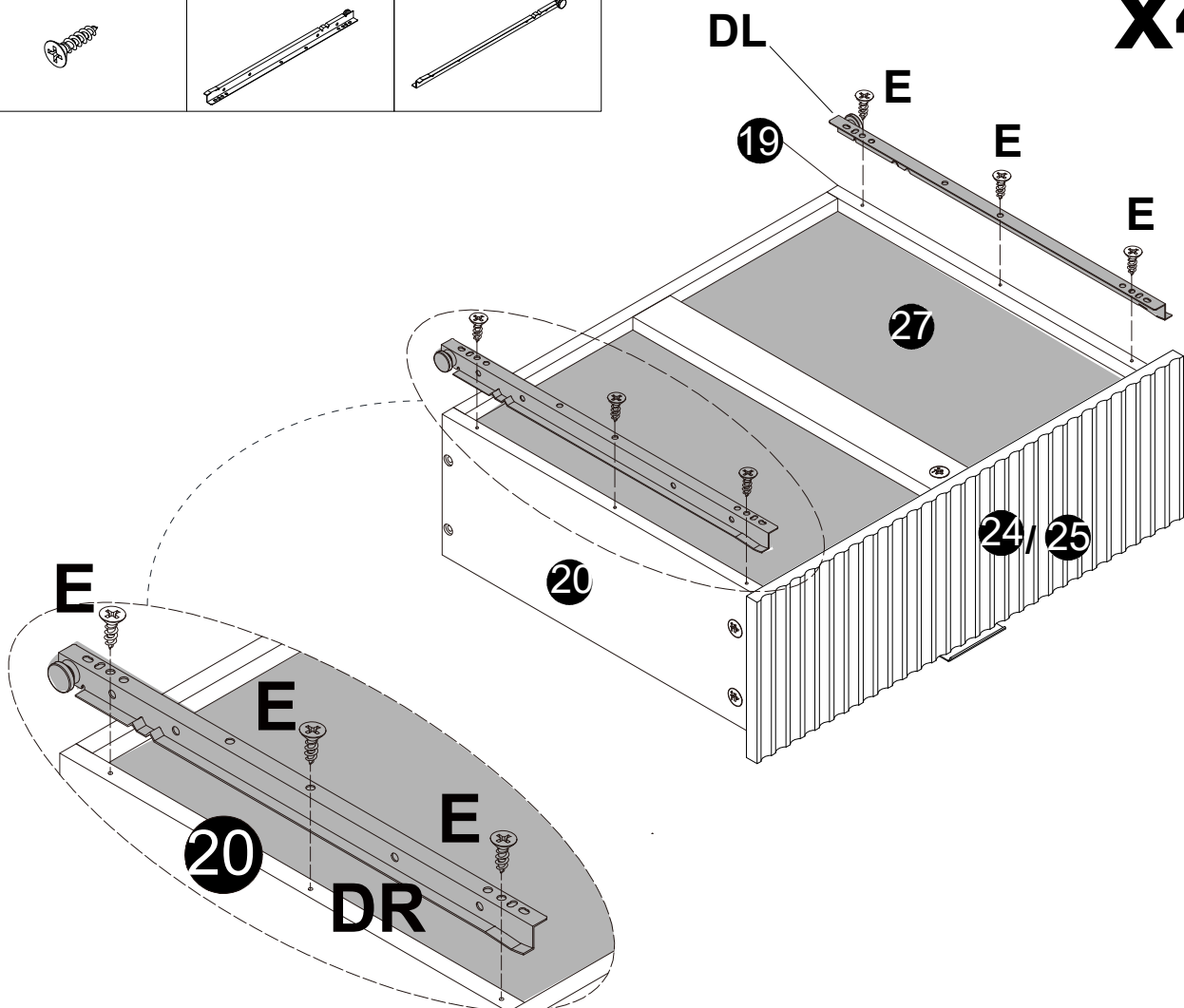

A x12

B x12

D x12

04

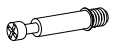

x3

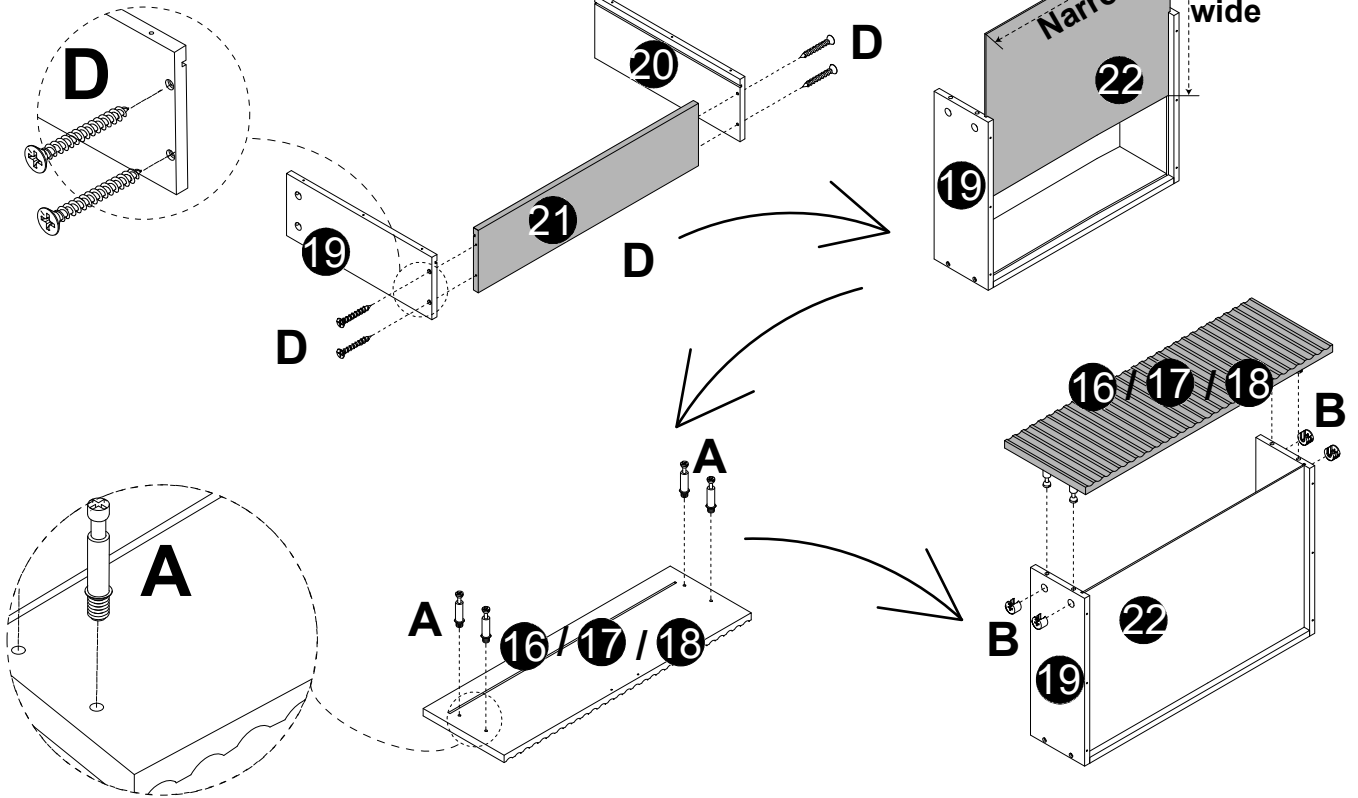

F x3

05

x3

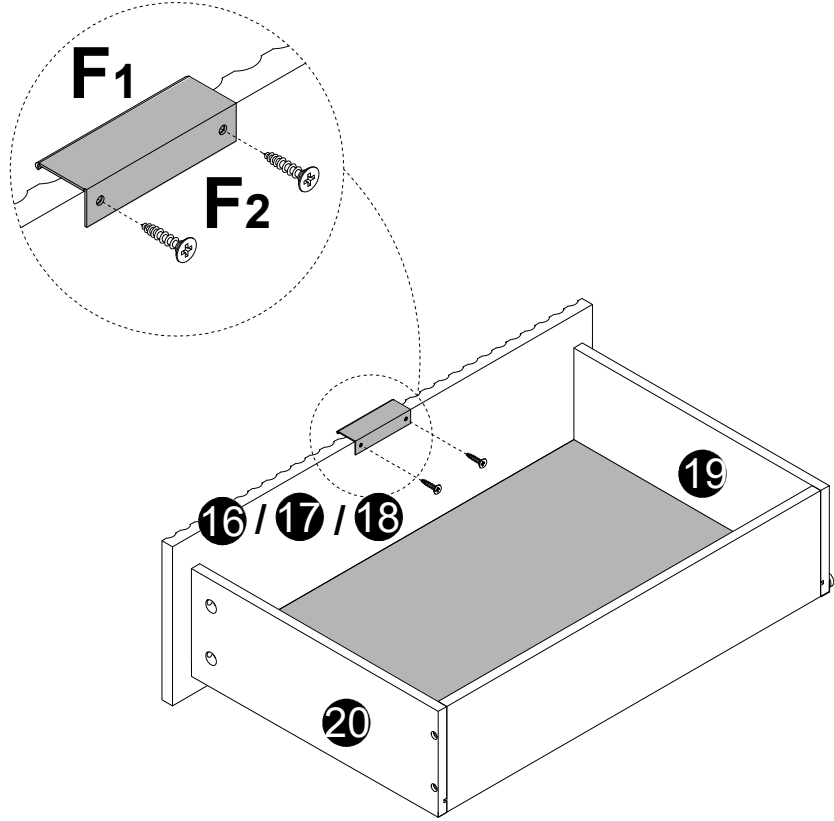
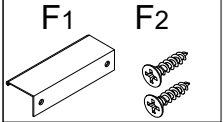

E x18

DL x3

DR x3

x3

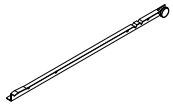
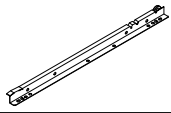

DL

E

E

E

19

22

E

E

E

20

DR

20

16 / 17 / 18

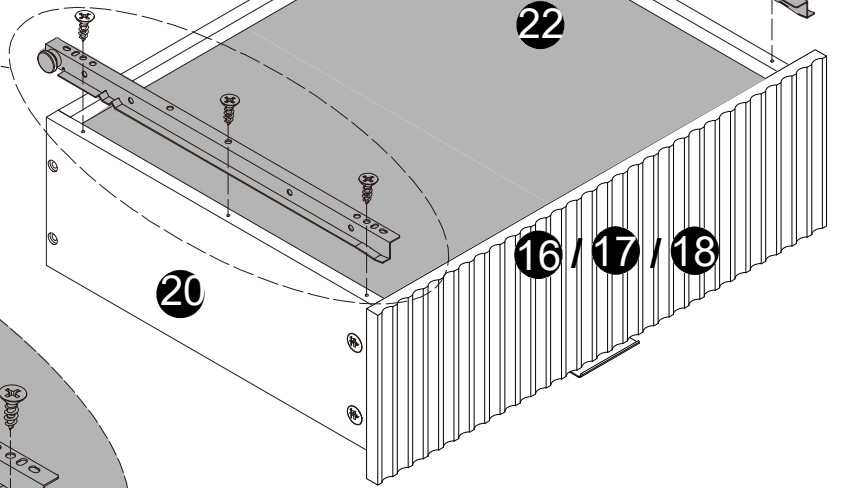
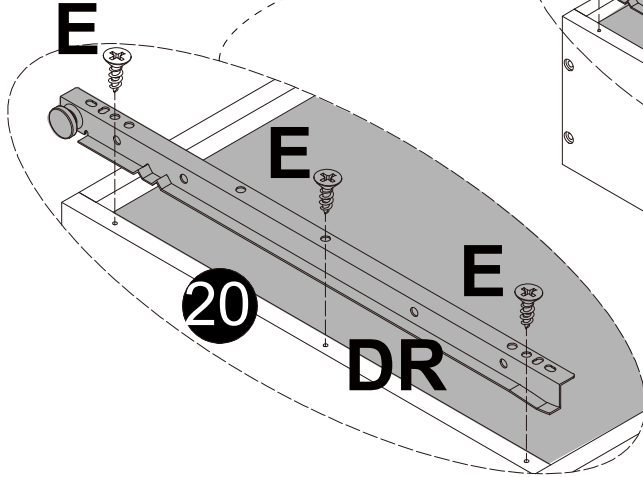

E x18

CL x3

CR x3

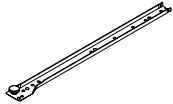
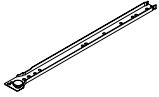

E

E

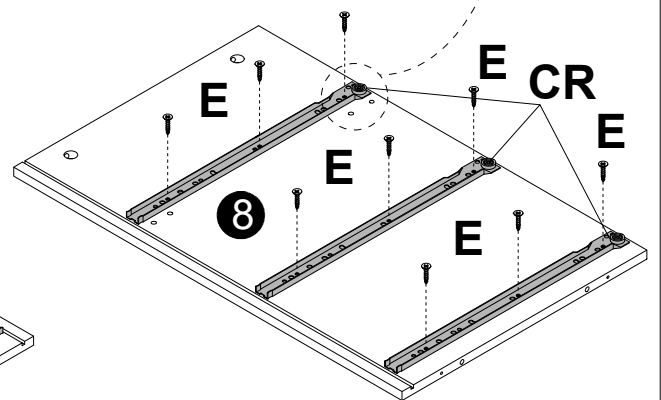
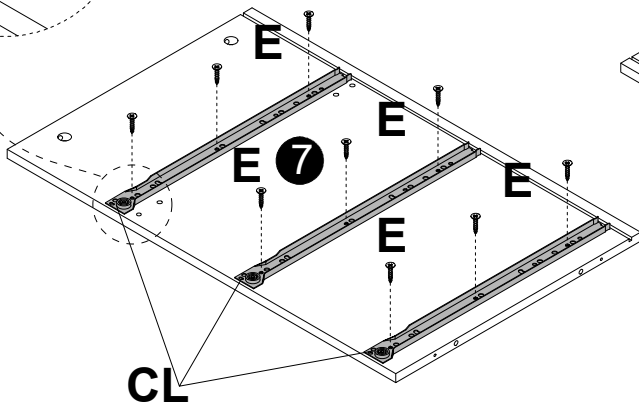
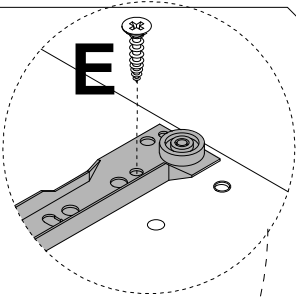
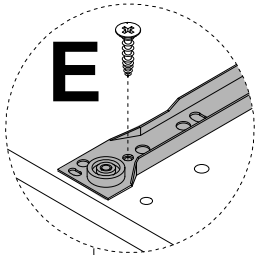

CL

8

CR

A x6

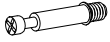

08

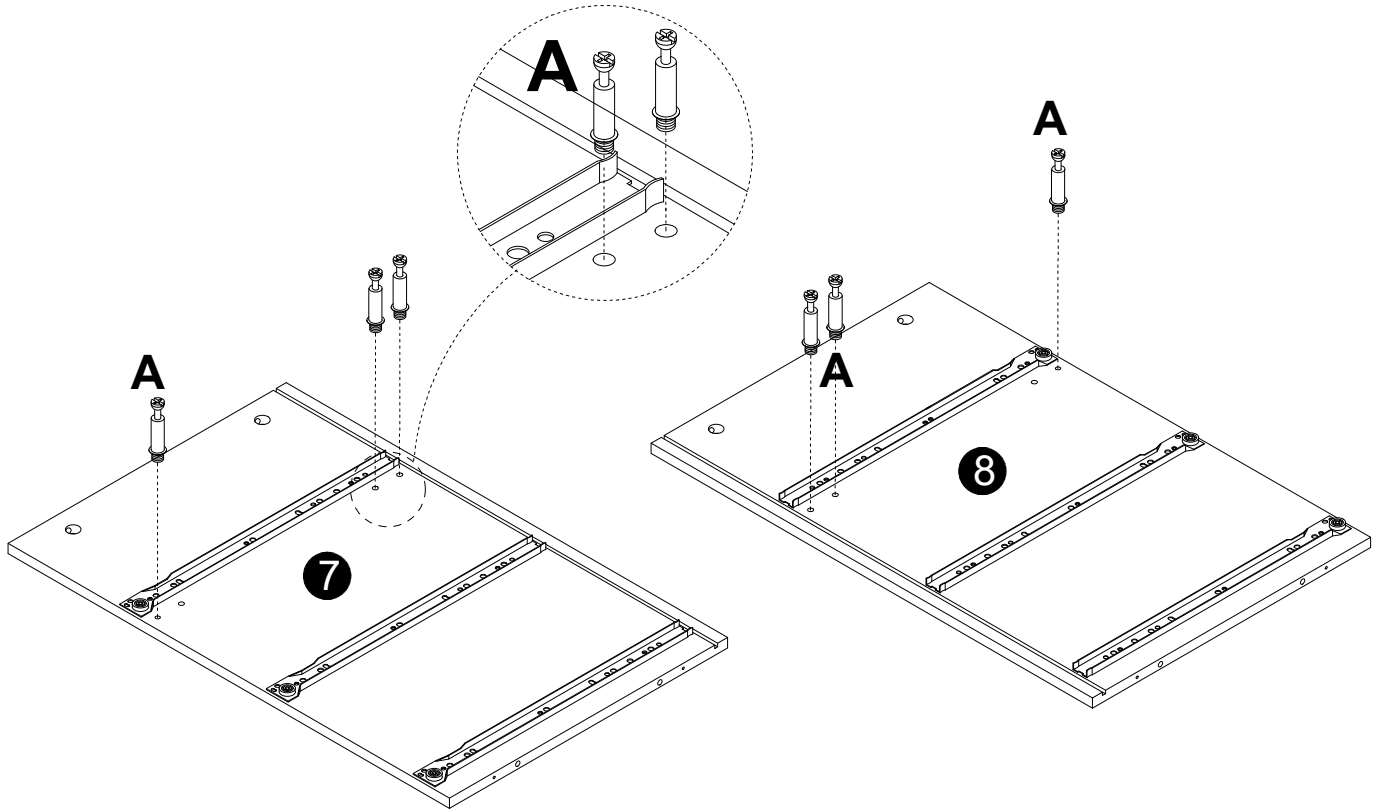

E x6



CL x2

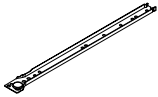

09

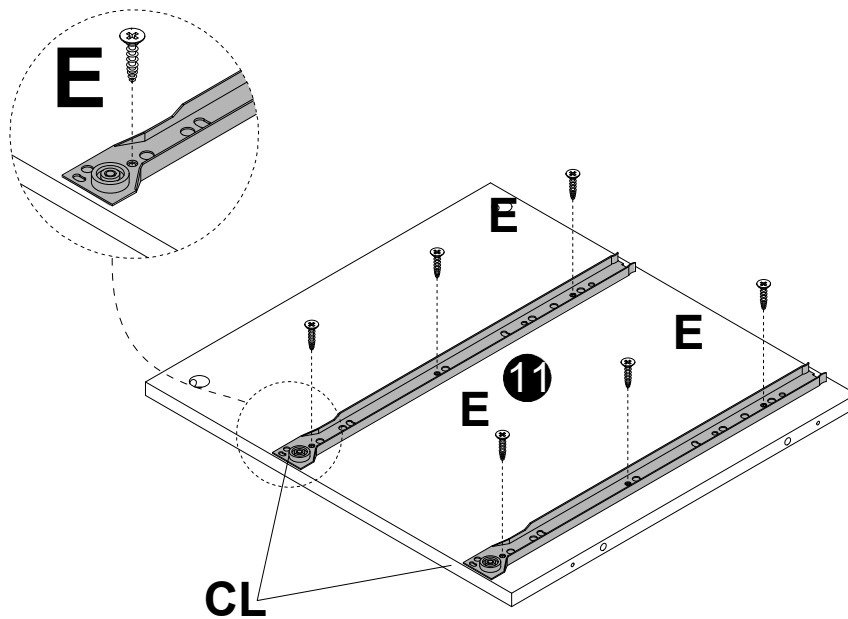

E x6

CR x2

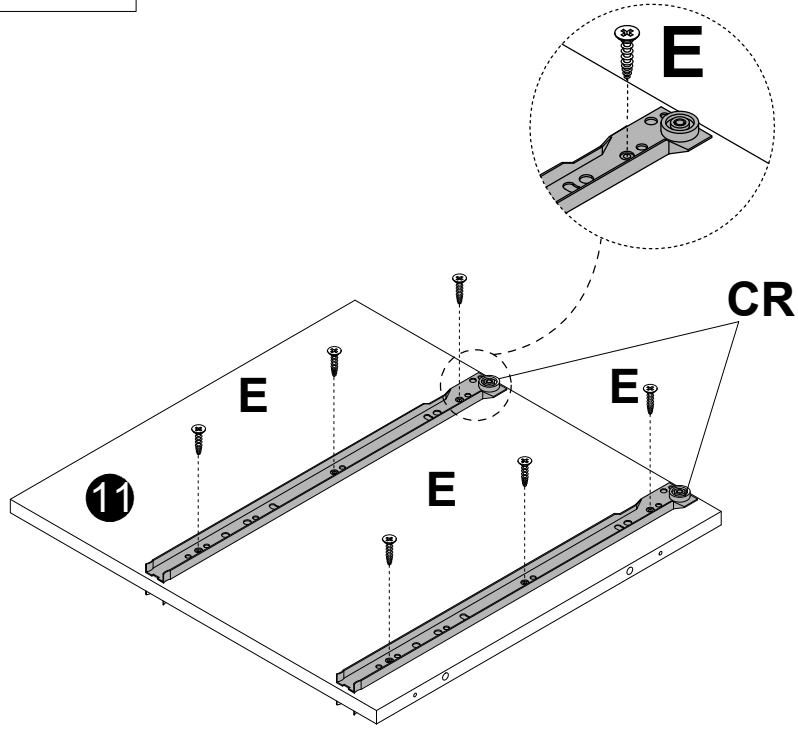
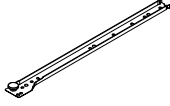

11

E

E

CR

E

E x12

CL x2

CR x2

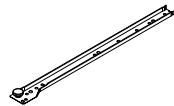
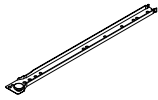

x2

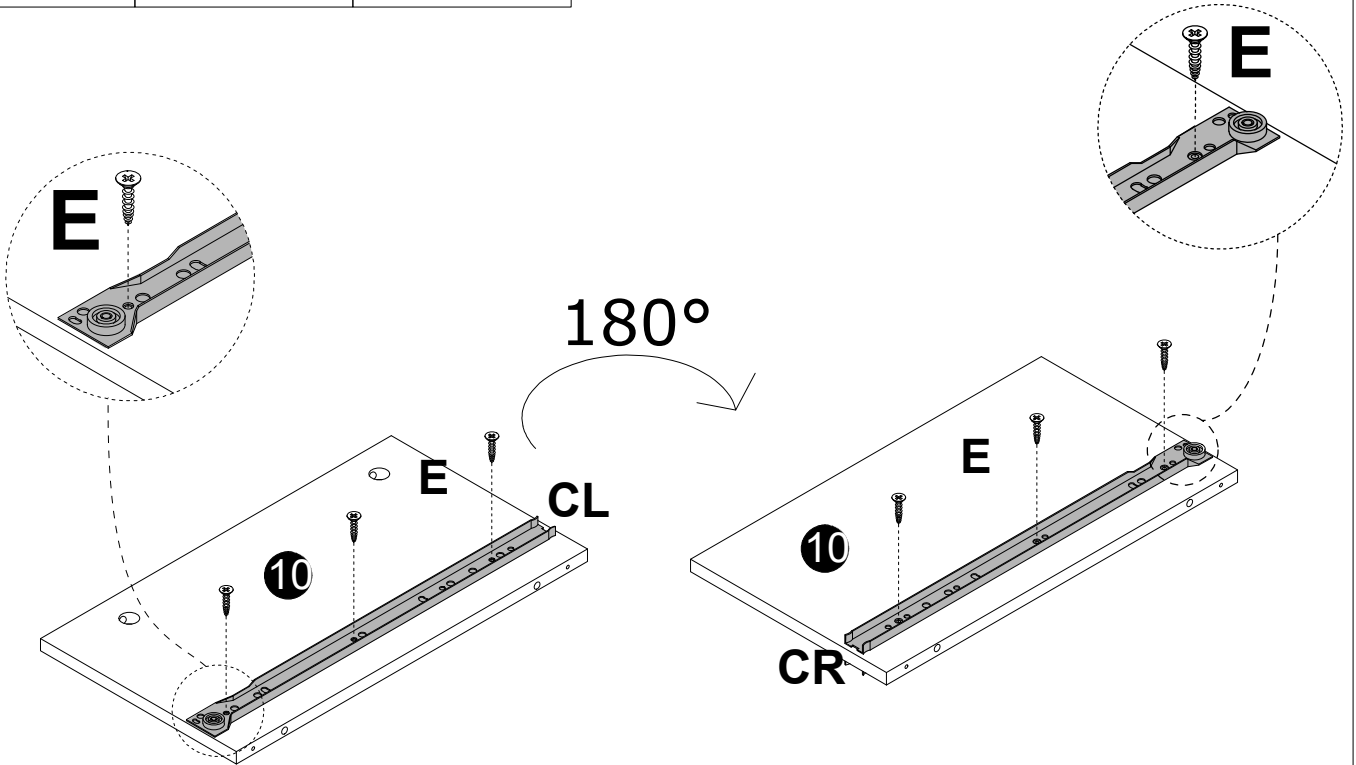

E

180°

10

E

CL

10

E

CR

E

A x2

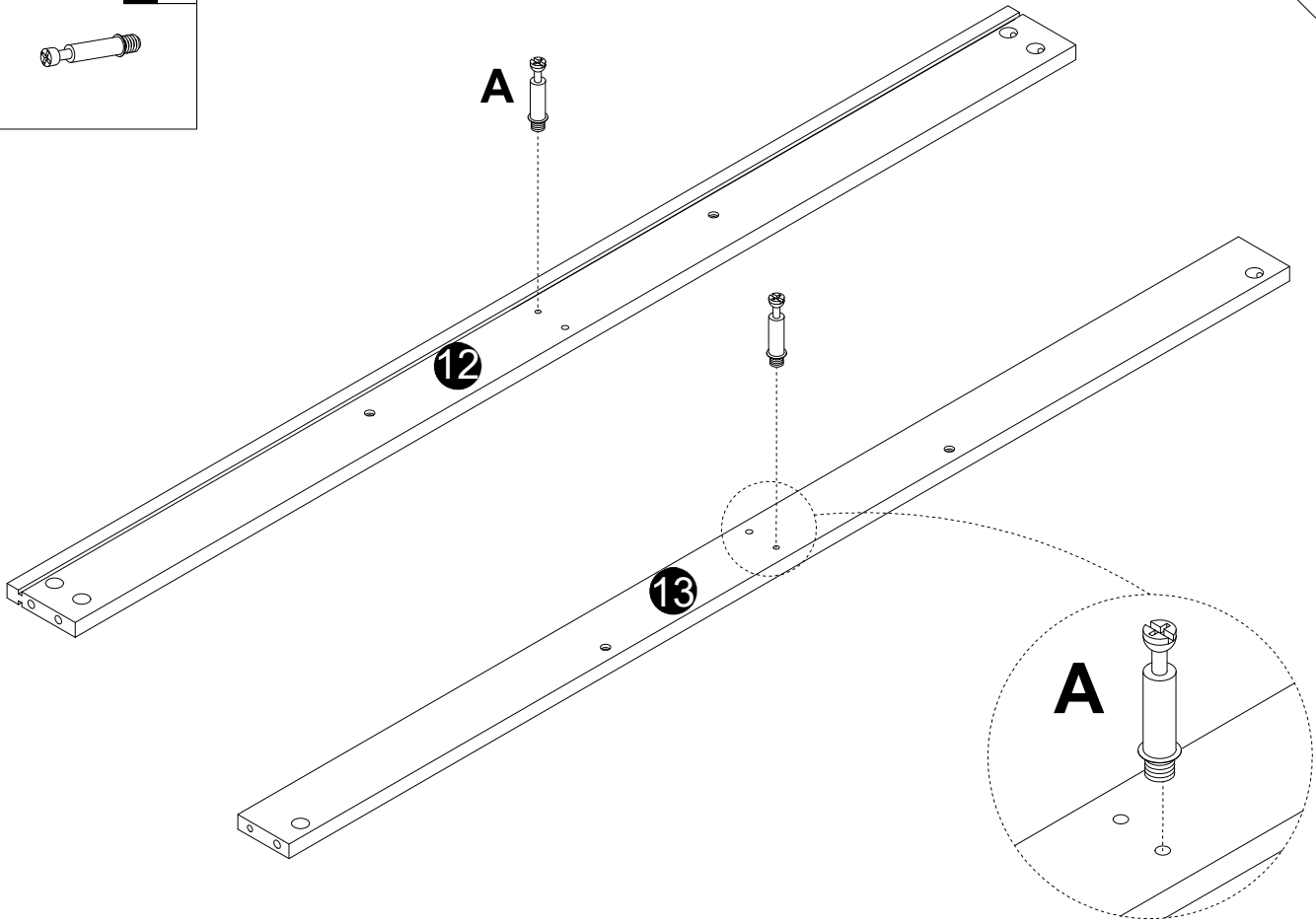
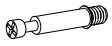

B x2

C x2

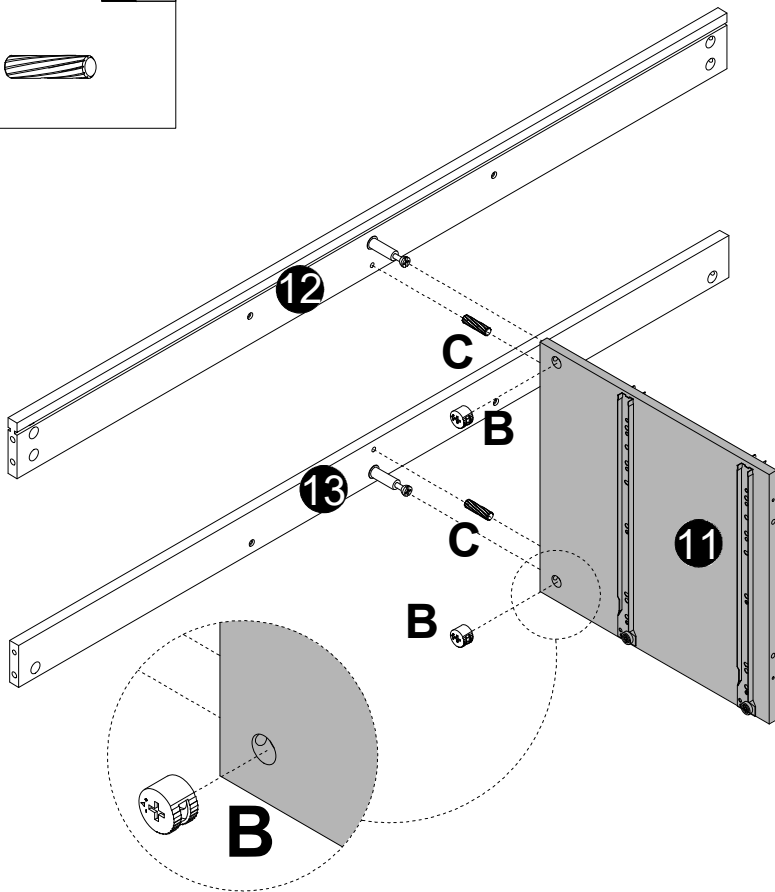

B x6

C x2

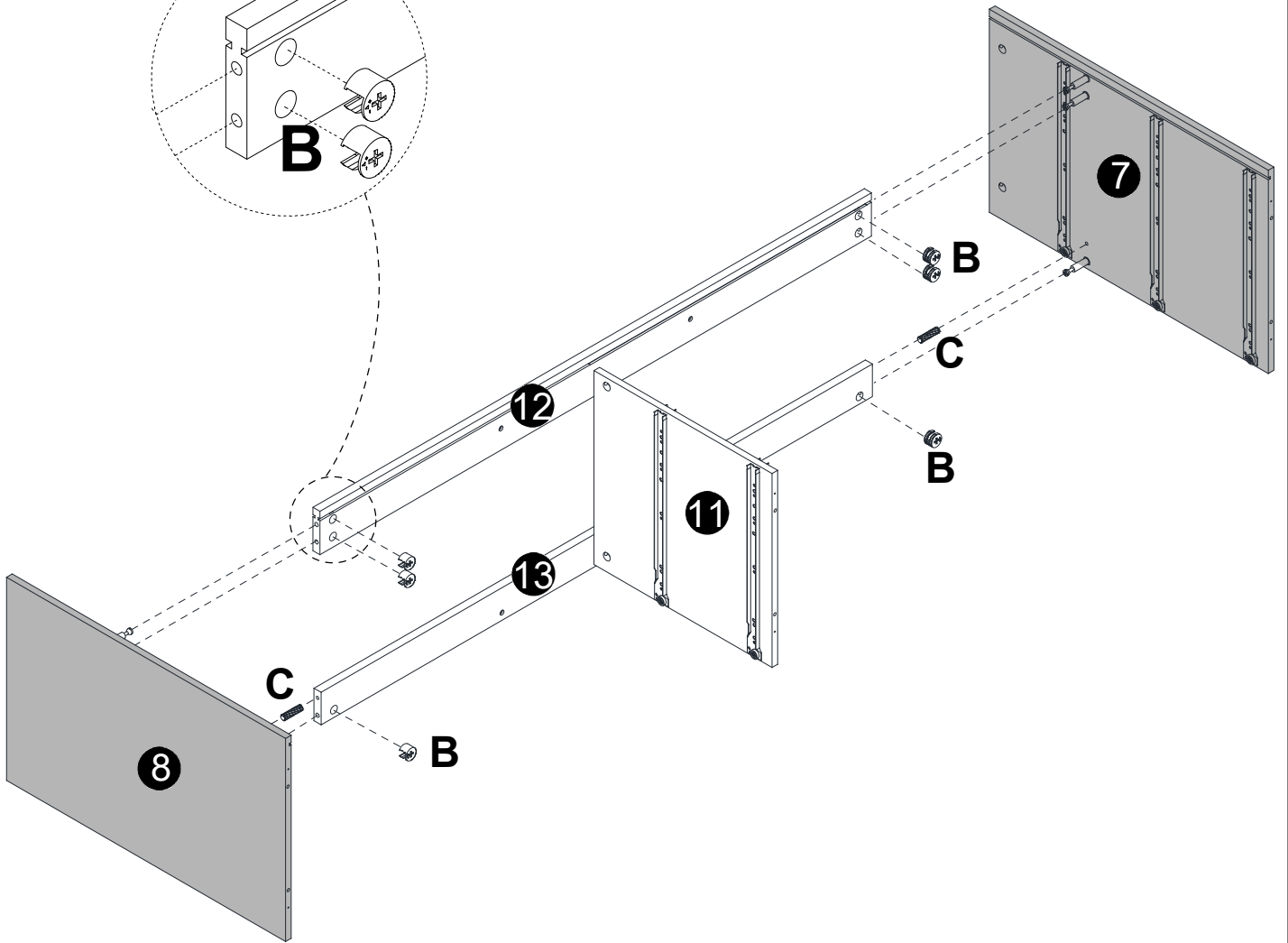
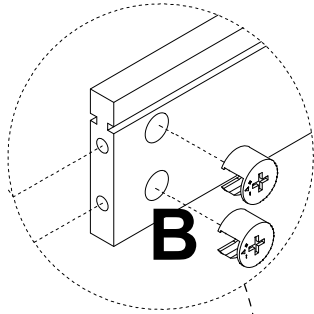

C x4

D x4

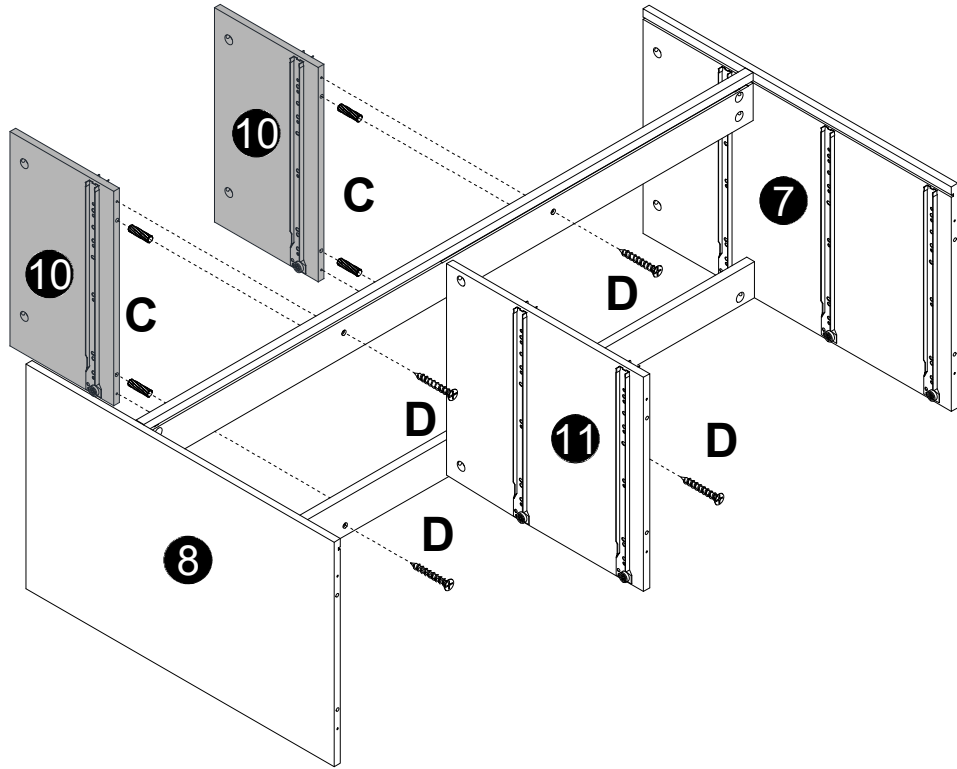
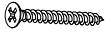

A x16

B x8

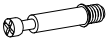

x2

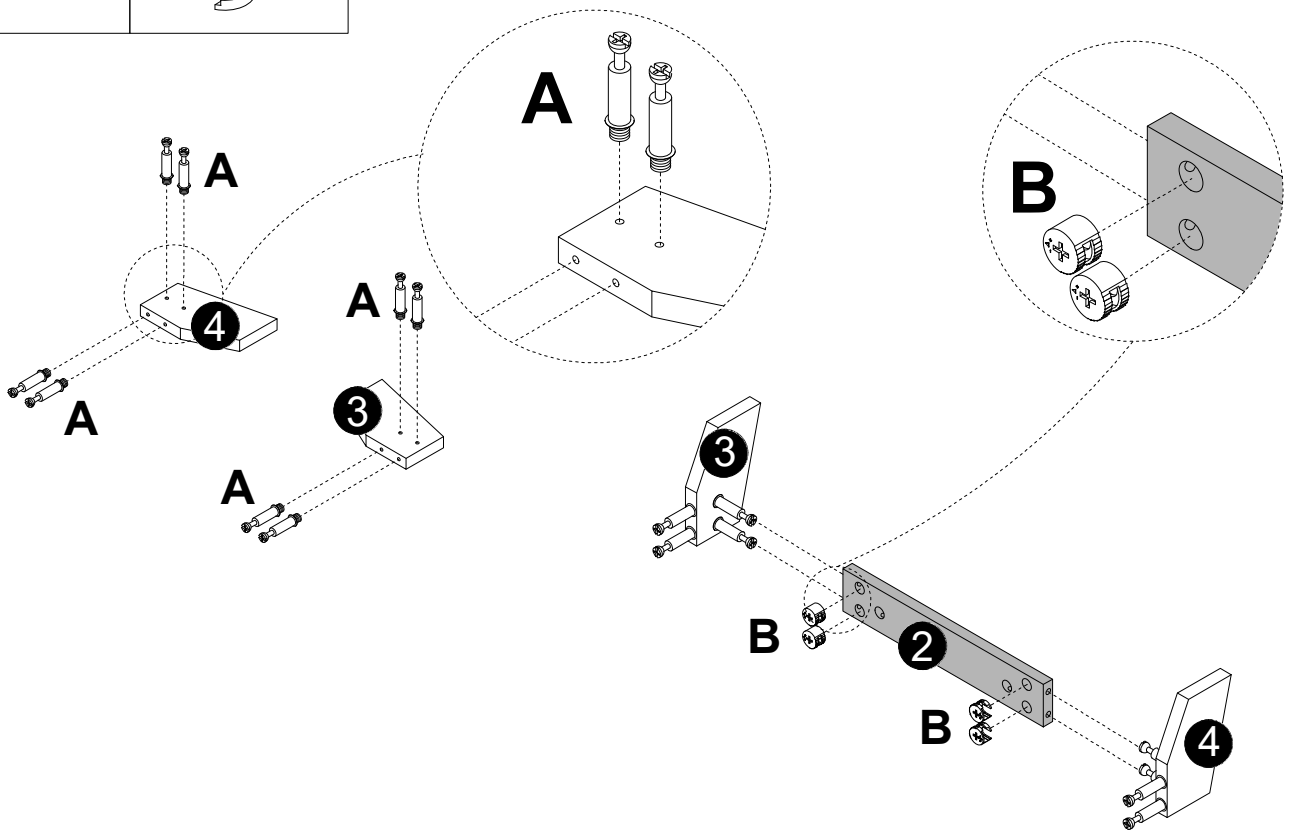

B x8

17

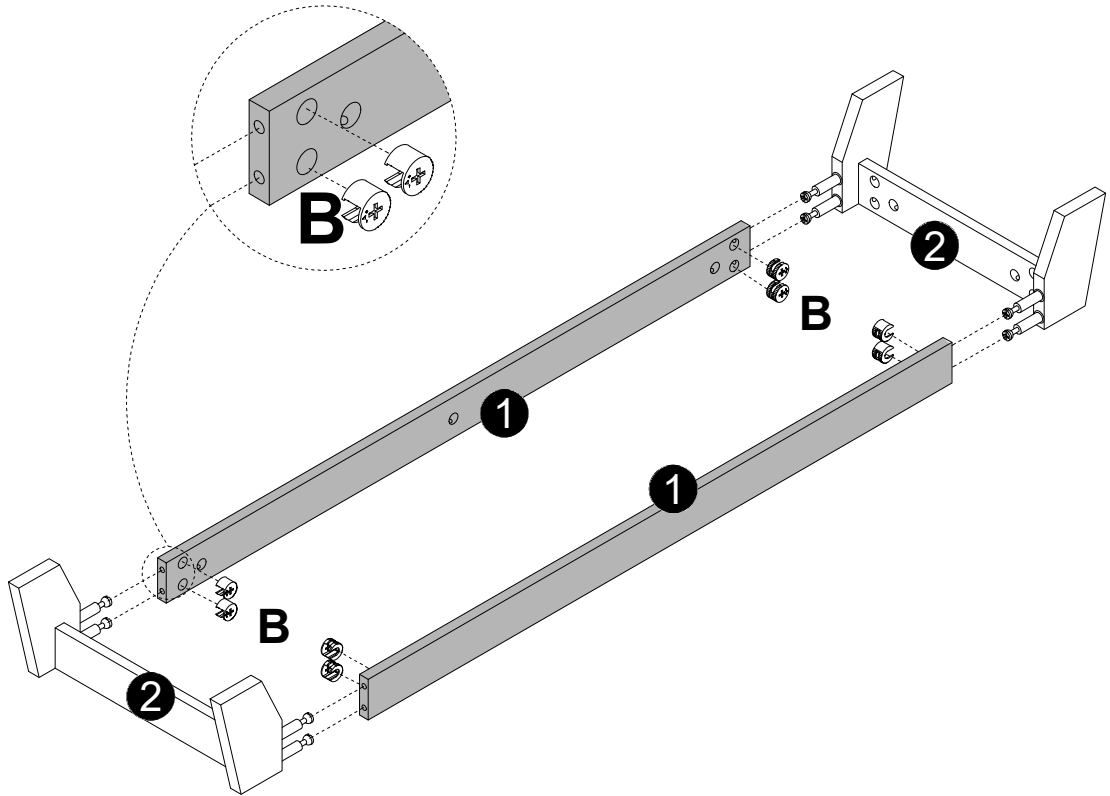

A x10

18

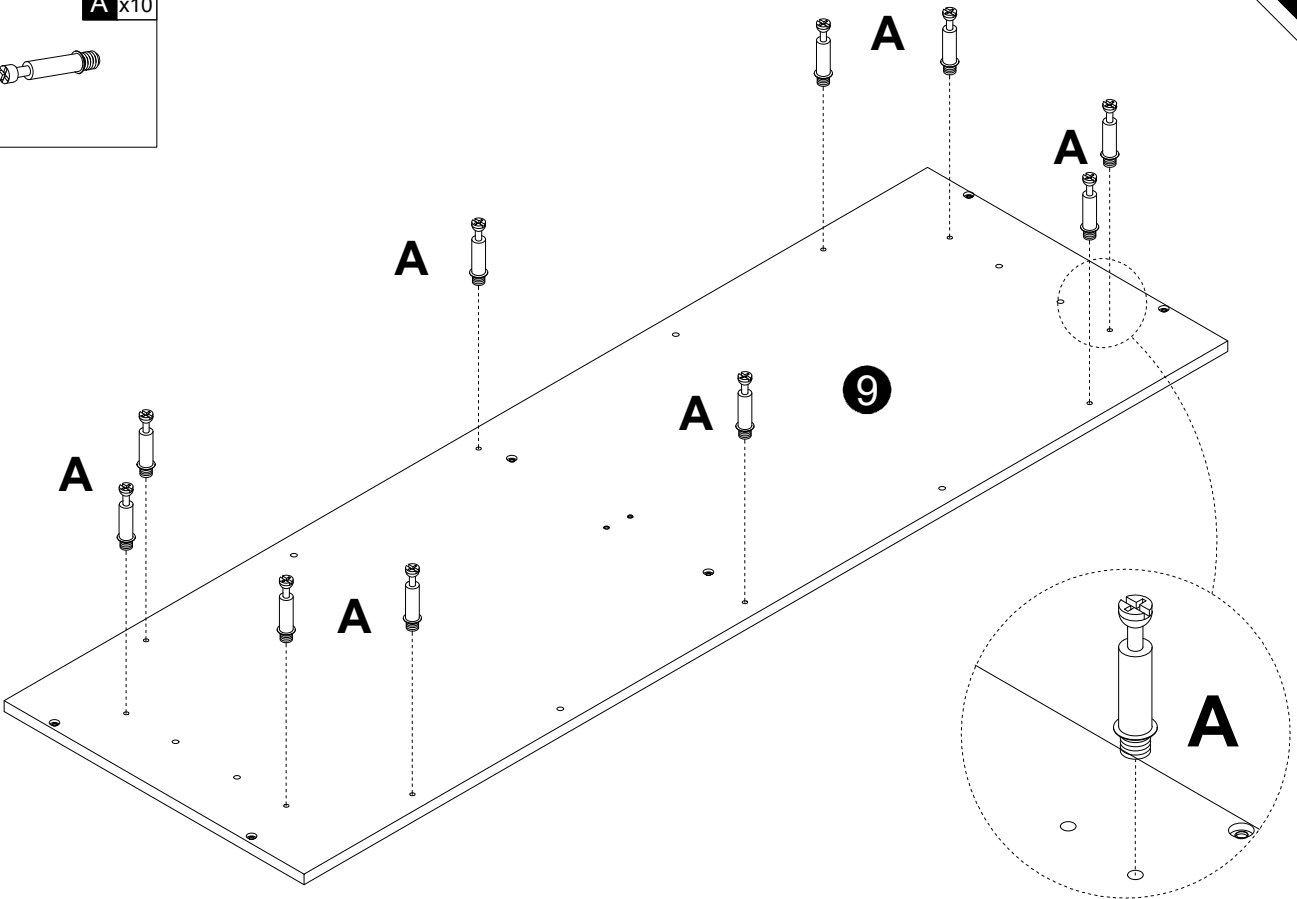
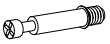

B x10

C x8

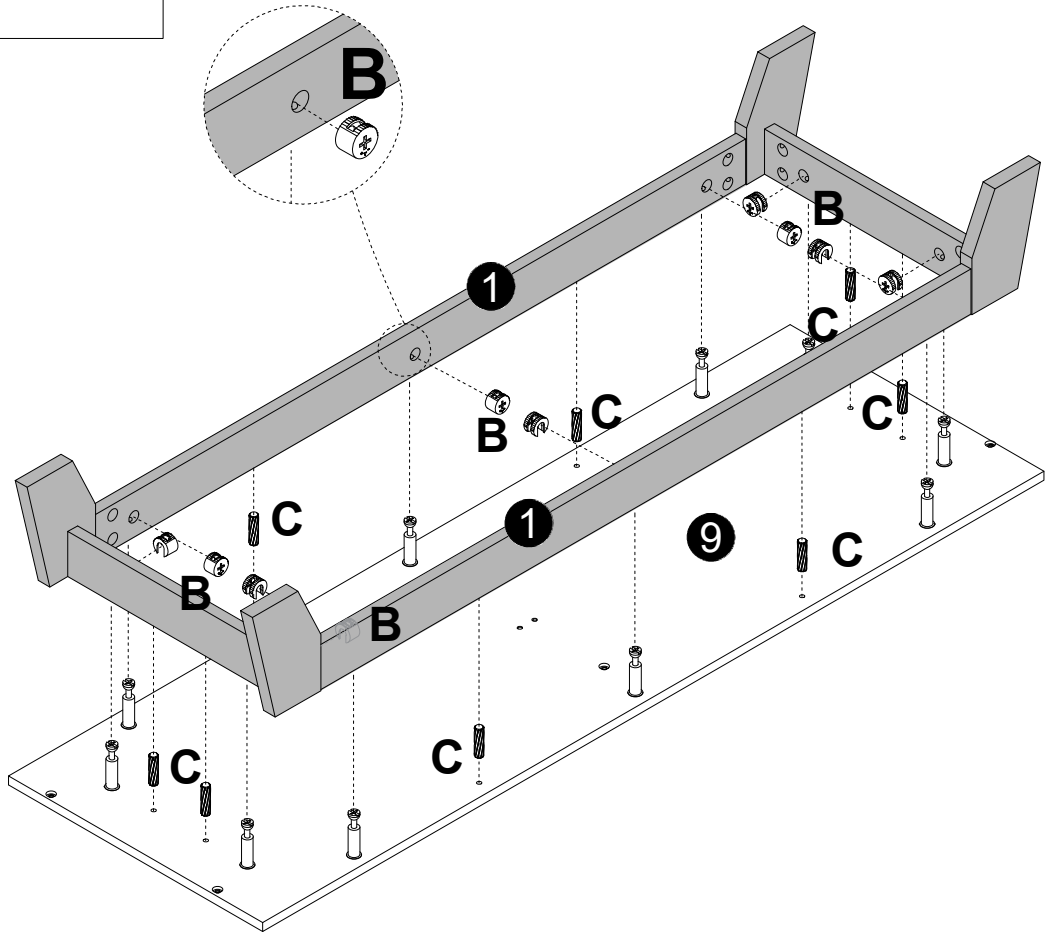

D x2

K x1

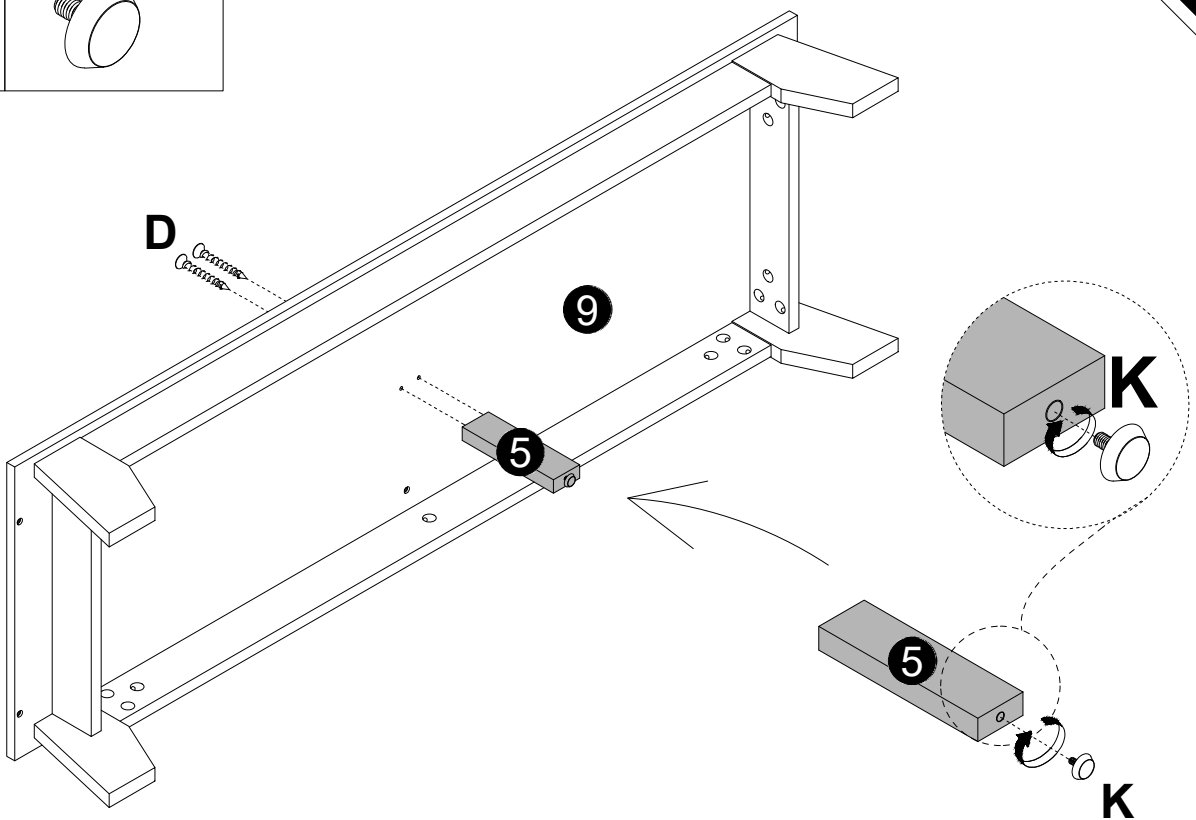

C x6

D x6

M x4

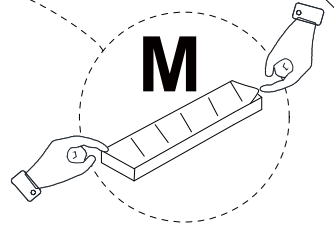
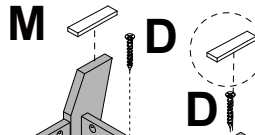
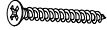

Remove the protective layer from one side of the pad and glue the pad down

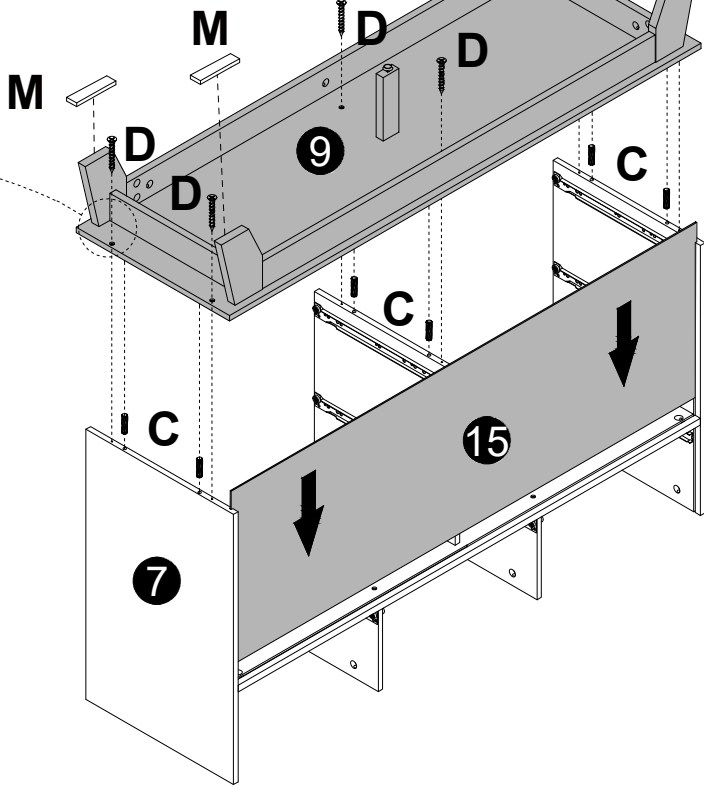
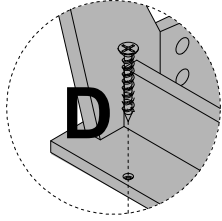

C x8

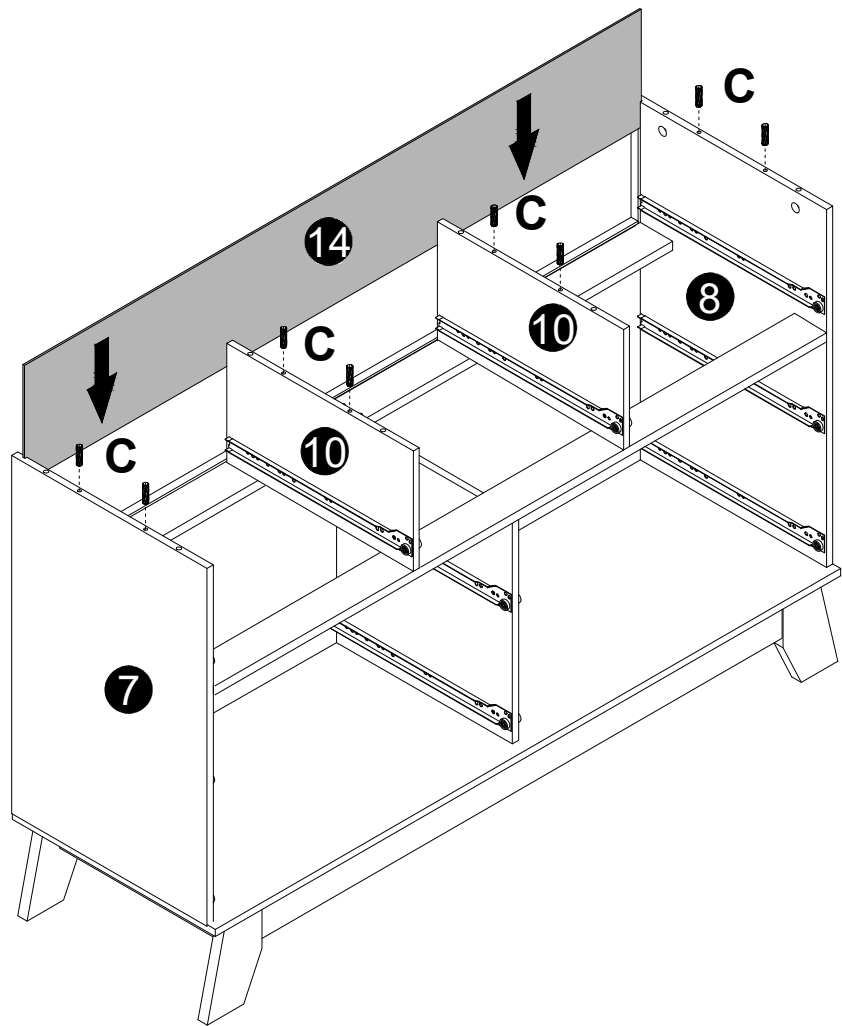

A x8

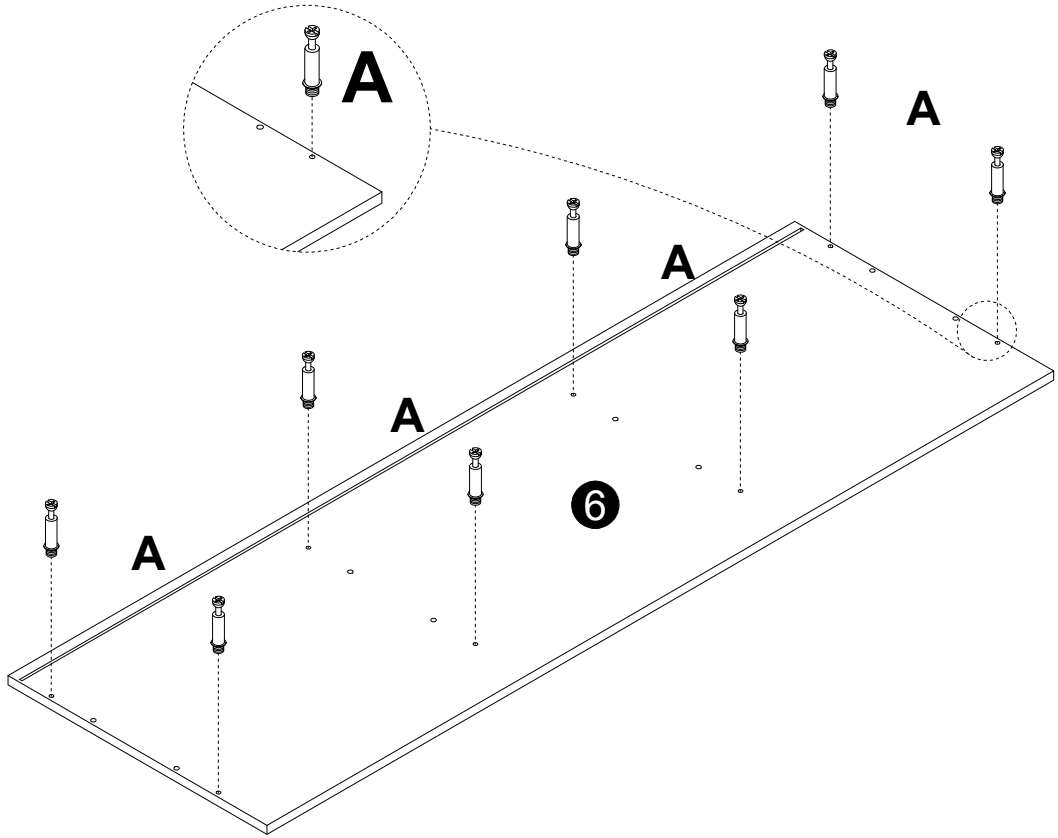
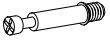

B x8

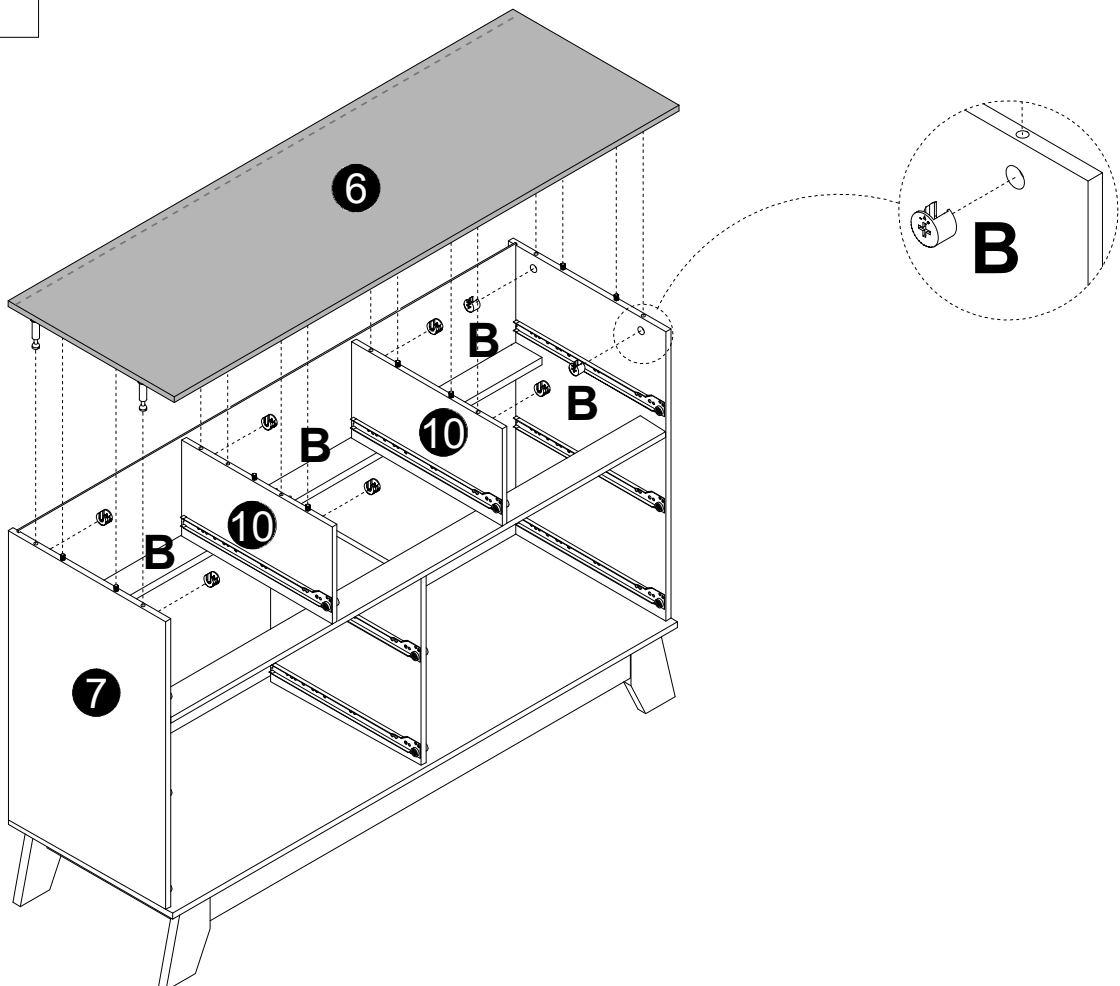

H x10

H1

H2

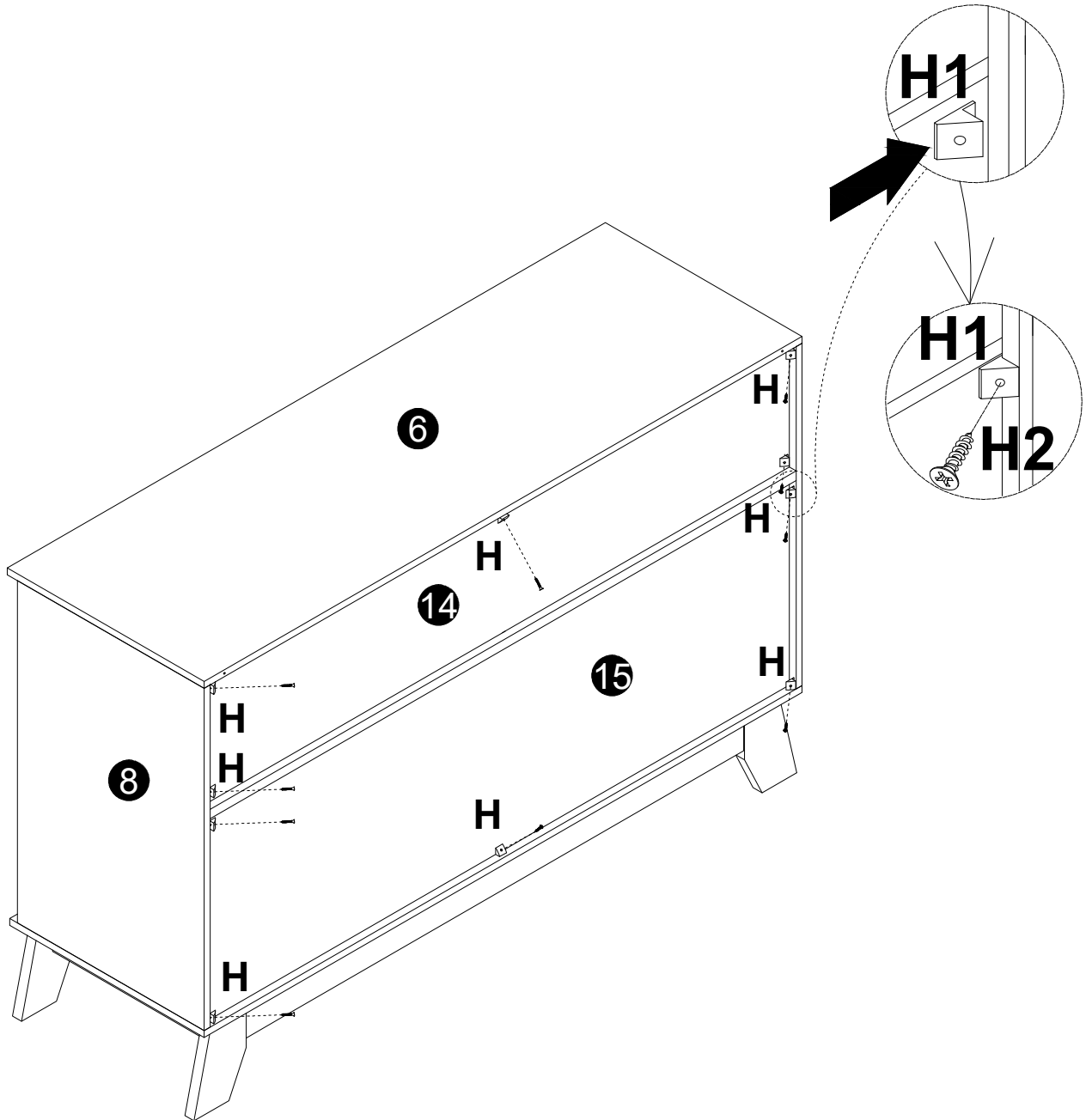
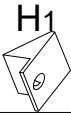

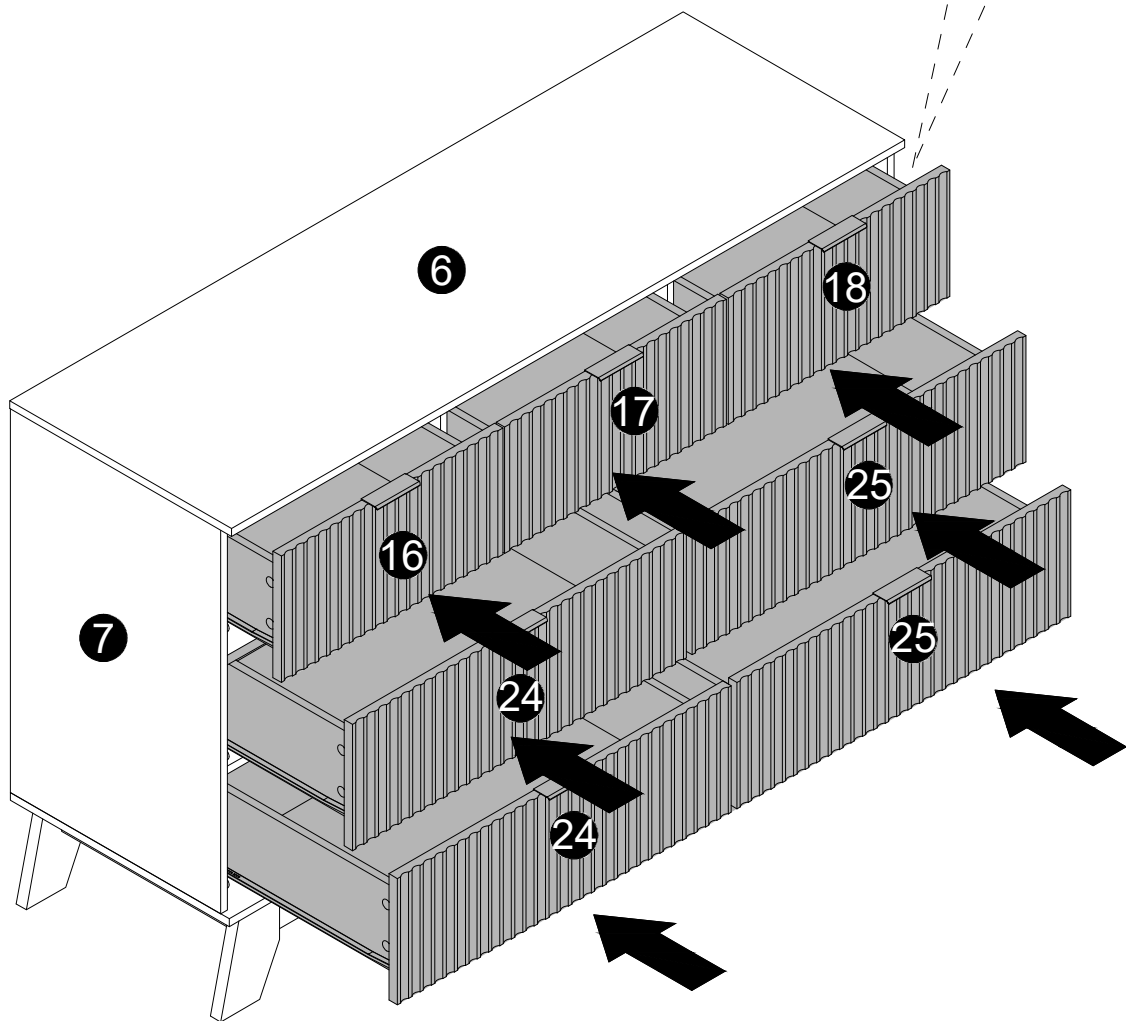
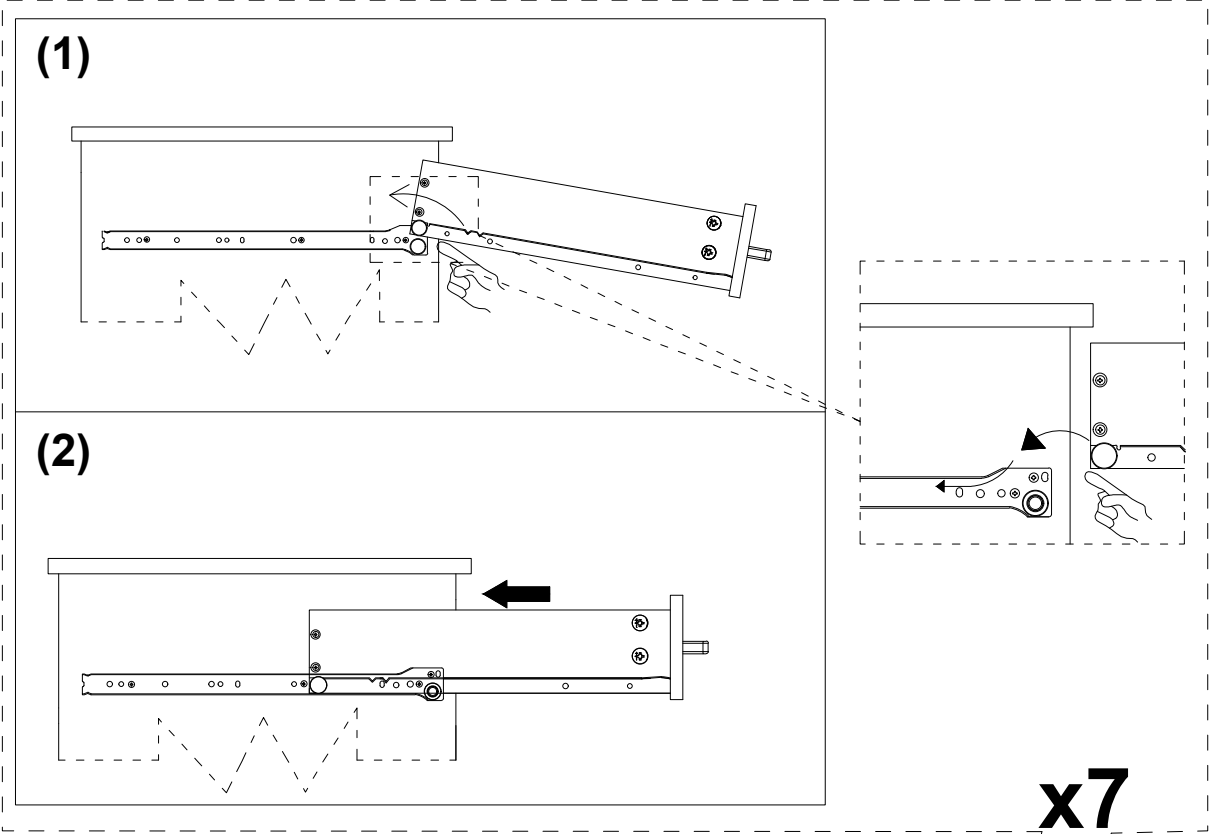

D x2



I x2



J x2



G x2

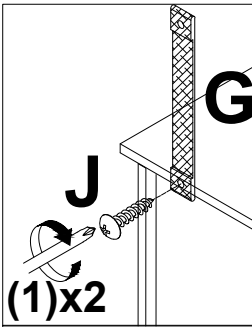

First fix the anti-rewind screw in the reserved hole of the product.

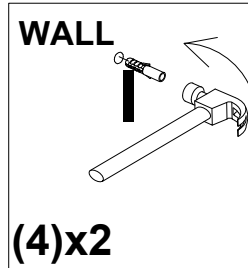

Then, put the expansion bolt into the hole

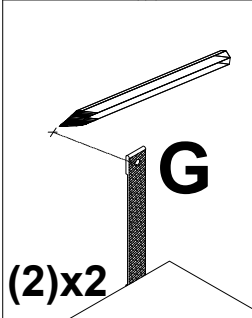

then, use a ruler to measure the approximate height of the product on the wall, and then mark it with a pen.

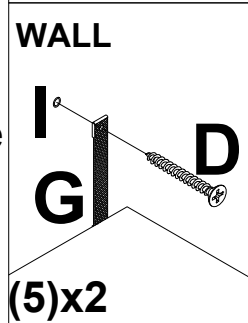

Finally, pass the matching screws through the "anti-rewind" and tighten them to fix them on the wall.

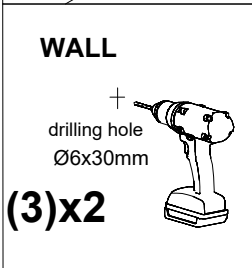

WALL

drilling hole
Ø6x30mm

Then use a tape drill to make holes in the wall that are suitable for the product screws.

