

Assembly Instructions

Twin or Full Mission Bed



PARTS (included)

- (A) Headboard (2)
- (B) Post (4)
- (C) Side Rail (2)
- (D) Slat Roll (1)



TOOLS NEEDED

Power Drill and/or Screwgun
Flat Head Screw Driver
Hammer

HARDWARE (included)

- (a) 1/4" x 2 3/4" Bolt (8)
- (b) 1/4" x 3 1/2" Bolt (8)
- (c) Dowel Nut (8)
- (d) Allen Wrench (1)
- (e) Square Drive Bit (1)
- (f) 1 1/2" Wood Screw (30)
- (g) Wooden Caps (8)
for Full Bed
for Twin Bed (4)



STEP 1

Attach the posts to the headboards using 3 1/2" bolts. (See photos 1 & 2.) Make sure the notches on the posts both turn the same way. Tighten using the Allen wrench.

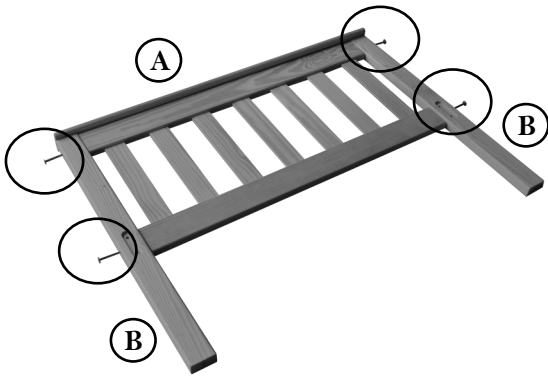

photo 1

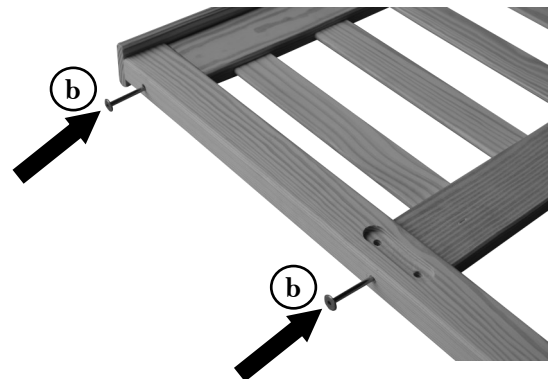

photo 2

STEP 2

You will need someone to help you with this step. Attach the side rails to the headboard/post assemblies. The side rail ends should fit into the notches in the posts. (See photo 3.) Insert a dowel nut into each of the 4 holes on the inside of the side rail. (See photo 4.) Push them in until the hole in the dowel nut lines up with the hole in the post. Now put 2 3/4" bolts through the post into the side rail (see photo 5) and thread them into the dowel nut. Tighten with the Allen wrench. You will need the flat head screw driver to rotate the dowel nuts slightly either way to get the correct alignment.

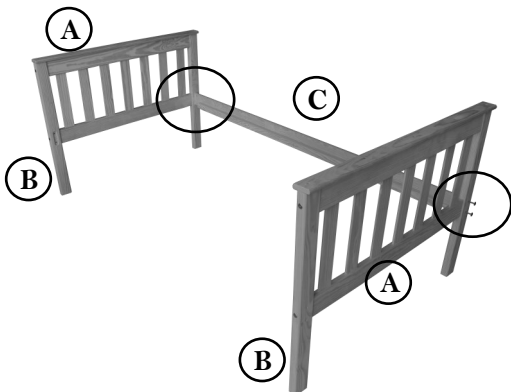

photo 3

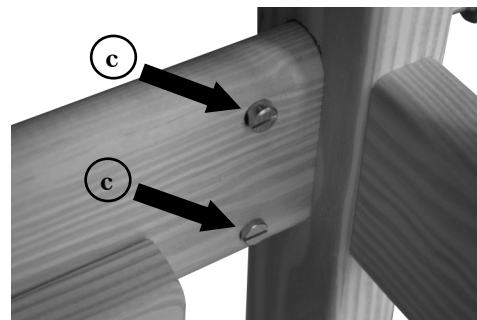

photo 4

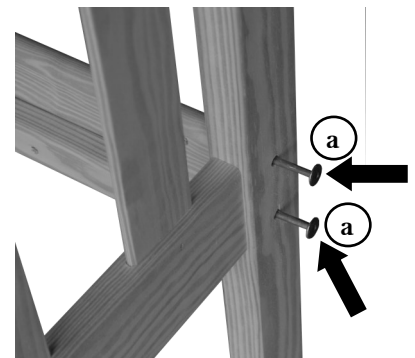

photo 5

STEP 3

Cut the wrap on the slat roll and unroll them onto the bed frame with the string facing up. (See photo 6.) Fasten each slat at both ends to the side rails with 1½" screws (photo 7) keeping the string taut as you go along. Use your power drill or screwgun to drive the screws with the included square drive bit. Note: The screws are self drilling. You shouldn't need to predrill, however, doing so will make them easier to drive. Use drill bit no larger than 7/64".

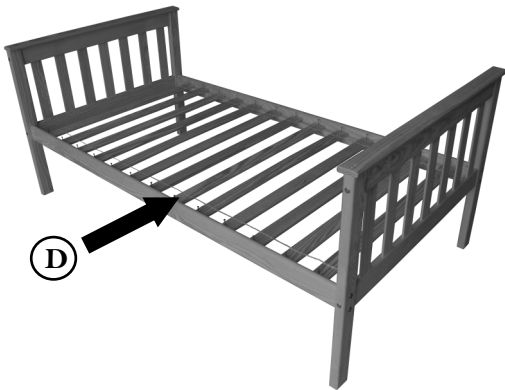

photo 6

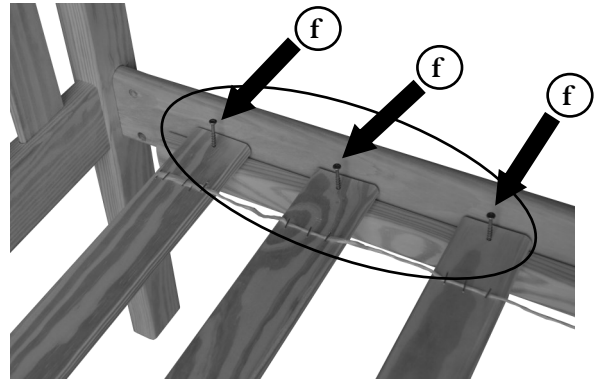

photo 7

STEP 4

Fasten the top of the headboards to the posts using 1½" screws. (See photo 8.) Put wooden caps into the large holes on top of the headboards. (See photo 9.) If you bought a full bed, the headboards will each have 4 of these holes. You may have to tap the caps with the hammer to set them properly.

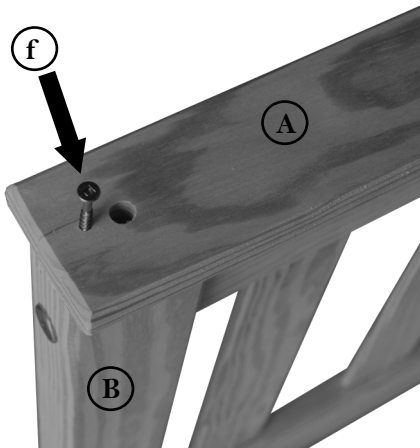

photo 8

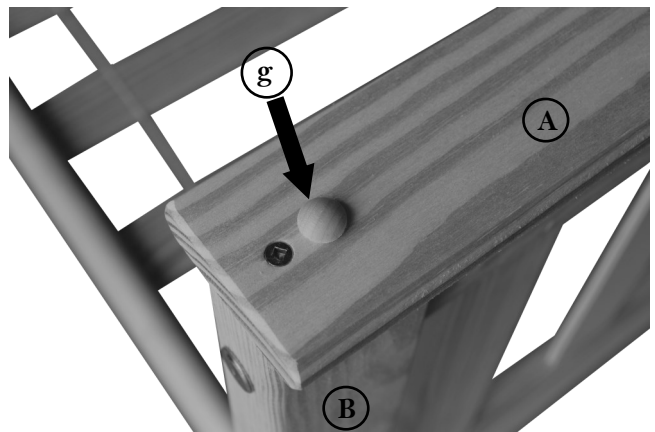

photo 9