

# Installation Manual Manual de Instalación

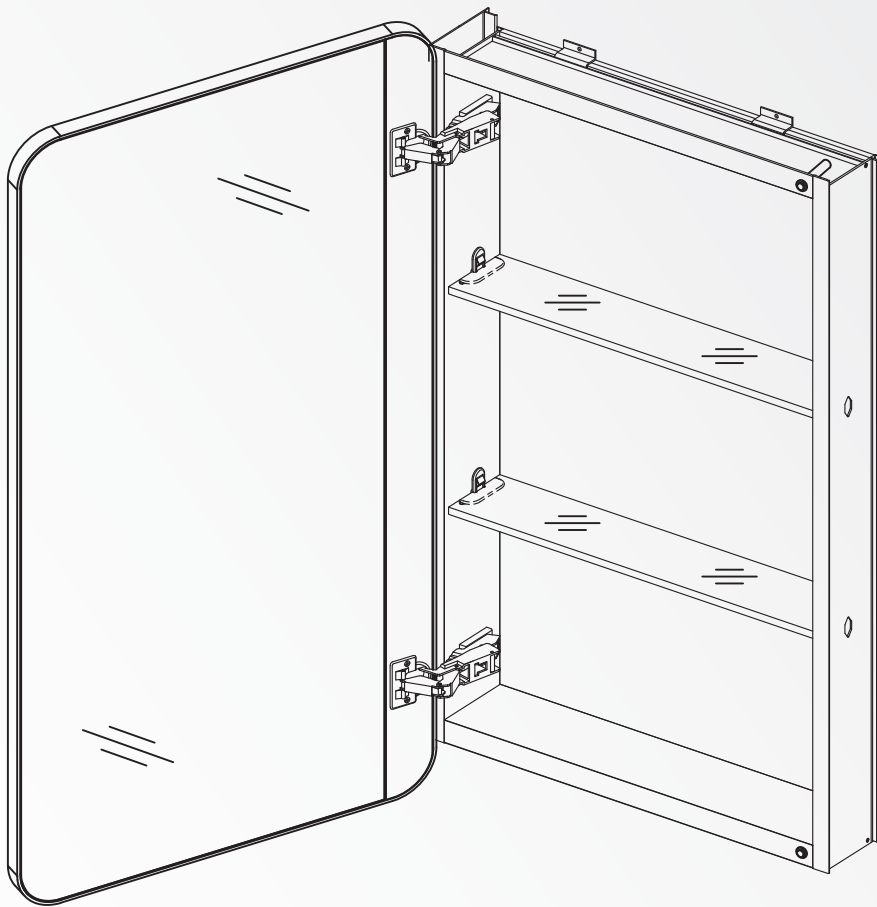

FRAMED  
MEDICINE CABINET

---

ARMARIO DE  
MEDICAMENTOS CON MARCO

---

# TABLE OF CONTENTS

---

## 01 English

|                                  |     |
|----------------------------------|-----|
| Component Details .....          | 1-2 |
| Pre-Installation Guidelines..... | 3   |
| Installation Steps.....          | 4-9 |





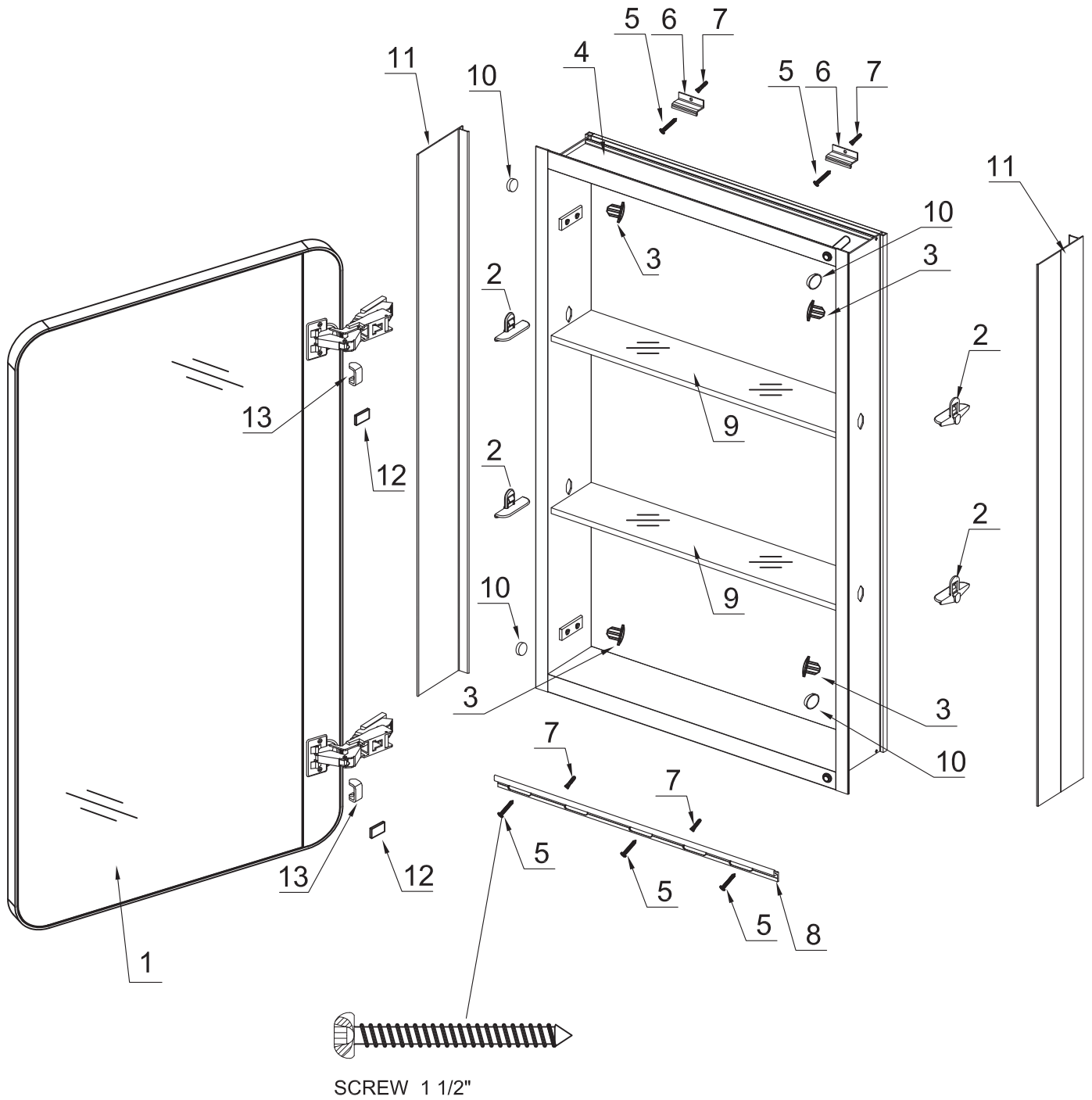

## 02 Español

|   |       |
|---|-------|
| Detalles del componente.....                | 10-11 |
| Instrucciones previas a la instalación..... | 12    |
| Pasos de instalación.....                   | 13-18 |

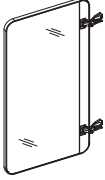
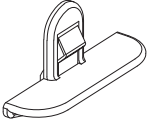
# Detailed Diagram of Aluminium Mirror Components

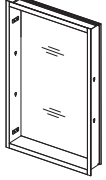
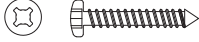

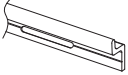
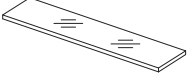

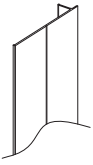
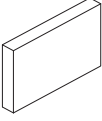
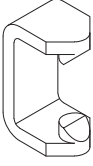
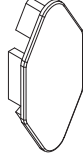

PARTS LIST.

|   |   |   |   |   |
|---|---|---|---|---|
|  |  |  |  |  |
| DOOR (1 PCS)  | CLEAR SHELF CLIP (4 PCS)  | HOLE PLUG (10 PCS)  | CABINET (1 PCS)   | SCREW #10-1 1/2 (5 PCS)   |
|  |  |  |   |  |
| TOP Z-CLIP (2 PCS)  | WALL PLUG (5 PCS)   | MOUNTING BRACKET (1 PCS)  | GLASS SHELF (2 PCS)   | SCREW HEADCOVER CAP (5 PCS)   |
|  |  |  |  |   |
| COVER PLATE (2 PCS)   | COVER CAP (2 PCS)   | 130 DEGLIMIT CLIPS (2 PCS)  | DECORATIVE COVER ( 0 pcs /4 pcs /6pcs )   |   |

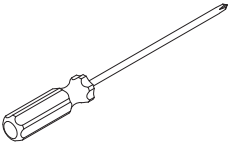
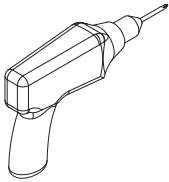
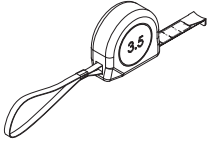
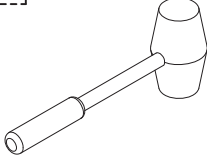
WARNING: SAFETY GLASSES SHOULD ALWAYS BE WORN WHEN WORKING WITH A MEDICINE CABINET.

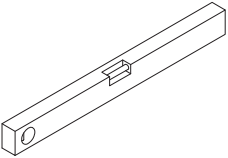
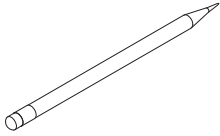
RECOMMENDED TOOLS:

|   |   |   |  |   |
|---|---|---|--|---|
|  |  |  |  |  |
| SCREW DRIVERS   | DRILL   | MEASURE TAPE  | RUBBER MALLET  | 5/16"<br>DRILL BITS   |
|   |  |  |  |   |
| LEVEL   | PENCIL  | SAFETY GLASSES  |  |   |

▪ DETERMINING MEASUREMENT AND DIRECTION:

| HEIGHT         | WIDTH          | DEPTH     | TOLERANCE    |
|----------------|----------------|-----------|--------------|
| <b>23 1/2"</b> | <b>14 1/2"</b> | <b>4"</b> | <b>±1/8"</b> |
| <b>25 1/2"</b> | <b>19 1/2"</b> | <b>4"</b> | <b>±1/8"</b> |

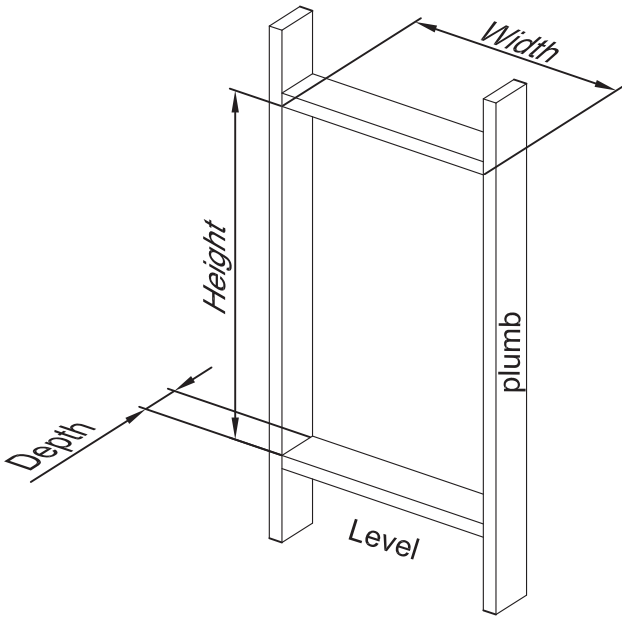

Fig 1

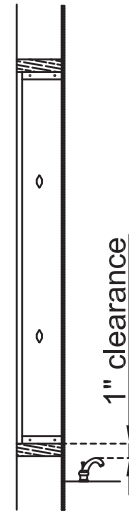
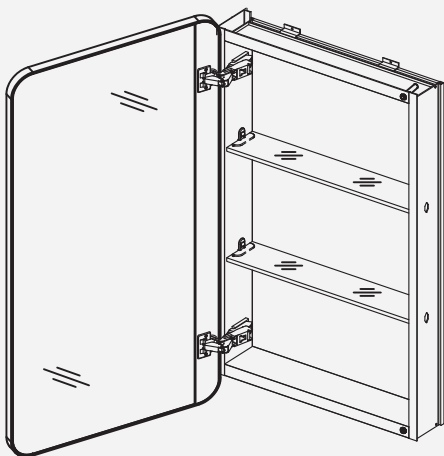
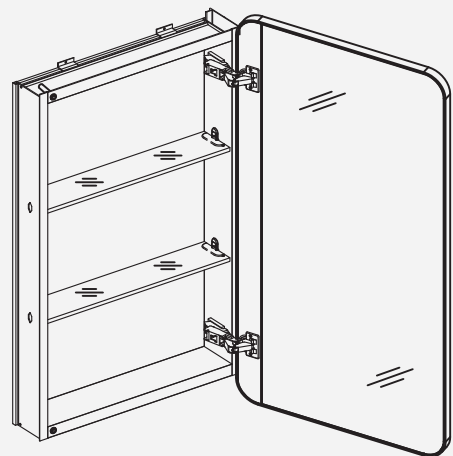

Fig 2

▪ If needed ,please turn over the upside to downside ,you may get the opposite hand installations.



Left hand Installation



Right hand Installation

## RECESSED OR SEMI-RECESSED:

For drywall more than 10-12mm in thickness, please make sure to use specified drywall anchors for installation. For drywall with thickness less than 10-12mm, please make sure to install the brackets on the stud.

1. Pull off the side kits from the cabinet as figure shown.

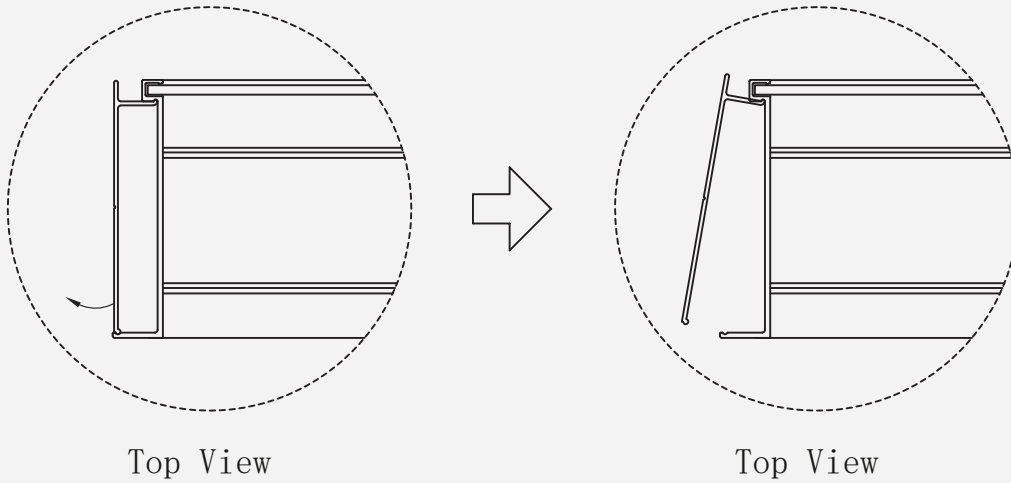

2. Make sure the hinges are on the correct side of the opening for left-hand or right-hand operation. Place the cabinet box into the rough opening. For fully recessed installations, ensure that the cabinet flange covers the rough opening evenly all around (Fig 3). For semi-recessed applications, the mirror edges should align with the wall surface (Fig 4). Use shims as needed.

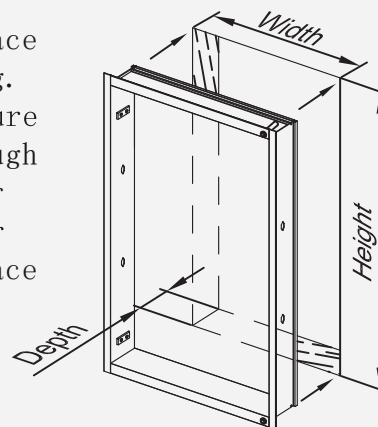

Fig 3

### Semi-recessed

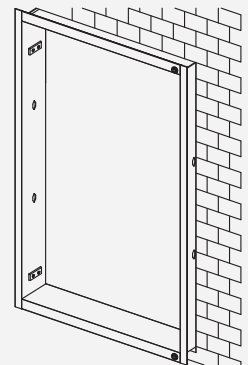
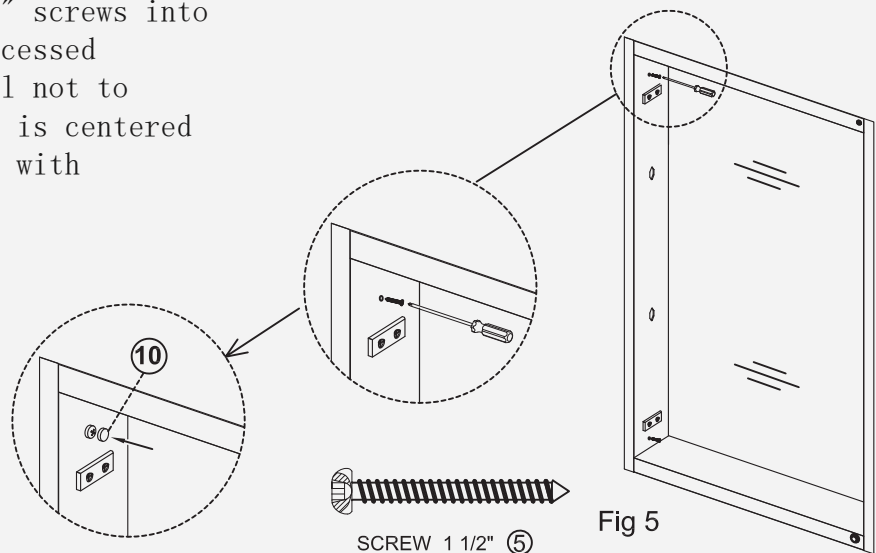

Fig 4

3. Insert four (4) #10 X 1 1/2" screws into four locations provided for recessed installation (Fig5). Be careful not to overtighten. Make sure cabinet is centered in rough opening. Cover screws with provided caps.



## HOW TO SURFACE MOUNT CABINET

If installing in combination with a middle mirror/shelf kit, please see “Center Mirror/Shelf Kit Installation” Directions that came with your center mirror prior to performing the steps below.

1. Establish precise height and draw a level horizontal line (Fig 6).

**IMPORTANT:** Detect medicine cabinet at precise height. Make sure there is at least 1" of clearance above any obstructions.

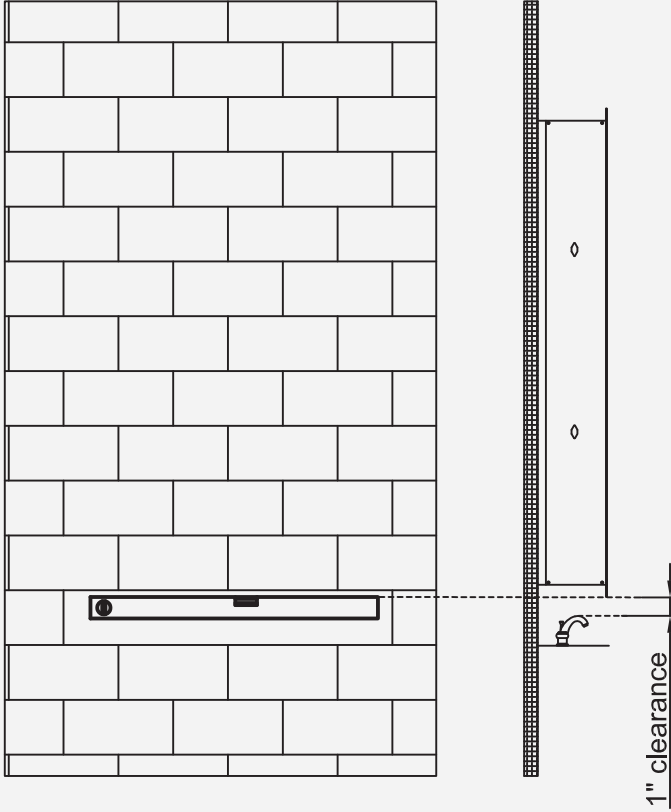

Fig 6

2. Place bottom of wall bracket on horizontal line and at correct position left to right and mark holes on wall (Fig 7).

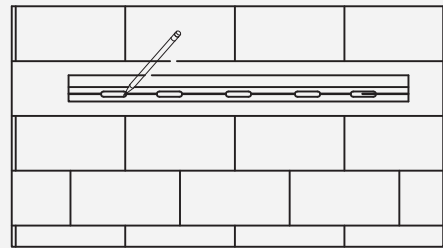
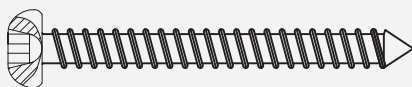

Fig 7

3. Drill 8 mm hole if required for wall anchor and place wall anchor in hole. Mount wall bracket with #10 x 1 1/2" screws. (Fig 8)



SCREW 1 1/2" (5)

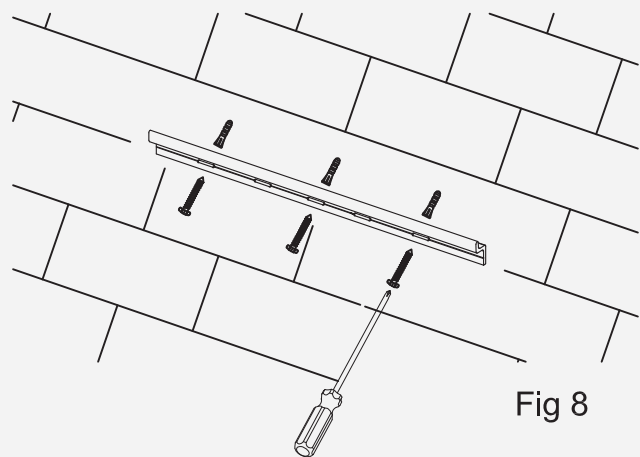

Fig 8

4. Insert surface mount z-clips 6 as shown (Fig 9 & 10).

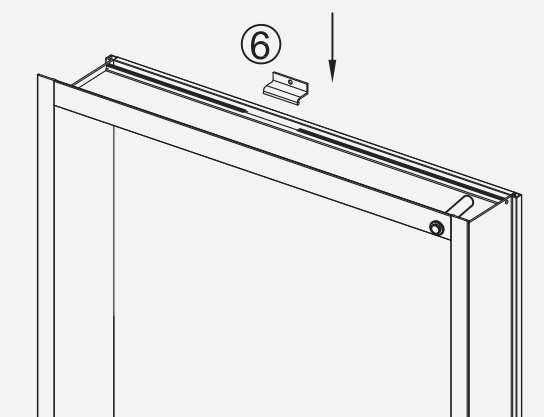

Fig 9

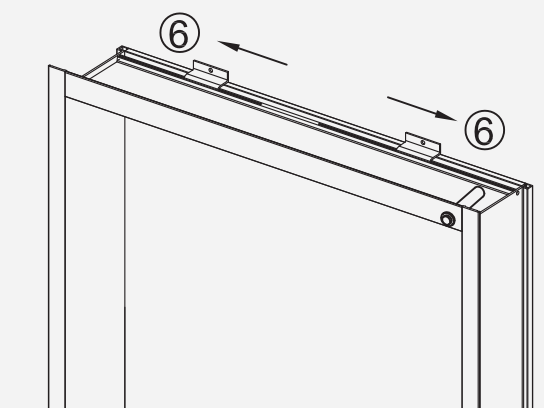

Fig 10

5. Place cabinet into wall bracket (Fig 11). Mark hole locations of z-clips (Fig 12). When determining location, it is recommended that at least one z-clip be located at a stud. Detach cabinet and drill 8mm hole if needed for anchor, and place in anchor in hole.

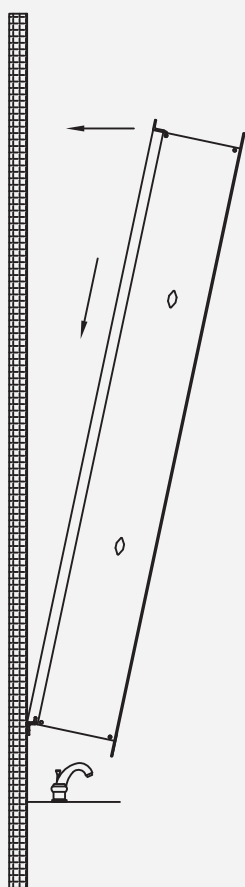

Fig 11

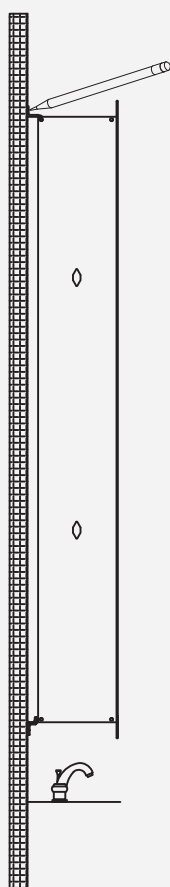

Fig 12

6. Remount the cabinet and connect with #10x 1 1/2" screws (Fig 13). Be careful not to damage or scrape the top flange.

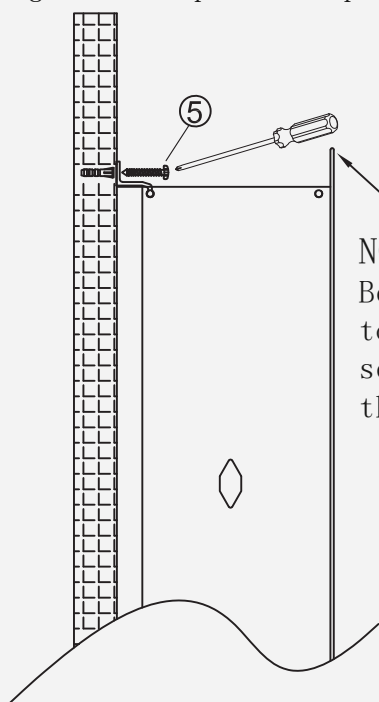
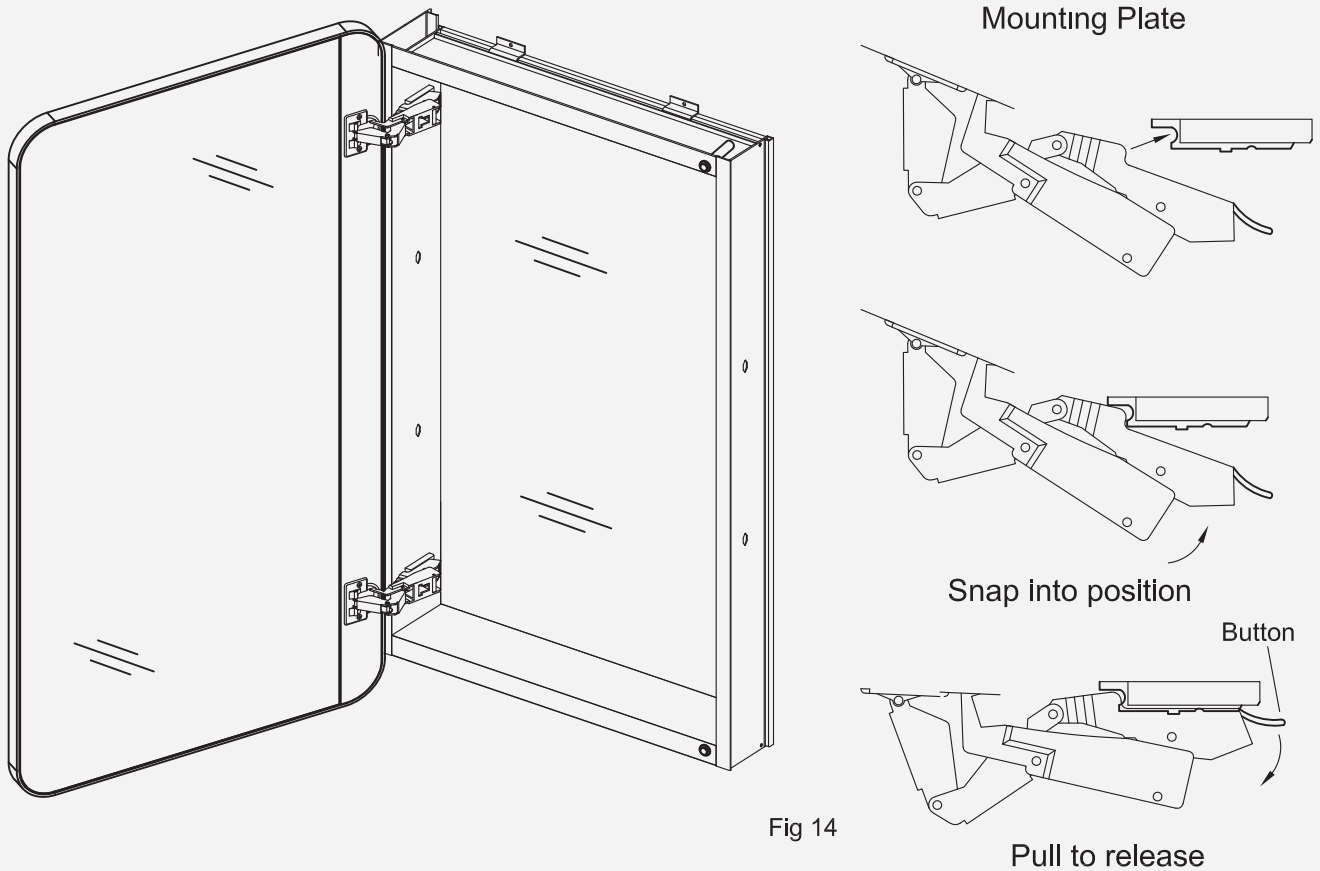

Fig 13

NOTE:  
Be careful not  
to damage or  
scratch  
the top flange.

## DOOR INSTALLATION

1. Remove the protective packaging from the door, being careful not to bump the edges of the mirror. Line up the hinges against the hinge mounting plates. Snap into position (Fig 14).



2. The door should "snap" locked when about 1" from being fully closed. The door should be placed evenly in relation to the cabinet.

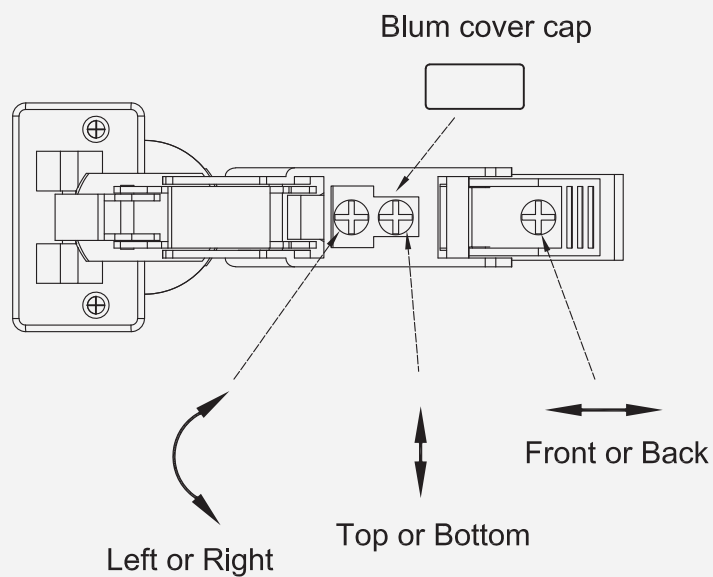

## ■ LIMIT CLIPS

Limit Clips 13 are provided should you need to reduce the opening swing of the cabinet door from 170 degrees to 130 degrees (see top view) This will eliminate the possibility of the door hitting a wall sconce or other decorative items.

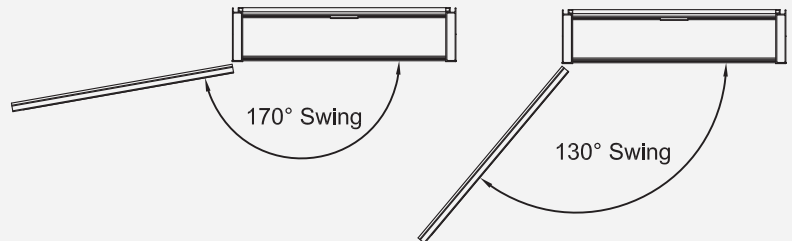
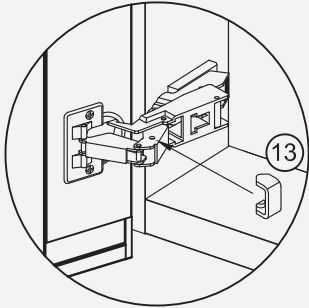

## ■ ADDITIONAL ITEM INSTALLATION

1. Insert clear shelf clip into appropriate hole location using 2 clips per shelf

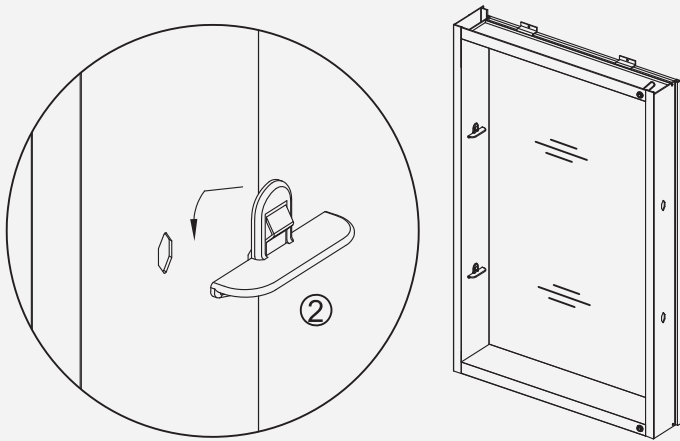

Fig 16

2. Place the glass shelf on top of the clear shelf clips, making sure the shelf is against the back of the cabinet. Press lightly to adhere the

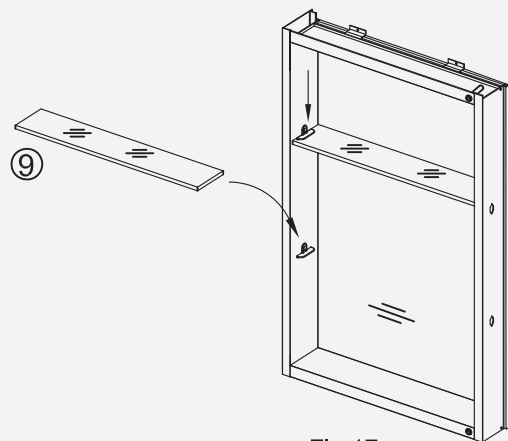

Fig 17

3. Fill the remaining holes with hole plugs (Fig 18). Fill the rest of the shelf clip holes with decorative covers (Fig 19).

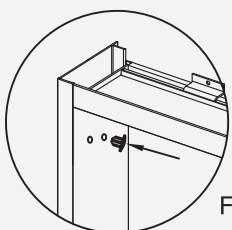

Fig 18

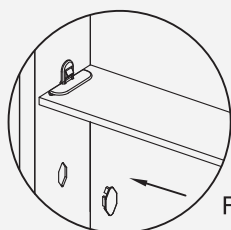
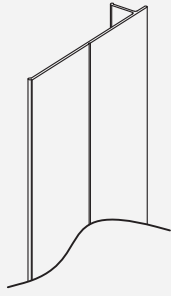
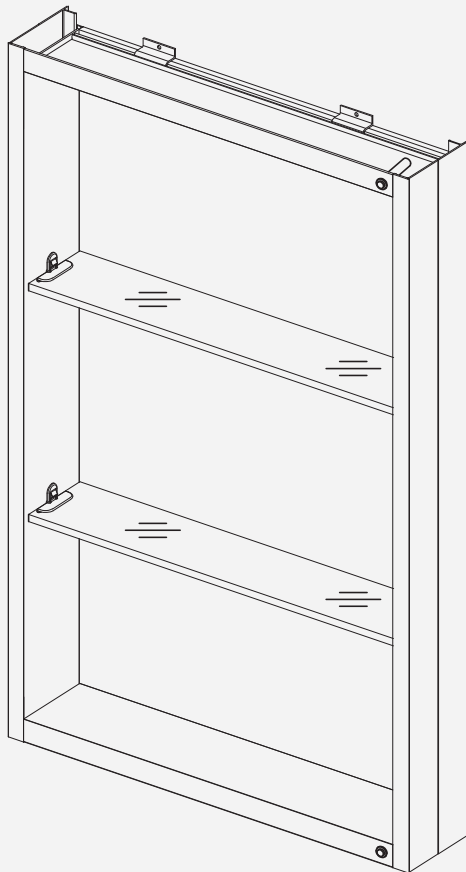
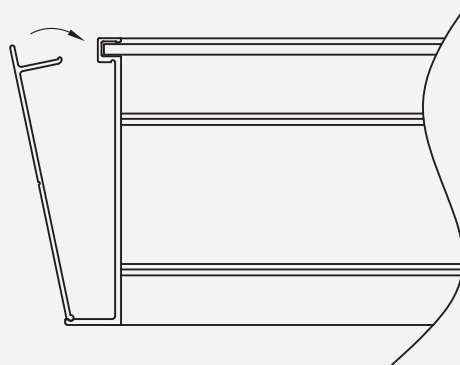
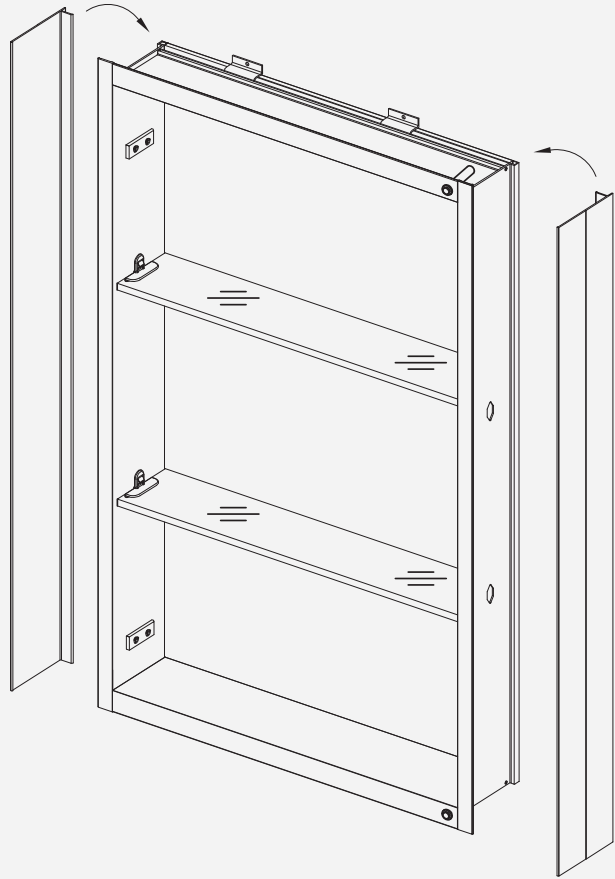

Fig 19

▪ INSTALL COVER PLATE:









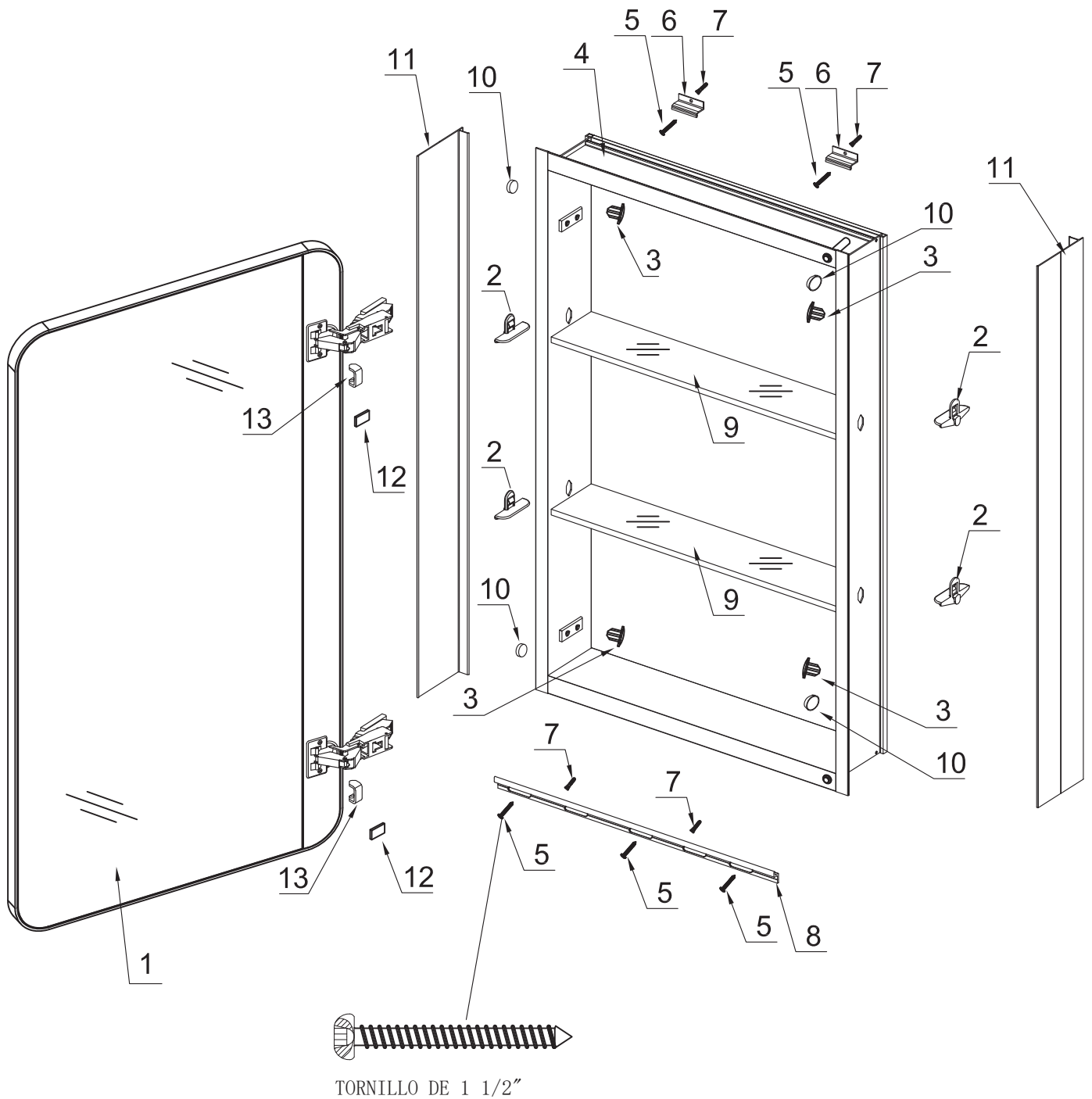

COVER PLATE (2 pcs)

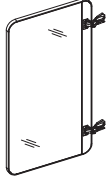
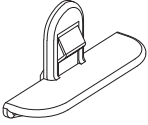

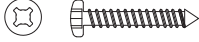
# Diagrama detallado de los componentes del espejo de aluminio

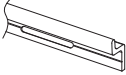
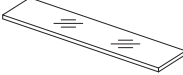

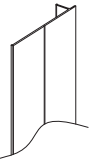
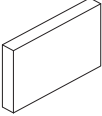

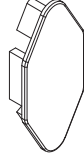

LISTA DE PIEZAS.

|   |   |   |   |   |
|---|---|---|---|---|
|  |  |  |  |  |
| TALADRO (1 pieza)   | GANCHO PARA ESTANTE<br>TRANSPARENTE (4 piezas)                                    | TAPÓN DE AGUJERO (10 piezas)  | GABINETE (1 pieza)  | TORNILLO #10-1 1/2 (5 piezas)   |
|  |  |  |   |  |
| GANCHO EN Z SUPERIOR<br>(2 piezas)  | TACO (5 piezas)   | SOPORTE DE MONTAJE (1 pieza)  | ESTANTE DE CRISTAL (2 piezas)   | TAPA PARA CUBRIR CABEZA<br>DE TORNILLO (5 piezas)                                   |
|  |  |  |  |   |
| PLACA DE CUBIERTA (2 piezas)  | TAPA DE CUBIERTA (2 piezas)   | CLIPS DE LÍMITE DE<br>130 GRADOS (2 piezas)                                       | TAPA DECORATIVA<br>( 0pieza / 4 piezas / 6 piezas )                                 |   |

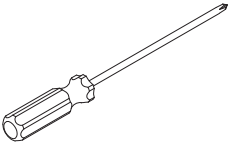
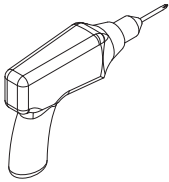
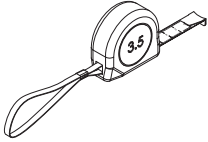
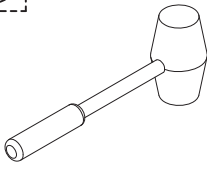
ADVERTENCIA: SE DEBEN USAR GAFAS DE SEGURIDAD SIEMPRE QUE SE TRABAJE CON UN GABINETE DE MEDICINA.

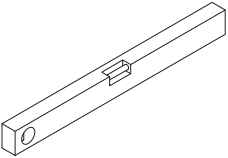
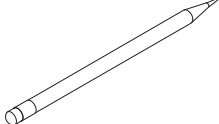
HERRAMIENTAS RECOMENDADAS:

|   |   |   |  |   |
|---|---|---|--|---|
|  |  |  |  |  |
| DESTORNILLADORES  | PERFORADORA   | CINTA MÉTRICA   | MARTILLO DE GOMA   | 5/16"<br>Brocas   |
|   |  |  |  |   |
| NIVEL   | LÁPIZ   | SAFETY GLASSES  |  |   |

▪ DETERMINACIÓN DE LA MEDICIÓN Y LA DIRECCIÓN:

| ALTURA         | ANCHO          | PROFUNDIDAD | TOLERANCIA   |
|----------------|----------------|-------------|--------------|
| <b>23 1/2"</b> | <b>14 1/2"</b> | <b>4"</b>   | <b>±1/8"</b> |
| <b>25 1/2"</b> | <b>19 1/2"</b> | <b>4"</b>   | <b>±1/8"</b> |

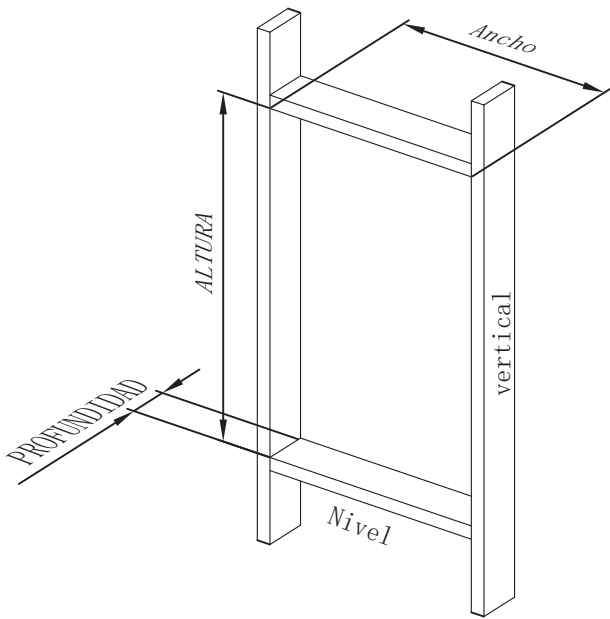
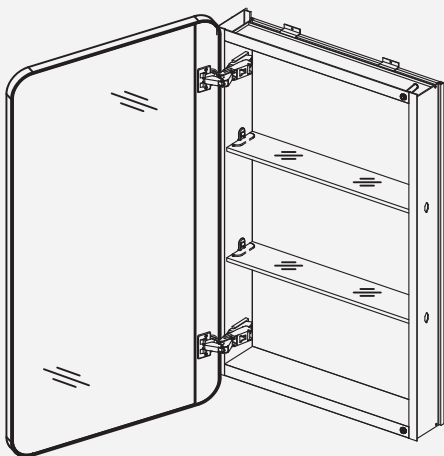

Fig 1

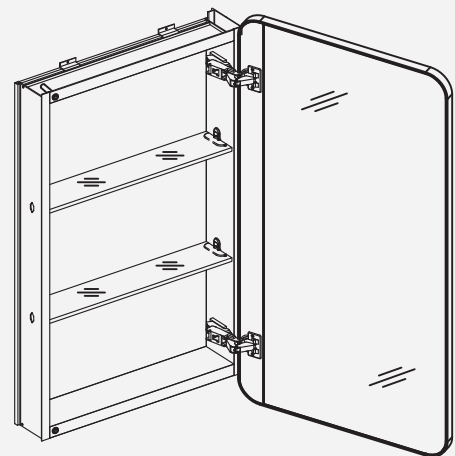

Fig 2

- En caso necesario, dé la vuelta al revés para obtener la instalación en la mano opuesta.



Instalación para la mano izquierda



Instalación para la mano derecha

## EMPOTRADO O SEMIENCASTRADO

Para paneles de yeso con un grosor superior a 10-12 mm, asegúrese de utilizar los anclajes específicos para paneles de yeso durante la instalación. Para paneles de yeso con un grosor inferior a 10-12 mm, asegúrese de instalar los soportes en los montantes.

1. Retire los paneles laterales del gabinete como se muestra en la figura.

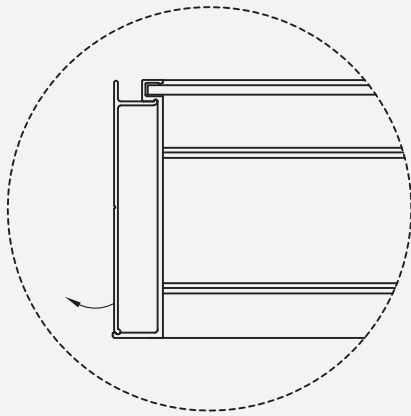

Vista superior

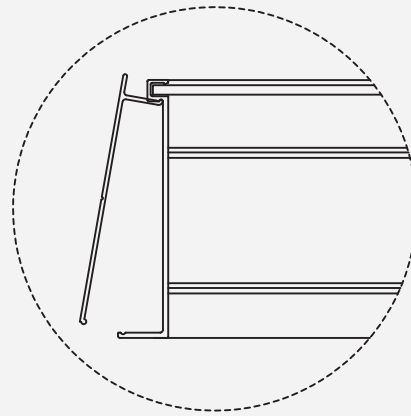

Vista superior

2. Asegúrese de que las bisagras estén en el lado correcto de la abertura para una operación con la mano izquierda o derecha. Coloque la caja del gabinete en la abertura bruta. Para instalaciones completamente empotradas, asegúrese de que el faldón del gabinete cubra la abertura bruta de manera uniforme alrededor (Figura 3). Para aplicaciones semiencastradas, los bordes del espejo deben estar alineados con la superficie de la pared (Figura 4). Use calces según sea necesario.

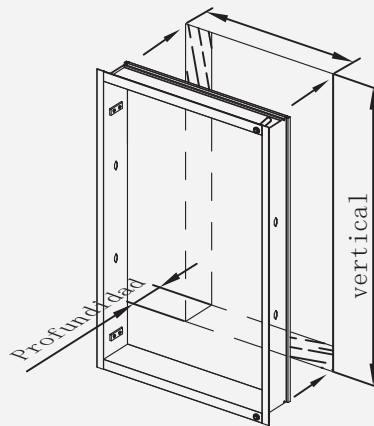

Fig 3

semiencastrado

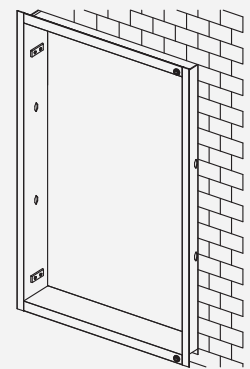

Fig 4

3. Inserte cuatro (4) tornillos X 1 1/2" en las cuatro ubicaciones proporcionadas para la instalación empotrada (Fig 5). Tenga cuidado de no apretar en exceso. Asegúrese de que el gabinete esté centrado en la abertura bruta. Suba los tornillos con las tapas proporcionadas.

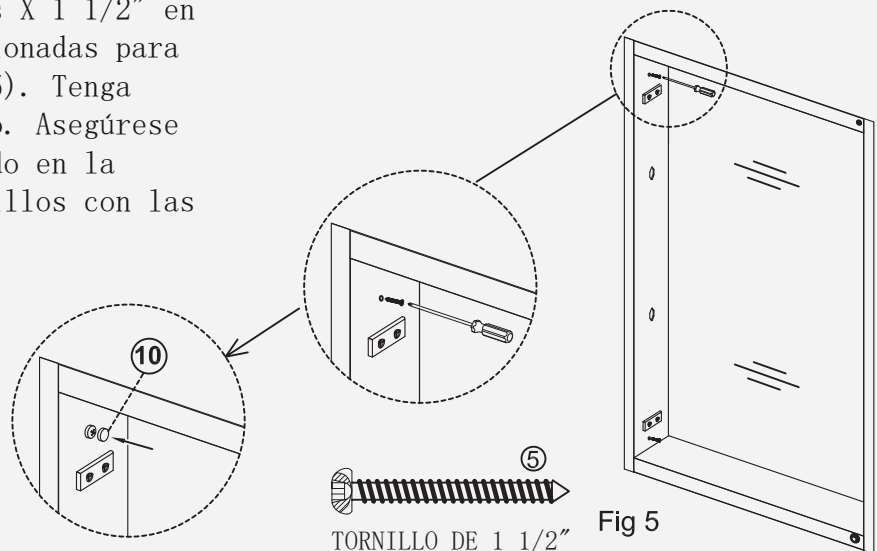

Fig 5

## CÓMO MONTAR EL GABINETE EN SUPERFICIE

Si está instalando en combinación con un kit de espejo/estante central, consulte las Instrucciones de 'Instalación del Kit de Espejo/Estante Central' que vinieron con su espejo central antes de realizar los pasos a continuación.

1. Establezca la altura precisa y dibuje una línea horizontal nivelada (Fig 6).

**IMPORTANTE:** Coloque el gabinete de medicina a la altura precisa. Asegúrese de que haya al menos 1" de espacio libre por encima de cualquier obstrucción.

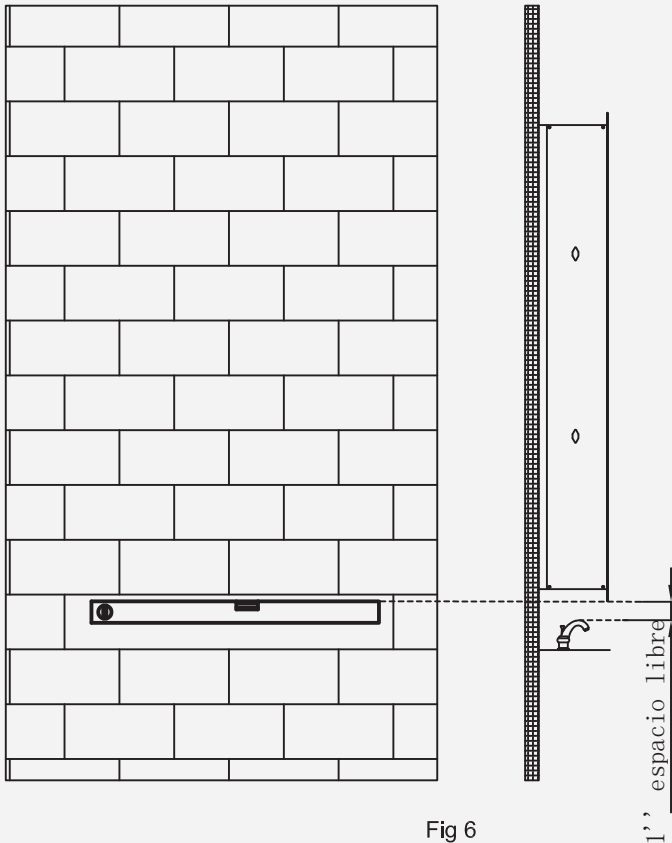

2. Coloque la parte inferior del soporte de pared en la línea horizontal y en la posición correcta de izquierda a derecha, y marque los agujeros en la pared (Fig 7).

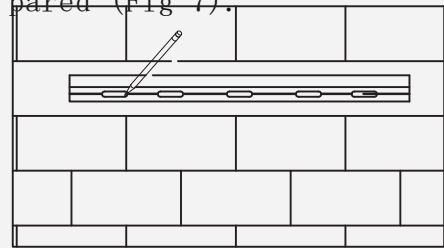

3. Taladre un agujero de 8 mm si es necesario para el anclaje de pared y coloque el anclaje de pared en el agujero. Monte el soporte de pared con tornillos

#10 x 1 1/2" (Fig 8).

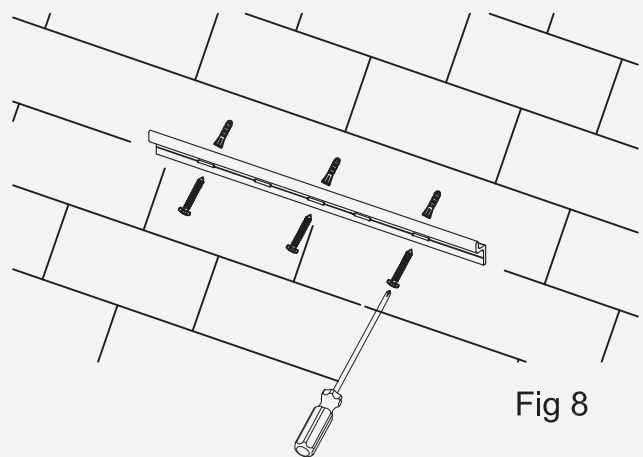
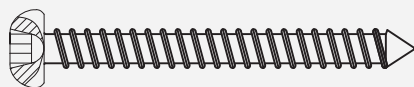

4. Inserte los clips Z 6 de montaje en superficie, como se muestra (Fig 9 y 10).

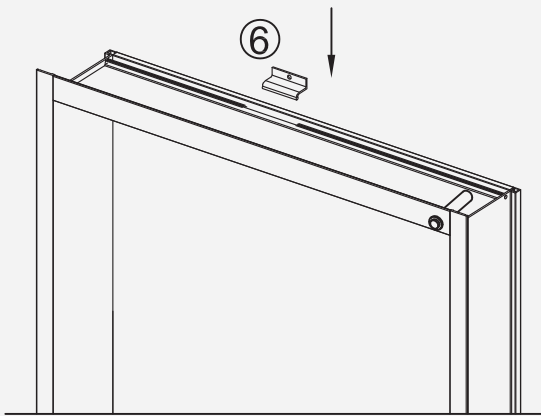

Fig 9

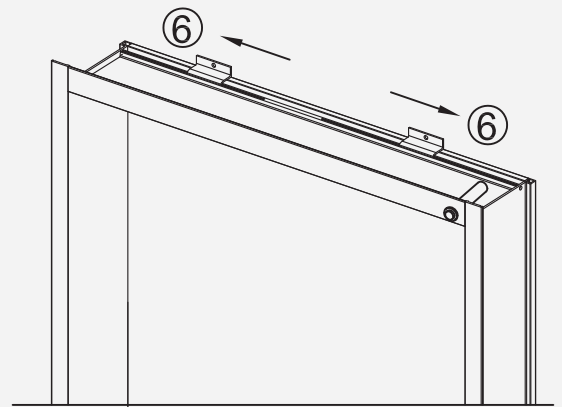

Fig 10

5. Coloque el gabinete en el soporte de pared (Fig 11). Marque las ubicaciones de los agujeros de los clips Z (Figura 12). Al determinar la ubicación, se recomienda que al menos un clip Z esté ubicado en un montante. Retire el gabinete y taladre un agujero de 8 mm si es necesario para el anclaje, y colóquelo en el agujero.

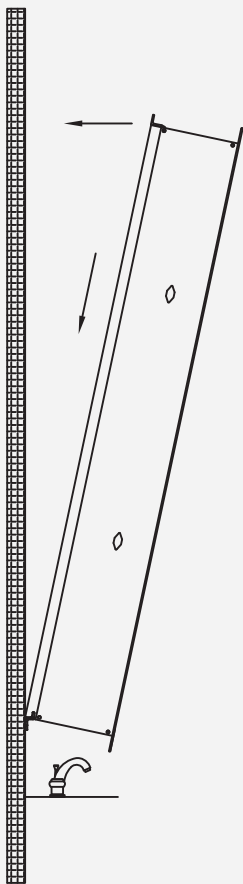

Fig 11

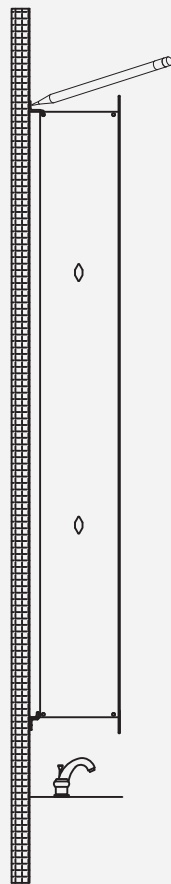

Fig 12

6. Vuelva a montar el gabinete y conéctelo con tornillos #10x 1 1/2" (Fig 13). Tenga cuidado de no dañar ni raspar el faldón superior.

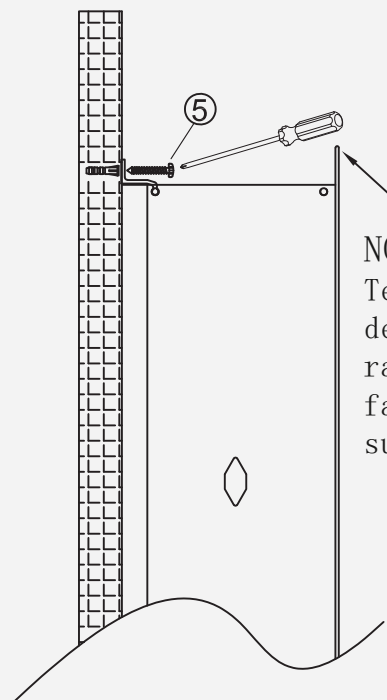
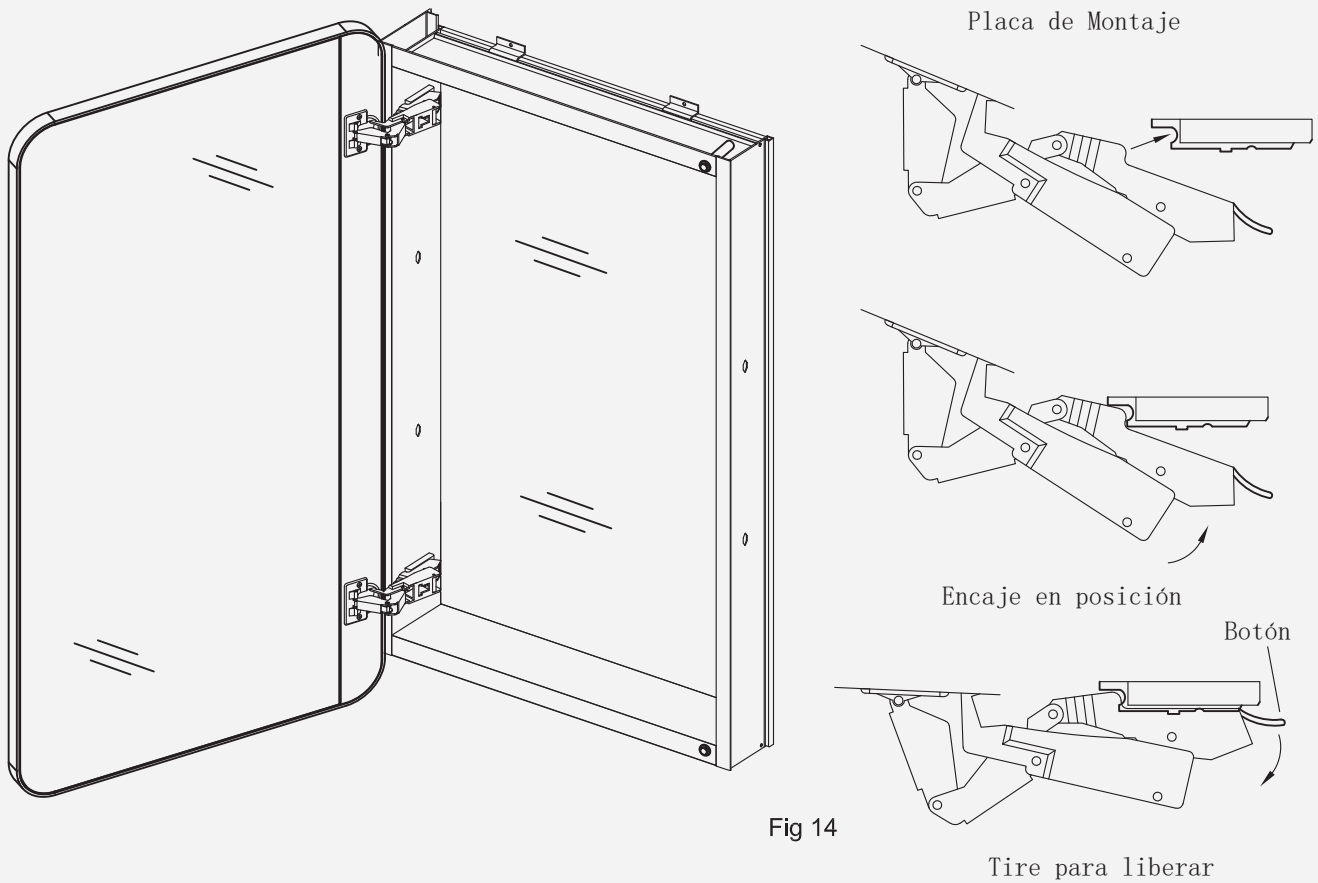

Fig 13

NOTA:  
Tenga cuidado  
de no dañar ni  
rayar el  
faldón  
superior.

## INSTALACIÓN DE LA PUERTA

1. Retire el embalaje protector de la puerta, teniendo cuidado de no golpear los bordes del espejo. Alinee las bisagras con las placas de montaje de bisagras. Encaje en posición. (Fig. 14).



2. La puerta debe 'encajar' cuando esté a aproximadamente 1 pulgada de cerrarse por completo. La puerta debe colocarse de manera uniforme en relación con el gabinete.

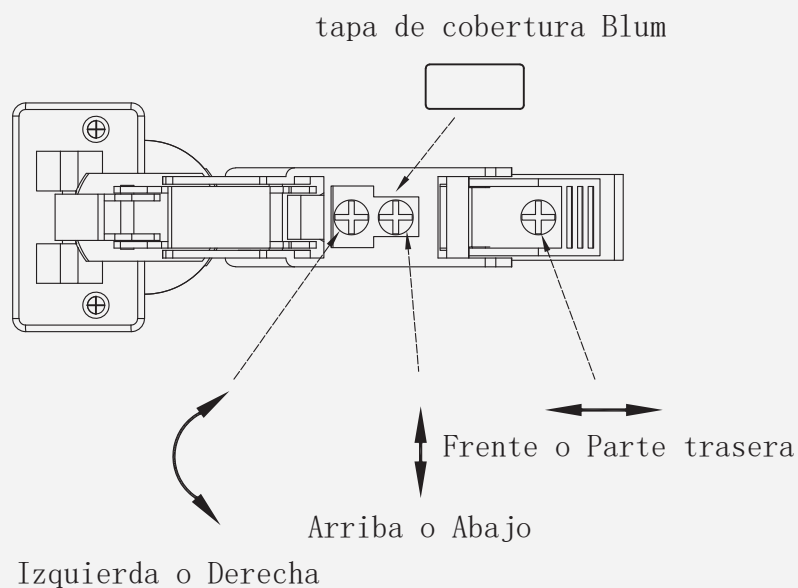

## CLIPS DE LÍMITE

Se proporcionan clips ⑬ de límite en caso de que necesite reducir la apertura de la puerta del gabinete de 170 grados a 130 grados (consulte la vista superior). Esto eliminará la posibilidad de que la puerta golpee un aplique de pared u otros

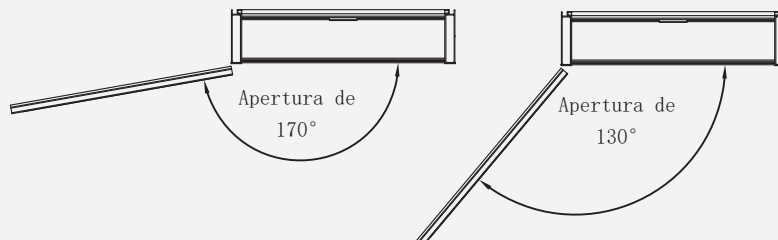
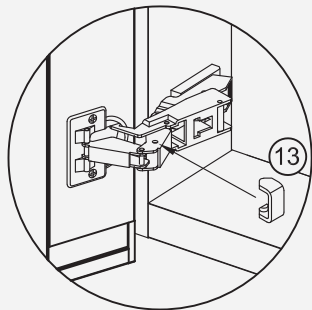

## INSTALACIÓN DE ARTÍCULO ADICIONAL

1. Inserte el clip transparente del estante en la ubicación del agujero correspondiente, utilizando 2 clips por estante (Fig 16).

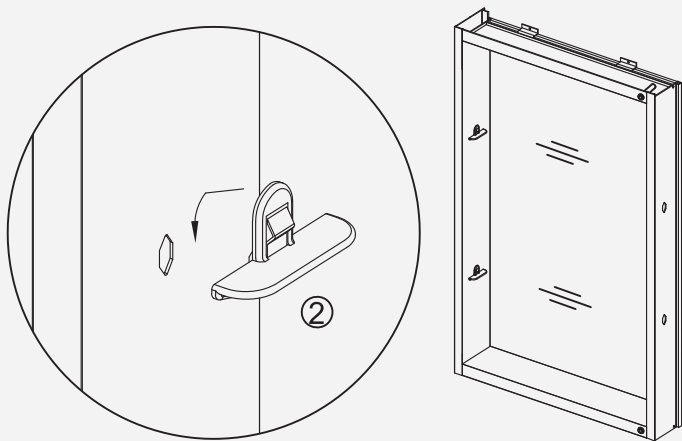

Fig 16

3. Complete los agujeros restantes con tapones de agujeros (Fig 18). Llene los demás agujeros de los clips de estante con tapas decorativas (Fig

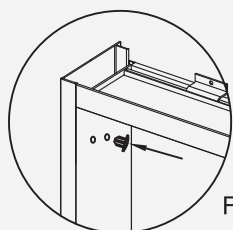

Fig 18

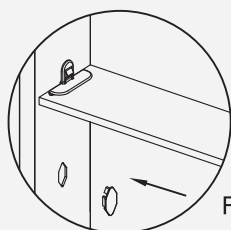

Fig 19

2. Coloque el estante de vidrio en la parte superior de los clips transparentes del estante, asegurándose de que el estante esté contra la parte posterior del gabinete. Presione ligeramente para adherir la pegatina del clip del

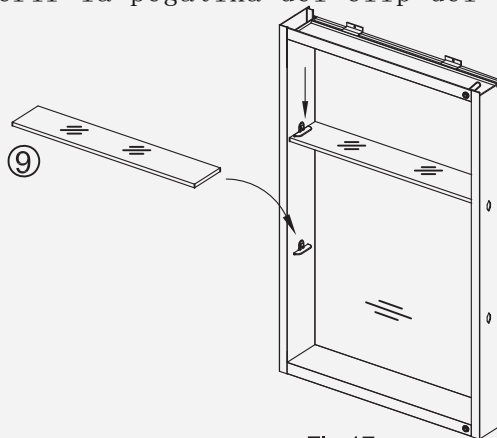
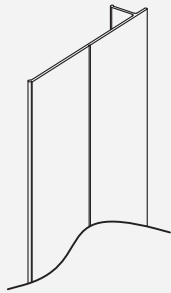

Fig 17

■ INSTALAR LA PLACA DE CUBIERTA :



PLACA DE CUBIERTA (2 piezas)

