

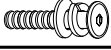



ASSEMBLY INSTRUCTIONS

IMPORTANT NOTE :

- * PLACE ALL WOODEN PARTS ON A CLEAN AND SMOOTH SURFACE SUCH AS A RUG OR CARPET TO AVOID THE PARTS FROM BEING SCRATCHED.
- * BEFORE YOU BEGIN, KINDLY FOLLOW THE ASSEMBLY INSTRUCTIONS STEP BY STEP.
- * DO NOT TIGHTEN ALL SCREWS UNTIL THE CHAIR IS FULLY SET-UP.

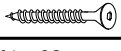
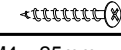
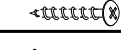
| HARDWARE LIST | | | PART LIST | | |
|---------------|---------------------------------------------------------------------------------------------------------------------------|-------|-----------|----------------------|------|
| A | JCBC M6 x 25mm + S/W M6 + F/W M6 x 13mm  | 4PCS | 1 | LEG RIGHT | 1PC |
| | | | 2 | LEG LEFT | 1PC |
| B | JCBC M6 x 55mm + S/W M6 + F/W M6 x 13mm  | 4PCS | 3 | TOP REST | 1PC |
| | | | 4 | CHAIR SEAT | 1PC |
| C | JCBC W SCREW M7 x 40mm  | 1PC | 5 | FRONT STRETCHER | 1PC |
| D | PH CB SCREW M4 x 32mm  | 2PCS | 6 | CENTER STRETCHER | 1PC |
| | | | 7 | CORNER BLOCK (LONG) | 2PCS |
| E | PH CB SCREW M4 x 25mm  | 17PCS | 8 | CORNER BLOCK (SHORT) | 2PCS |
| F | ALLEN KEY M4 (BALL SHAPE)  | 1PC | | | |
| G | PROTECTIVE DISC 22MM  | 4PCS | | | |

CAUTIONS :

(1) **DO NOT FULLY-TIGHTEN THE NUT OR NUT BOLTS INITIALLY UNTIL ALL NUTS OR BOLT IS READY ASSEMBLED.**

(TO AVOID CAUSING DAMAGES TO THE THREAD, DO NOT OVER-TIGHTEN THE NUTS OR BOLTS.)

(2) **KEEP ALL HARDWARE PART OUT OF REACH OF CHILDREN.**

STEP 1

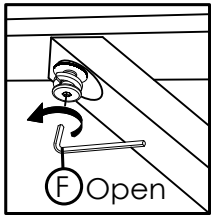

BEFORE ASSEMBLY PLEASE OPEN THE CENTER STRETCHER.

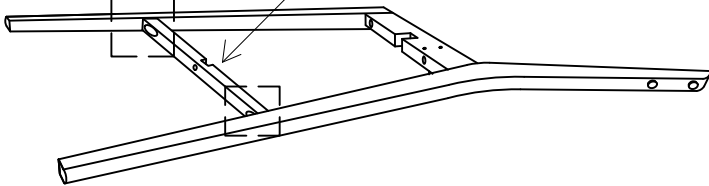

STEP 2

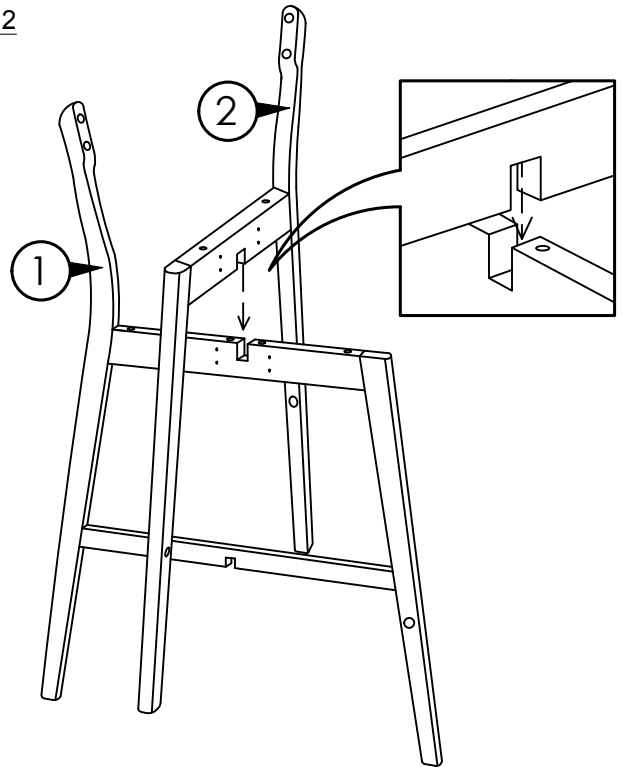

STEP 3

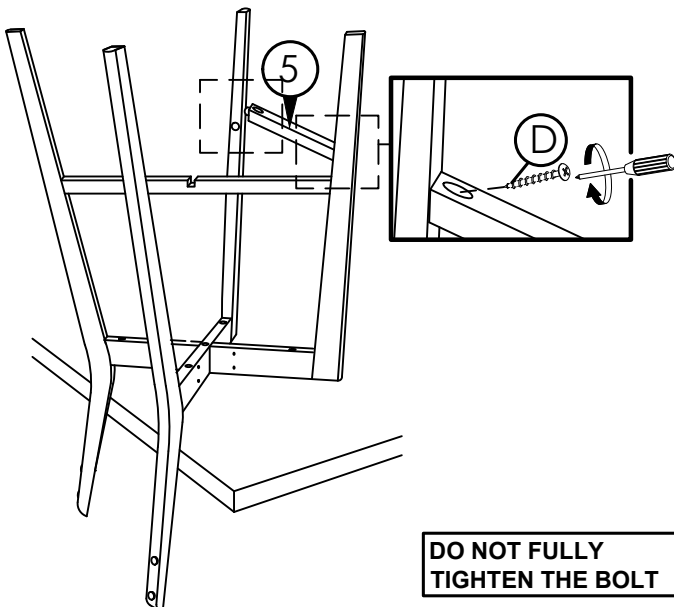

DO NOT FULLY TIGHTEN THE BOLT

STEP 4

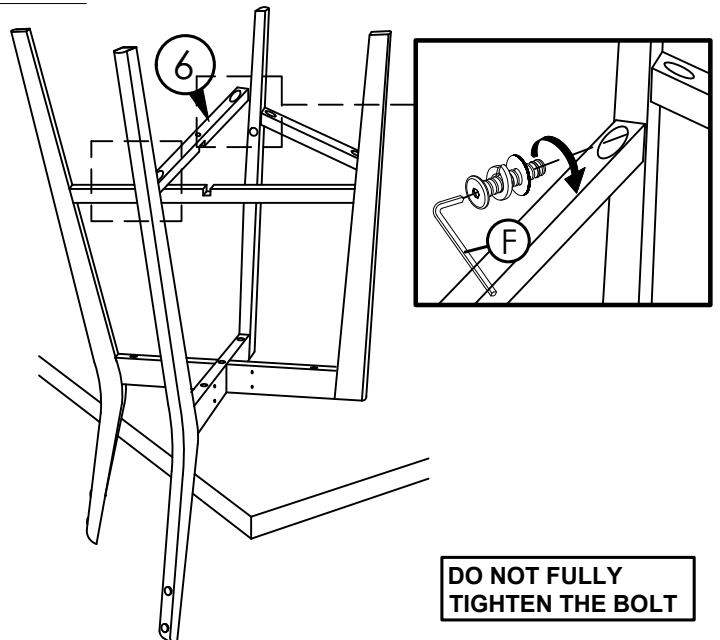

DO NOT FULLY TIGHTEN THE BOLT

ASSEMBLY INSTRUCTIONS

STEP 5

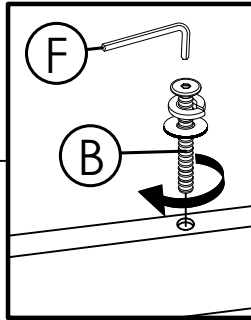
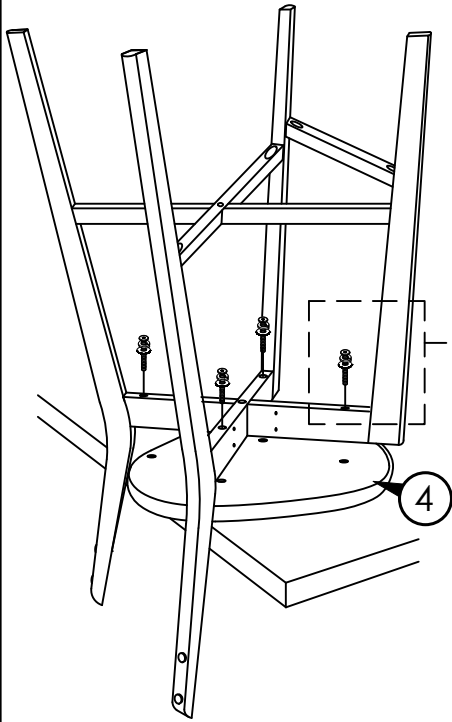

**DO NOT FULLY
TIGHTEN THE BOLT**

STEP 6

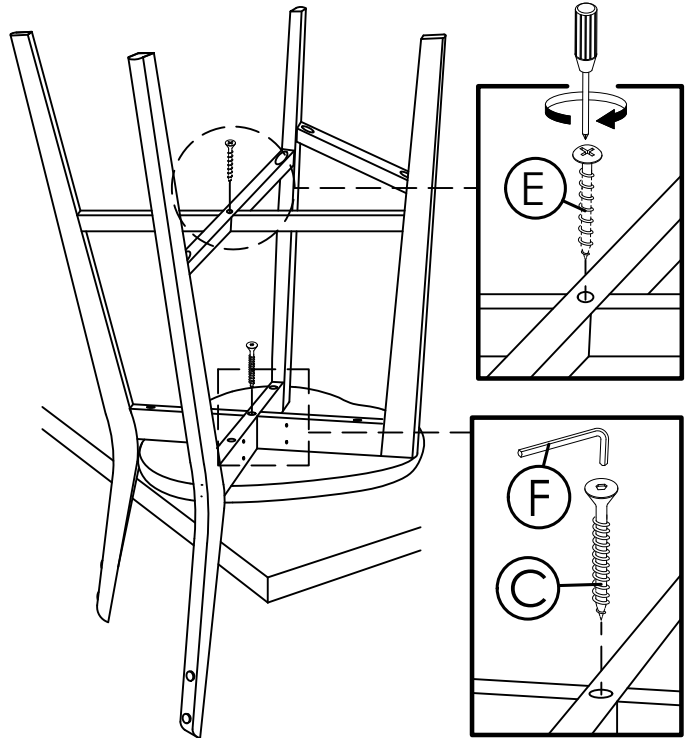

STEP 7

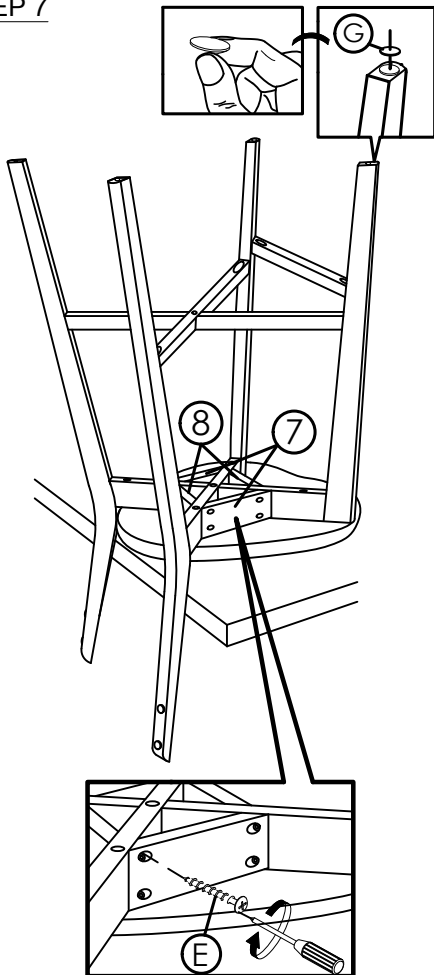

DO NOT FULLY TIGHTEN THE SCREW

STEP 8

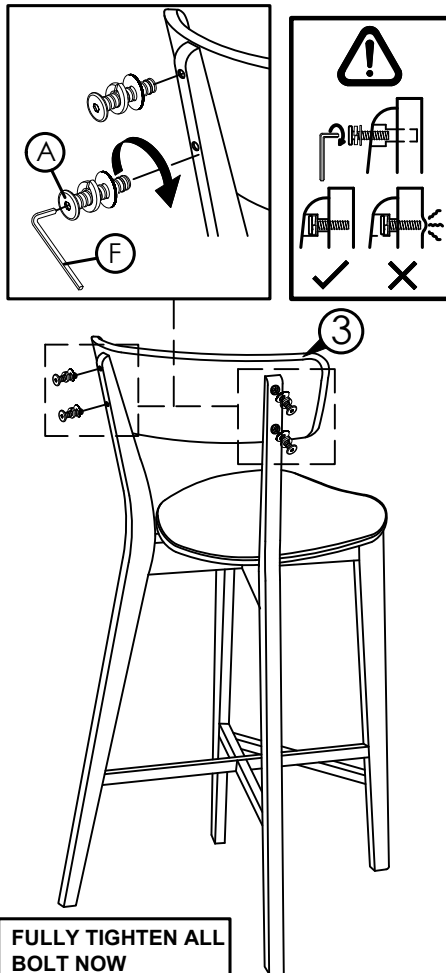

**FULLY TIGHTEN ALL
BOLT NOW**

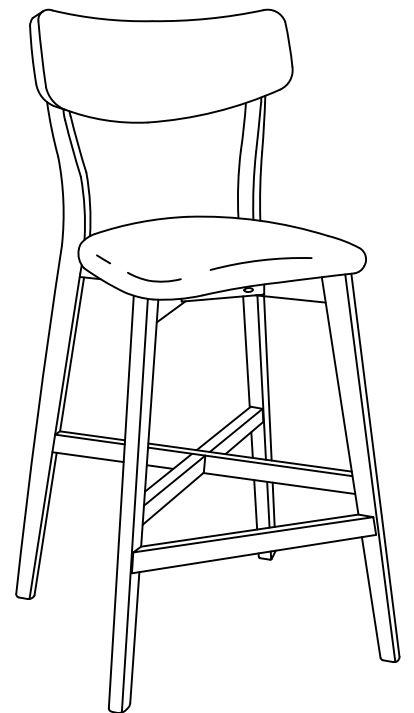

**COMPLETED
BARSTOOL ASSEMBLY.**