

# Assembly Instructions

## Option A

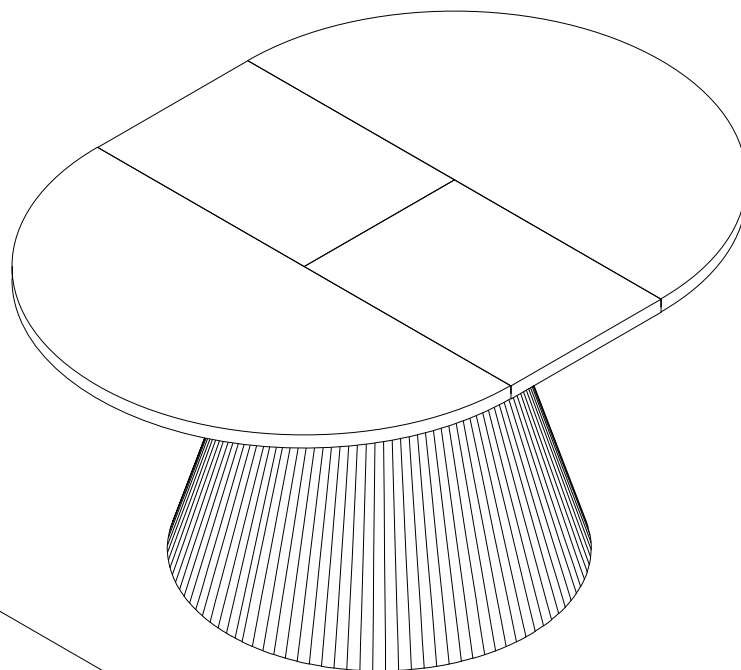

## Option B

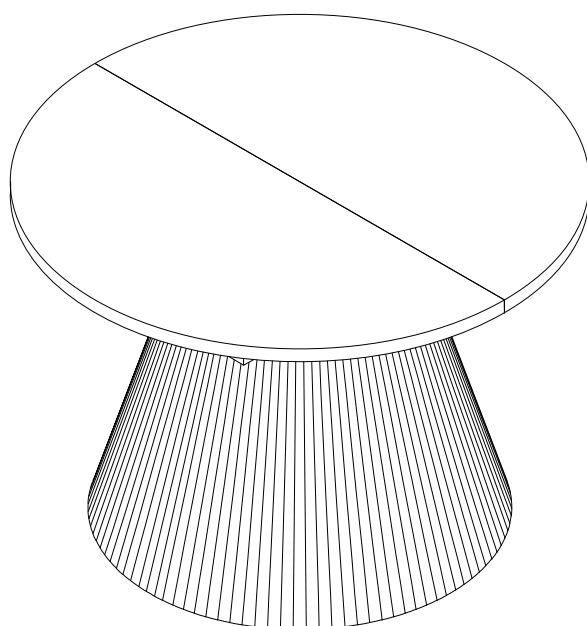

# Before Assembly

## Tips Before Your Start:

- Remove all wrapping material, including staples & packing straps before you start to assemble.
- DO NOT tighten all screws and bolts until the assembly is completely assembled.
- Keep all hardware parts out of reach of children.

## QUICKFIT

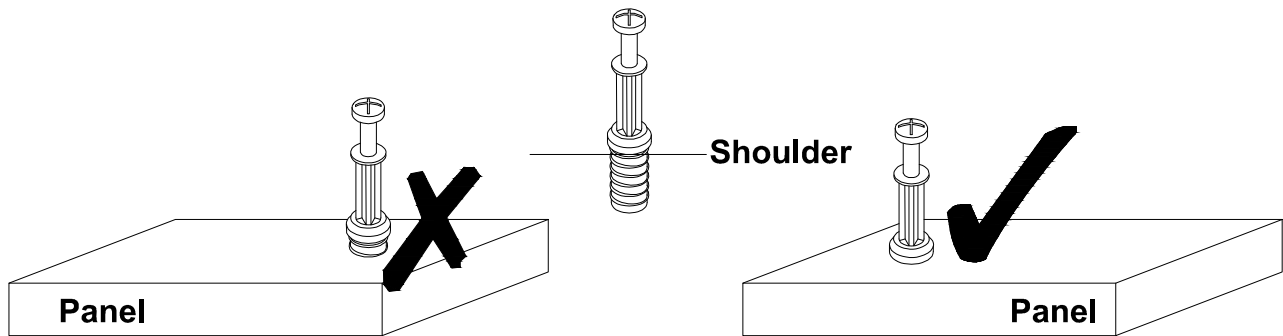

Tighten quickfit until shoulder is flush with panel. Do not overtighten or undertighten.

## CAM LOCK

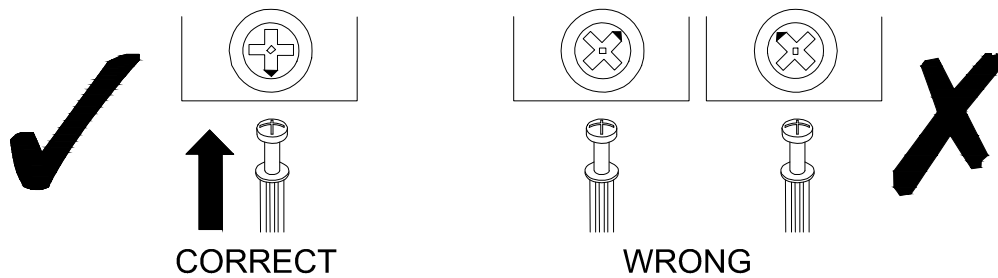

When fitting a cam lock, ensure the starting position is correct before inserting the connecting QUI CKFIT





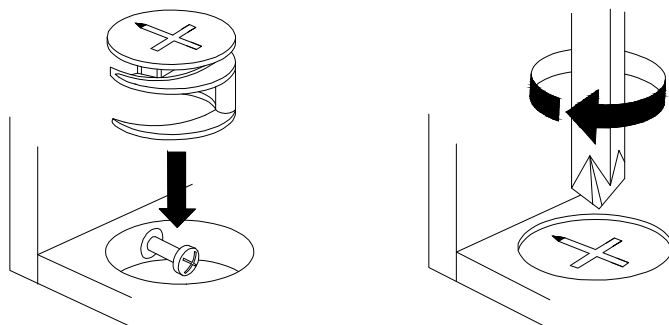

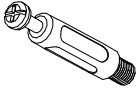

Quickfit head should be in the centre of the cam lock when the two panels are joined.

Cam lock should be inserted before quickfit.

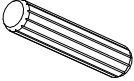
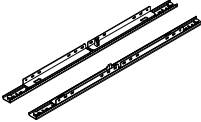

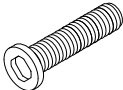
Turn cam lock clockwise to tighten.

# Part List

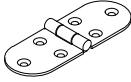
<p><b>No. A</b> Quantity:10 Pcs Cam Lock Dowel 8*28mm</p> 	<p><b>No. B</b> Quantity:10 Pcs Cam φ15</p> 	<p><b>No. C</b> Quantity:10 Pcs Sticker Ø20</p> 	<p><b>No. D</b> Quantity:14 Pcs Dowel 8*30mm</p> 
<p><b>No. E</b> Quantity:1 Sets Stretch hardware</p> 	<p><b>No. F</b> Quantity:40 Pcs Screw M3.5*14mm</p> 	<p><b>No. G</b> Quantity:4 Pcs Screw M6*30mm</p> 	<p><b>No. H</b> Quantity:32 Pcs Screw M6*40mm</p> 
<p><b>No. I</b> Quantity:8 Pcs Slip Mat Ø20</p> 	<p><b>No. J</b> Quantity:1 Pcs Allen Key 4#</p> 	<p><b>No. K</b> Quantity:2 Pcs Hinge 84*30*6mm</p> 	

# Product structure

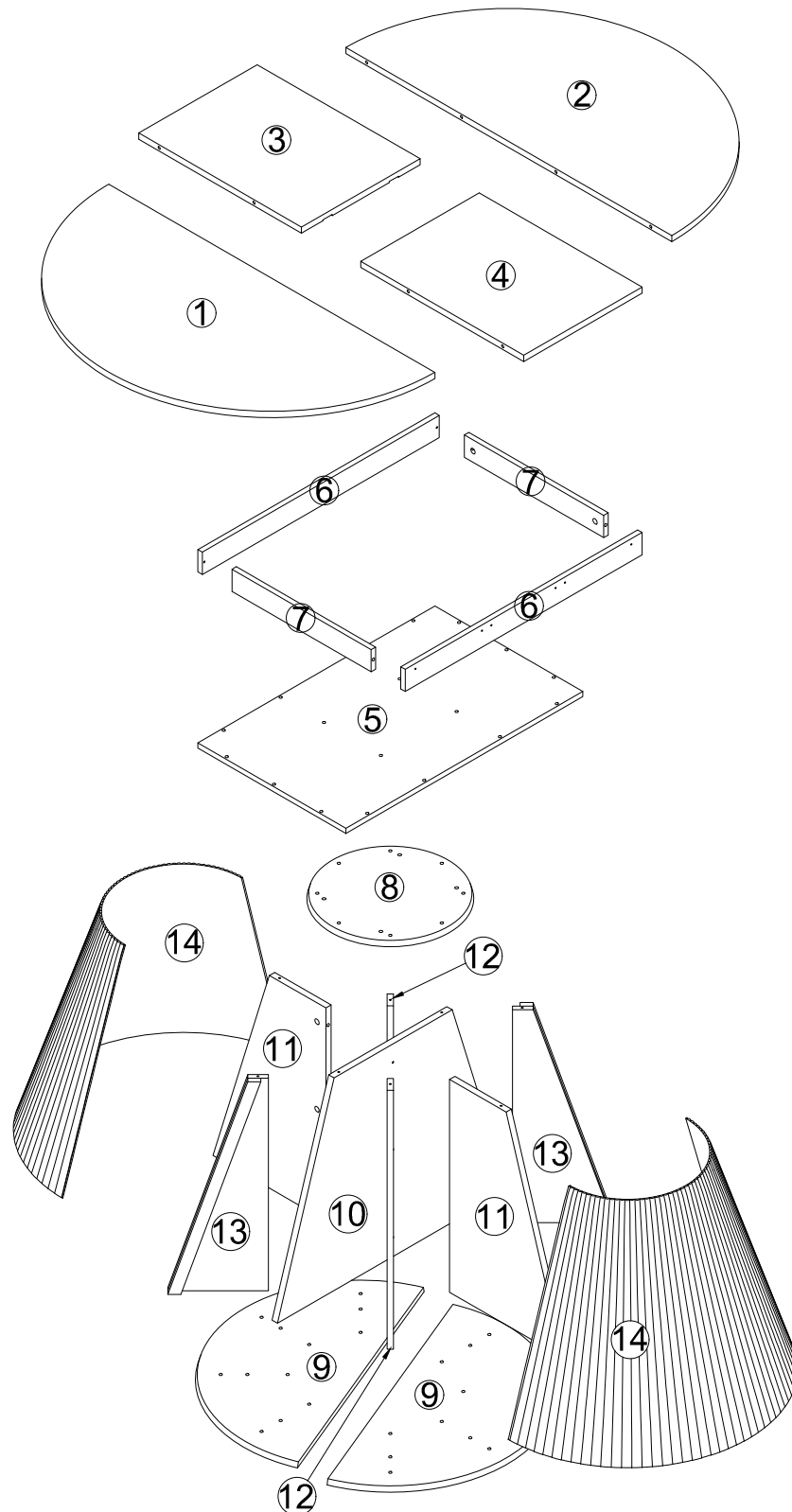

# STEP 1

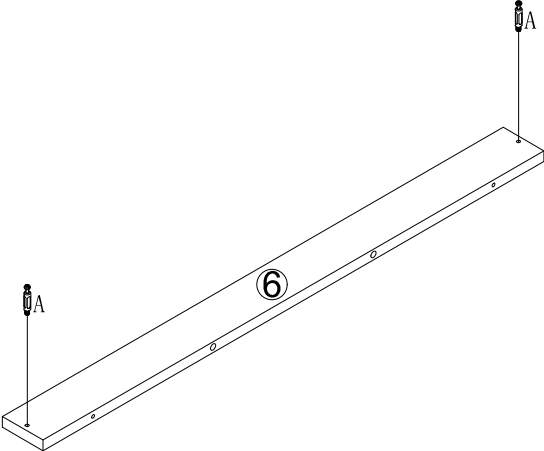

No. A  
Quantity: 4 Pcs  
8\*28 mm



**×2**

# STEP 2

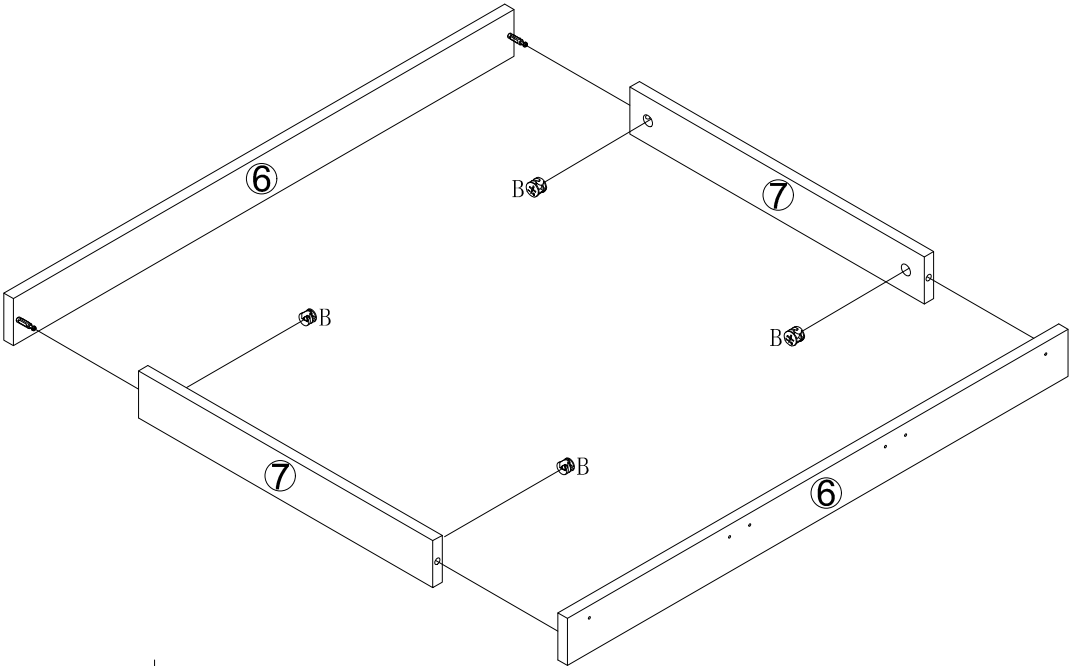

No. B  
Quantity: 4 Pcs  
Ø15



# STEP 3

No. D  
Quantity: 6 Pcs  
8\*30mm

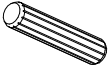

No. H  
Quantity: 8 Pcs  
M6\*40mm



No. J  
Quantity: 1 Pcs  
4#

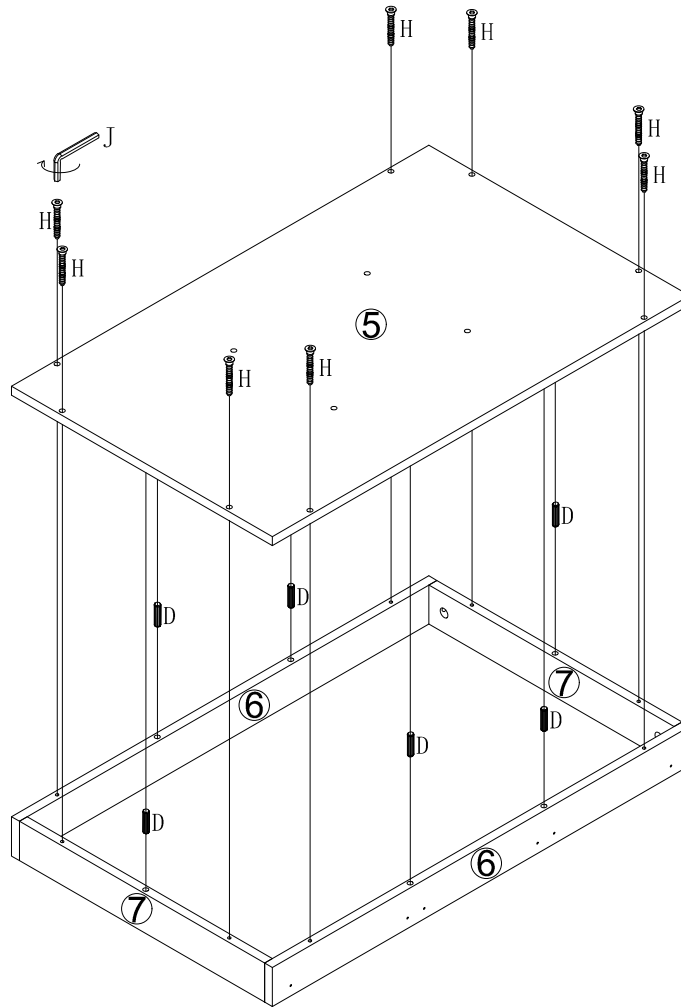

# STEP 4

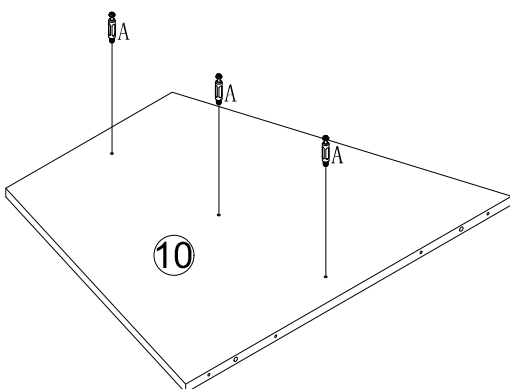

Flip to the other side.

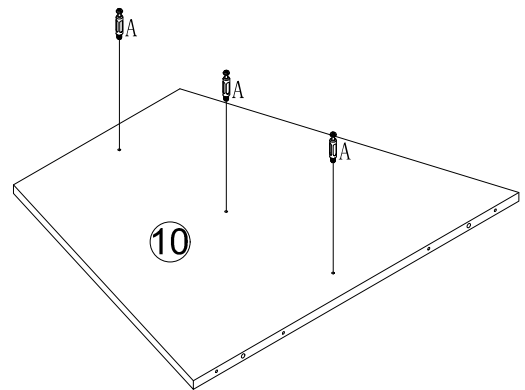

No. A  
Quantity: 6 Pcs  
8\*28 mm



# STEP 5

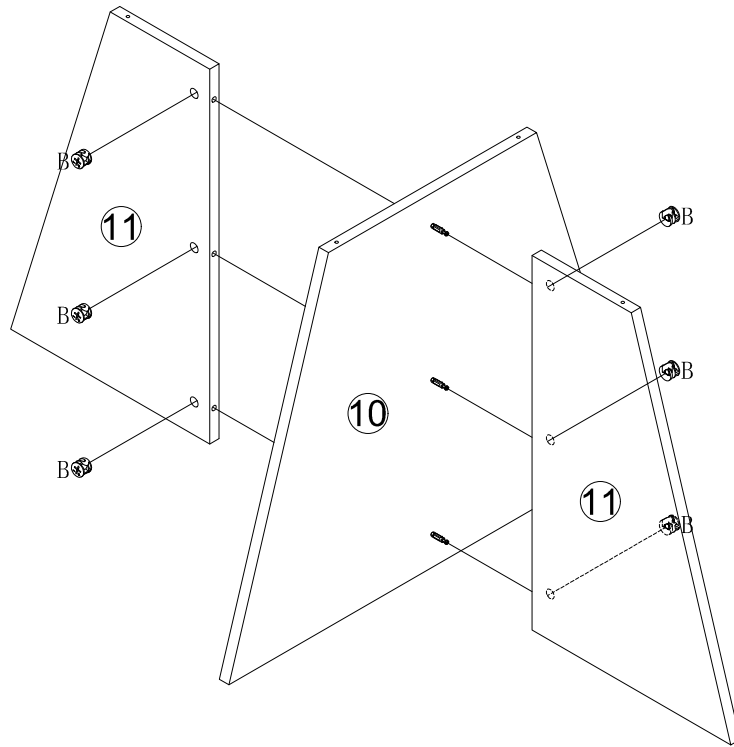

No. B  
Quantity: 6 Pcs  
Ø15



# STEP 6

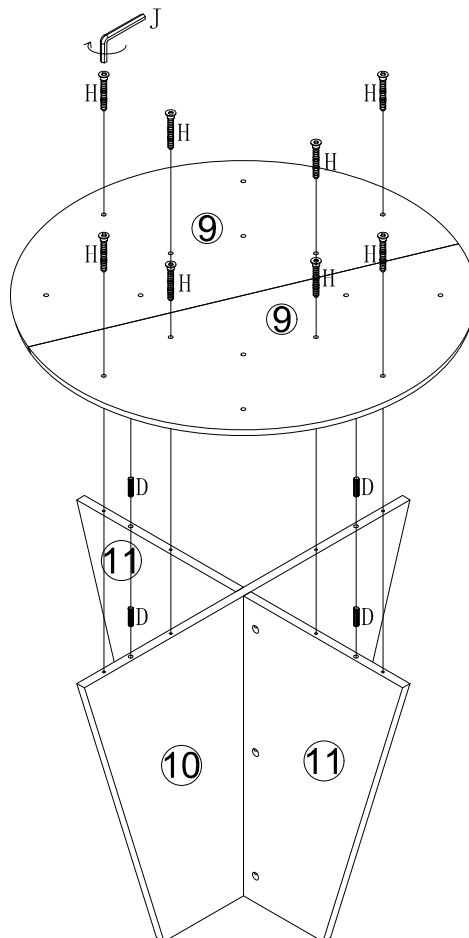

No. D  
Quantity: 4 Pcs  
8\*30mm

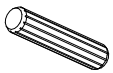

No. H  
Quantity: 8 Pcs  
M6\*40mm



No. J  
Quantity: 1 Pcs  
4#



## STEP 7

No. D  
Quantity: 4 Pcs  
8\*30mm

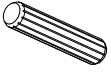

No. H  
Quantity: 8 Pcs  
M6\*40mm



No. J  
Quantity: 1 Pcs  
4#

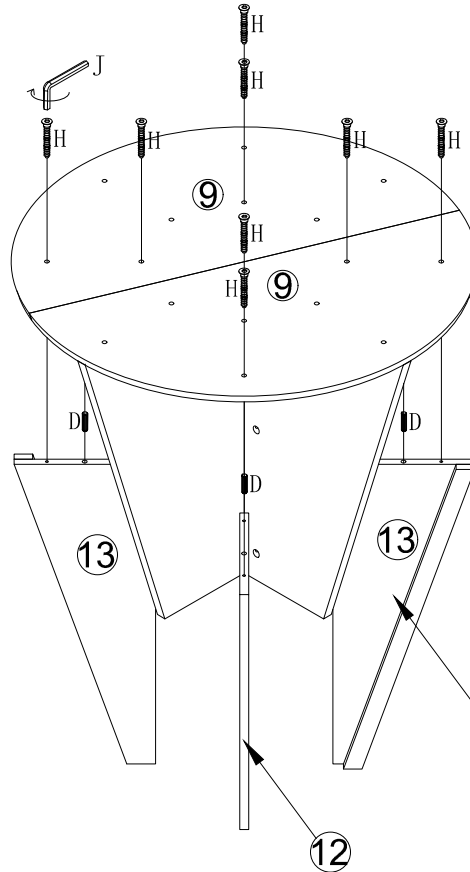

Please lift the No.9 plate slightly, and place the No.12 and No.13 components into position, then tighten the screws.

Please note that when assembling, distinguish the numbers, the two number 13 boards should be on opposite sides.

## STEP 8

No. I  
Quantity: 8 Pcs  
Ø20

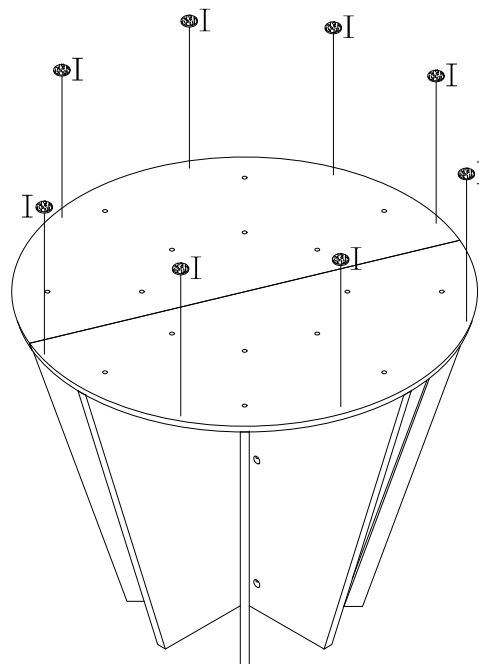

## STEP 9

No. H  
Quantity: 8 Pcs  
M6\*40mm



No. J  
Quantity: 1 Pcs  
4#

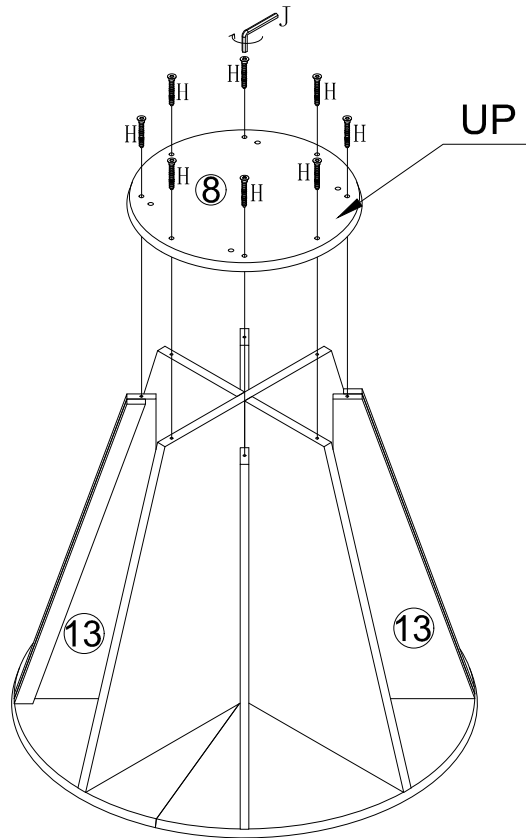

## STEP 10

Please note that when pasting the No.14 board, the interface must be pasted in the middle position of the No.13 board to ensure assembly.

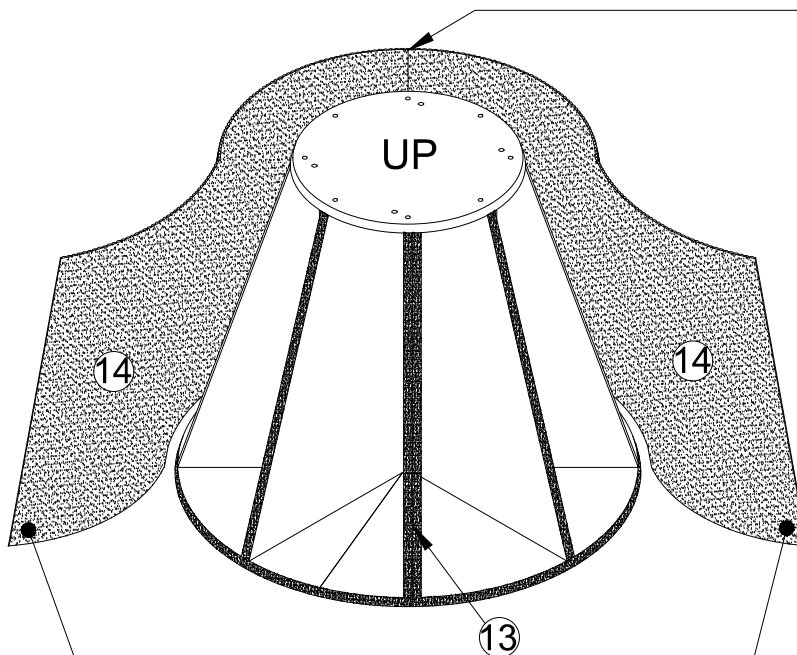

Note: The back is pasted with black felt cloth, which can be directly pasted on the board, pay attention to paste parallel.

# STEP 11

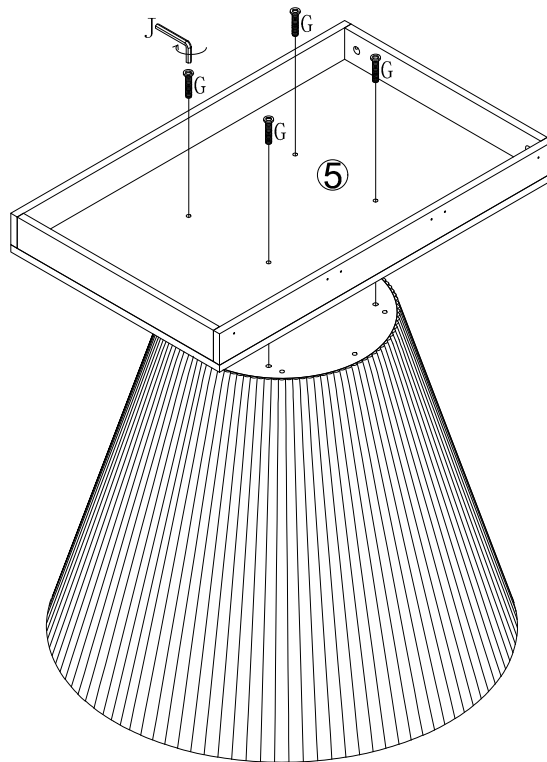

No. G  
Quantity: 4 Pcs  
M6\*30mm

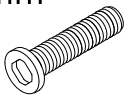

No. J  
Quantity: 1 Pcs  
4#



# STEP 12

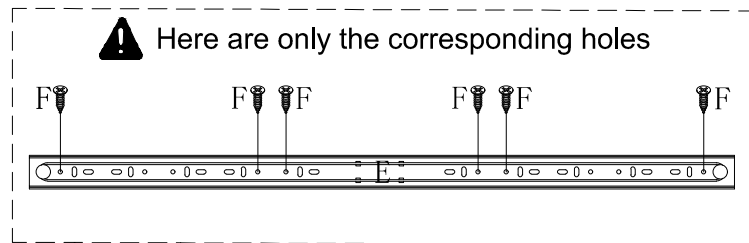

No. E  
Quantity: 1 Sets

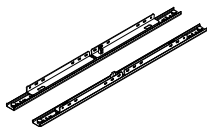

No. F  
Quantity: 12 Pcs  
M3.5\*14mm

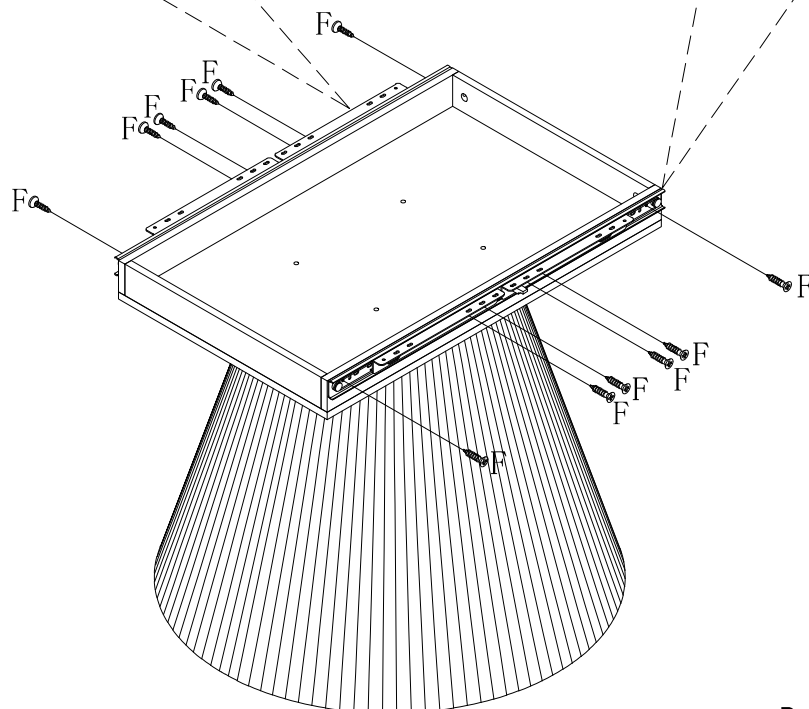

# STEP 13

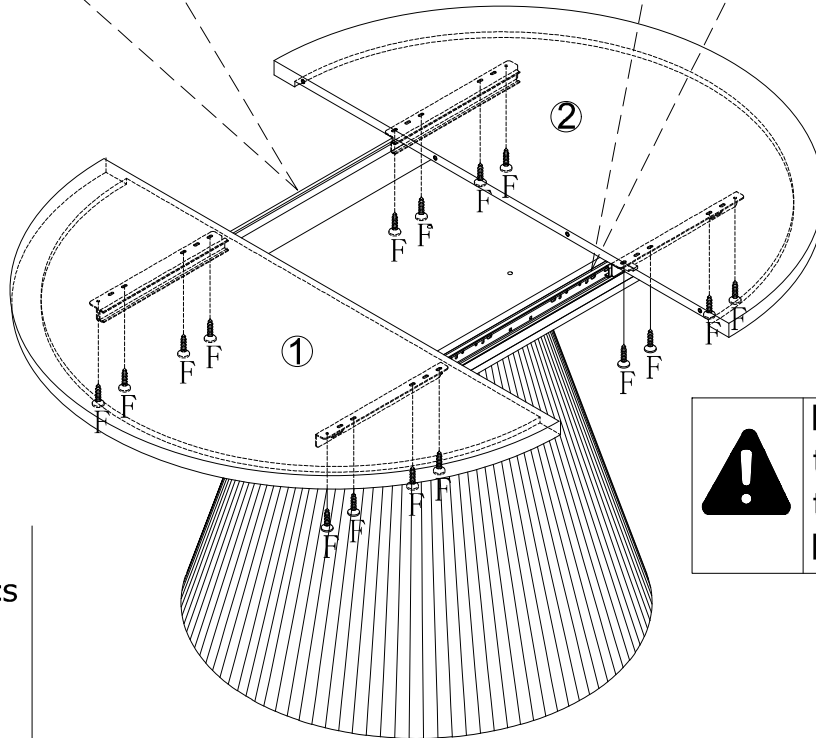
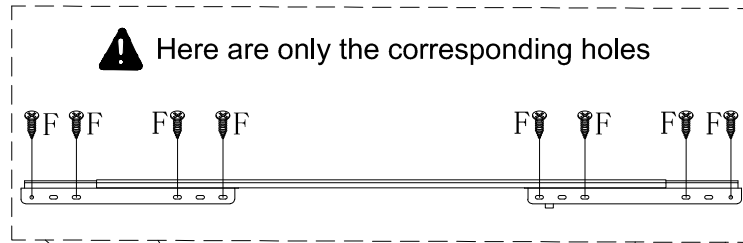

No. F  
Quantity: 16 Pcs  
M3.5\*14mm



# STEP 14

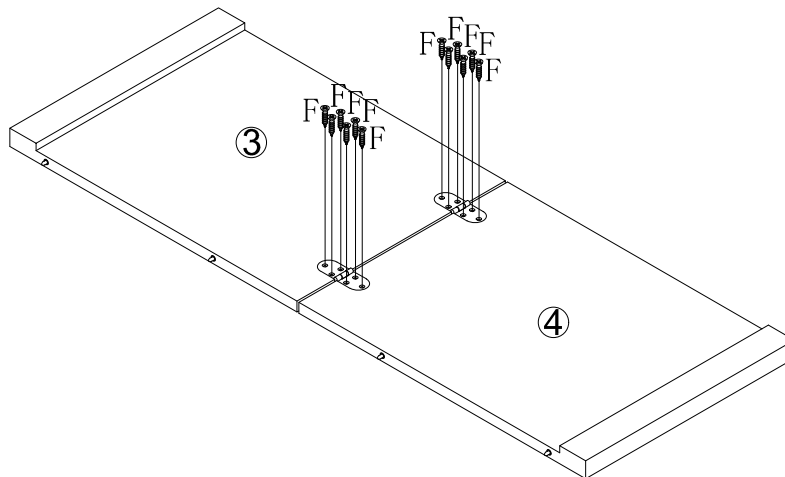

No. F  
Quantity: 12 Pcs  
M3.5\*14mm



No. K  
Quantity: 2 Pcs  
84\*30\*6mm

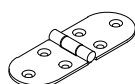

# STEP 15

# Option A installation instructions

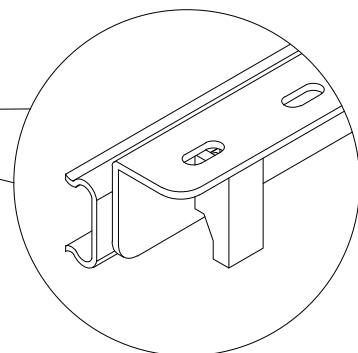
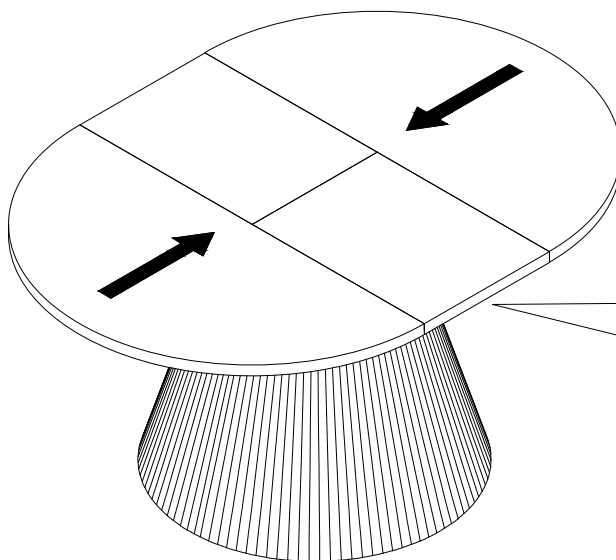
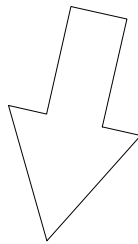
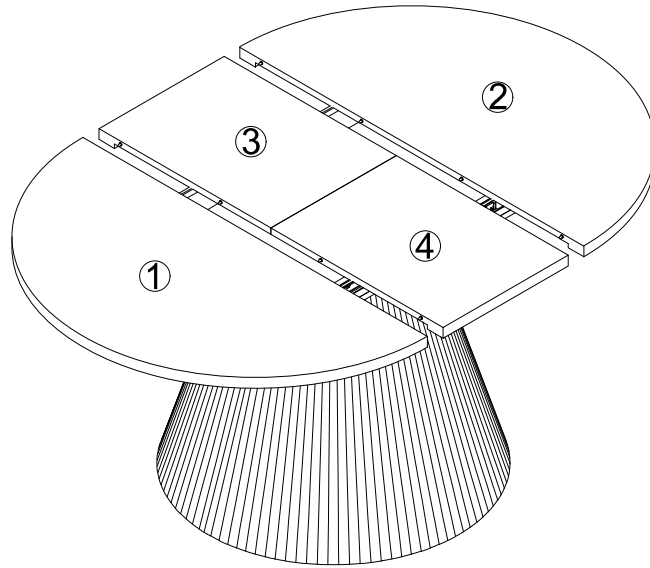

Please note that after the panel is assembled, please lock the black safety latch on the upper side of the slide rail to ensure the safe use of the panel.

# STEP 16

# Option B installation instructions

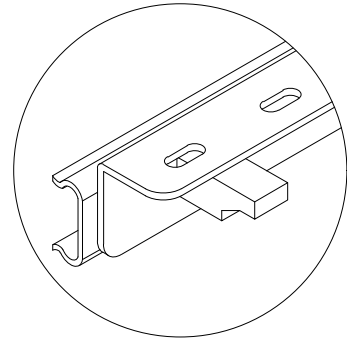
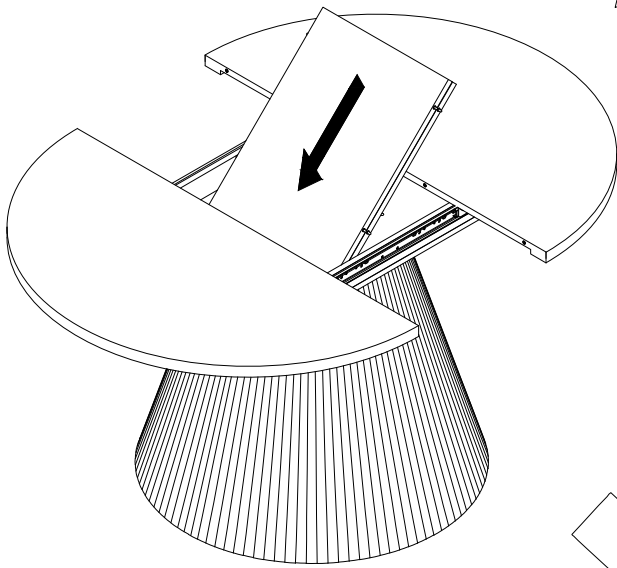
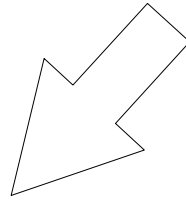
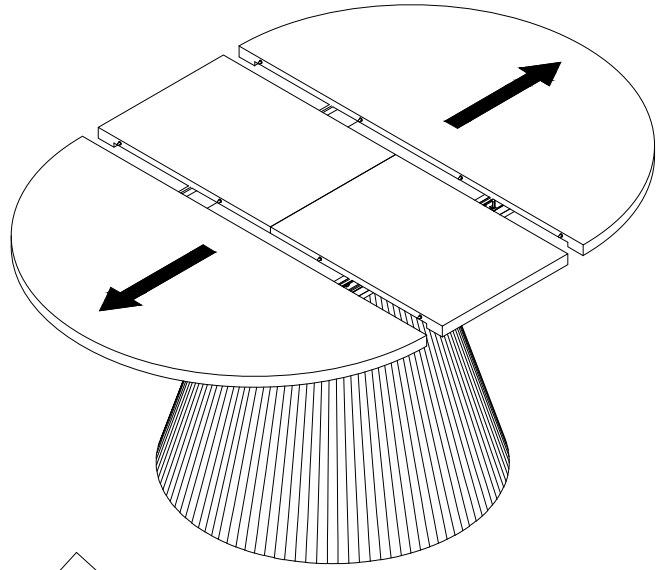
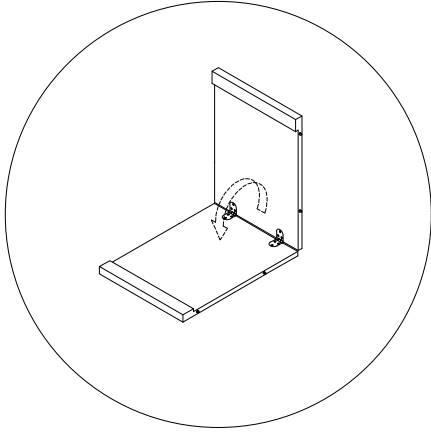

Please unlock the slide track before using this scheme, so that the panel can be pulled open.

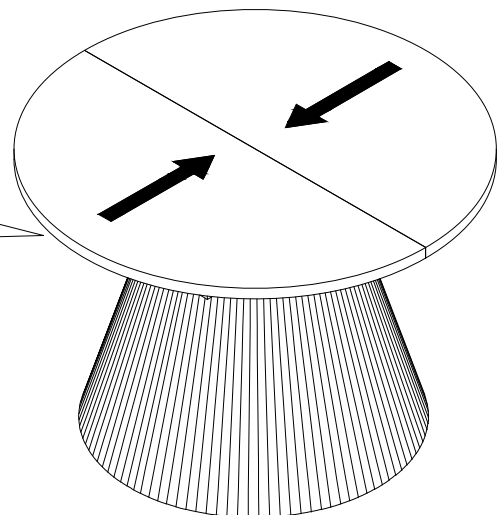
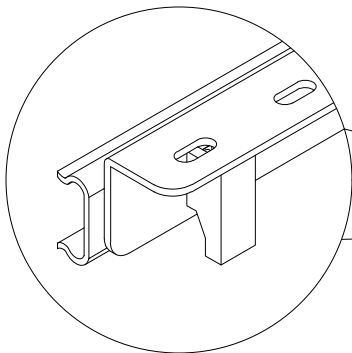
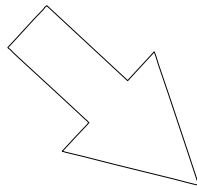

Please note that after the panel is assembled, please lock the black safety latch on the upper side of the slide rail to ensure the safe use of the panel.