



















ASSEMBLY INSTRUCTIONS

Thank you for purchasing the quality product. Be sure to check all packing material carefully for small parts which may have come loose inside the carton during shipment. Separate, identify and count all parts and metal hardware. Compare with all parts list to be sure all parts are present. If any parts (s) are missing or damaged, please contact your local furniture dealer. For efficient and speedy service, please indicate the model number and code letter or part(s) needed.

*****Do not fully tighten screws until fully assembled*****

COMPONENT PART		
DESCRIPTION	PART NAME	QTY
①	Headboard 	1pc
②	Side Rail 	2pcs
③	Footboard 	1pc
④	Slat 	28pcs
⑤	Legs 	2pcs
⑥	Support Legs 	3pcs
⑦	Center Rail 	1pc
⑧	Side Wing 	2pcs

HARDWARE REQUIRED

- (A)  JCBC M6 x 40 - 3pcs
- (B)  M4 x 65mm - 1pc
- (C)  M5 x 70mm - 1pc
- (D)  CSK Screw 25mm - 2pcs
- (E)  JCBB M8 X 20 - 8pcs
- (F)  Middle Holder - 14pcs
- (G)  End Holder - 28pcs
- (H)  JCBC M6 X 50 - 6pcs
- (I)  Spring Washers - 4pcs
- (J)  Flat Washers - 4pcs

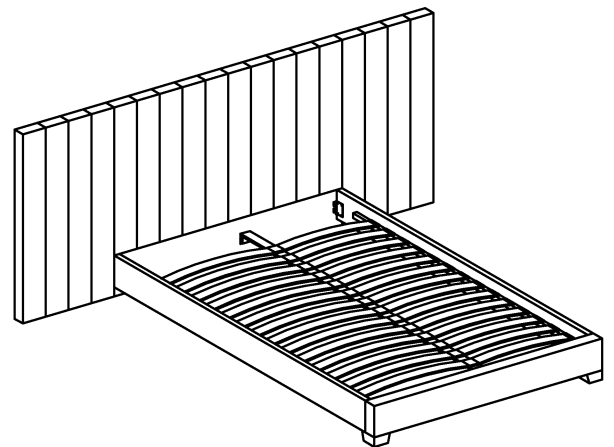

Attention:

*** Some number parts listed on the instruction sheet may not be in parts bag as they may already be assembled. Carefully check parts and packing materials prior to ordering replacements.

How to assemble:

STEP 1 : Tighten the side wing (8) to headboard (1) as shown. Tighten the legs (5) to footboard (3) as shown.

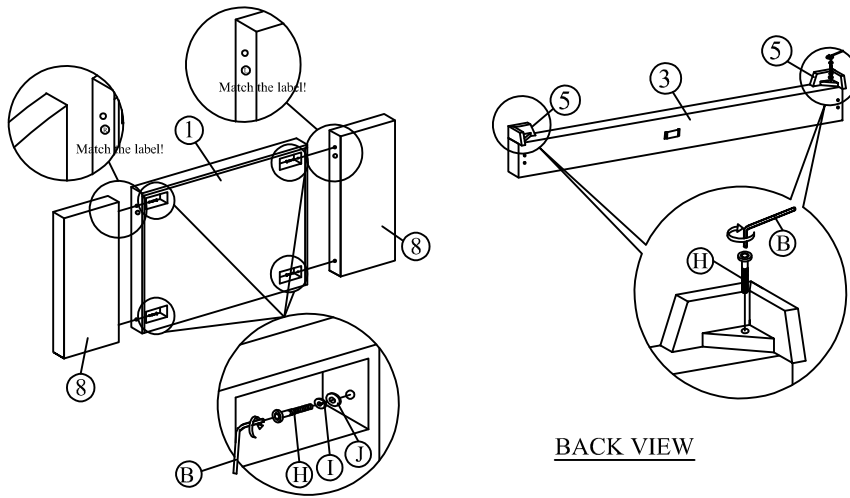

STEP 2 : Attach side rail (2) to headboard (1) and footboard (3) by pushing the bracket down to fit it.

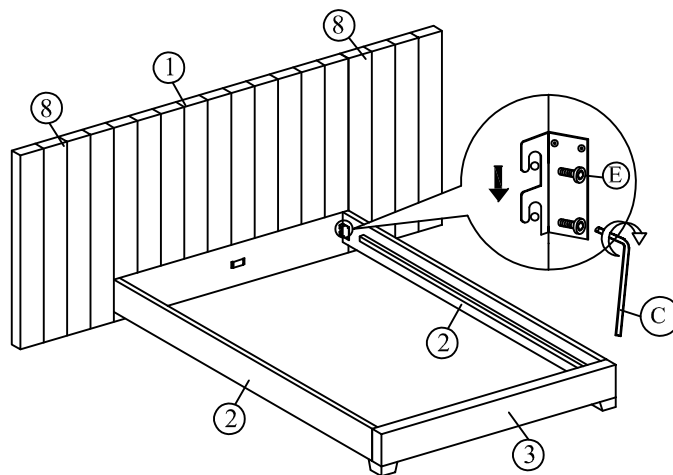

STEP 3 : Attach the support legs (6) to the center rail (7) of the bed as shown.

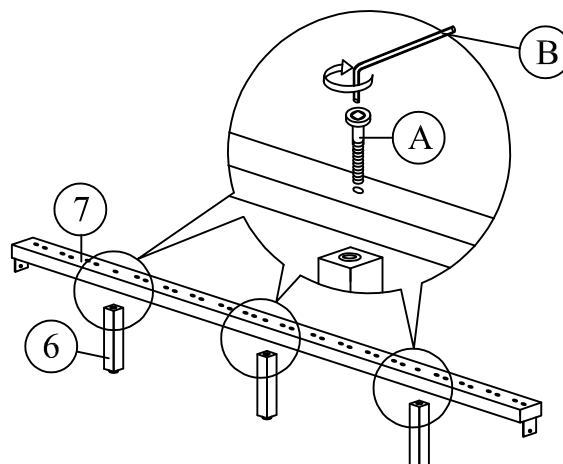

STEP 4 : Slide the center rail (7) to the headboard (1) and footboard (3). Tighten screws (D) using screw driver (not included) to the headboard (1) and footboard (3).

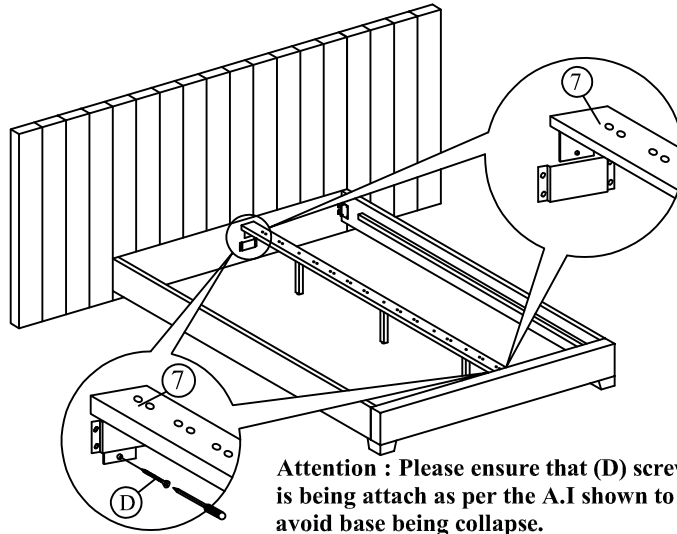

Attention : Please ensure that (D) screw is being attach as per the A.I shown to avoid base being collapse.

STEP 5 : Tighten all the 4 corner, follow by assembly of the slat holders with LVL slats as shown.

