

NOTE:

This brochure contains **IMPORTANT** safety info. Please read and keep for future reference.

MAINTAINANCE AND WARNING

- 1.Keep furniture away from heat sources.
- 2.Do not clean furniture with harsh cleaner or polishes.Do not use detergents,solvents,abrasives,spray packs or leather cleaner. Use non-color mild soa with warm water to clean spills(Mix 1:10 soap to water).
- 3.Do not place furniture under direct sunlight,material will possibly fade over time.
- 4.Do not use on site dry cleaning machine.Children should not climb or jump on the furniture.
- 5.Do not write on furniture that is not protectedby a padded barrier.
- 6.Not for commercial use,only for residential use.

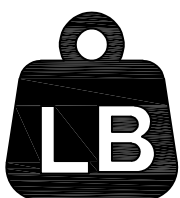

Weight Limitation

100 LBS

EXPLOSIVE VIEW

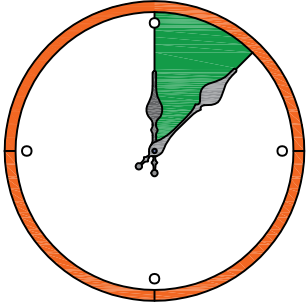
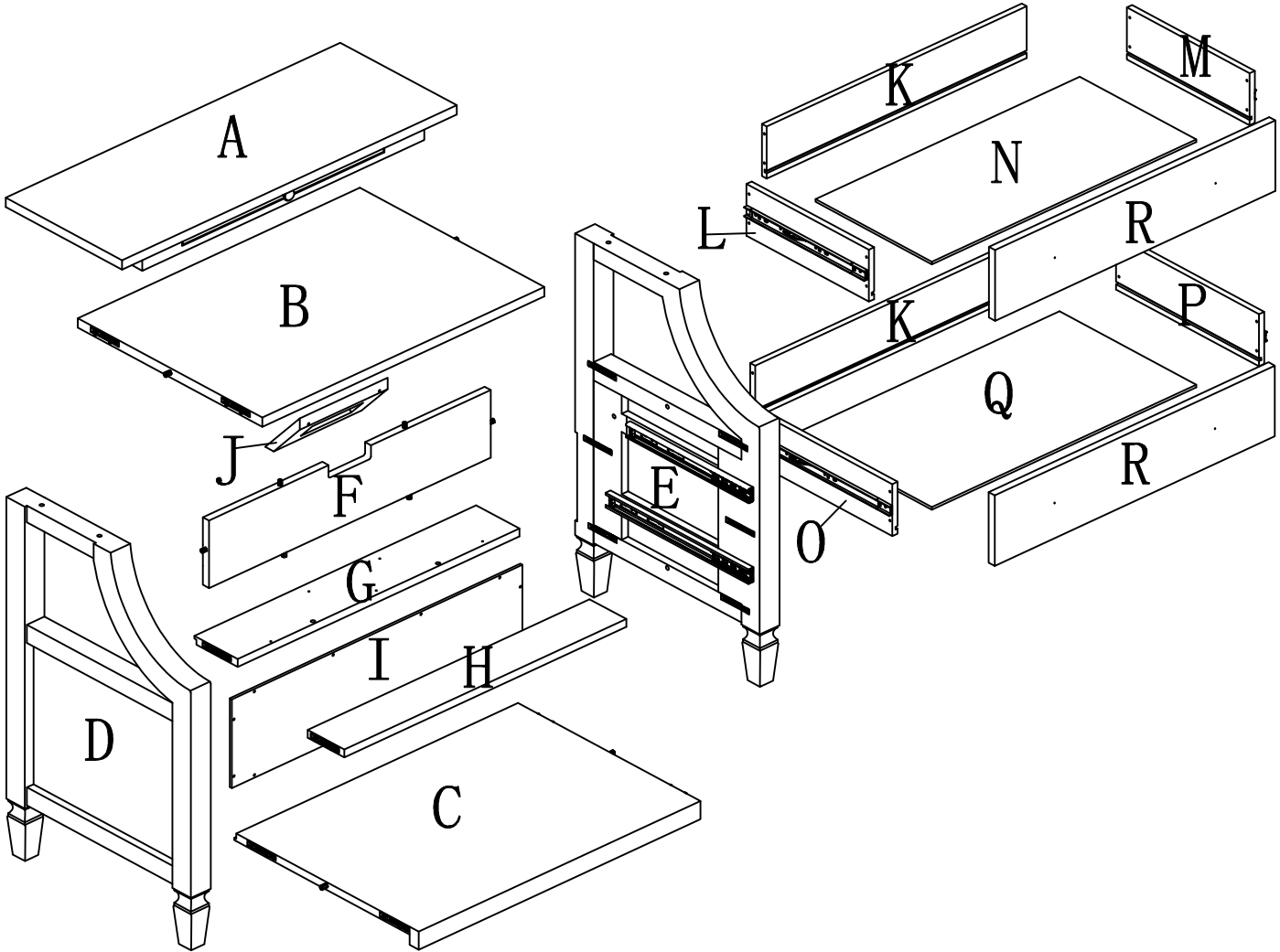

Around 55 min

PARTS LIST

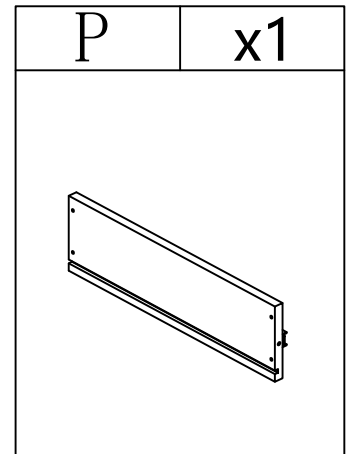
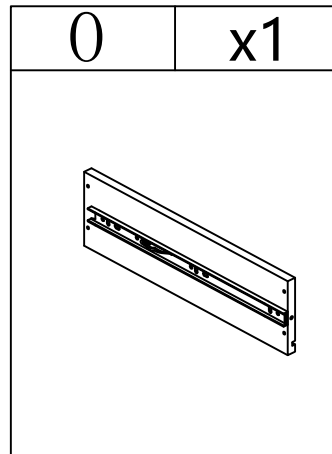
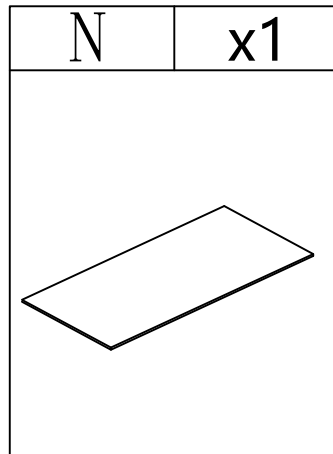
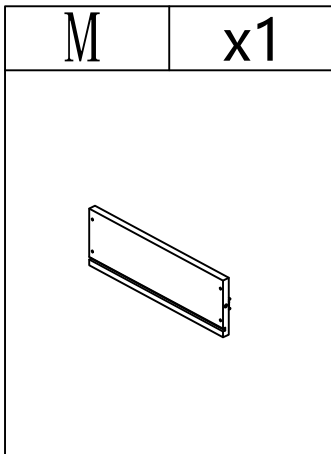
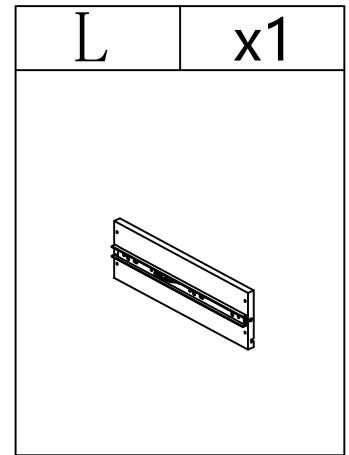
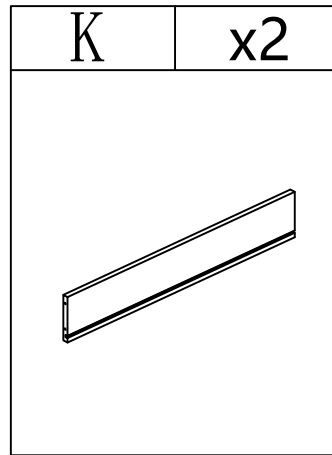
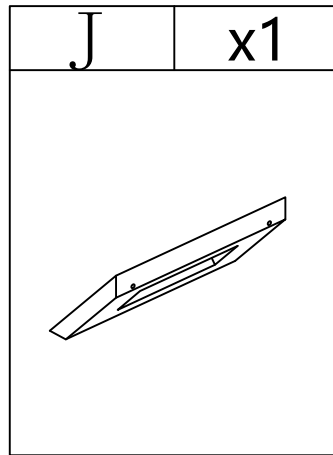
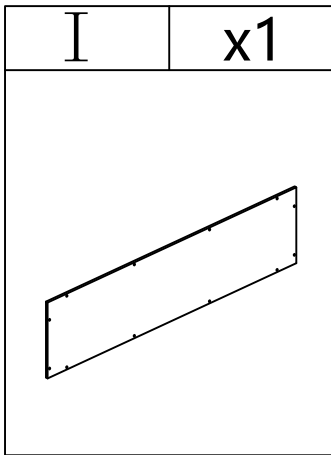
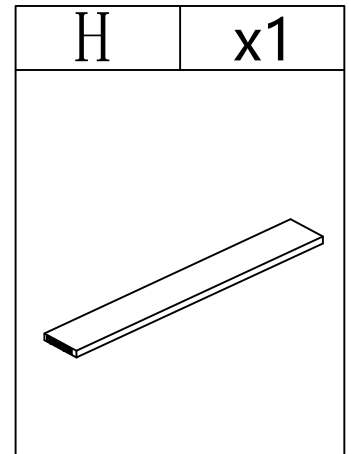
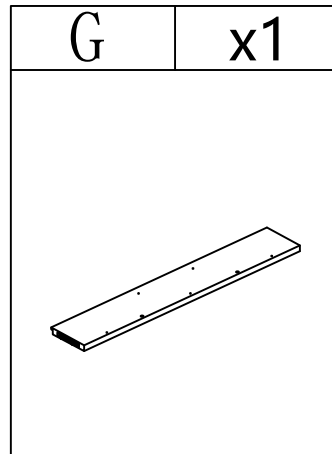
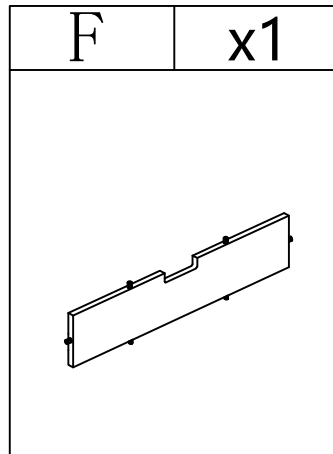
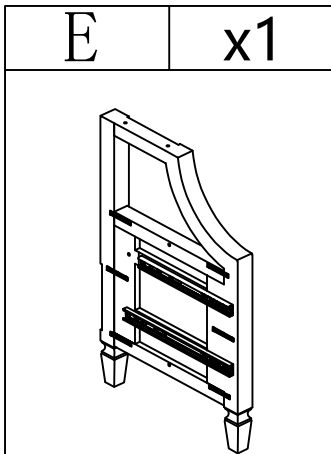
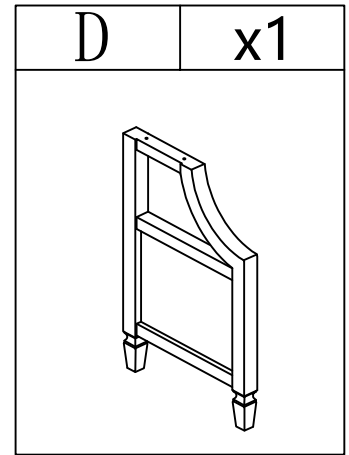
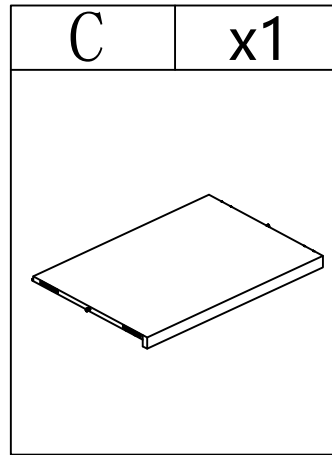
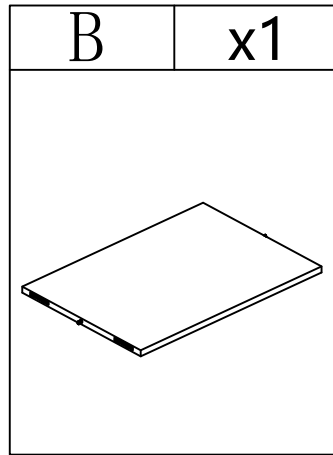
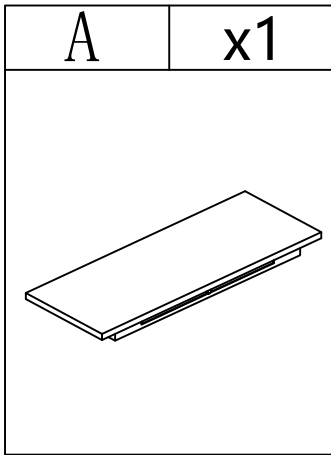



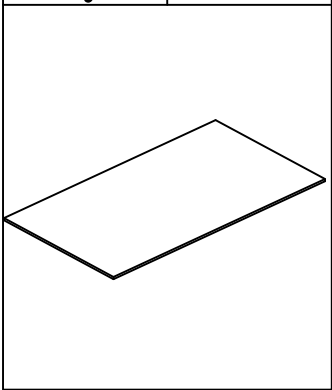

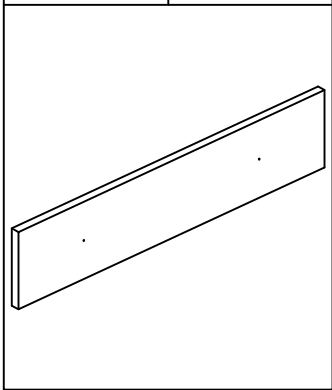

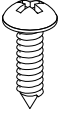
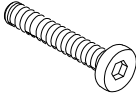

PARTS LIST

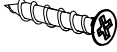
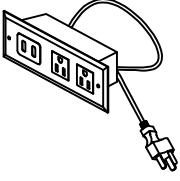
Q	x1
	

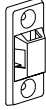
R	x2
	

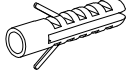
HARDWARE LIST

#1	x12	#2	x4	#3	x4	#4	x2	#5	x23	#6	x1
											
φ3*14mm		φ1/4"*1-1/2"		φ1/4		φ3*12mm		φ8#*1"			
#7	x4	#8	x4	#9	x4	#10	x4	#11	x4	#12	x2
											
		φ5/32"*1"				φ3.5*35mm*7#					
#13	x4										
											
φ3.5*14mm*7#											

TOOL LIST

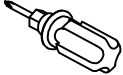
#14	x1	#15	x1
			
M4			

HARDWARE SPARE LIST

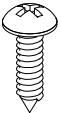
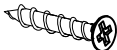
#1	x1	#5	x2
			
		φ8#*1"	

ASSEMBLY INSTRUCTIONS

STEP-1

1. connect part (G) to part (F) with screw #5, tight screw with screwdriver#15 .

2. Insert panel (F & G) into panel (D), make sure all holes aligned and then tighten it with allen key #14 as picture show.

1:

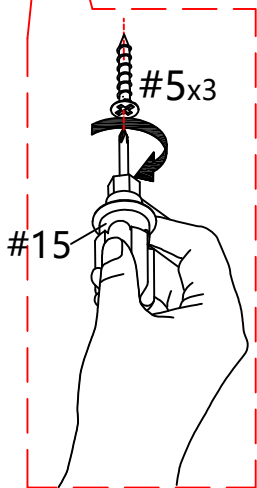
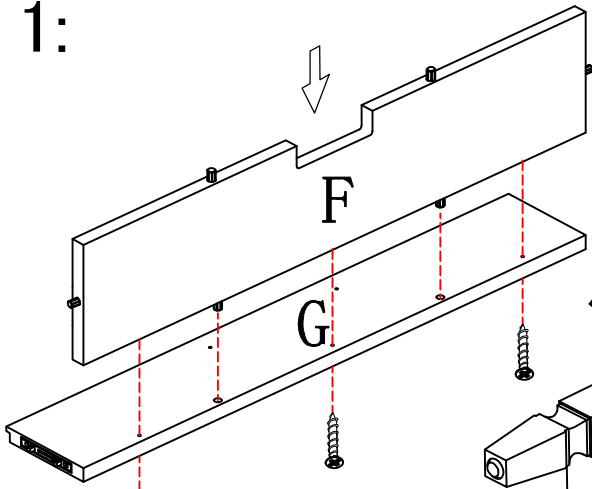

2:

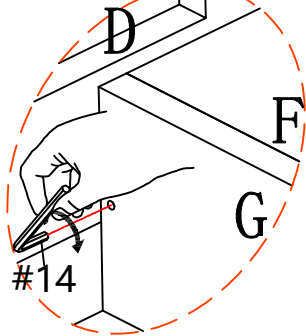
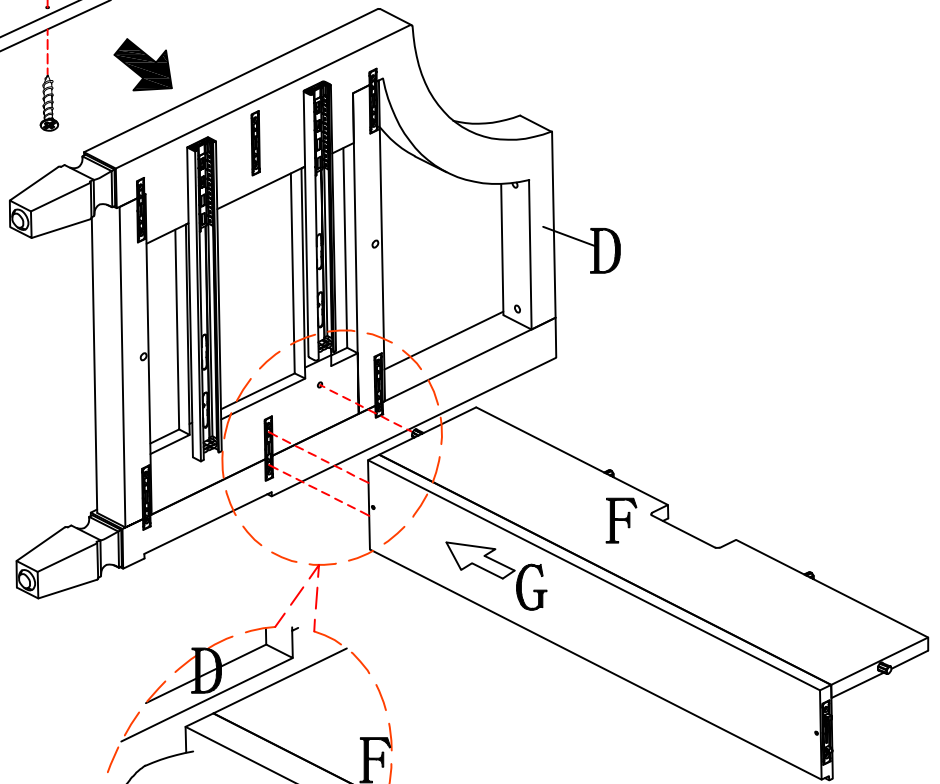

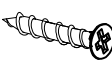
#5	x3
	
ø8#*1"	

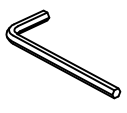
#14	x1
	
M4	

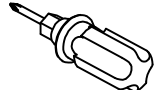
#15	x1
	

ASSEMBLY INSTRUCTIONS

STEP-2

1. Insert panel (B) into panel (D&F), make sure all holes aligned and then tighten it with allen key #14 as picture show.

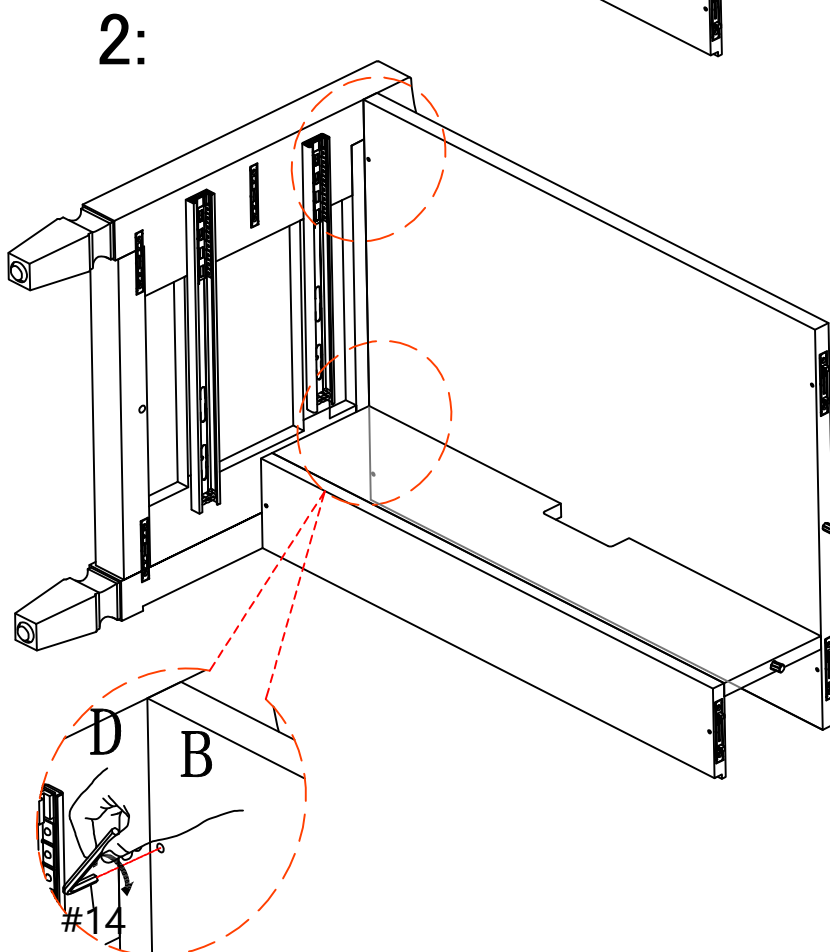
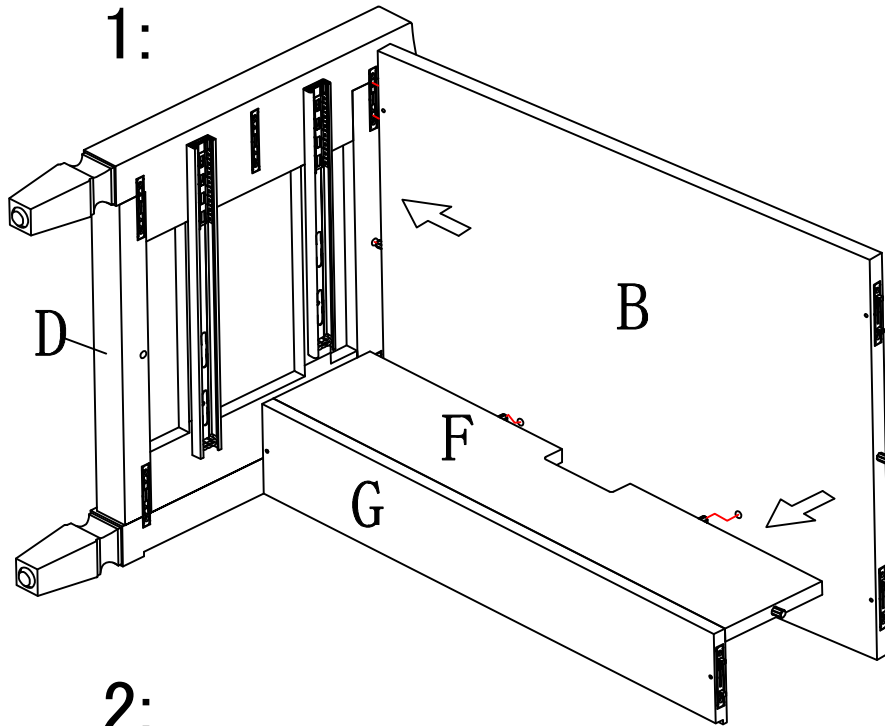

#14	x1
	
M4	

ASSEMBLY INSTRUCTIONS

STEP-3

1. Insert panel (H) into panel (D), make sure all holes aligned and then tighten it with allen key #14 as picture show.

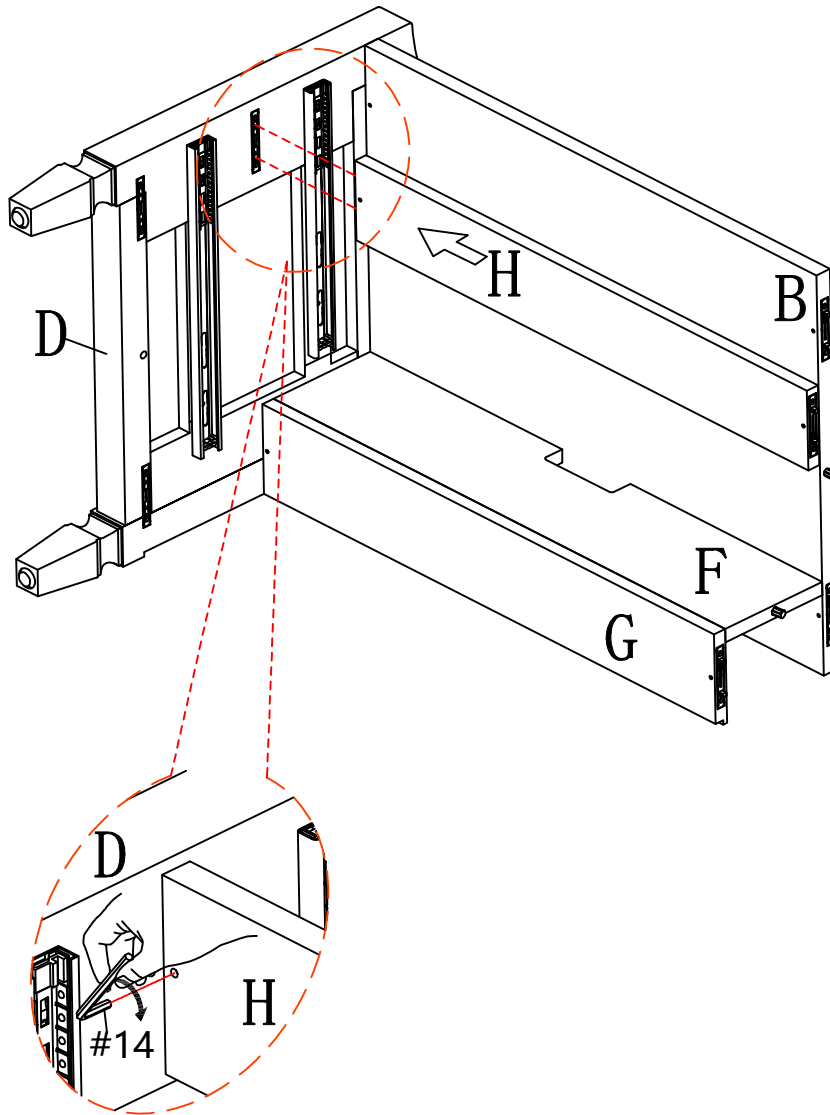

#14	x1
M4	

09/26

ASSEMBLY INSTRUCTIONS

STEP-4

1. Insert panel (C) into panel (D), make sure all holes aligned and then tighten it with allen key #14 as picture show.

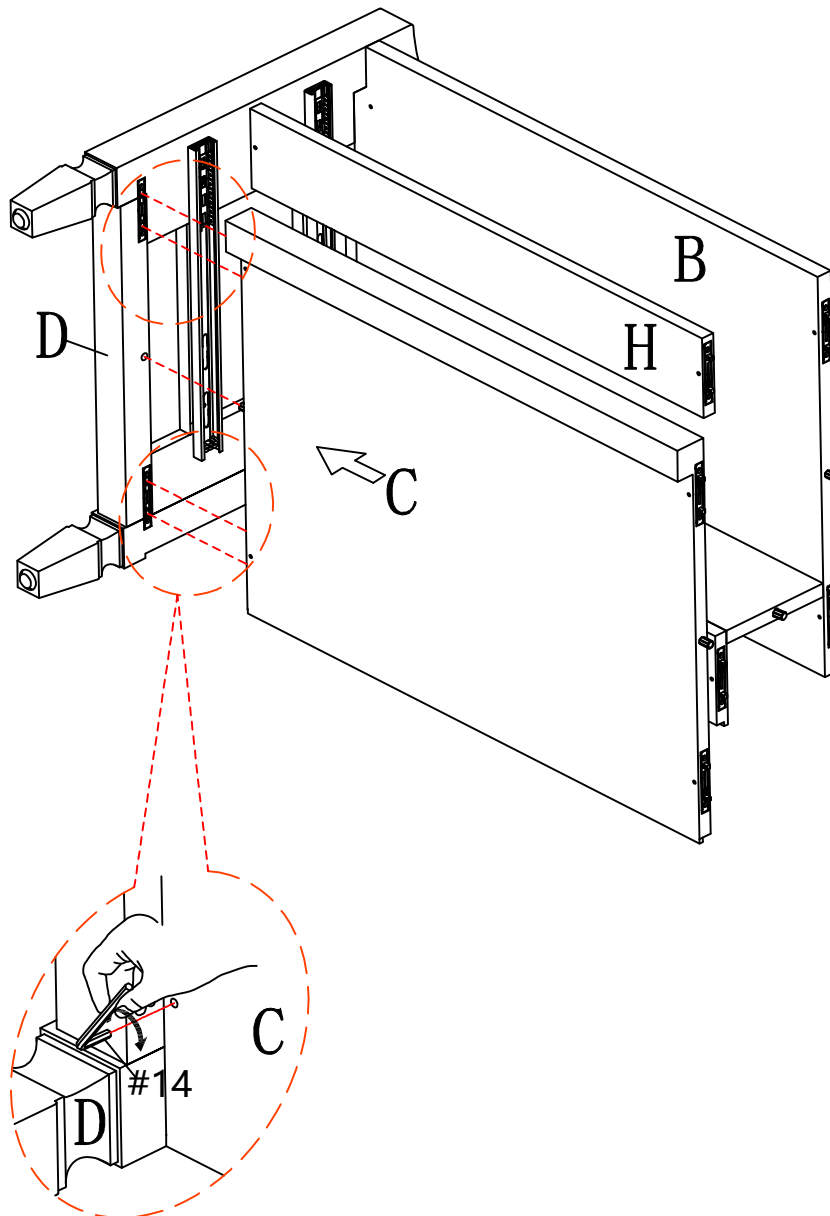

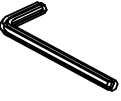
#14	x1
	
M4	

ASSEMBLY INSTRUCTIONS

STEP-5

1. Insert side panel (E) into the corresponding hole of preassembled step 4, make sure all holes aligned and use allen key #14 to tighten it as picture show.

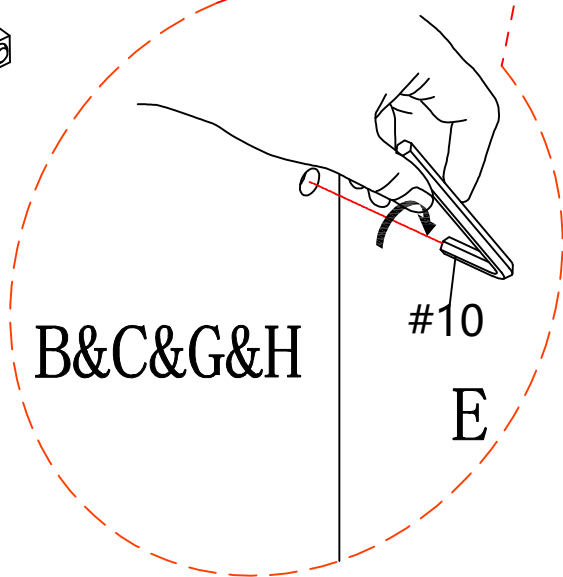
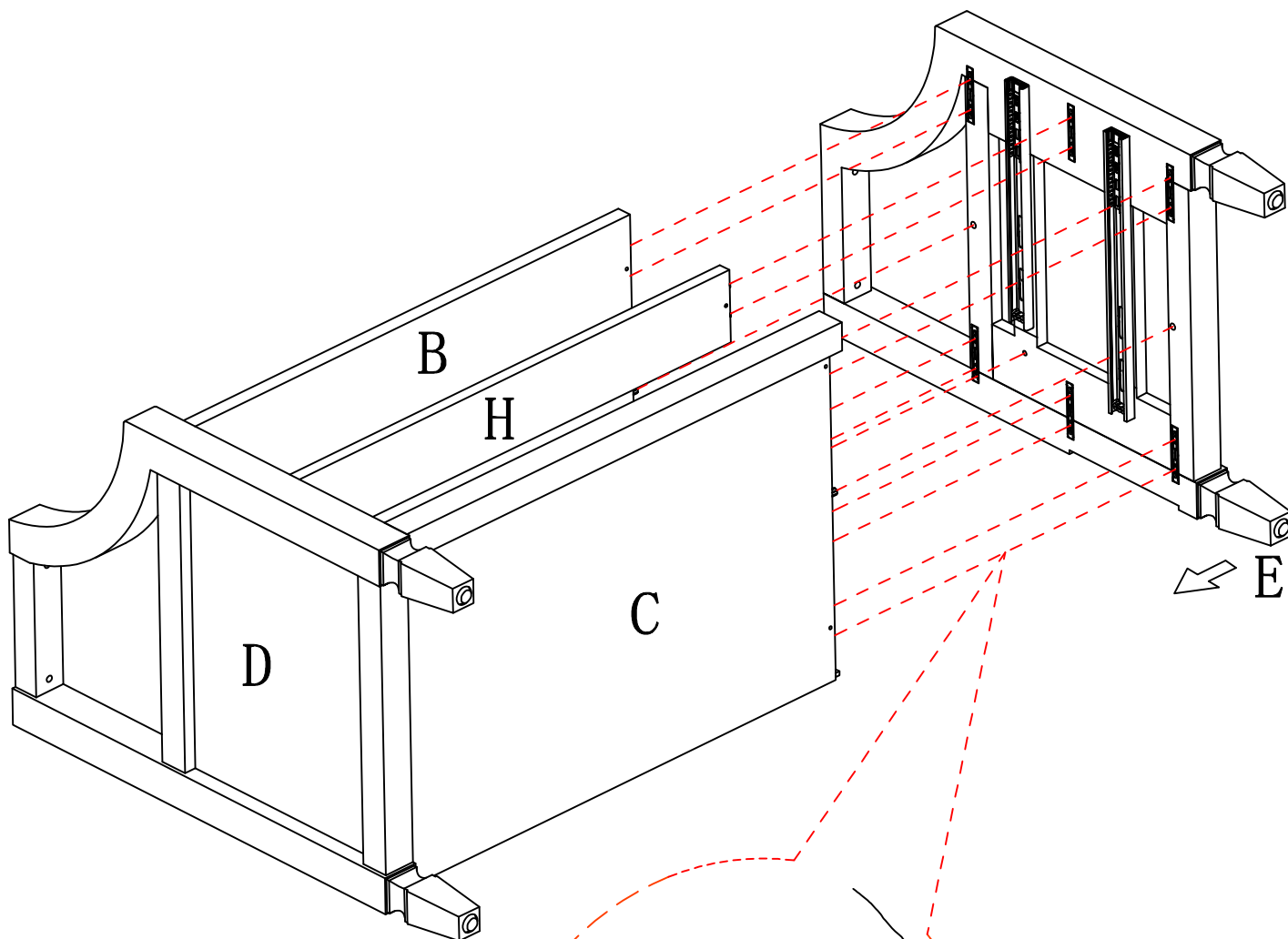

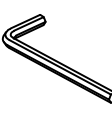
#14	x1
	
M4	

ASSEMBLY INSTRUCTIONS

STEP-6

1.insert back panel(I) into the groove of preassembled step 5,make sure all holes aligned and use screw#1 to attach them , tighten screw #1 with screwdriver#15.

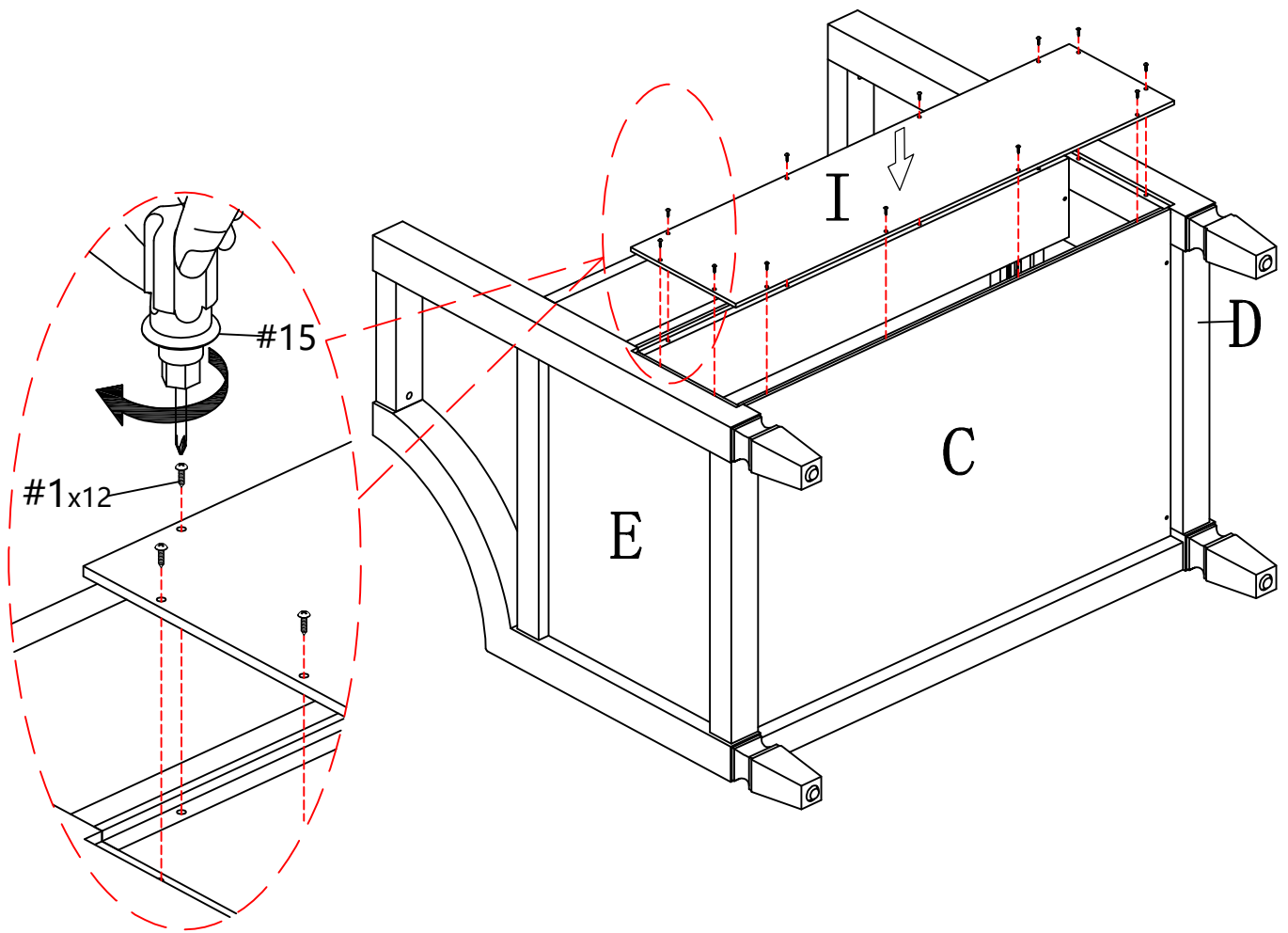

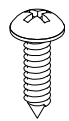
#1	x12
	
ø3*14mm	

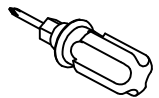

#15	x1
	

ASSEMBLY INSTRUCTIONS

STEP-7

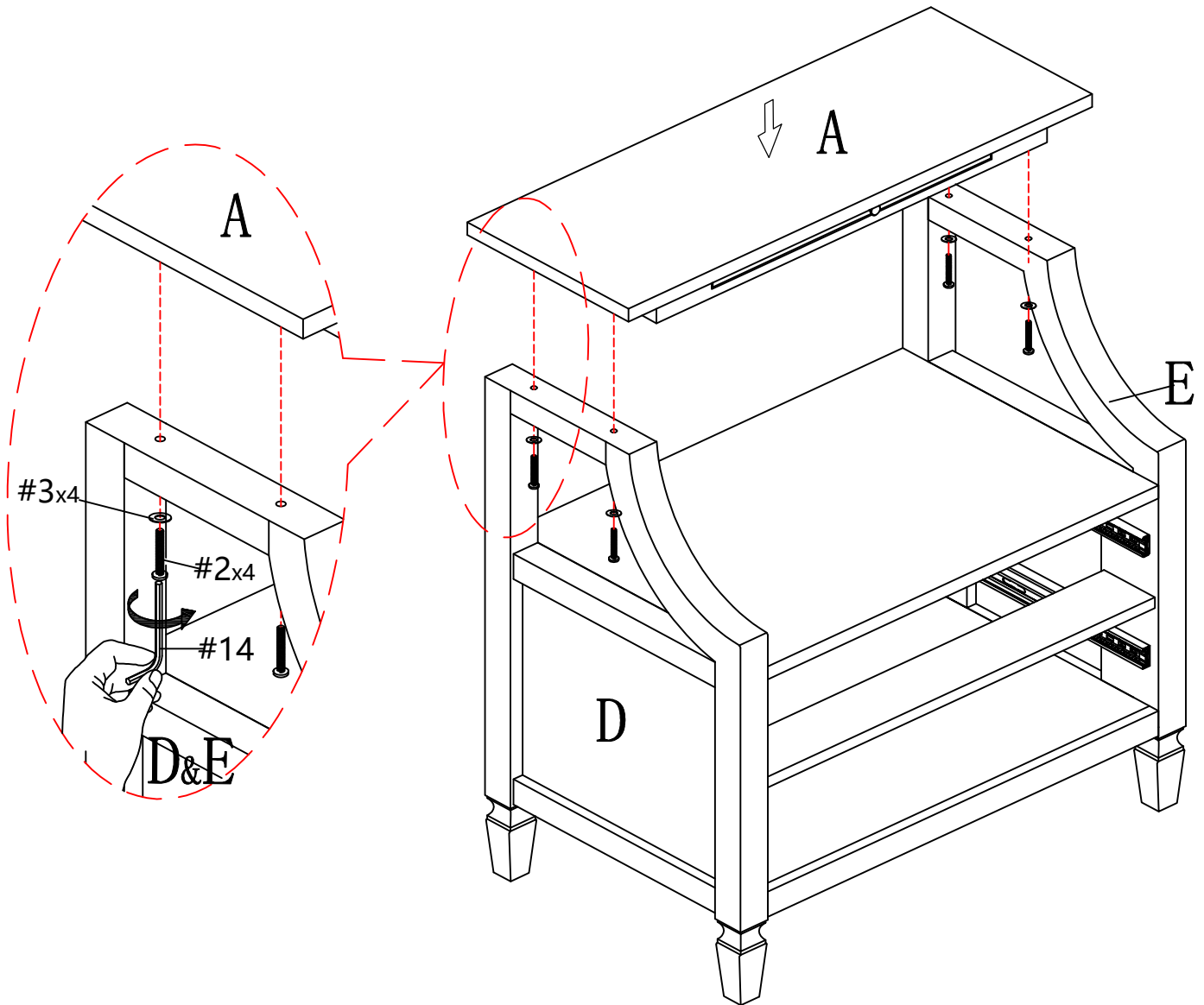
1. Insert gasket #3 into screw #2, Connect panel (A) to preassembled step 6 using bolt #2 and tighten it with Allen key #14.

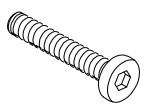

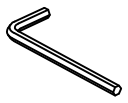
#2	x4	#3	x4	#14	x1
					
ø1/4" * 1-1/2"		ø1/4		M4	

ASSEMBLY INSTRUCTIONS

STEP-8

1.insert part (J) into the preassembled step 7,make sure all holes aligned and use screw#5 to attach them , tighten screw #5 with screwdriver#15.

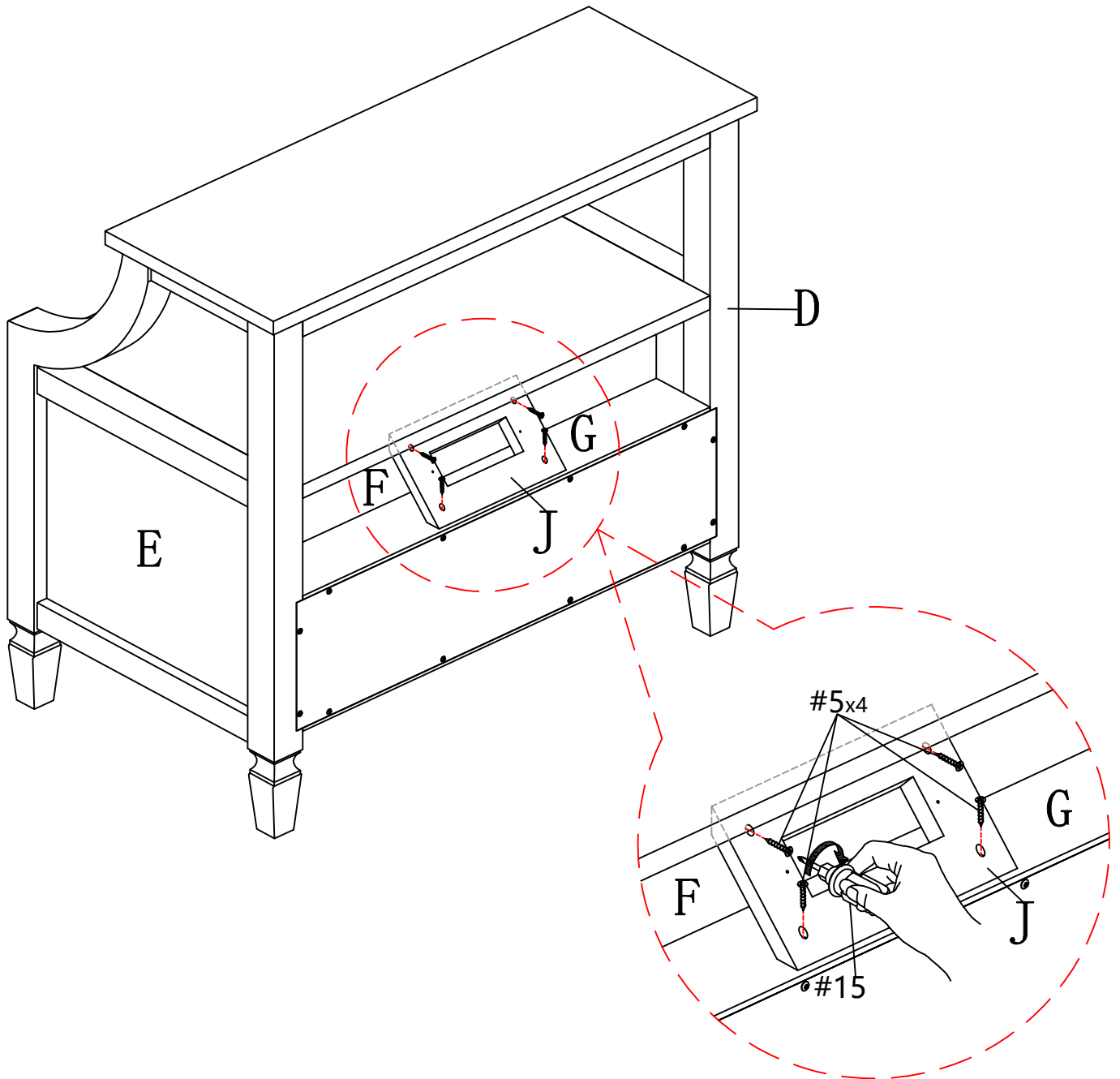

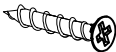
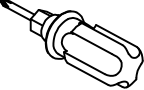

#5	x4	#15	x1
			
φ8#*1"			

ASSEMBLY INSTRUCTIONS

STEP-9

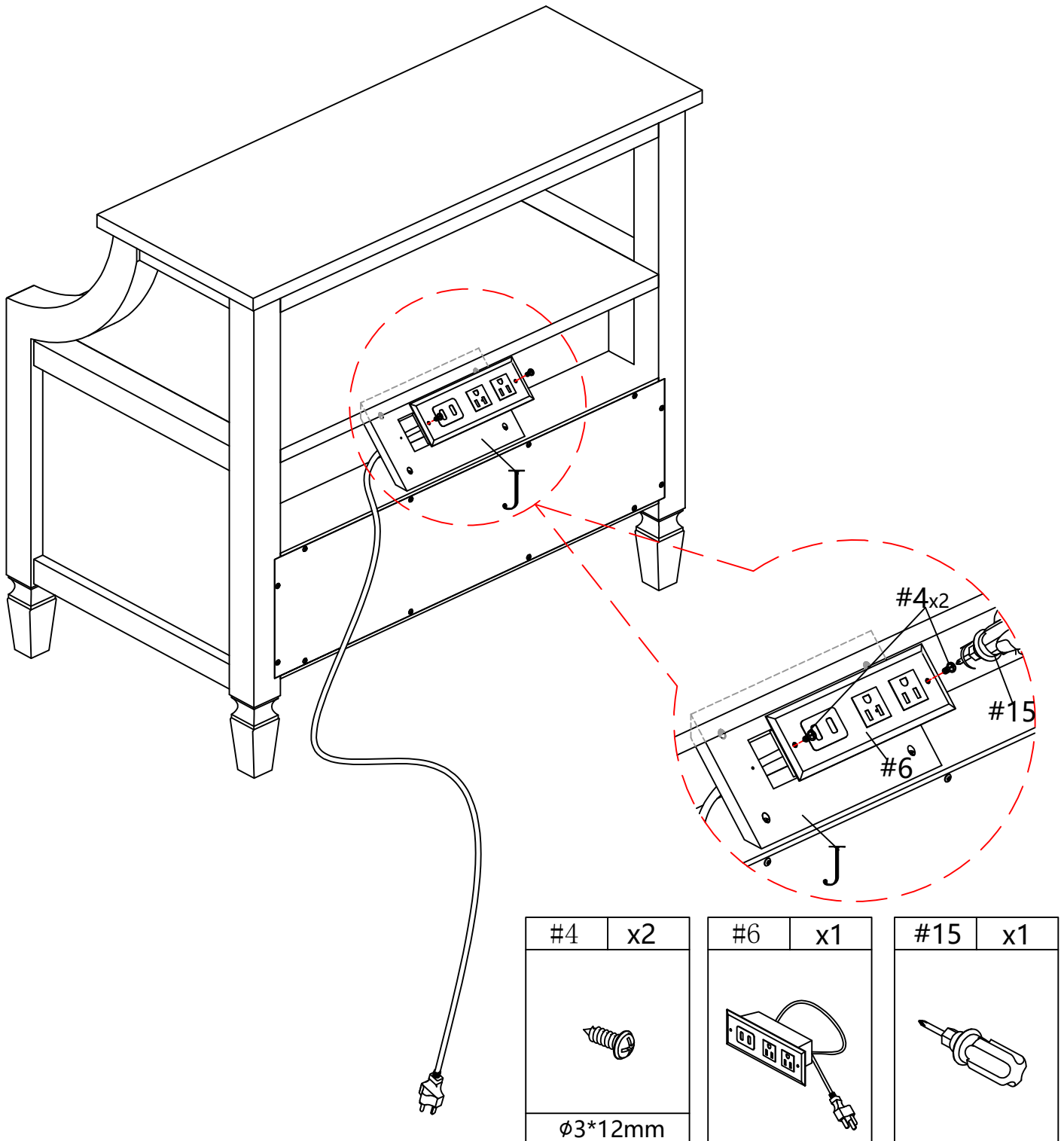
1.insert part #6 into the preassembled step 8,make sure all holes aligned and use screw #4 to attach them , tighten screw #4with screwdriver#15.

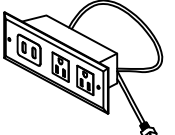
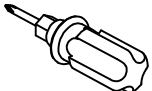

#4	x2	#6	x1	#15	x1
					
φ3*12mm					

ASSEMBLY INSTRUCTIONS

STEP-10

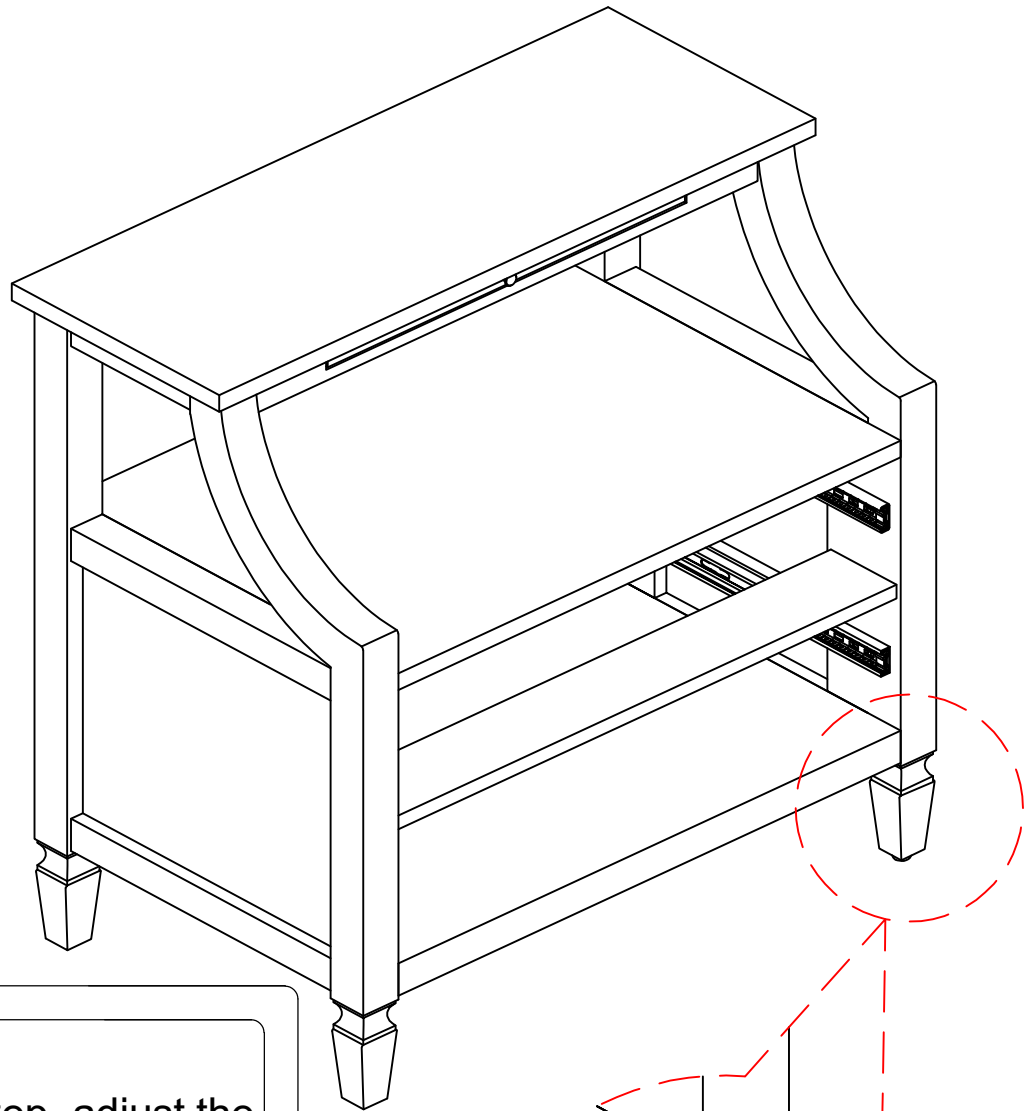

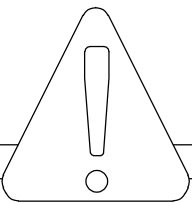

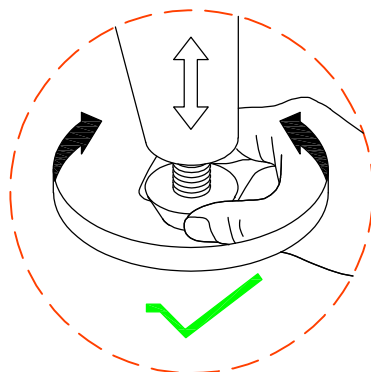
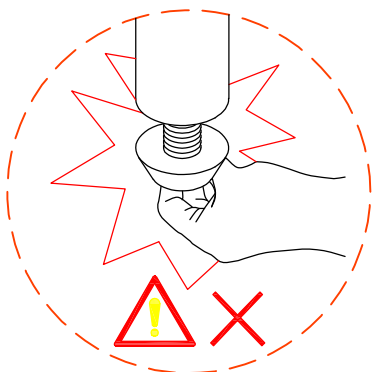
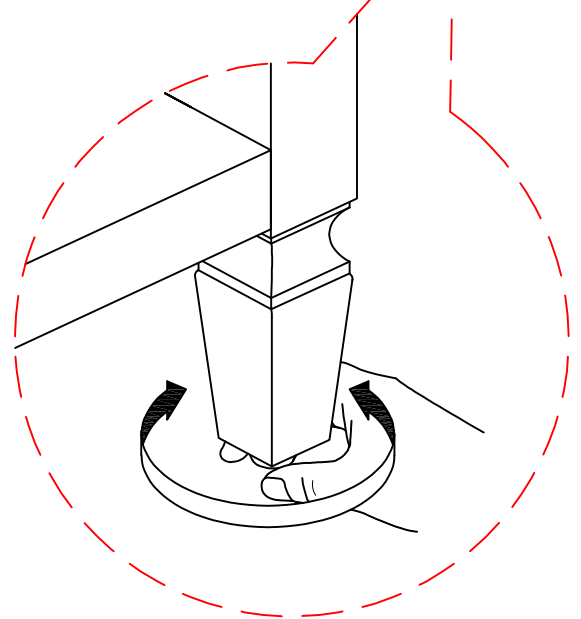
Attention:
Before the next step, adjust the feet of the locker to keep it level.



ASSEMBLY INSTRUCTIONS

STEP-11

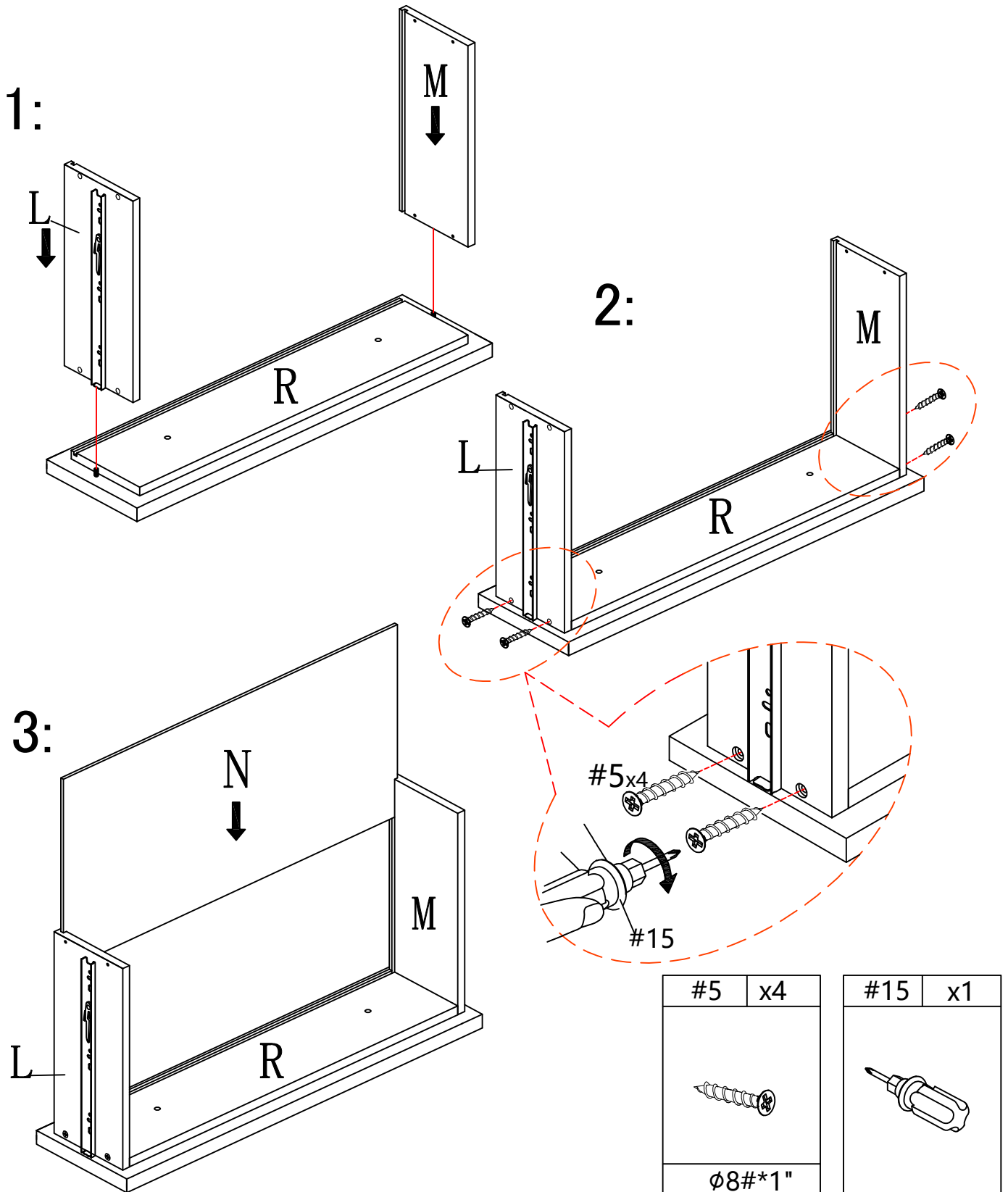
1. Connect part (L&M) to part (R) using screw #5 and tighten it with screwdriver #15. slide in the part (N) into the groove in part (L&M). make sure they are also in groove in part (R).



ASSEMBLY INSTRUCTIONS

STEP-12

1. Connect the (k) and (L&M) using screw #5 , and tighten it with screwdriver #15.

2. Install handle #7 to panel (R) using screw #8 and tighten it with screwdriver #15

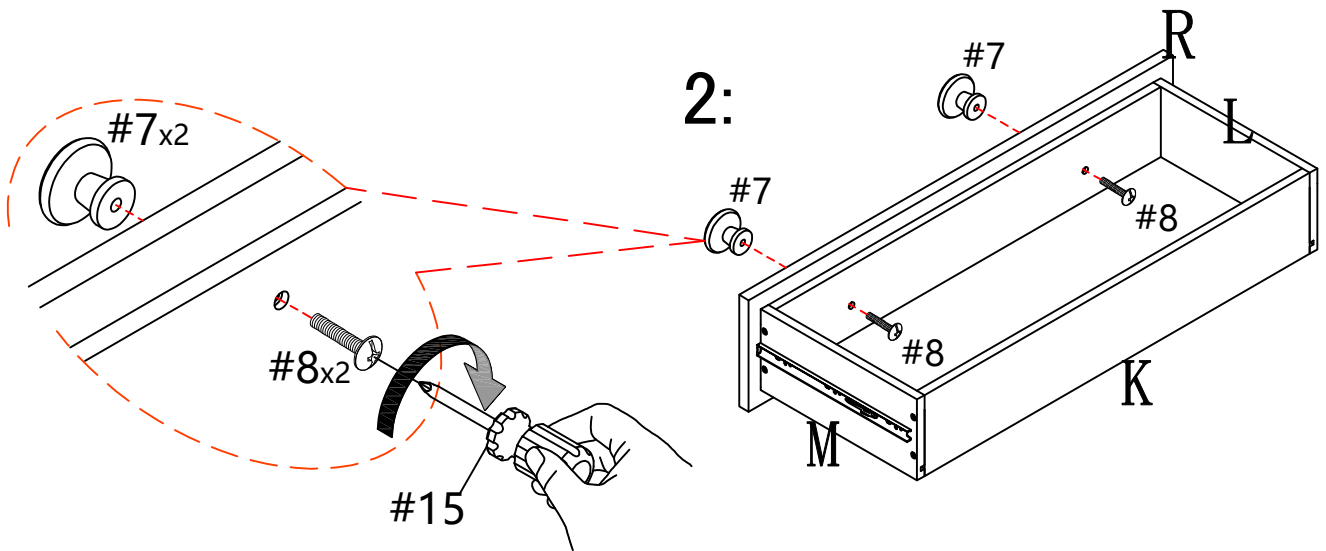
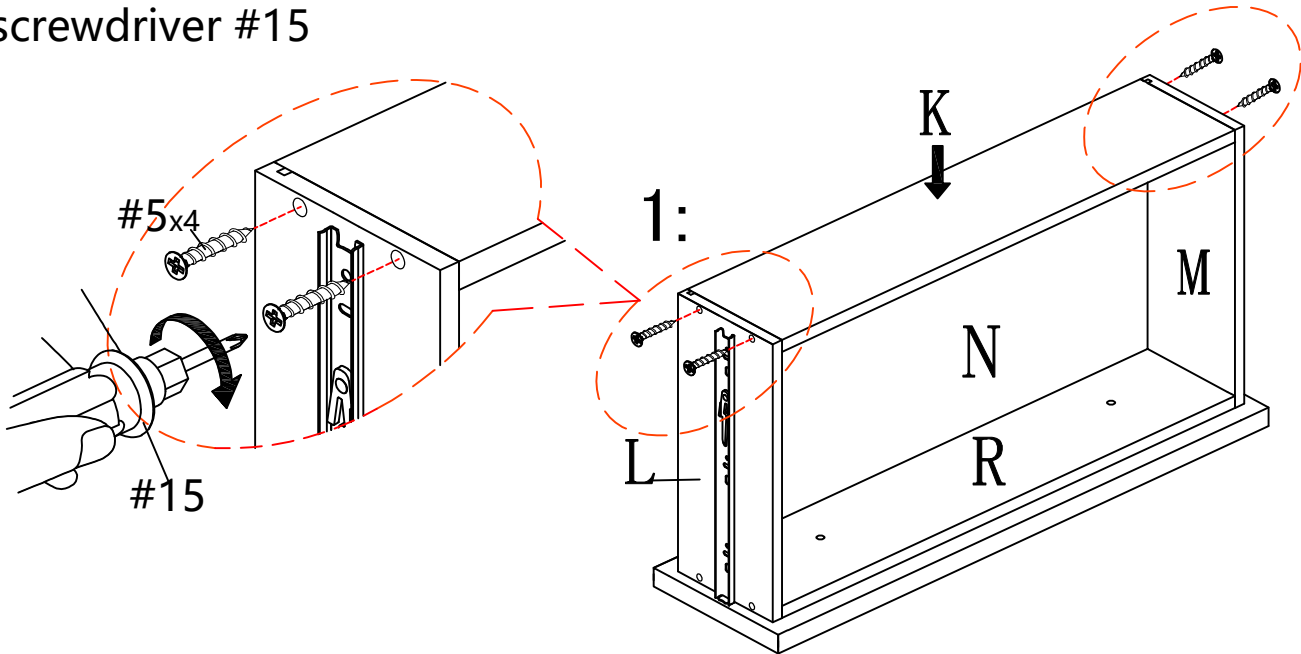

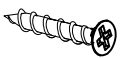
#5	x4
	
φ8#*1"	

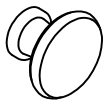
#7	x2
	

#8	x2
	
φ5/32"*1"	

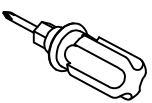
#15	x1
	

ASSEMBLY INSTRUCTIONS

STEP-13

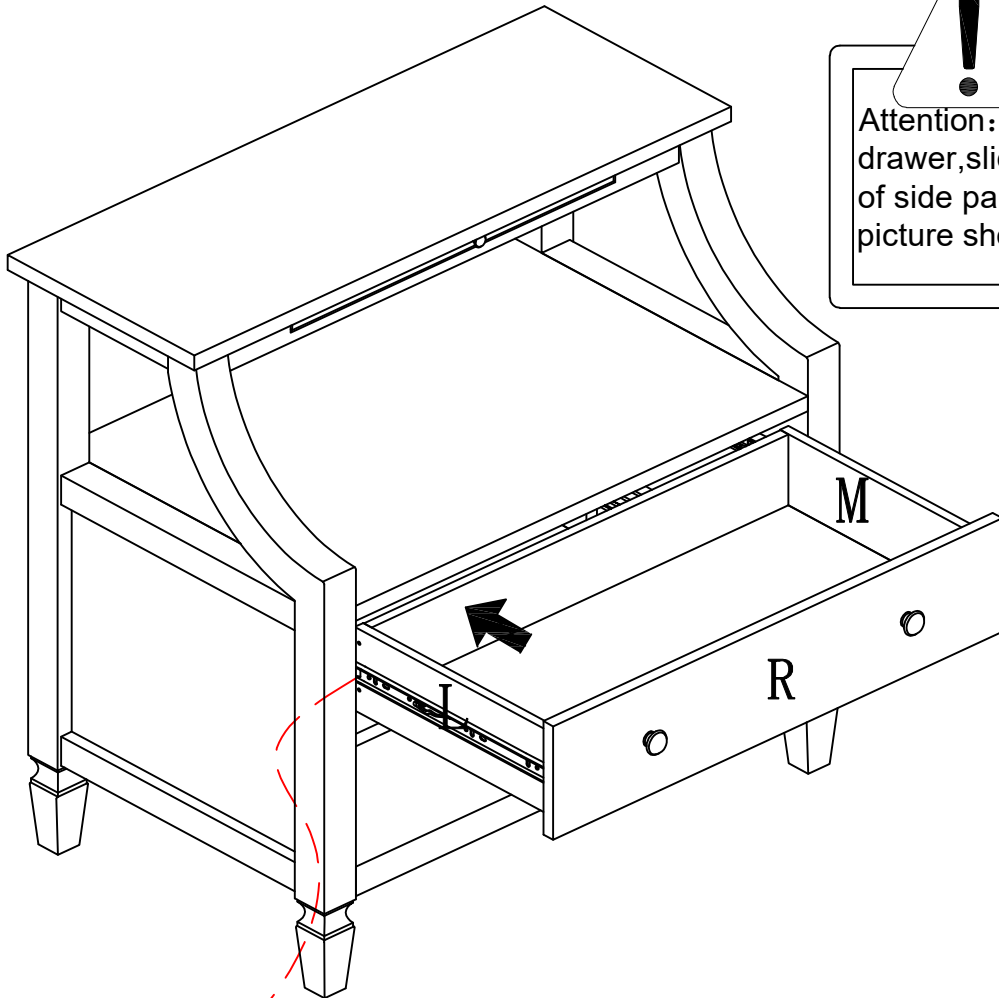

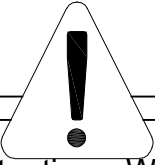
Attention: When installing the drawer, slide the steel ball slide rail of side panel to the most front as picture show.

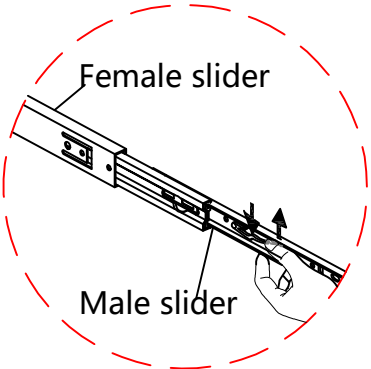

Schematic diagram of slide rail disassembly

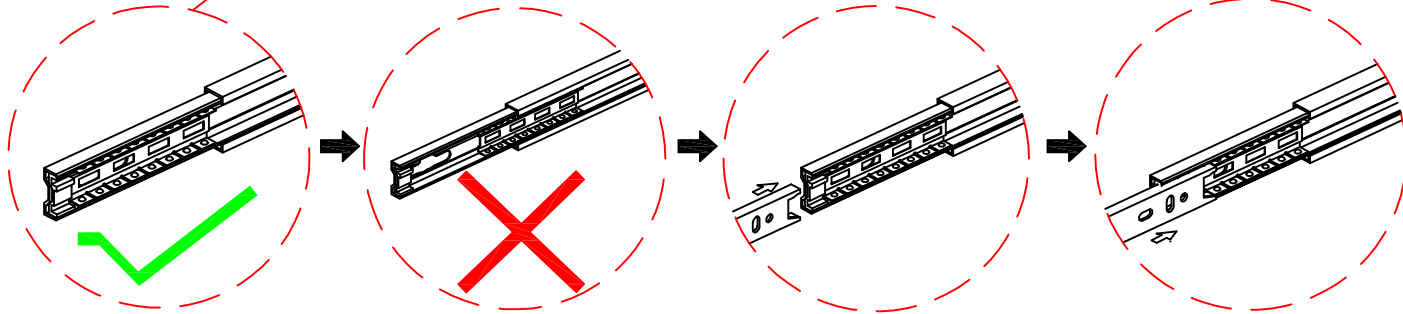

ASSEMBLY INSTRUCTIONS

STEP-14

1. Connect part (O&P) to part (R) using screw #5 and tighten it with screwdriver #15. slide in the part (Q) into the groove in part (O&P). make sure they are also in groove in part (R).

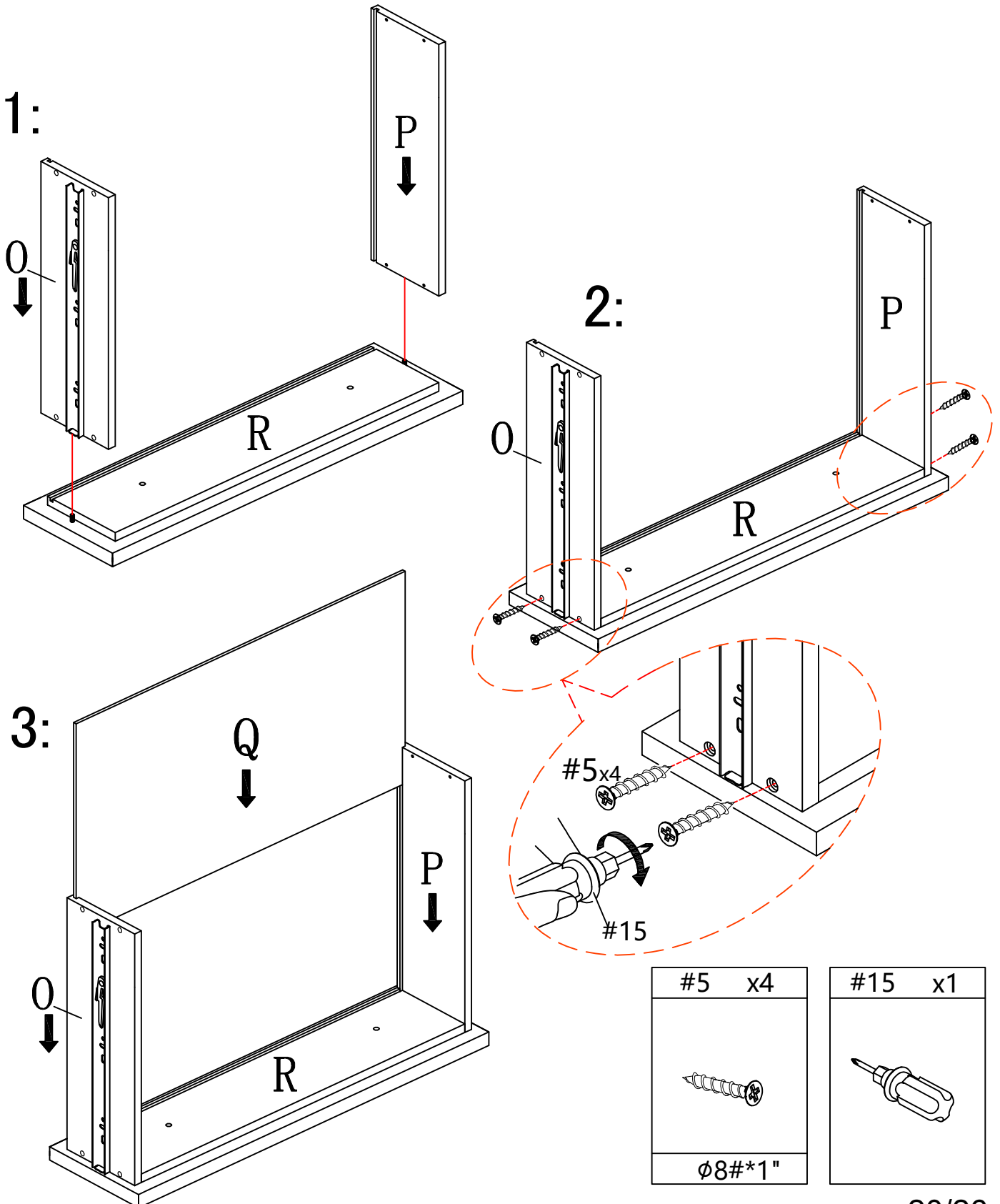



ASSEMBLY INSTRUCTIONS

STEP-15

1. Connect the (K) and (O&P) using screw #5 , and tighten it with screwdriver #15.

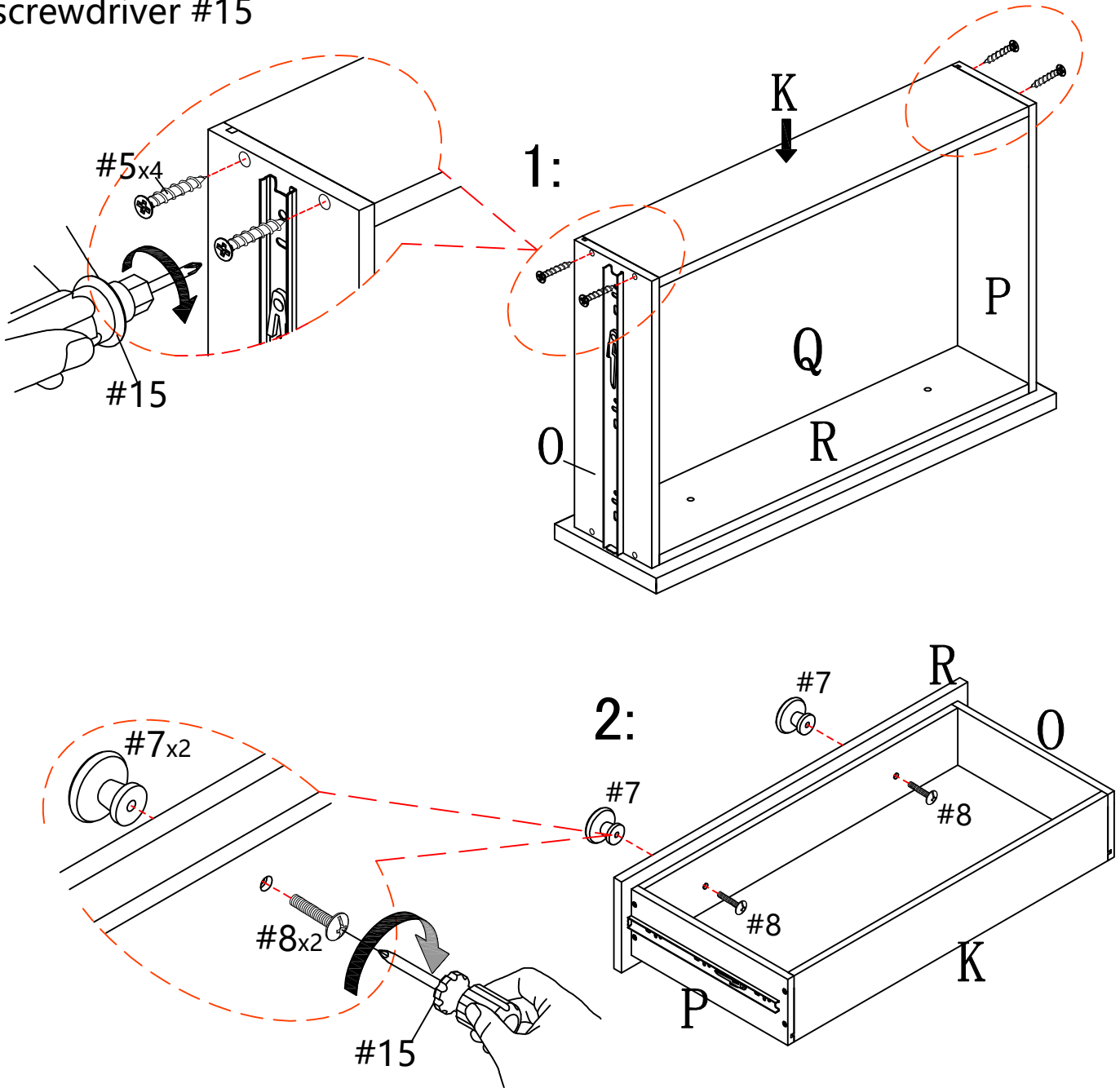
2. Install handle #7 to panel (R) using screw #8 and tighten it with screwdriver #15

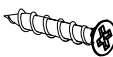

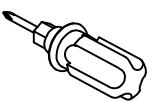
#5	x4	#7	x2	#8	x2	#15	x1
							
φ8#*1"				φ5/32"*1"			

ASSEMBLY INSTRUCTIONS

STEP-16

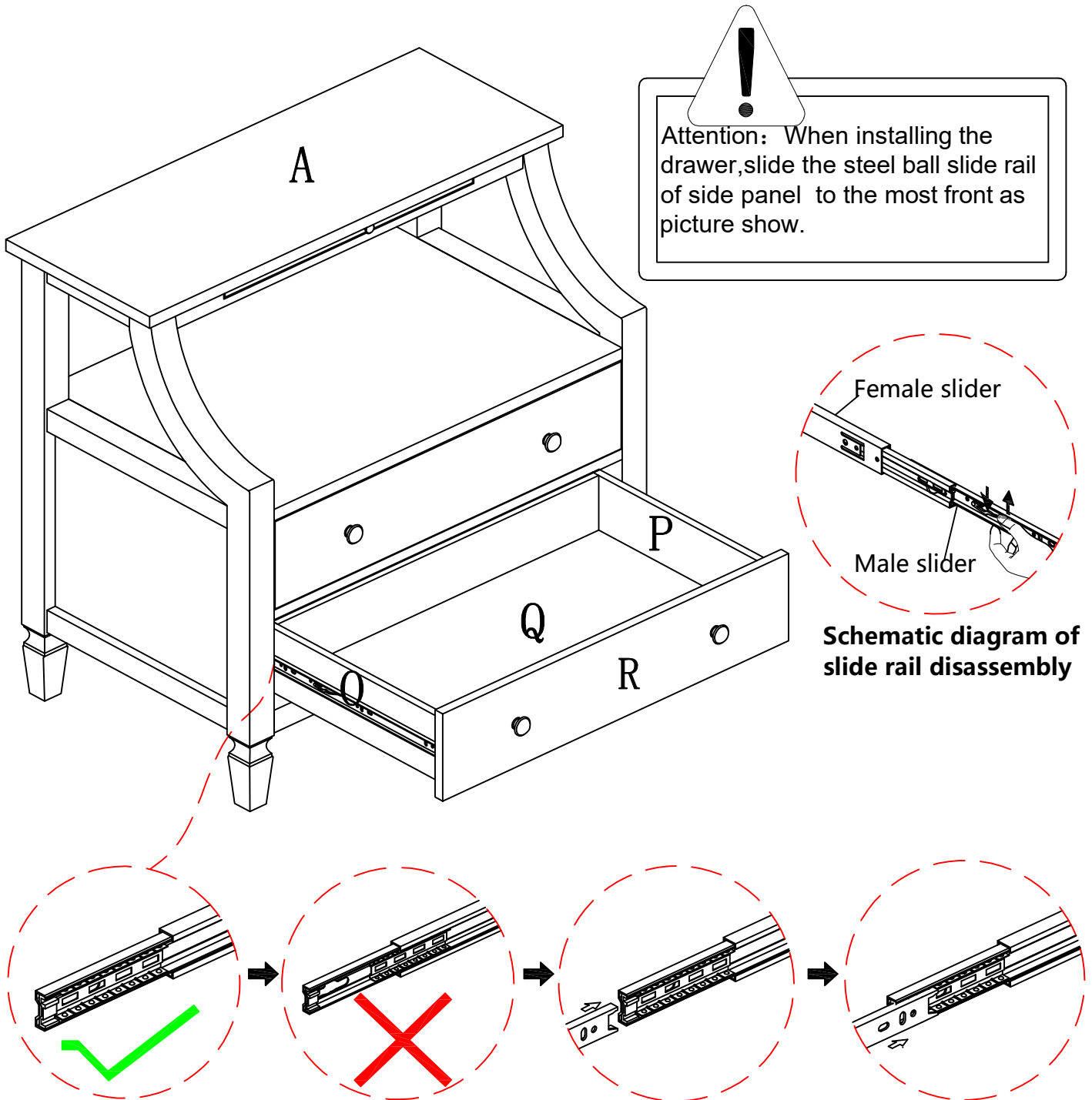



ASSEMBLY INSTRUCTIONS

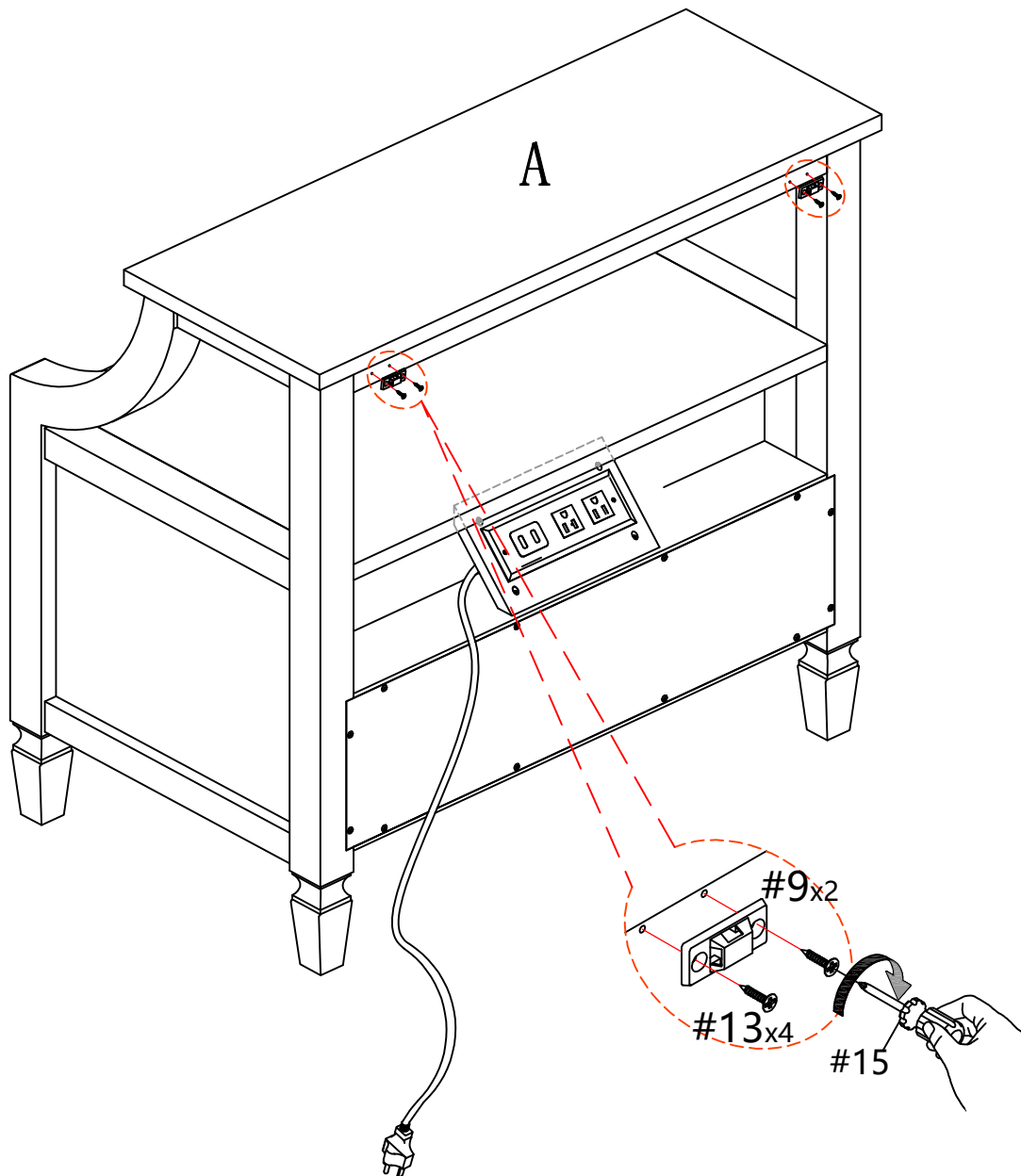

STEP-17

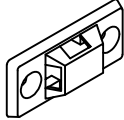
1. Use screw #13 to attach plastic bracket #9 to panel (A), make sure all holes aligned and tighten screw #13 with screwdriver #15.

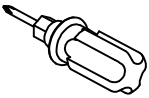

#9	x2	#13	x4	#15	x1
					
		ø3.5*14mm*7#			

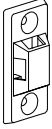
ASSEMBLY INSTRUCTIONS

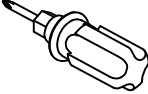
#9	x2	#10	x4	#11	x4	#15	x1
							
		Ø3.5*35mm*7#					

STEP-18

1. Install the anti-collapse device.
2. Mark the position on the wall, that corresponds to the location of bracket (#9) on the Top panel (A); Drill and insert the expandable screw (#11) by hammer.
3. Assemble the bracket (#9) to the well. Align the hole in the bracket (#9) with the expandable screw (#11), use screw (#10) to attach it, tighten screw #10 with screwdriver (#15)

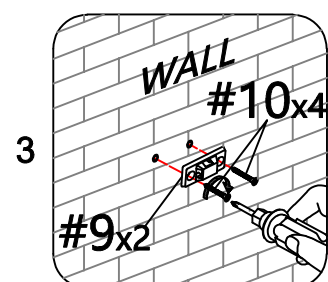
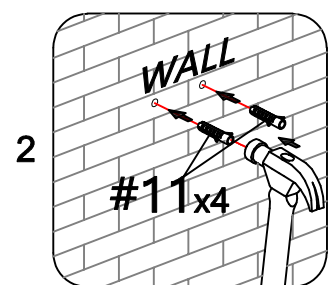
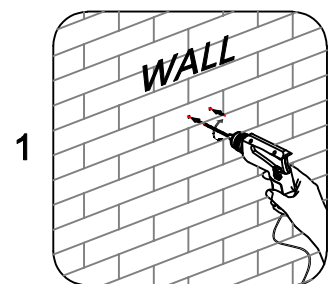
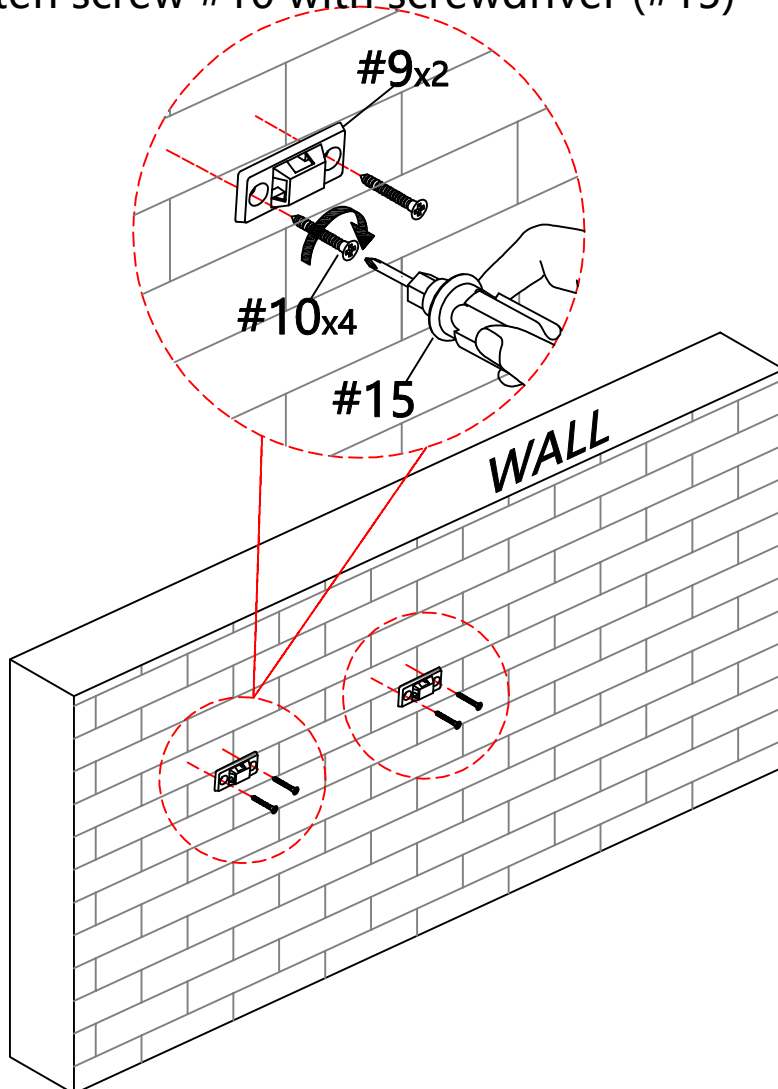

ASSEMBLY INSTRUCTIONS

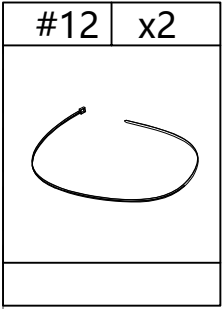

STEP-19

1. Let the plastic belt (#12) pass through bracket (#9) and pull tightly.

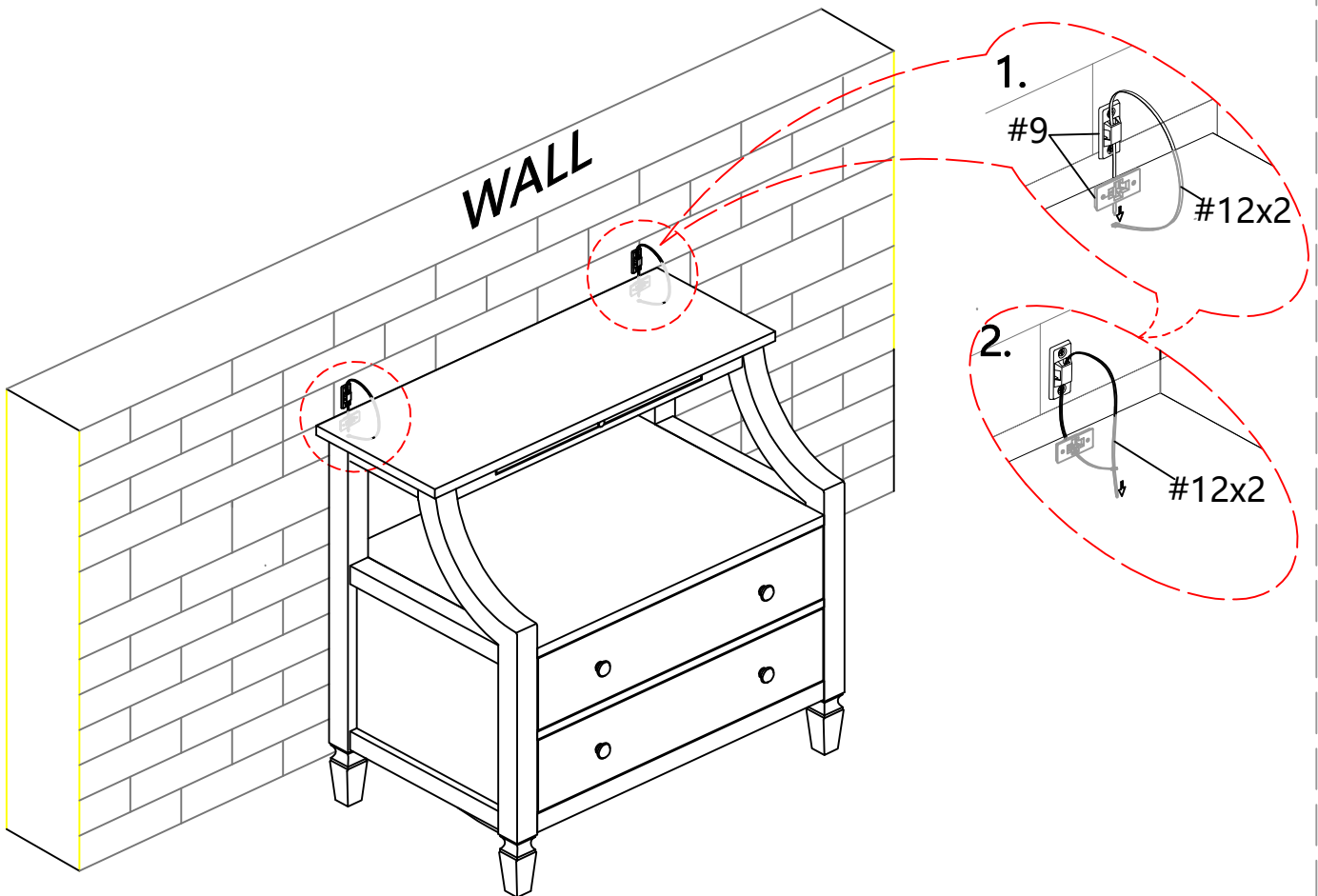

WARRANTY

1. We strive to offer high-quality products, and we also try our best to satisfy each and every customer that orders from us with product or service as needed.
2. We provide 30 days warranty starting from the time you receive the item. Each customer must provide a record of their order such as the order number, or item receipt for any items that are out of the warranty period you may also still receive.
3. Replacement parts by purchasing them with our company if they are available.