

USER'S MANUAL

**Product Name:
Solar Lamp Post with Planter**

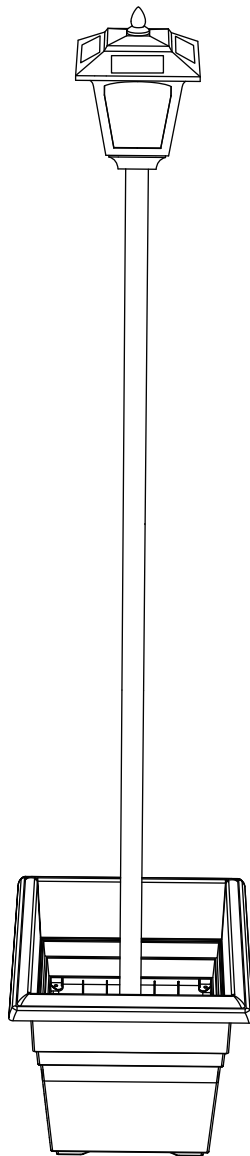

THIS INSTRUCTION BOOKLET CONTAINS
IMPORTANT SAFETY INFORMATION.
PLEASE READ AND KEEP FOR FUTURE REFERENCE.

Package Contents

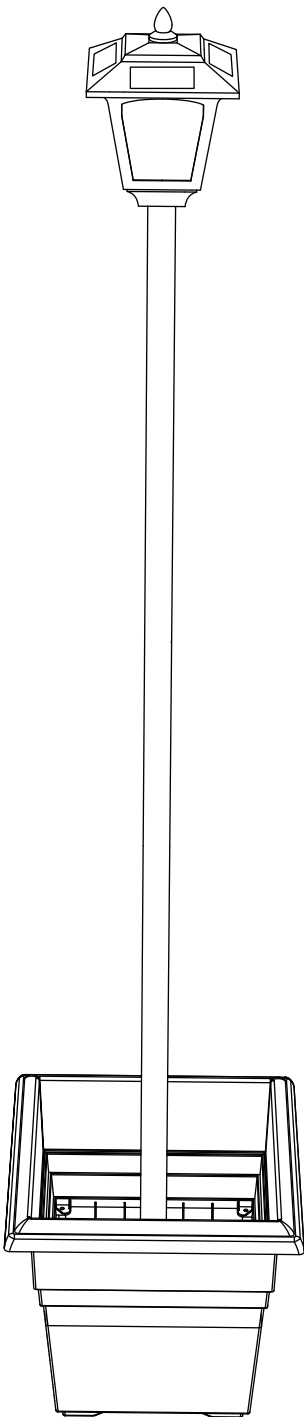

Part ① CAP TOP

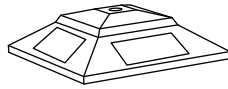

Part ② LIGHT CAP
(battery included)



Part ③ LIGHT BULB
(1 spare bulb included)

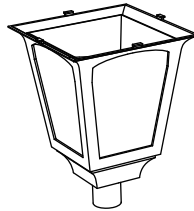

Part ④ LAMPSHADE



Part A × 1



Part B × 3



Part C × 1



Part D × 8
(2 for Spare)



Part E × 4
(2 for Spare)



Part F × 4
(4 for Spare)

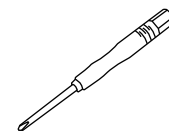

Part G × 1



Part H × 1
(1 for Spare)



Part ⑤ BASE

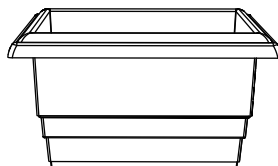

Part ⑥ UPPER PLANTER

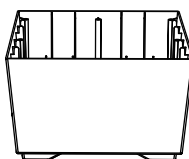

Part ⑦ LOWER PLANTER

Important: Please double check the contents before discarding the package to prevent losing parts which are needed for assembly.

1. How your solar post light works?

During Day, the solar panel converts sunlight into electricity and charge the battery. At night, The light turns on automatically by sensor. The number of hours the light stays on depends on your location, weather and seasonal sunlight availability. Place it in an area where it can receive direct sunlight all day. Shadowed location will not allow the battery to charge fully and will reduce the lighting time. Selected location should not be near bright light, such as porch light, street light. As these may cause the solar light to turn off prematurely.

2. Installation

Installation of Light Head

Step 1 Installation of bulb (Part ① ② and Part ③)

Insert bulb to hole and rotate bulb

Alignment notch insertion and rotation

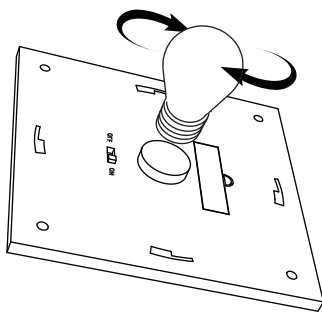

Step 2 Turn On Switch

Turn on switch first time

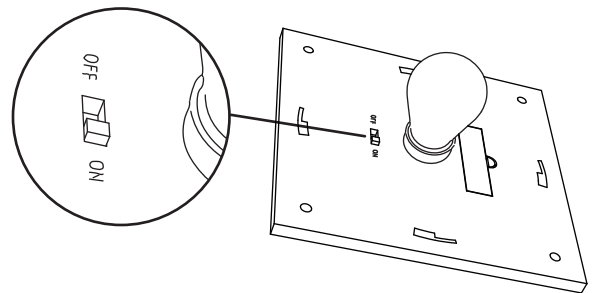

Step 3 Lampshade Assembly (Part ①②③④)

Rotate the cap top downward to install it onto the light cap
Rotate the light cap counterclockwise to install it onto the lampshade

Turn counterclockwise to fix light cap

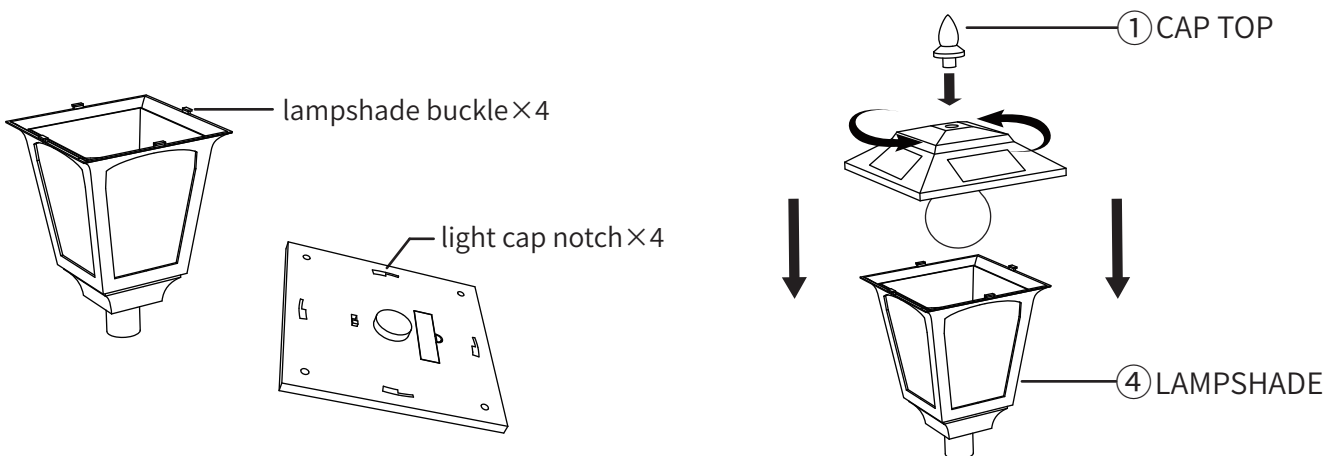

Installation of lamp

Step 1 Base Assembly (Part ⑤ and Part ⑦)

Align the holes, then use the magnetic tip of Screwdriver G to drive Screws E into place.

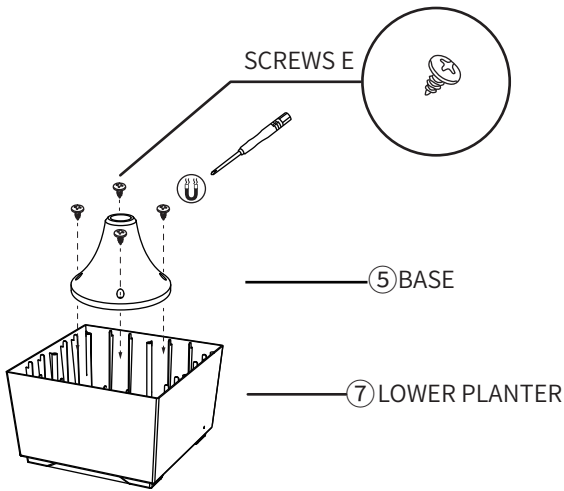

Step 2 Planter Assembly (Part ⑥ and Part ⑦)

Align the 8 screw holes in the upper and lower planter. Then fix it by screws D and Screwdriver G.

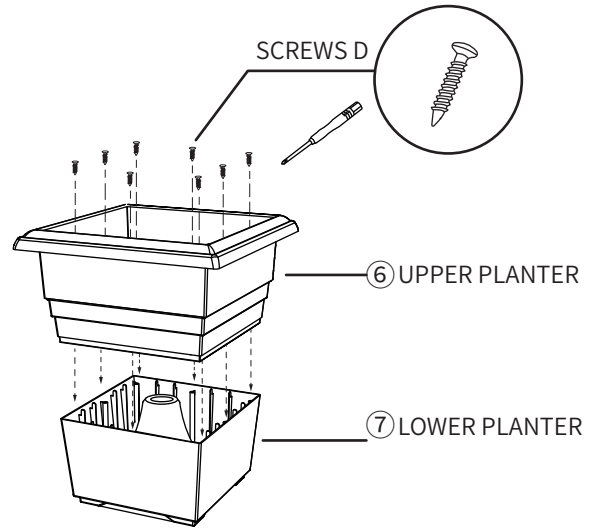

Step 3 Pole and Lamp Assembly (Part ①②③④⑤⑥⑦ and Part ABC)

Here are 3 types of light poles, please choose correctly when installing.

The number of part B installations is determined by demand, and installing different quantities can achieve different product heights.

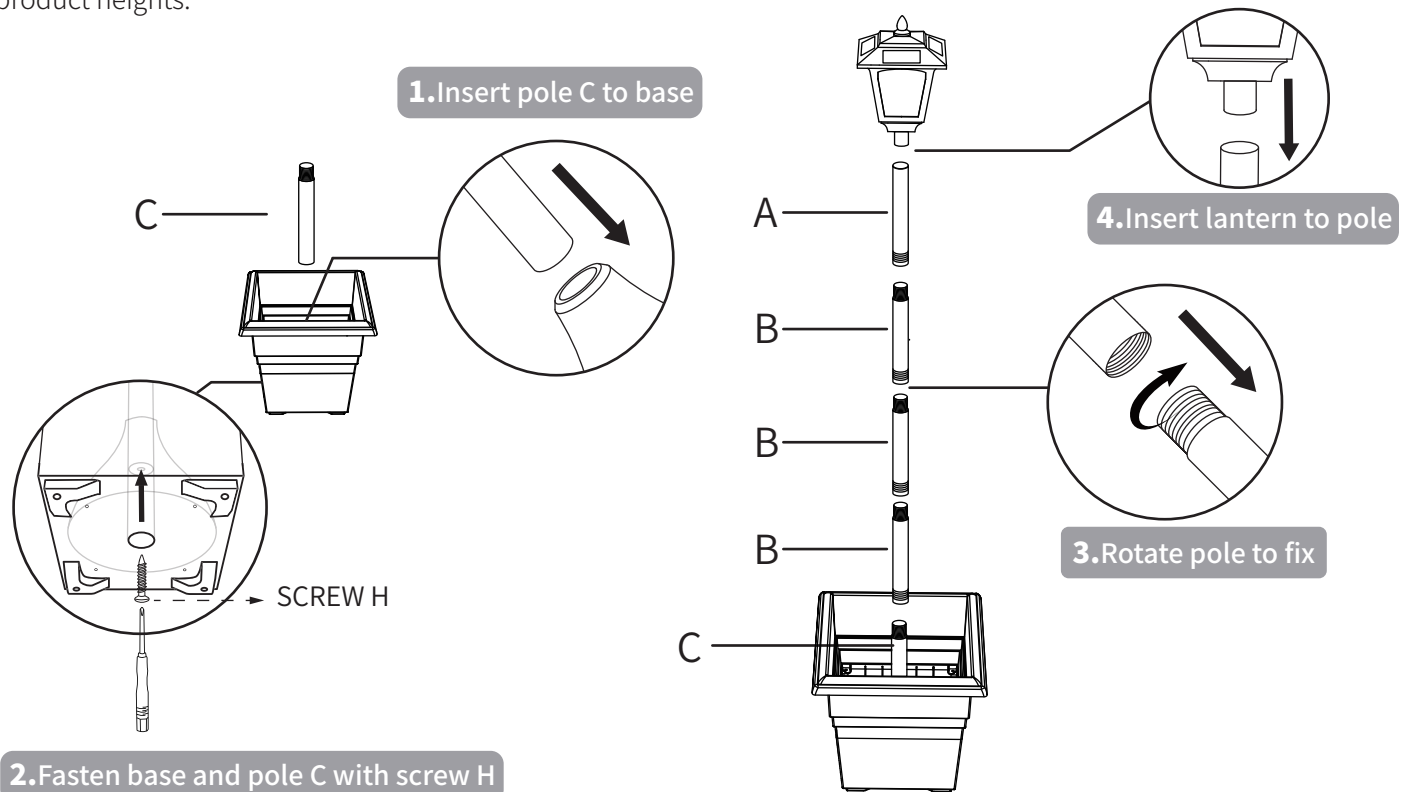

Placement & Stability Guide

This planter is designed for various environments. Choose the setup that best fits your space:

Option A: On Hard Surfaces (Concrete, Patio, or Decks)

For maximum stability on hard ground:

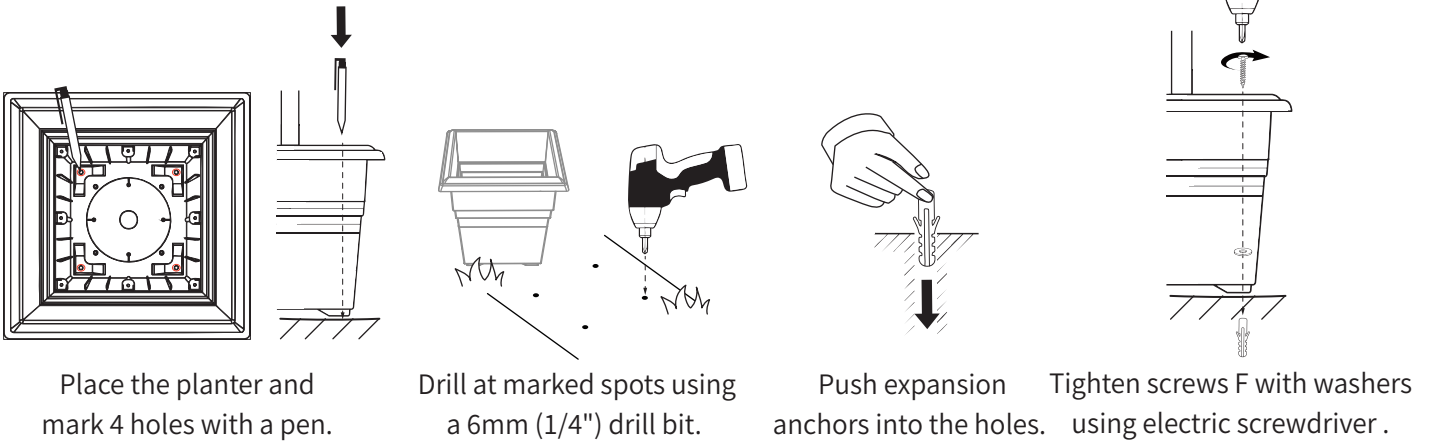

Option B: Free-Standing (Direct Placement)

To enhance stability, please use the recommended layered filling as shown below.

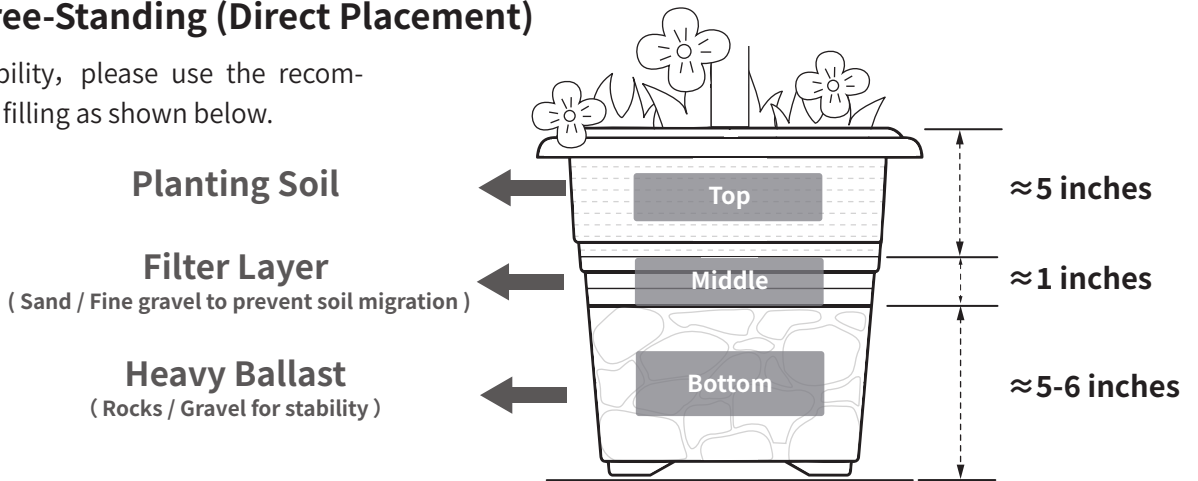

IMPORTANT – Before First Use:

- Turn the switch to “ON”.
- After installation, place the light in direct sunlight for 8–10 hours to fully charge the battery.

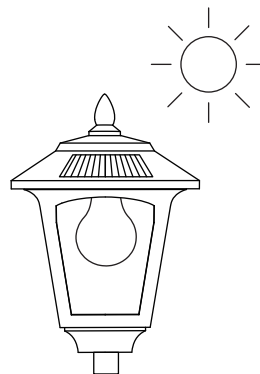

3. Bulb Replacement

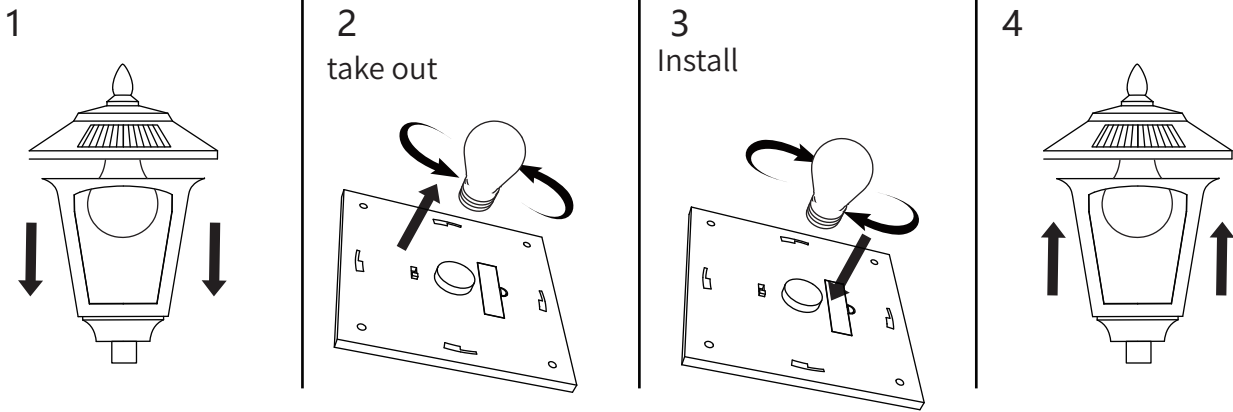

4. Caution For Our Lantern:

- 1.Solar panel must receive the direct sunlight. Ensure that the solar panel is in a bright sunny location. Do not be covered by obstructions like eaves, trees, cars, parasols.
- 2.Make sure the switch is in the “ON” position before charging.
- 3.No ambient light on solar panel at night. If not, the light may turn off.
- 4.The bad weather day may affect the efficiency of charging and reduce the hours of nighttime lighting, like cloudy day or rainy days. If strong storm approaches, we suggest that you do not place the product outdoors.
- 5.Keep the solar panel clean when winter comes, it may have snow or frost covered on it.
- 6.Make sure the battery fits tightly to the terminal.

THANK YOU FOR SHOPPING WITH US!

If you have any questions, or need assistance with use, parts, or customer service.

Please contact RESOULPA@gmail.com
Or text us messages at **(888)788-9454**.

To help us identify your order, please include your Order #. Our professional team will be there to assist you.

Customer Service Team

VIP CUSTOMER SERVICE

Please sign up for your Exclusive Customer Service within 7 days to receive the professional service from one of our best agents.

Text "VIP" to **(888)788-9454** Toll Free

Visit Our Brand Store on Amazon
for More Amazing Products!