

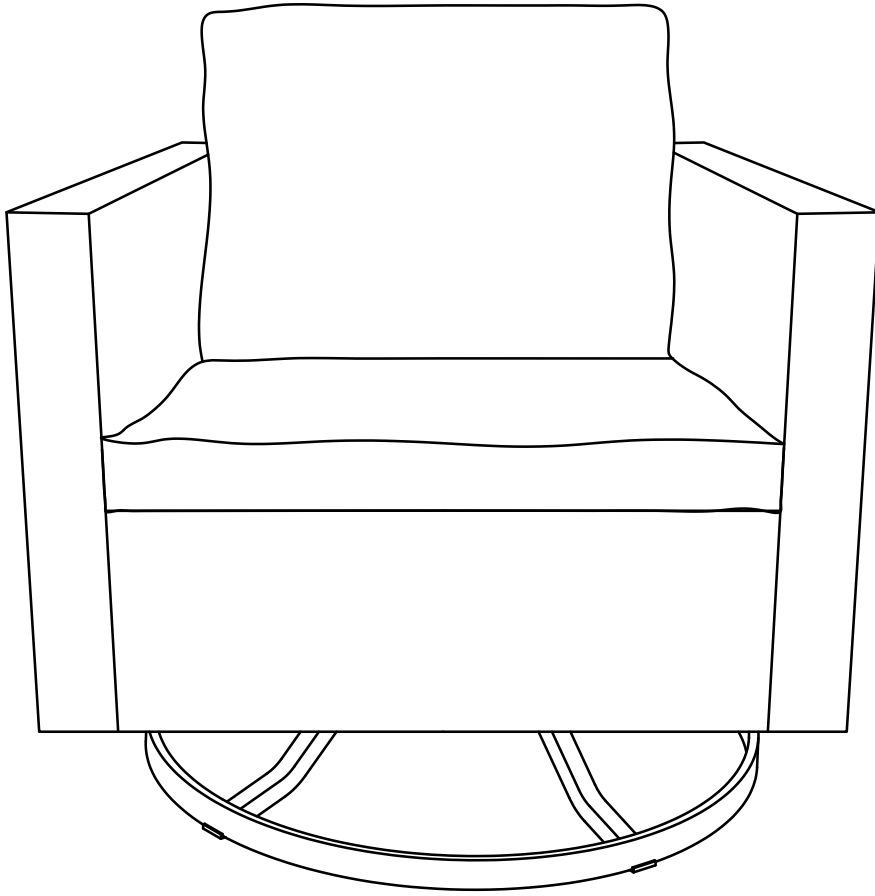







Assembly Instructions

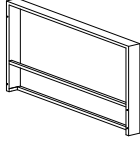
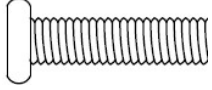
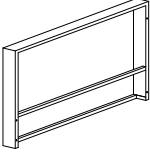
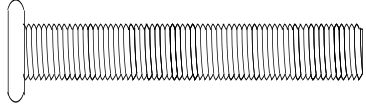
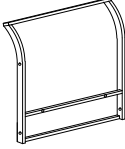

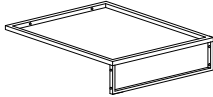
***Don't fully tighten all the bolts till the very end!**

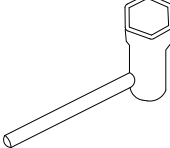

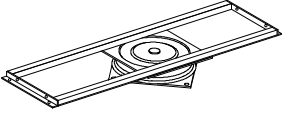
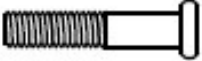
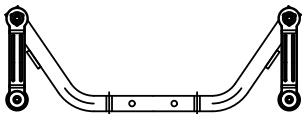
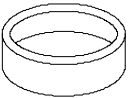
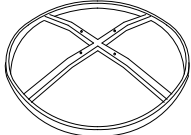
PRE-ASSEMBLY PREPARATION:

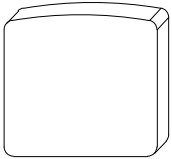
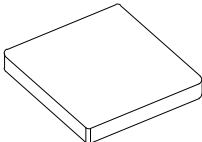
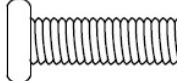
- Please read through the instructions before beginning assembly.
- Clear out the space for assembly and lay out all of the parts based on the Parts List, extra room will allow you to easily determine if all the pieces are present.
- Keep small parts and pieces away from children until fully assembled.

Part no.	Part	QTY	Image	Part no.	Part	QTY	Image
A1	Left arm	1		K	Bolt (M6*40mm)	14	
A2	Right arm	1		L	Bolt (M6*95mm)	2	
B	Back	1		M	Washer M6	34	
C	Seat	1		N	Spring washer M6	16	
D	Wrench	1		O	Nut M6	12	
E	Swivel plate with support bar	1		P	Bolt (M6*30mm)	4	
F	U-shape fitting	2		Q	Bolt cap	2	
G	Base	1		R	Allen wrench	1	
H	Back cushion	1					
I	Seat cushion	1					
J	Bolt (M6*35mm)	6					

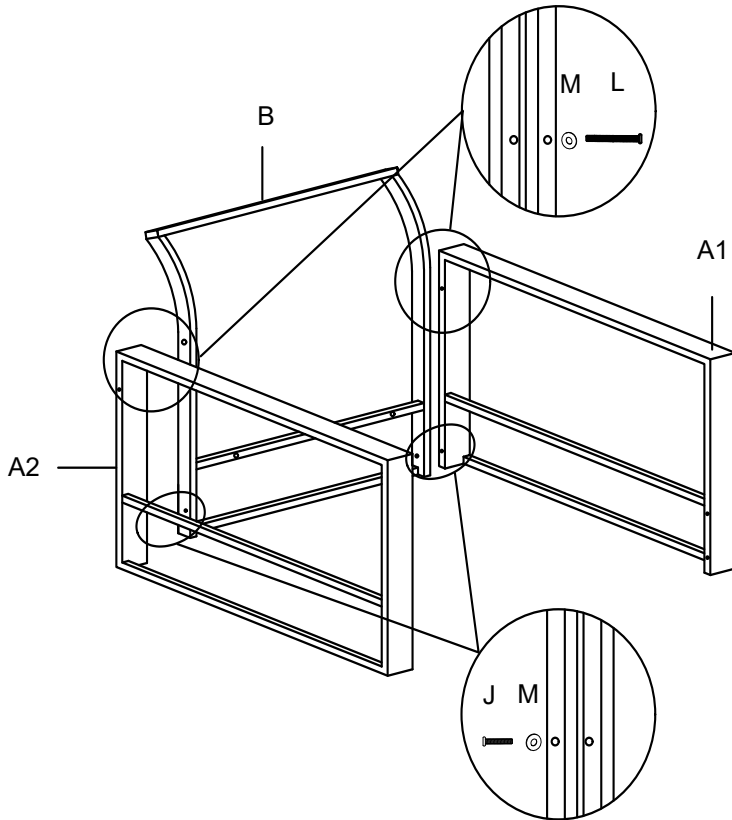

Step 1: Attach back B to arms A1 & A2 with 2pcs bolts L, 2pcs bolts J and 4pcs washers M, using Allen wrench R. Note: Don't fully tighten the bolts.

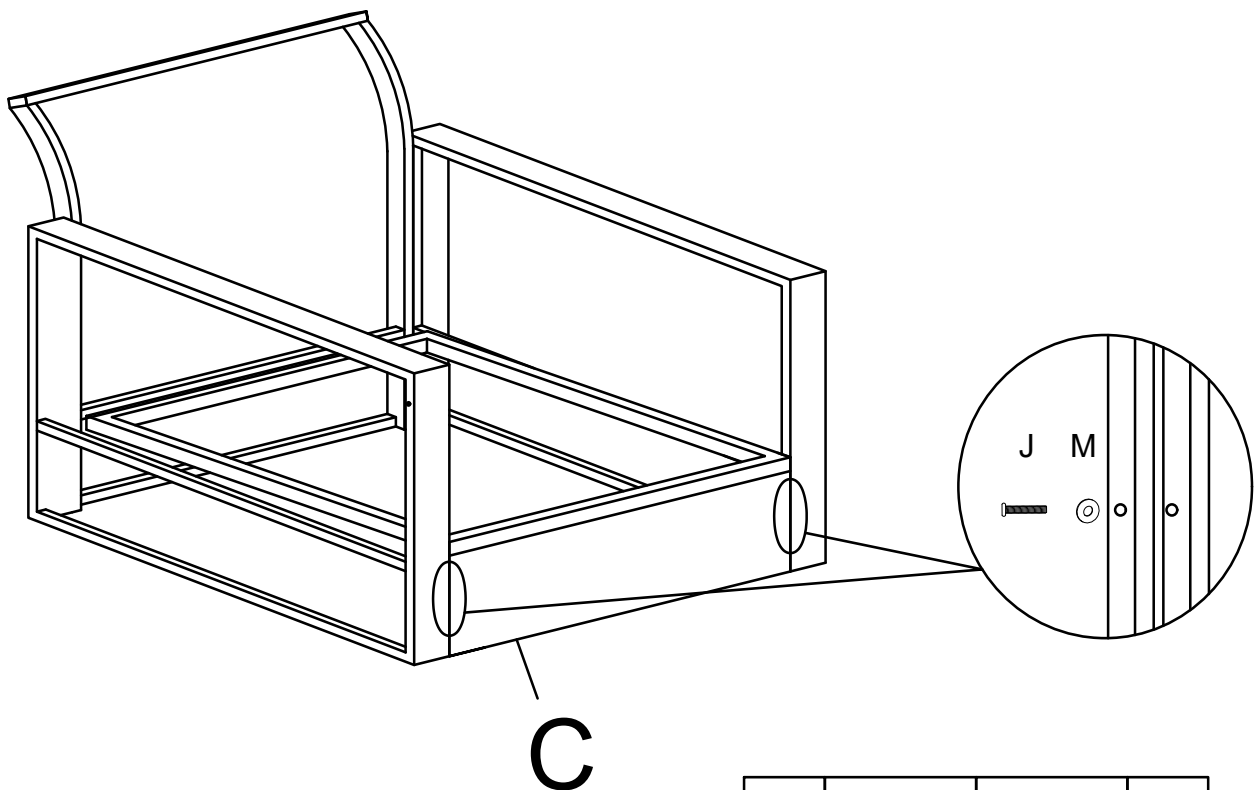

L		M6*95	2
J		M6*35	2
M		Ø16*Ø6.5*1	4

Step 2: Attach seat C to arms A1 & A2 with 4pcs bolts J and 4pcs washers M, using Allen wrench R. Note: Don't fully tighten the bolts.



J		M6*35	4
M		Ø16*Ø6.5*1	4



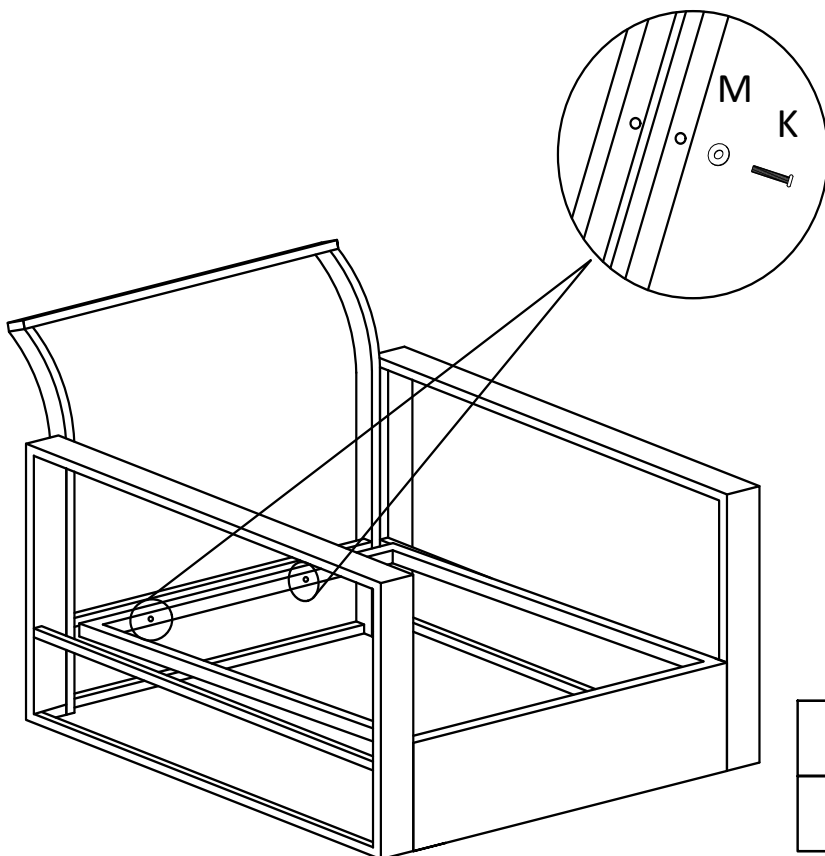

Step 3: Attach seat C to back B with 2pcs bolts K and 2pcs washers M, using Allen wrench R. Note: Don't fully tighten the bolts.

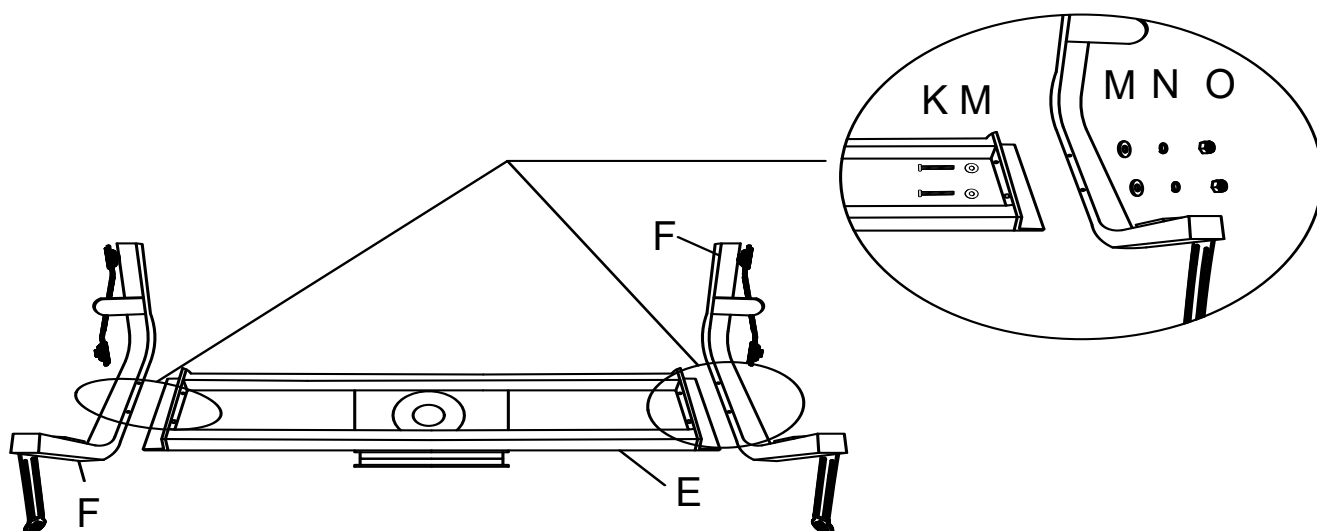

K		M6*40	2
M		Ø16*Ø6.5*	2

Step 4: From horizontal direction, attach 2pcs part F to part E with 4pcs bolts K, 8pcs washers M, 4pcs spring washers N, and 4pcs nuts O, using Allen wrench R and wrench D. Note: Don't fully tighten the bolts.



K		M6*40	4
M		Ø16*Ø6.5*1	8
N		M6	4
O		M6	4



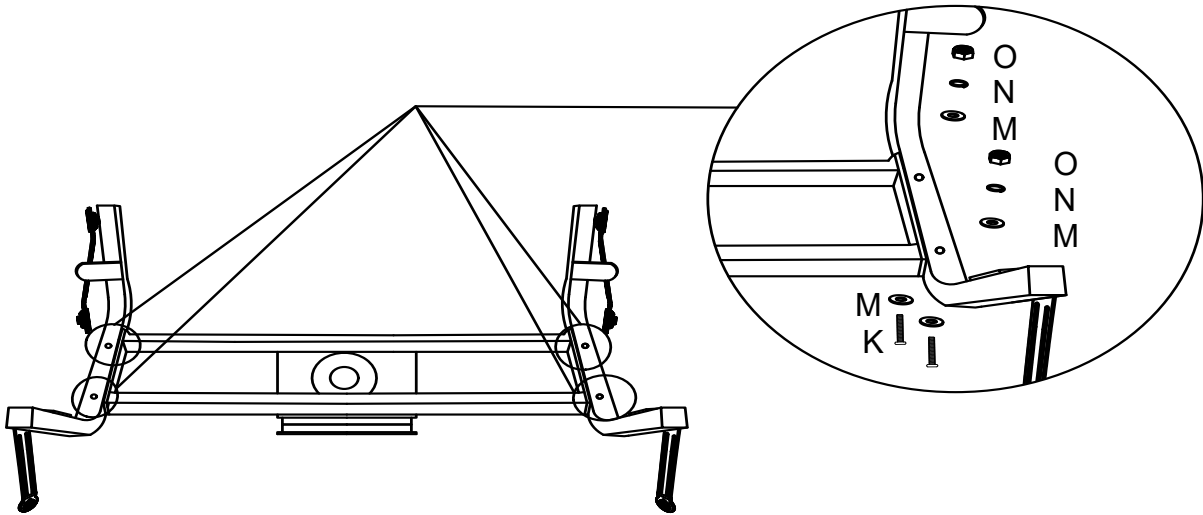

Step 5: From vertical direction, attach 2pcs part F to part E with 4pcs bolts K, 8pcs washers M, 4pcs spring washers N, and 4pcs nuts O, using Allen wrench R and wrench D. Note: Don't fully tighten the bolts.

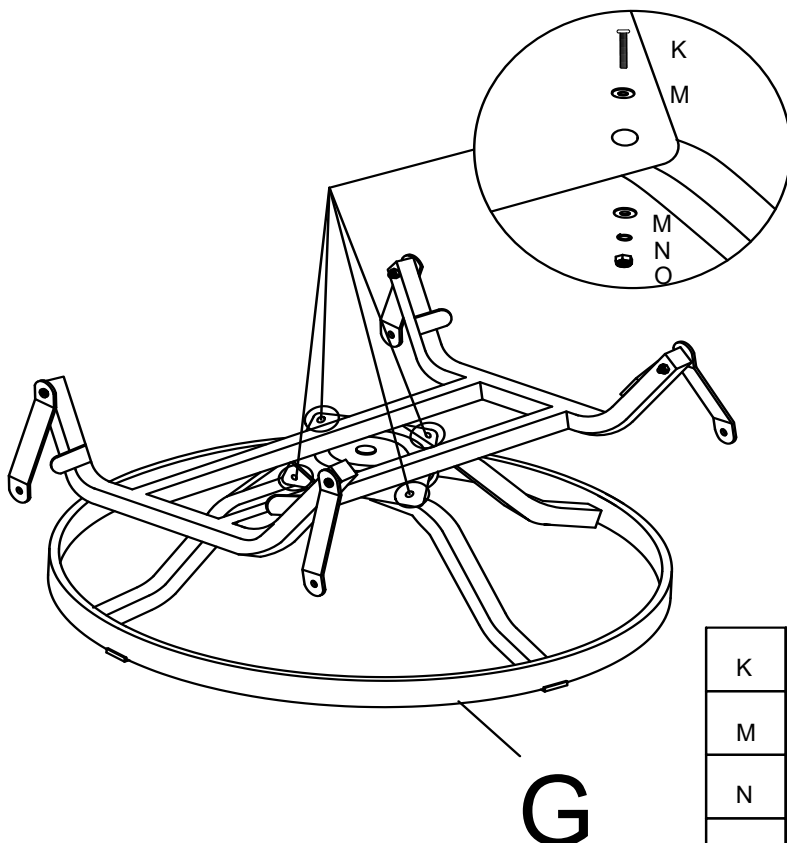

K		M6*40	4
M		Ø16*Ø6.5*1	8
N		M6	4
O		M6	4



Step 6: Attach swivel plate to part G with 4pcs bolts K, 8pcs washers M, 4pcs spring washers N, and 4pcs nuts O, using Allen wrench R and wrench D. Note: Don't fully tighten the bolts.

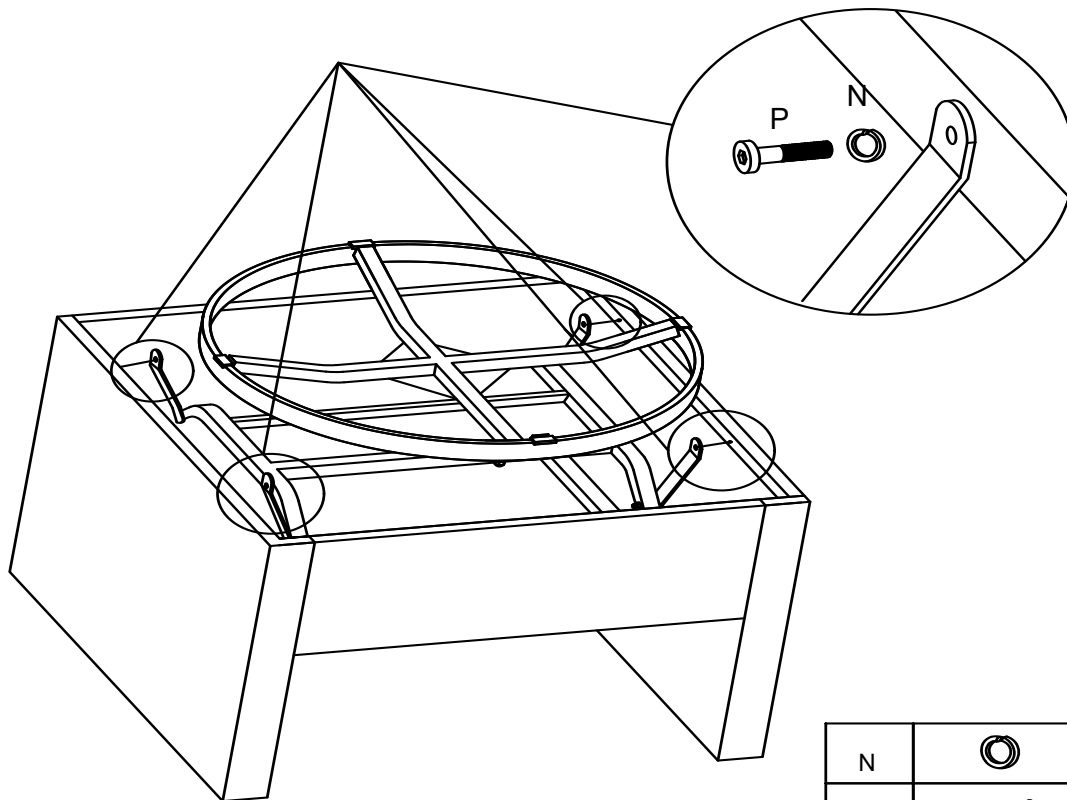

K		M6*40	4
M		Ø16*Ø6.5*1	8
N		M6	4
O		M6	4

Step 7: Attach swing arms to arms A1&A2 with 4pcs bolts P and 4pcs spring washers N, using Allen wrench R. Note: Please fully tighten all the bolts.



N		M6	4
P		φ9.5*30*M6	4

Step 8: Lock 2pcs bolt caps Q to arms A1 & A2.

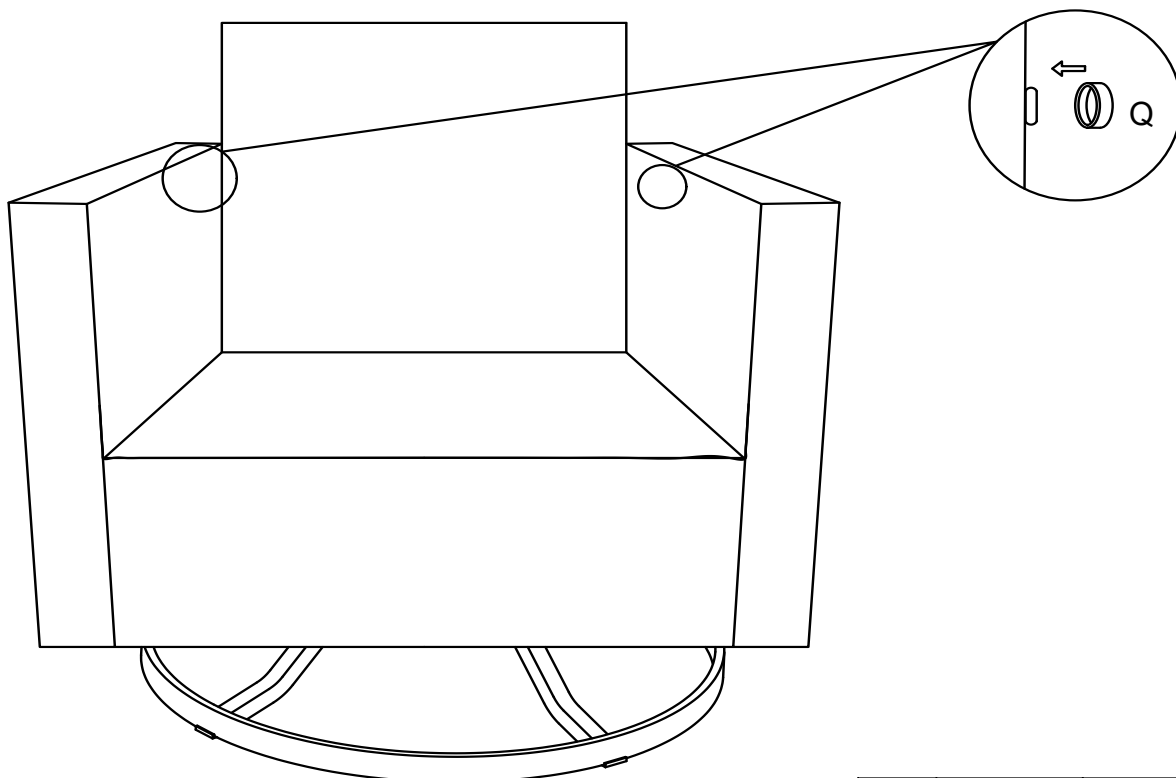

Q		plastic cap	2
---	---	-------------	---

Step 9: Put back cushion H and seat cushion I onto the seat . Assembly is now complete and the product is ready for use.

