

USER'S MANUAL

KITCHEN & DINING ROOM BENCHES

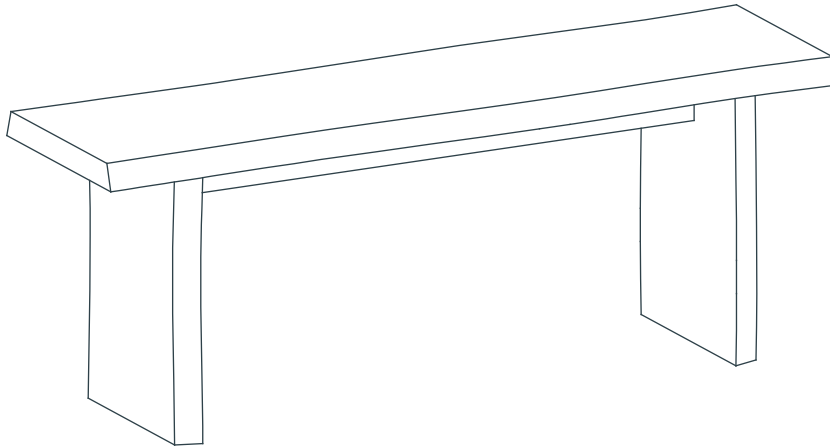

Guide of Manual

- ★ Thanks for your choice. **We will do our best to provide customer service for everyone.**
- ★ Please check to make sure all parts are included as stated when you unpack. If there are parts missing or wrong, please contact us, **we will expeditiously provide reissue accessories, compensation or other services.**
- ★ Instruction should be read carefully. But the manual may not cover every detail of all possible situations and steps. **Please contact us if further information and help are needed. We will respond in a timely manner.**
- ★ Please be patient that the other items are on the way if you buy more than one product.

Warning

- It's kindly advised to assemble this product on a carpeted floor to protect it from being scratched.
- Small parts are included. Please keep the product away from children while assembling. Do not let children play or jump on the product. Do not stand on the item or use as a step ladder.
- Please pay attention to the sharp corners during assembly. We recommend the use of gloves to prevent the undesired injury.
- Prior to use, please check to see if there's any loosening screw or part. Make sure that each screw and part is correctly installed and securely fastened.
- Usually it's unnecessary to use electric drill. Please at a low gear if you need.

Care and Maintenance

- It is normal that metal product will scratch stainless steel easily. To keep good condition of product, please try to avoid use metal product on it.
- Liquid should be removed gently with a soft clean cloth to avoid rubbing.
- Clean the surface of stainless steel with water in daily life, use detergent if needed, please keep the stainless steel surface dry after cleaning. Bleach as well as grinding detergent, stainless steel sponges scrubbers and abrasive tools should be avoided.

Further Advice About The Furniture Care



- It is best to keep your furniture in a climate-controlled environment.
- If not used for a long time, please place the furniture away from sunlight exposure or use a cover to protect it.
- Proper maintenance and cleaning at home will extend the life of your purchase.
- Following these important and helpful tips will help retain your furniture's performance even when it ages.
- Periodically (every 90 days) make sure the screws are fully tightened.

**⚠ MAX WEIGHT CAPACITY: 450LBS
DO NOT STAND ON THE ITEM**



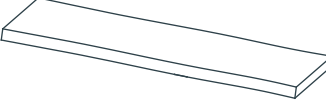

Parts List & Assembly Instruction

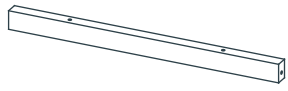
1. Make sure all parts are in the package.
2. "+" in below list indicates that additional pieces are replacement parts.
3. Do not fully tighten anything until all screws, nuts, washers and bolts are in place.

Parts List

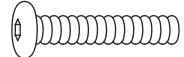
<p>① x1pc Panel</p> 	<p>② x2pcs Legs</p> 	<p>③ x1pc Supporting Rod</p> 
---	---	---

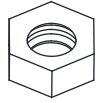
Hardware List

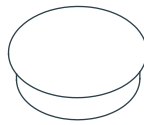
<p>④ x4+1pc</p>  <p>M8*70mm</p>	<p>⑤ x4+1pc</p>  <p>M8*50mm</p>	<p>⑥ x4+1pc</p> 	<p>⑦ x4+1pc</p>  <p>M8</p>
<p>⑧ x1pc</p> 	<p>⑨ x1pc</p> 	<p>⑩ x4pcs</p> 	

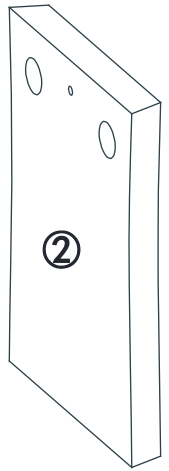
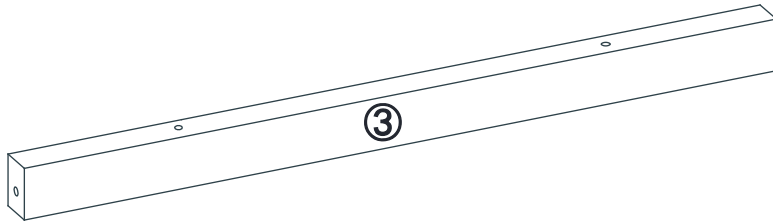
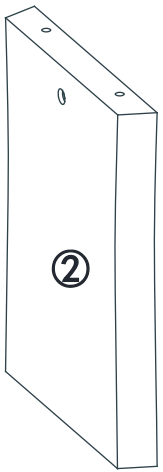
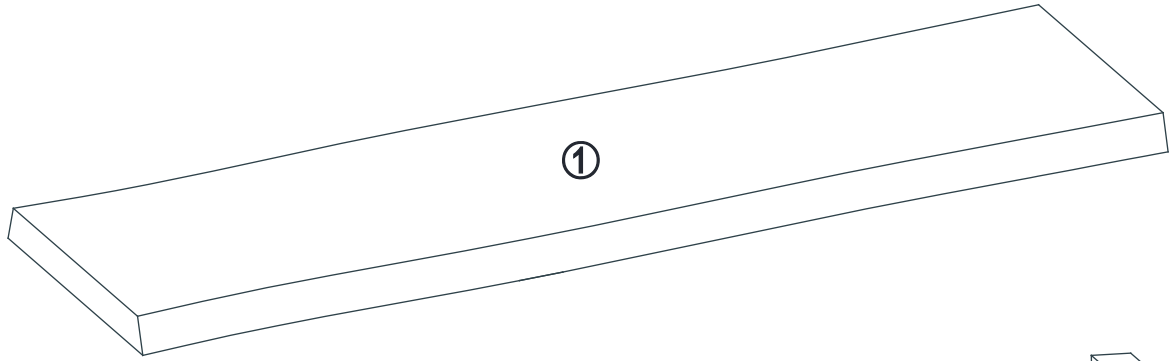

Step 1

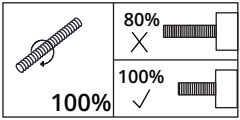
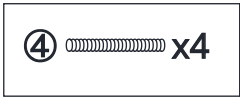

Tighten the screws ④ to 100% in Step 1.
Then put the legs ② onto the panel ①
through the screws ④.

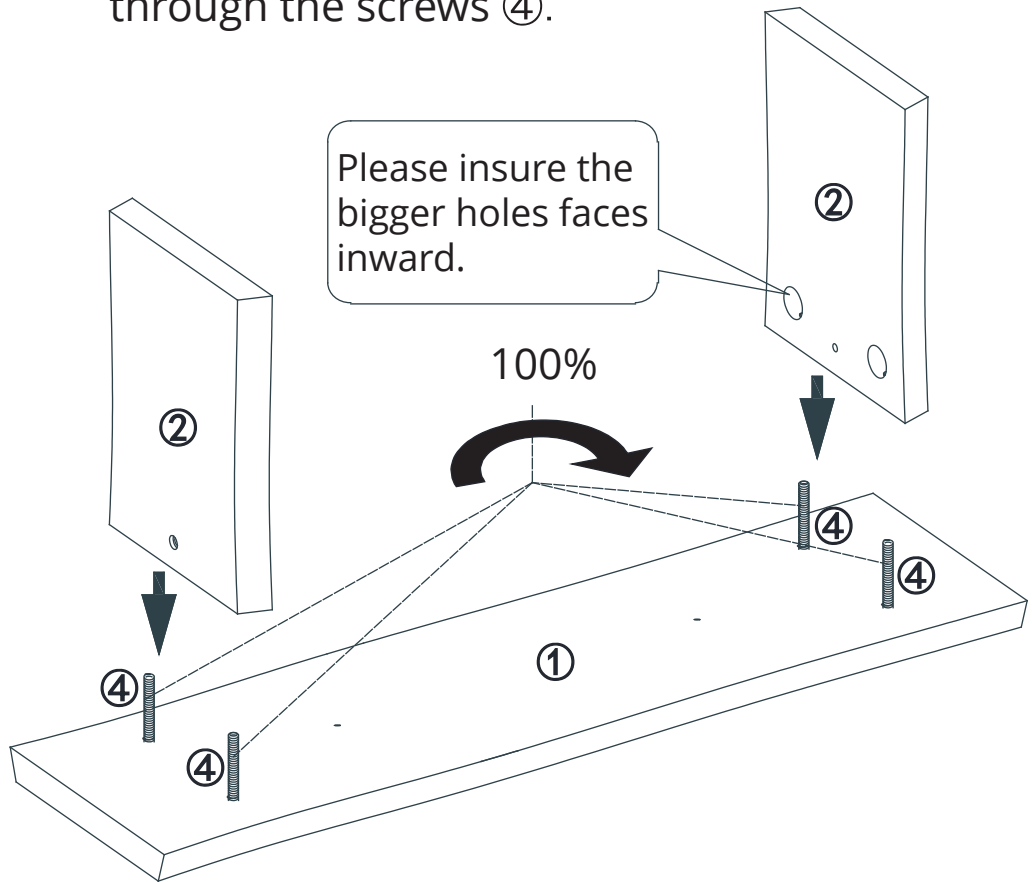

Step 2

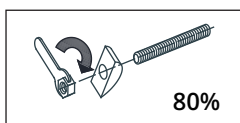

Tighten the nuts ⑦ to 80% in Step 2.

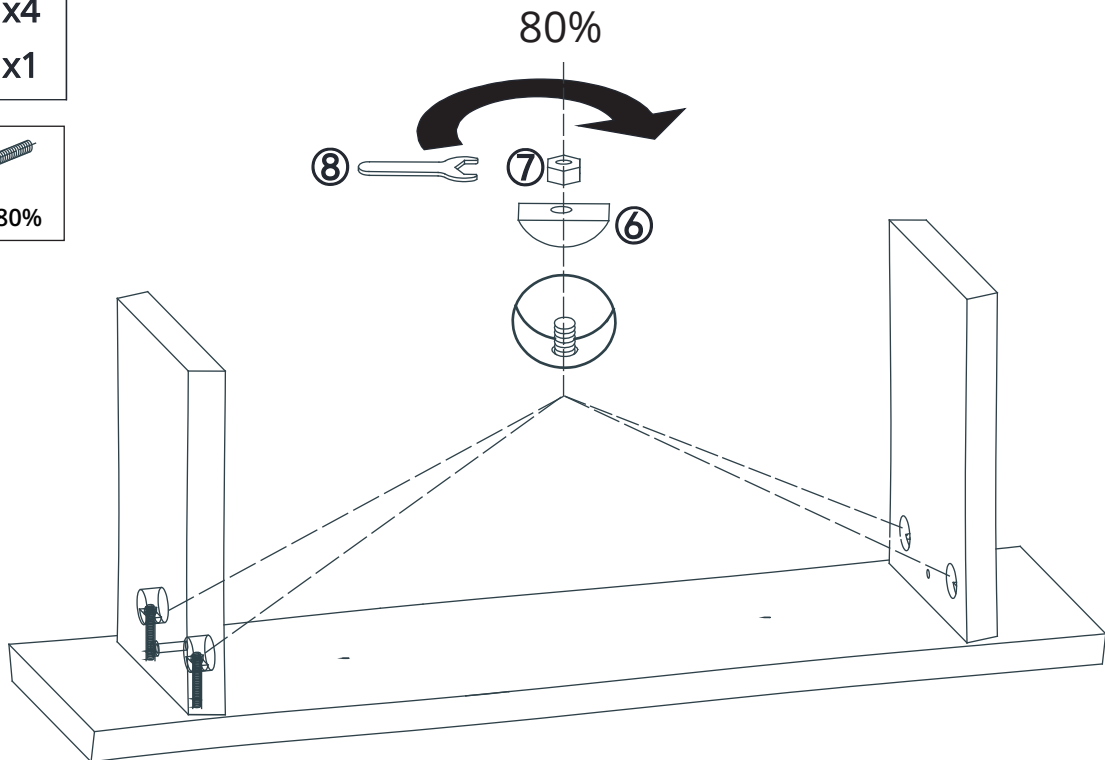

Step3

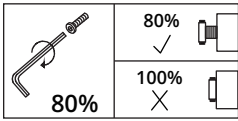
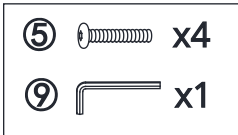

Tighten the screws ⑤ to 80% in Step 3.

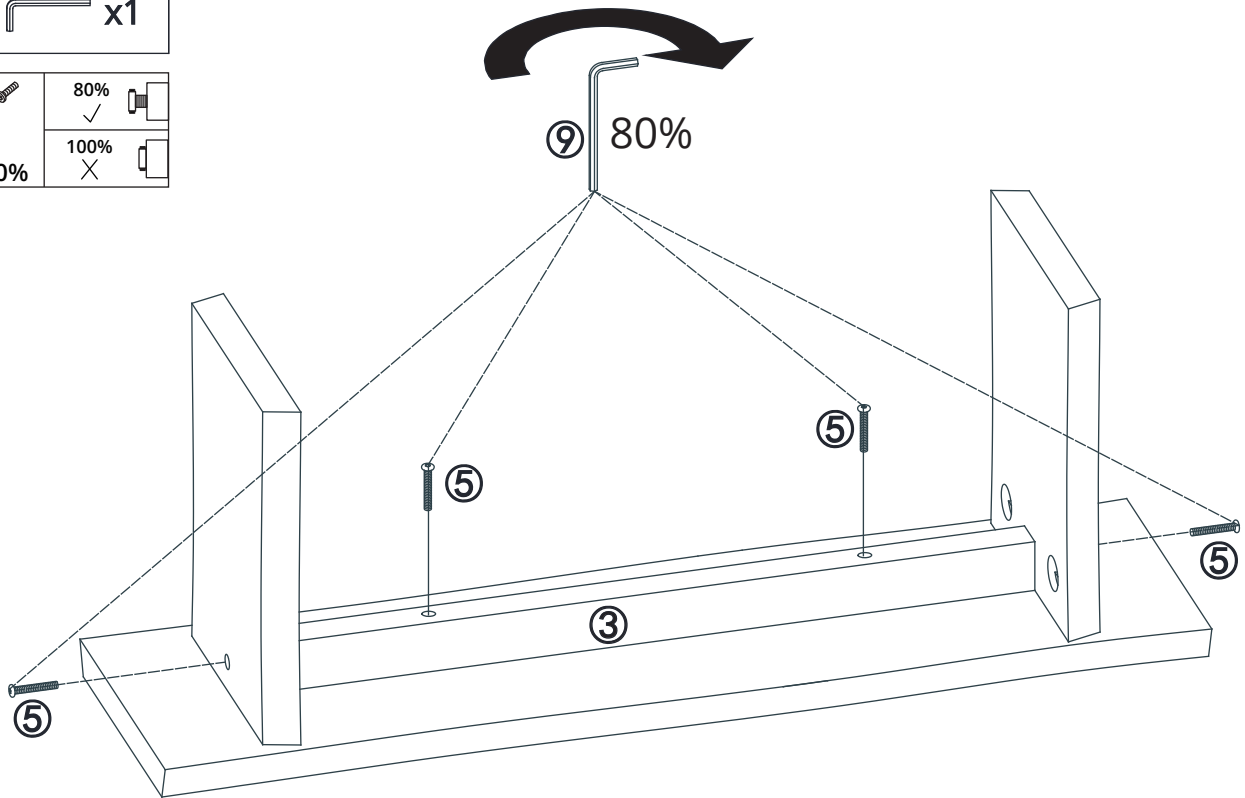

Step4

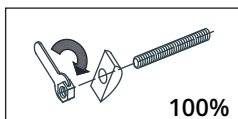

In Step 4, tighten all the nuts ⑦ mentioned in Step 2 to 100%.

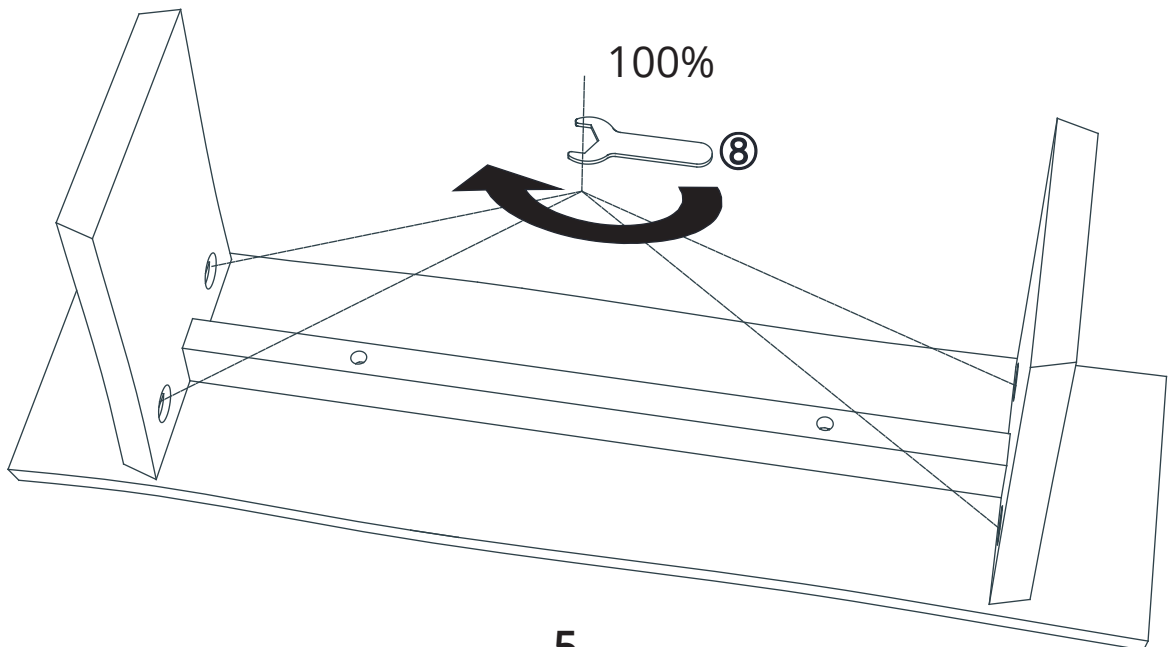

Step 5

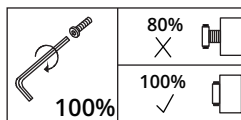
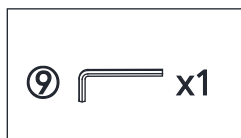

In Step 5, tighten all the screws mentioned in Step 3 to 100%.

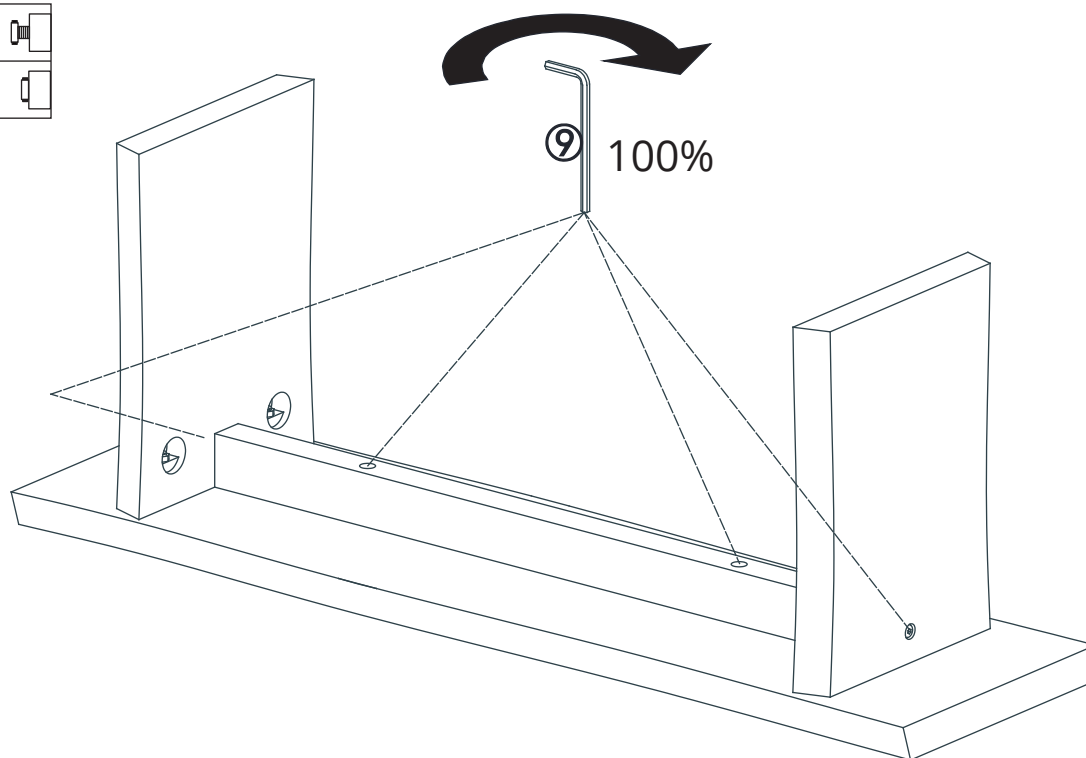

Step 6

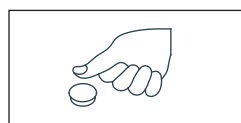

Please ensure that the stool is stable and without any problems before pressing the cover ⑩ into the holes in Step 6.

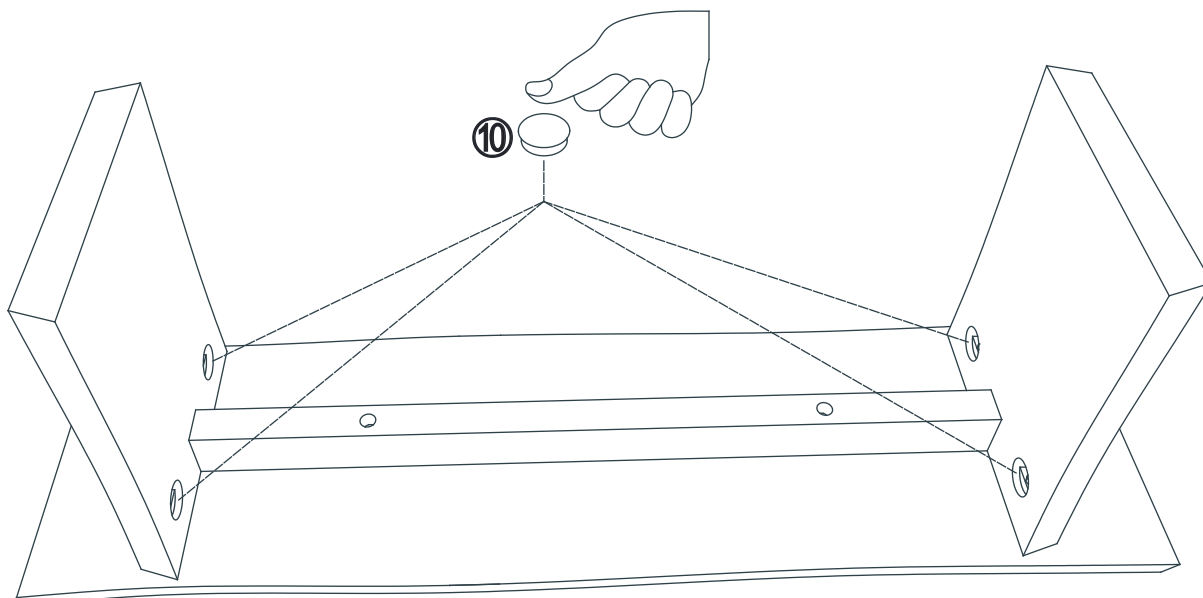

FINISHED

