

Electric Flip Down Ceiling TV Mount

MOUNT-E-FD75C

Assembly Manual

[THIS PAGE HAS BEEN INTENTIONALLY LEFT BLANK]

**** DO NOT RETURN ITEM ****

Contact Us First!

Our friendly US-Based Product Support Team to help!



We're Here For You

Monday-Friday from 7am-7pm CST
Saturday 8am-4pm CST

US-Based Customer Support from Trained Professionals



Email Us

help@vivo-us.com



Chat with Live Agent

www.vivo-us.com



Give Us a Call

309-278-5303 ext. 1

Assembly Video Available

Navigate to the middle of the product page to watch as our product specialists walk you through the assembly process.

www.vivo-us.com/products/mount-e-fd75c



WATCH NOW

[THIS PAGE HAS BEEN INTENTIONALLY LEFT BLANK]

User Guide

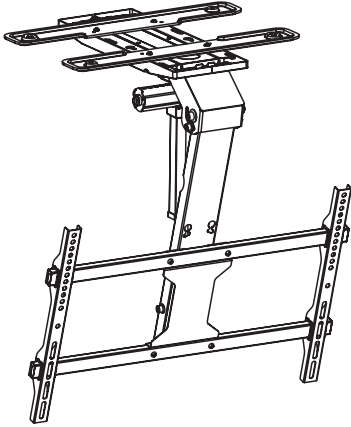

Assembly & Installation

pg.9-23

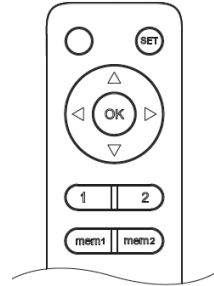

Remote Setup & Use

pg.24-27



Tuya App Setup & Use

pg.29-37



Amazon Alexa & Google Home Voice Controls

pg.25-27



PLEASE READ



General Notice:

If you do not understand these directions, or if you have any doubts about the safety of the installation, please contact our product support team at 309-278-5303 or help@vivo-us.com for further assistance. Check carefully to make sure there are no missing or defective parts. Improper installation may cause damage or serious injury. Do not use this product for any purpose that is not explicitly specified in this manual. Do not exceed weight capacity. We cannot be liable for damage or injury caused by improper mounting, incorrect assembly or inappropriate use.

Missing Parts:

If any parts are received damaged / defective OR you are missing a part, please reach out to us **within 30 days of product delivery to have it replaced at no cost. PLEASE NOTE:** Failure to report missing parts within the stated time frame may result in denial of free replacement.

Returns:

We offer a hassle-free 30 day return on all products. Contact customer support at 309-278-5303 or help@vivo-us.com. Please note: For items ordered in error or no longer needed, the return shipping charges will be at the buyer's expense.

Product Specific Warnings:



WARNING: CHOKING HAZARD

SMALL PARTS - NOT FOR CHILDREN UNDER 3 YEARS. ADULT SUPERVISION IS REQUIRED.



DO NOT EXCEED WEIGHT CAPACITY

FAILURE TO DO SO MAY RESULT IN SERIOUS INJURY.



**99lbs
(45kg)**



WARNING: DO NOT INSTALL INTO DRYWALL ALONE

VERIFY YOUR WALL CONSTRUCTION. USE WOOD STUDS TO MOUNT. We include mounting for brick and concrete walls. If unsure, please contact us at vivo-us.com, email at help@vivo-us.com, or call us at 309-278-5303.



WARNING: PINCH POINT

DO NOT PLACE HANDS ON OR NEAR SUPPORT BARS. MOVING PARTS CAN CRUSH AND CUT. FAILURE TO FOLLOW THESE INSTRUCTIONS MAY RESULT IN SERIOUS PERSONAL INJURY.

Package Contents

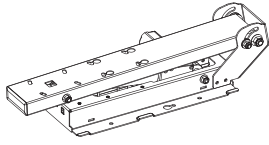

A (x1)
Mount

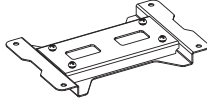

B (x1)
Center Plate

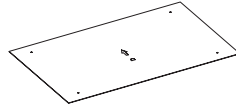

C (x1)
Template

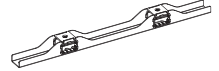

D (x2)
VESA Bracket

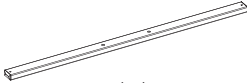

E (x2)
Bracket Rail

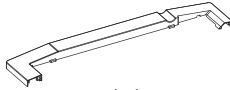

F (x1)
Left Cover

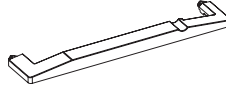

G (x1)
Right Cover



H (x1)
Power Adapter

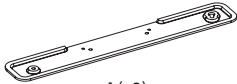

I (x2)
Mounting
Extension

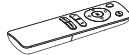

J (x1)
Remote



K (x4)
Cable Tie



L (x3)
Cable Clip

Included Hardware & Tools



S-A (x4)
Set Screw



S-B (x4)
M4x8mm
Screw



S-C (x4)
M6x16mm
Screw



S-D (x4)
M6x25mm
Screw



S-E (x8)
D6 Washer



S-F (x4)
M6 Nut



S-G (x4)
M6 Lock Nut

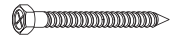

W-A (x4)
ST6.3x55mm
Screw

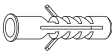

W-B (x4)
Concrete
Anchor



W-C (x2)
D6 Washer



M-A (x4)
M6x14mm
Screw



M-B (x4)
M8x16mm
Screw

Included Hardware & Tools – Con't



M-C (x4)
M6x30mm
Screw

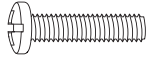

M-D (x4)
M8x35mm
Screw



M-E (x4)
D8 Washer



M-F (x4)
Small Spacer



M-G (x4)
Large Spacer



T-A (x1)
3mm Allen
Wrench



T-B (x1)
4mm Allen
Wrench

Tools Needed:



**Phillips
Screwdriver**



Drill

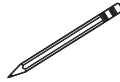

Pencil

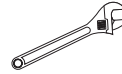

**Adjustable
Wrench**



Ladder



Stud Finder

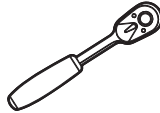

Socket Wrench

Weight Capacity:



Assembly

STEP 1

1. With the Mount (A) flipped on its back, plug the Power Adapter (H) into the back of Mount.
2. Plug the Power Adapter (H) into a power source.

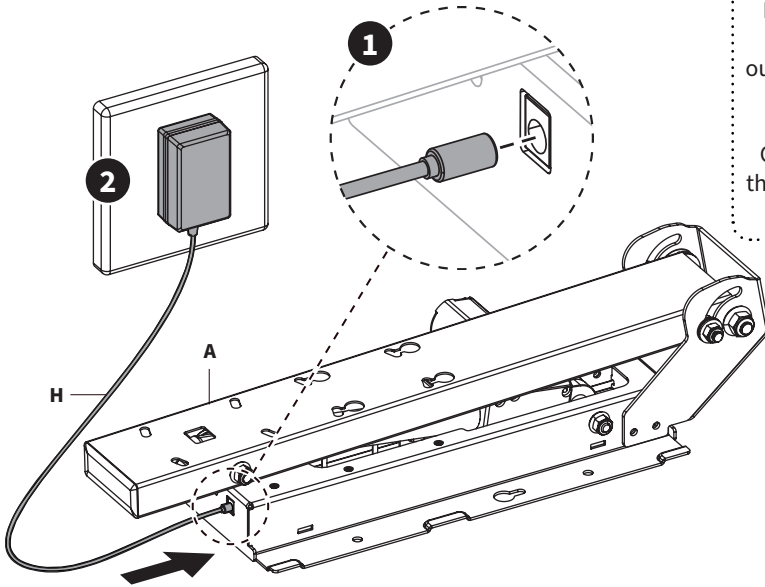

!
Be sure to plug the Power Adapter (H) into a power outlet **AFTER** connecting it to the Mount.
Connecting the Adapter in the wrong order may cause a large spark.

Use Remote (J) to unfold Mount (A). Unplug the Mount.

!
****Warning****
Keep hands clear of moving mount to prevent injury.

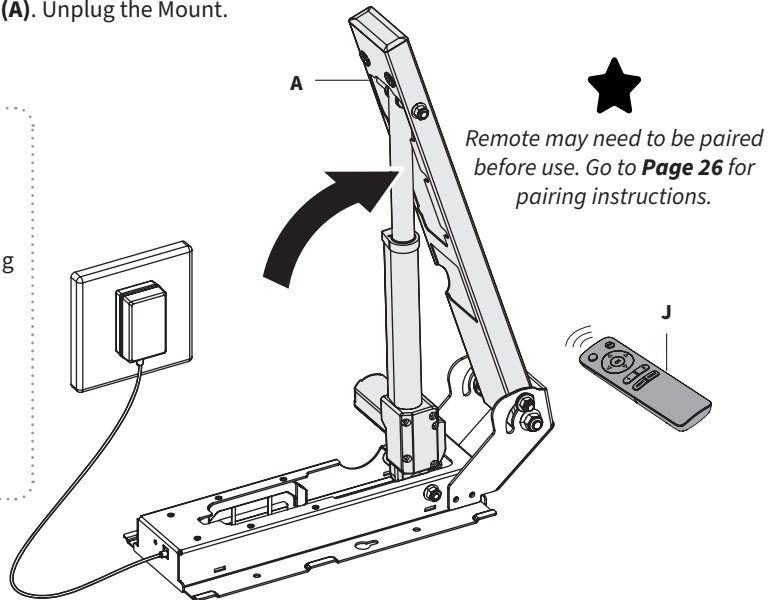

STEP 2

Attach Mounting Extensions (**I**) to Mount (**A**) using M6x16mm Screws (**S-C**), D6 Washers (**S-E**), and M6 Lock Nut (**S-G**). Tighten with 4mm Allen Wrench (**T-B**) and Wrench.

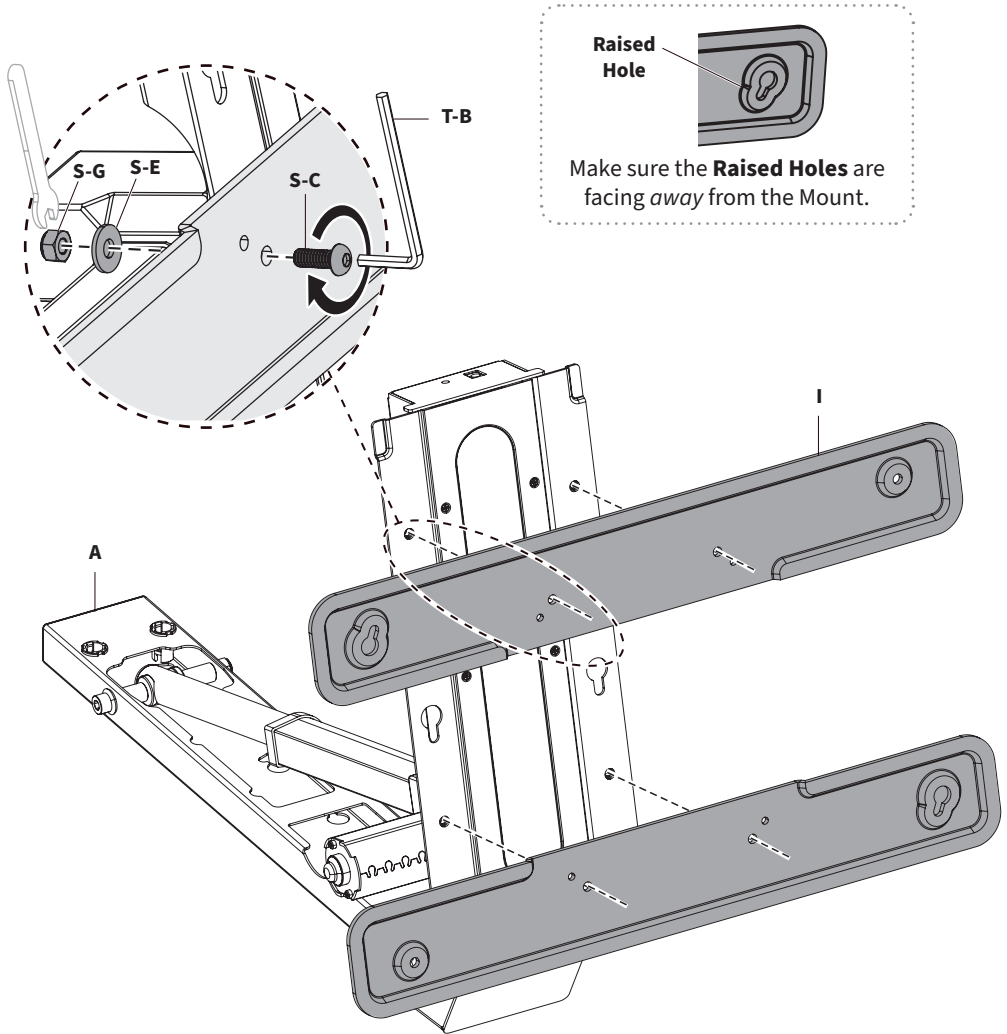

*****Please Read Before Proceeding*****

Mounting Surface Options

Check your mounting surface and choose the corresponding option below.

Option 1:
Wood Joist
Pages 12-13

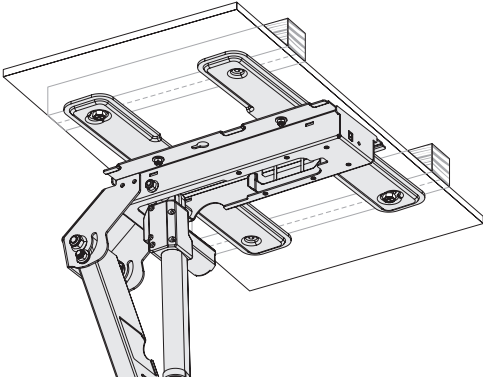

Option 2:
Solid Wood
Pages 14-15

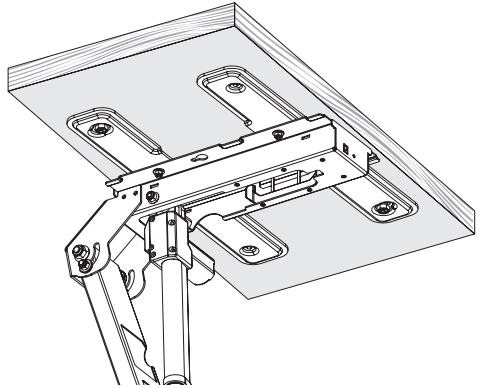

Option 3:
Concrete
Pages 16-17

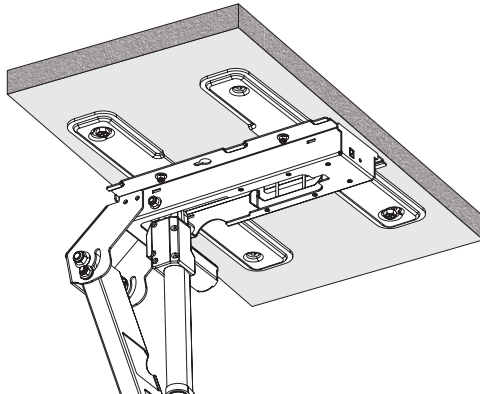

Option 1: Wood Joist Installation

STEP 3

Identify wood joists in ceiling using a stud finder. Position Template (C) as shown and mark holes accordingly.

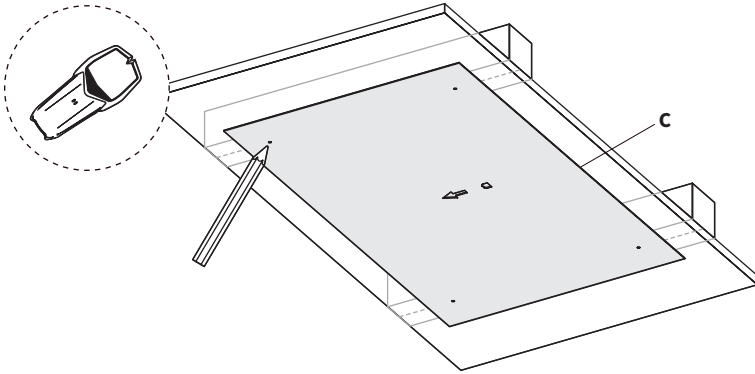

Make sure the arrow on the Template points towards the end that will have your TV.

Pre-Drilling Instructions

Drill mounting holes using infographic below

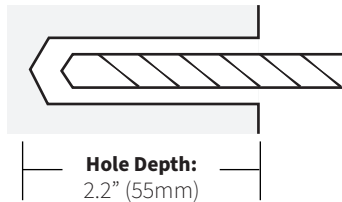

Drill Bit:
3/16" (4.5mm)

Hole Depth:
2.2" (55mm)

Using a socket wrench, insert ST6.3x55mm Screws (W-A) into the mounting holes that align with the **Keyhole Slots** of the Mount Extensions (I), leaving a 3mm gap from the ceiling.

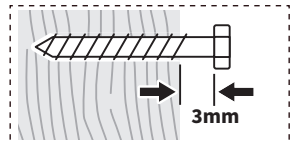
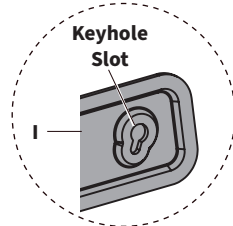
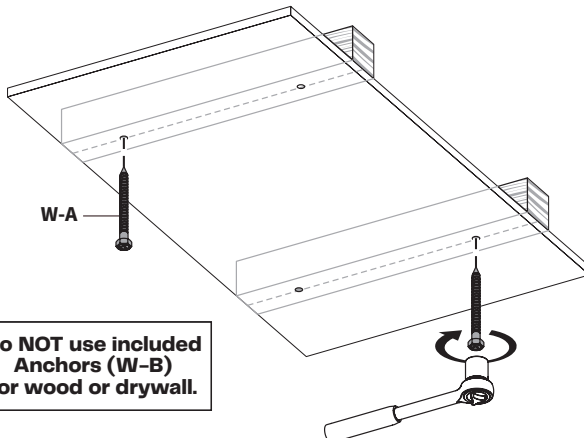

Do NOT use included Anchors (W-B) for wood or drywall.

STEP 4

Raise the Mount Assembly so the ST6.3x55mm Screws (**W-A**) fit through the **Keyhole Slots** of the Mount Extensions (**I**). Turn Mount Assembly until supported by Screws.

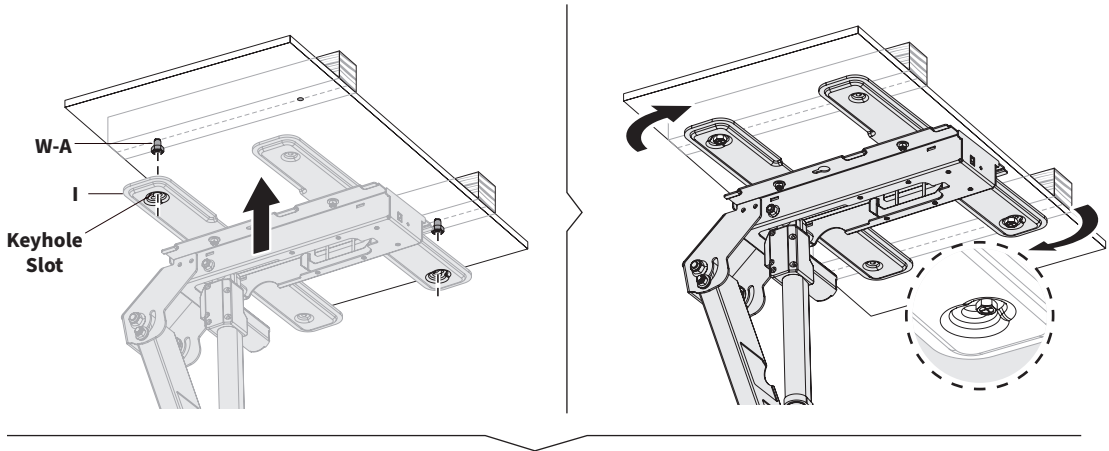

Secure Mount Assembly using the remaining ST6.3x55mm Screws (**W-A**), M6 Washers (**W-C**). Tighten all Screws with a socket wrench.

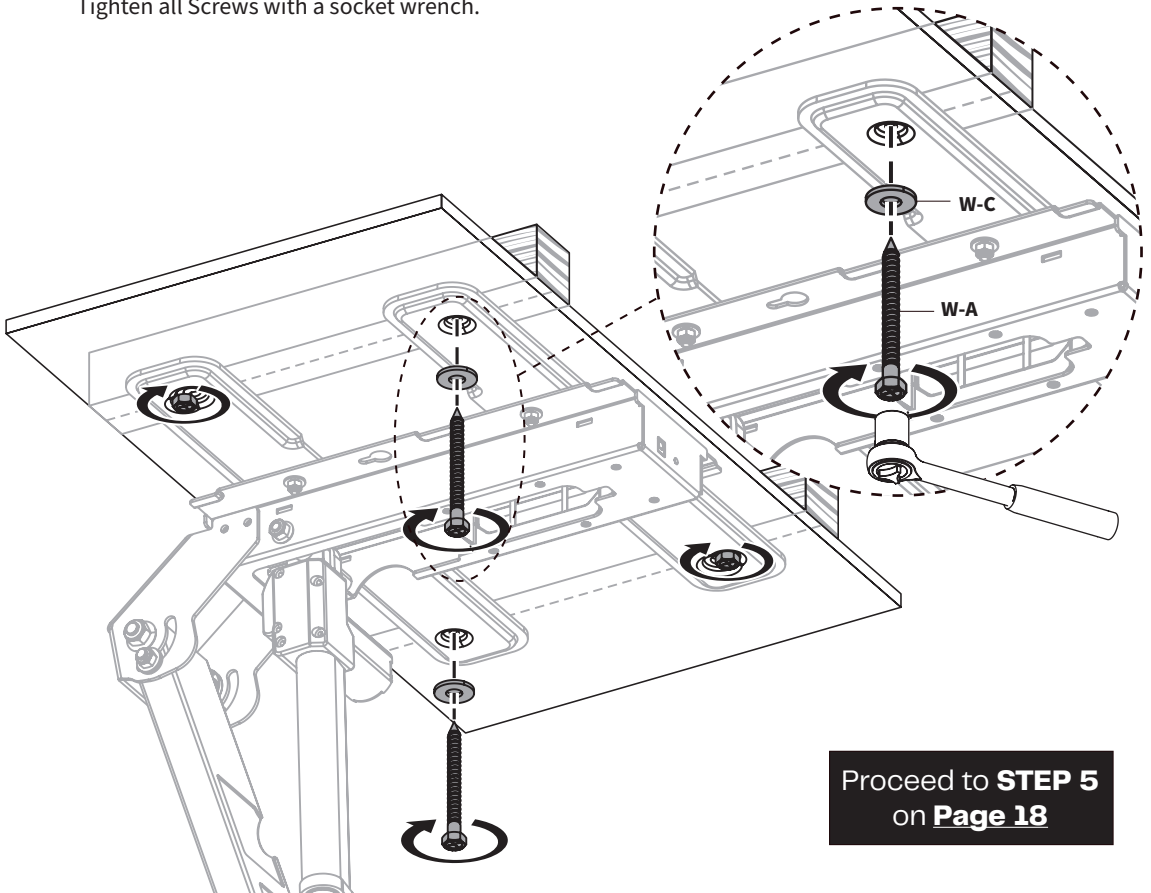

Proceed to **STEP 5**
on **Page 18**

Option 2: Solid Wood Installation

STEP 3

Position Template **(C)** in desired location and mark mounting holes.

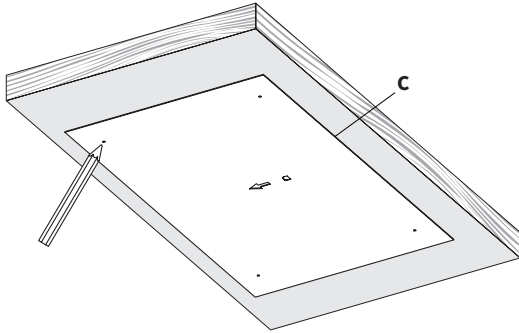

Make sure the arrow on the Template points towards the end that will have your TV.

Pre-Drilling Instructions

Drill mounting holes using infographic below.

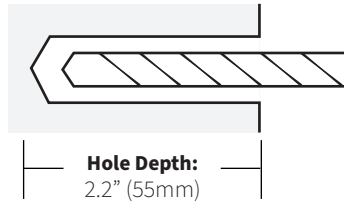

Drill Bit:
3/16" (4.5mm)

Hole Depth:
2.2" (55mm)

Using a socket wrench, insert ST6.3x55mm Screws **(W-A)** into the mounting holes that align with the **Keyhole Slots** of the Mount Extensions **(I)**, leaving a 3mm gap from the ceiling.

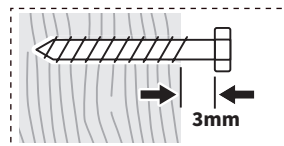
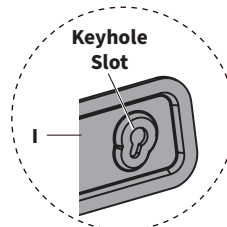
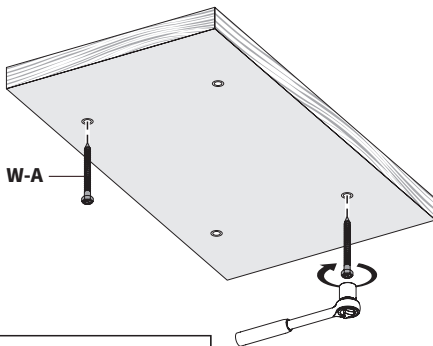

Do NOT use included Anchors (W-B) for wood or drywall.

STEP 4

Raise the Mount Assembly so the ST6.3x55mm Screws (**W-A**) fit through the **Keyhole Slots** of the Mount Extensions (**I**). Turn Mount Assembly until supported by Screws.

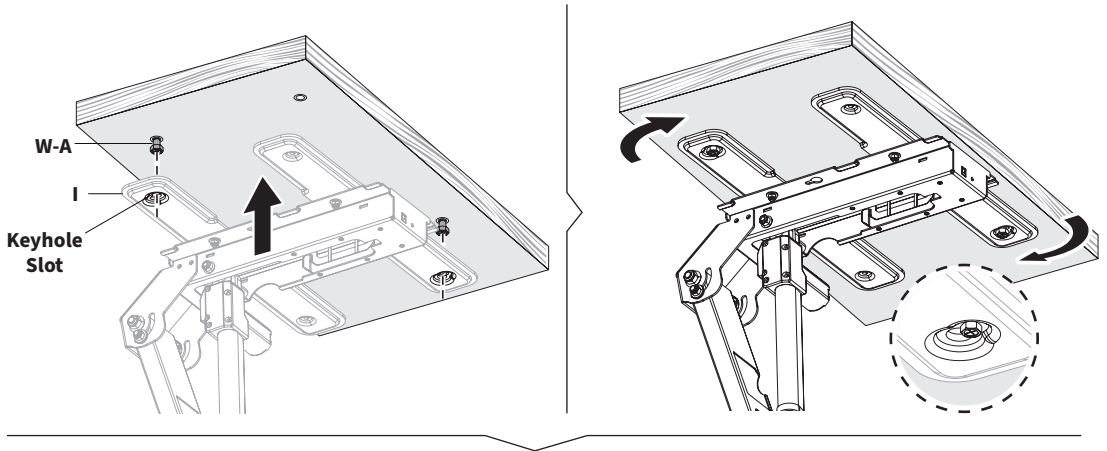

Secure Mount Assembly using the remaining ST6.3x55mm Screws (**W-A**), M6 Washers (**W-C**). Tighten all Screws with a socket wrench.

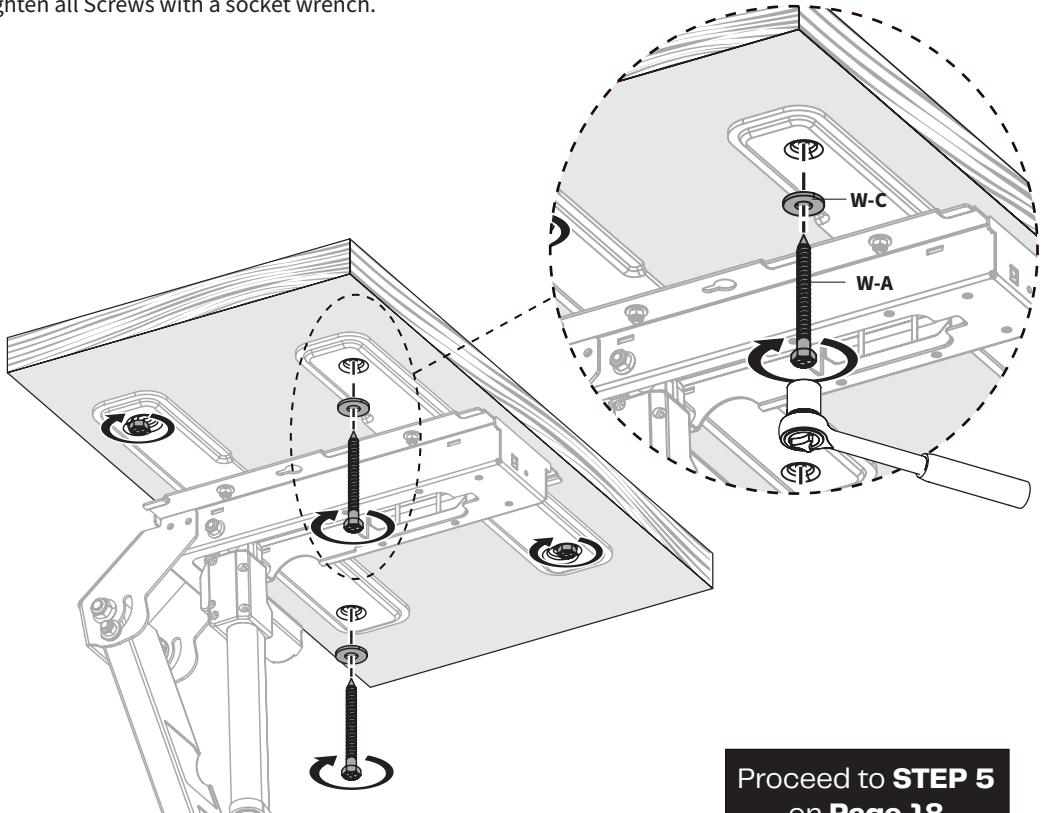

Proceed to **STEP 5**
on **Page 18**

Option 3: Concrete Installation

STEP 3

Position Template **(C)** in desired location and mark mounting holes.

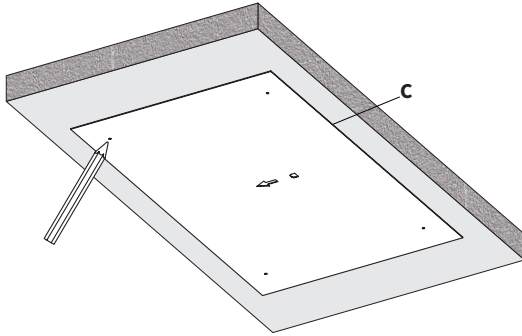

Make sure the arrow on the Template points towards the end that will have your TV.

Pre-Drilling Instructions

Drill mounting holes using infographic below.

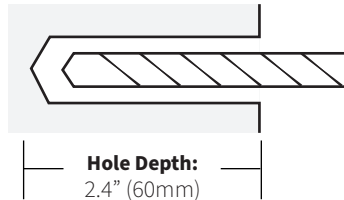

Drill Bit:
3/8" (10mm)

Press Concrete Anchors **(W-B)** into mounting holes. Using a socket wrench, insert ST6.3x55mm Screws **(W-A)** into the mounting holes that align with the **Keyhole Slots** of the Mount Extensions **(I)**, leaving a 3mm gap from the ceiling.

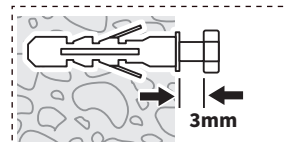
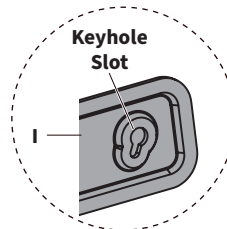
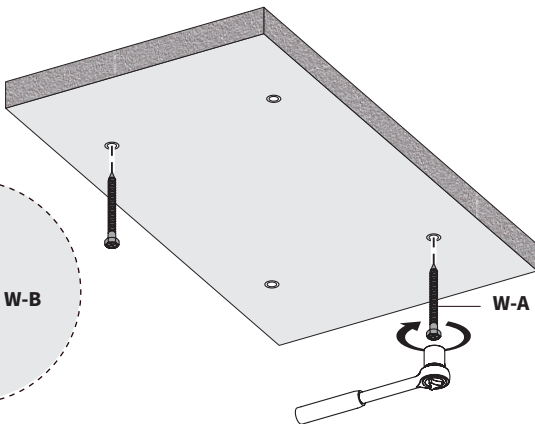
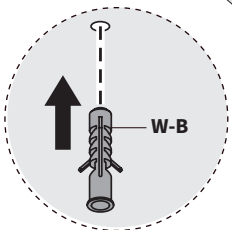

STEP 4

Raise the Mount Assembly so the ST6.3x55mm Screws (**W-A**) fit through the **Keyhole Slots** of the Mount Extensions (**I**). Turn Mount Assembly until supported by Screws.

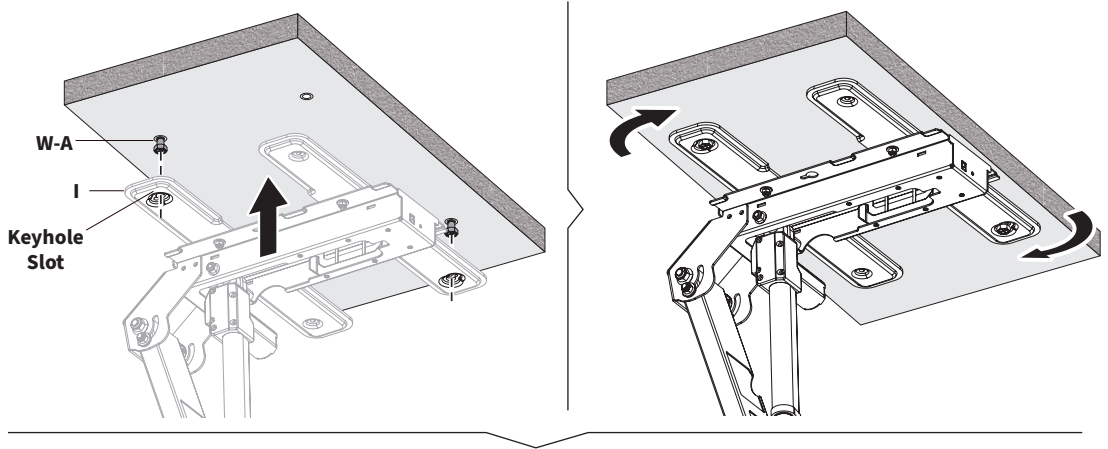

Secure Mount Assembly using the remaining ST6.3x55mm Screws (**W-A**), M6 Washers (**W-C**). Tighten all Screws with a socket wrench.

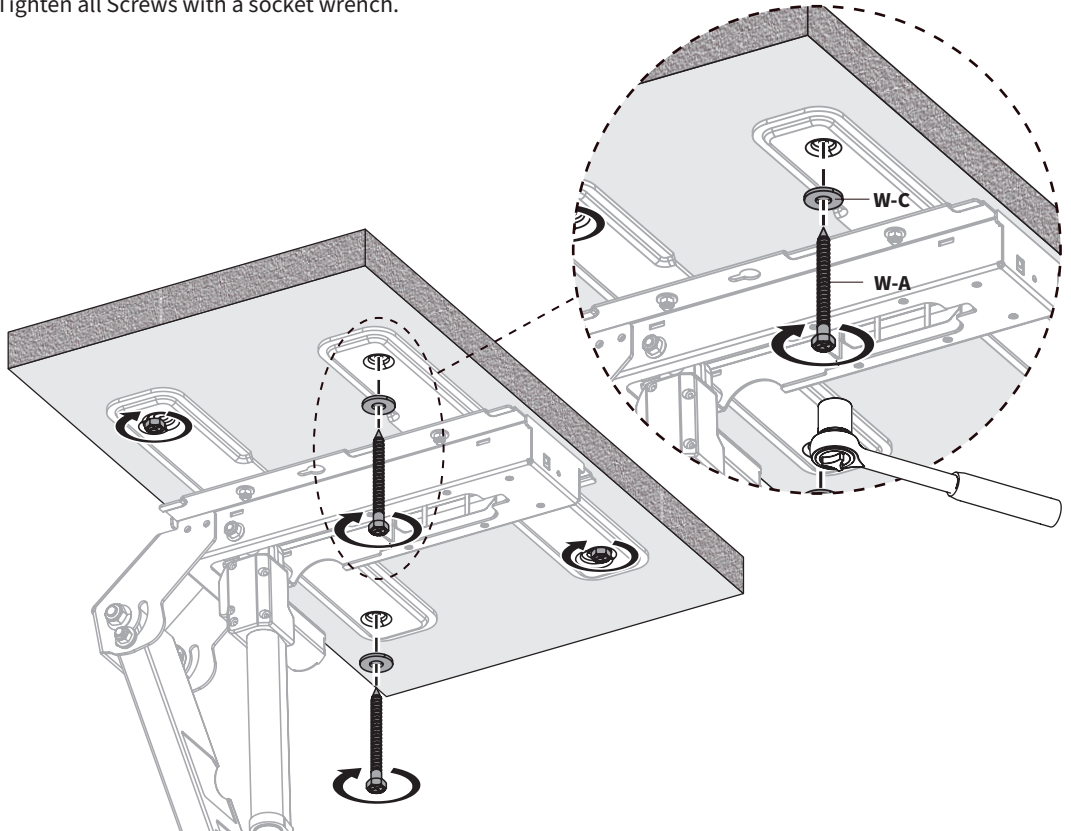

STEP 5

Attach Bracket Rails (**E**) to Center Plate (**B**) using M6x25mm Screws (**S-D**), D6 Washers (**S-E**), M6 Nuts (**S-F**) and a wrench.

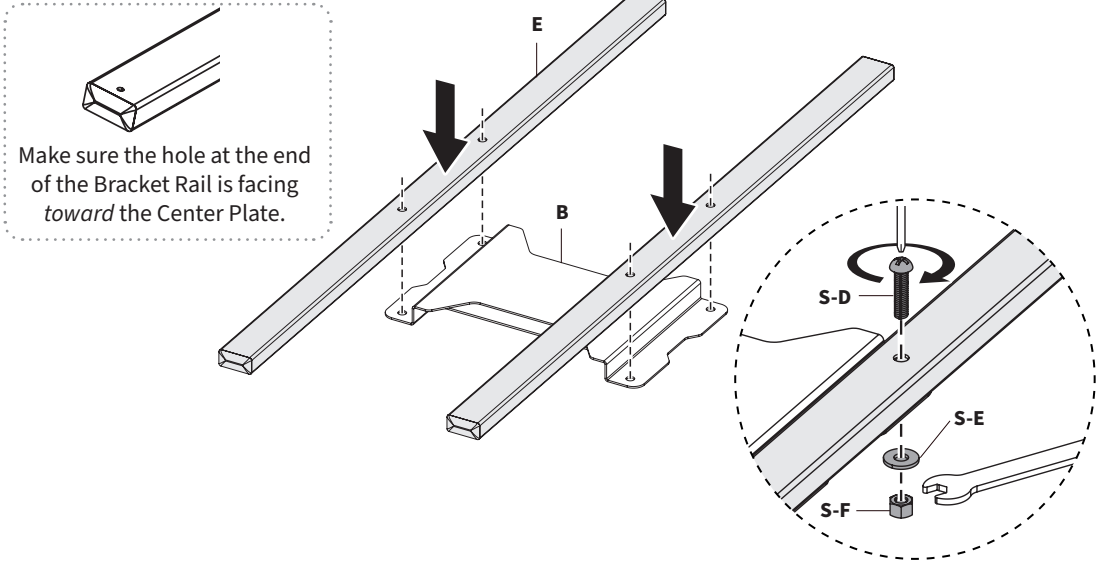

Loosen the top two preinstalled Screws (**B1**) of the Center Plate (**B**) using a Phillips screwdriver, leaving a gap between the head of the Screw and the Center Plate. Remove the bottom two preinstalled Screws (**B2**) at the other end of the Center Plate.

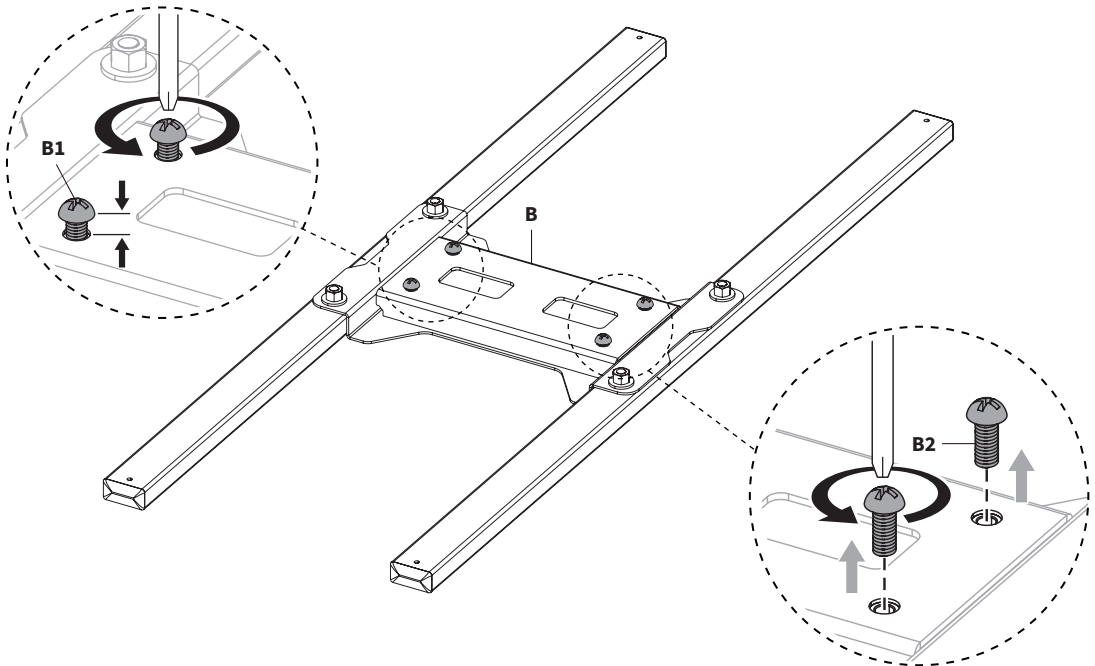

STEP 6

Slide VESA Brackets (**D**) onto Bracket Rails (**E**).

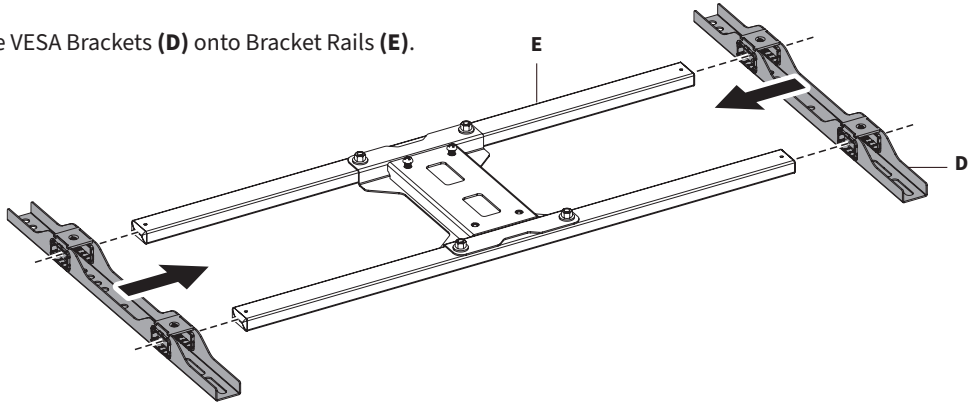

Attach M4x8mm Screws (**S-B**) to Bracket Rails (**E**) using 3mm Allen Wrench (**T-A**).

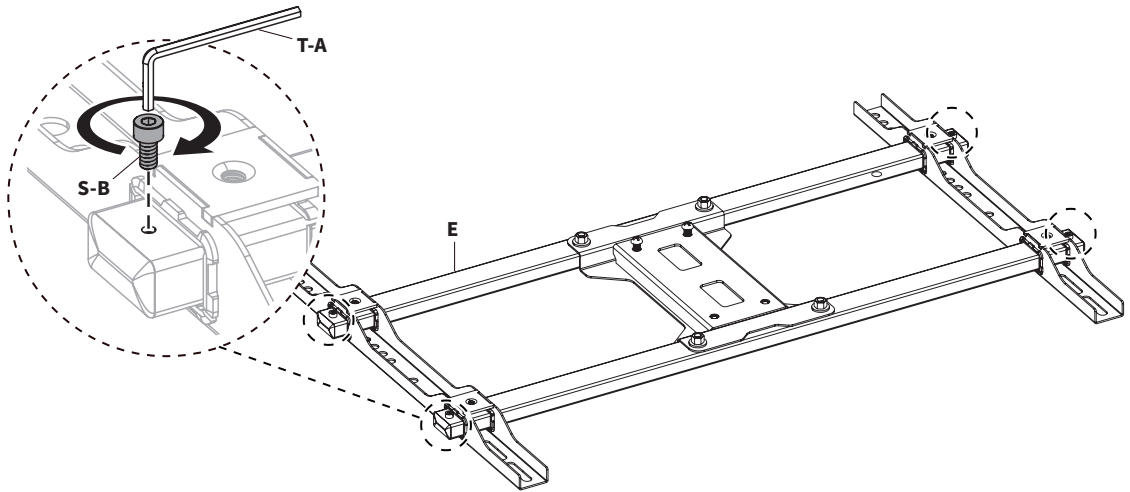

STEP 7

Slide VESA Brackets (**D**) to align to the holes on the back of your TV. Make sure the Center Plate (**B**) is centered between the Brackets.

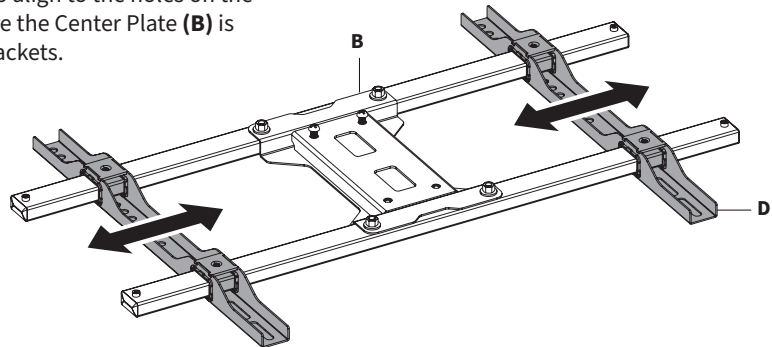

STEP 7 - Cont'd

Attach VESA Assembly to TV using appropriate Mounting Screws (**M-A through M-D**), D8 Washers (**M-E**), and Spacers (**M-F, M-G**).

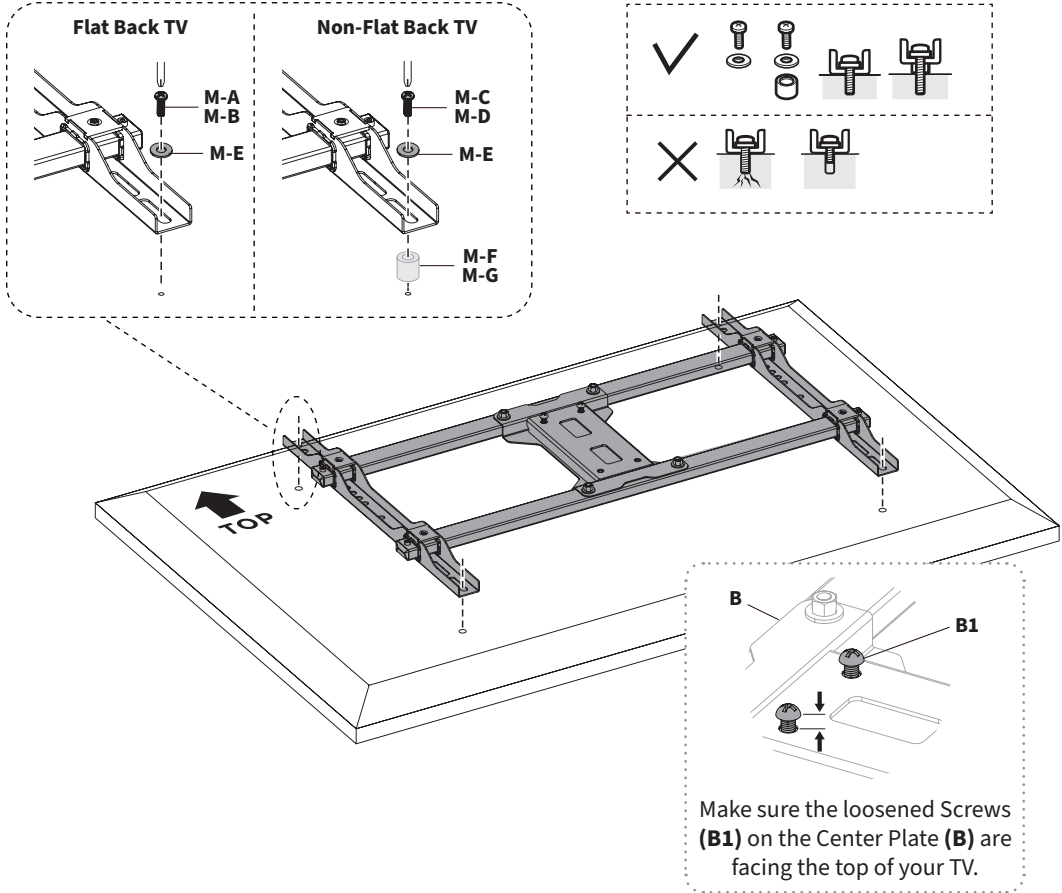

Insert Set Screws (**S-A**) in VESA Brackets (**D**) with 3mm Allen Wrench (**T-A**) to lock them in place.

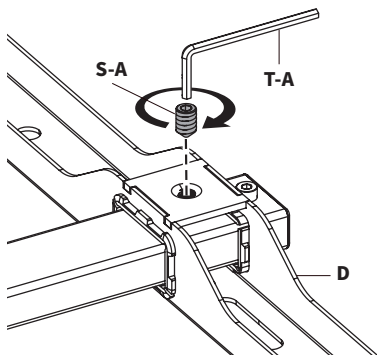

STEP 8

Place the TV Assembly on the Mount **(A)** by lining up the loosened top Screws and inserting into **Mounting Slots** at desired height.

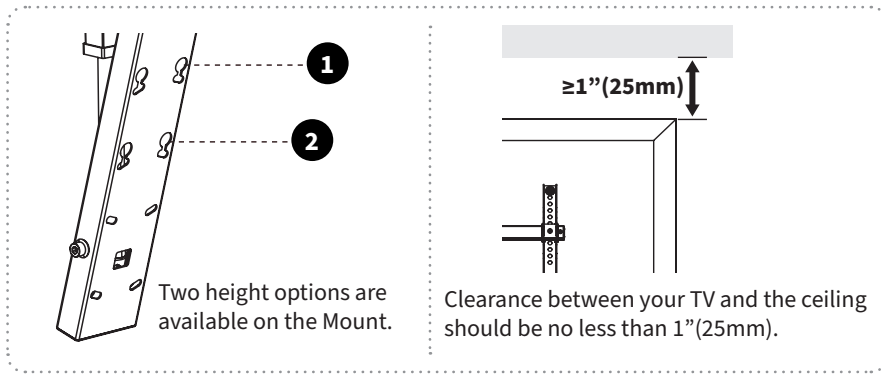
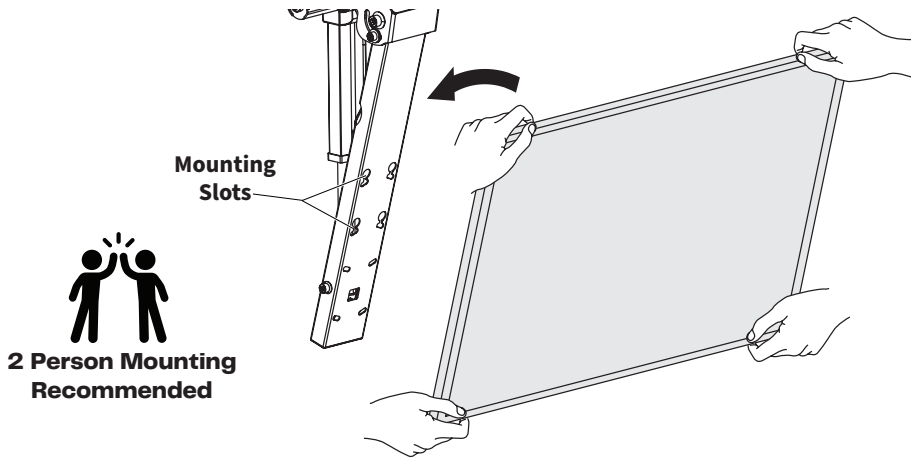

Tighten the loosened top Screws **(B1)** and reinsert previously removed bottom Screws **(B2)**.

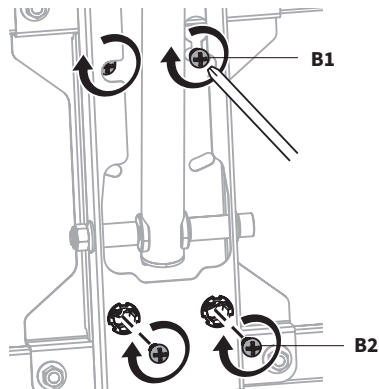

STEP 9

Remove adhesive backing from Cable Clips (**L**) and place them on the Mount (**A**) where desired. Run the TV cable along the Mount.

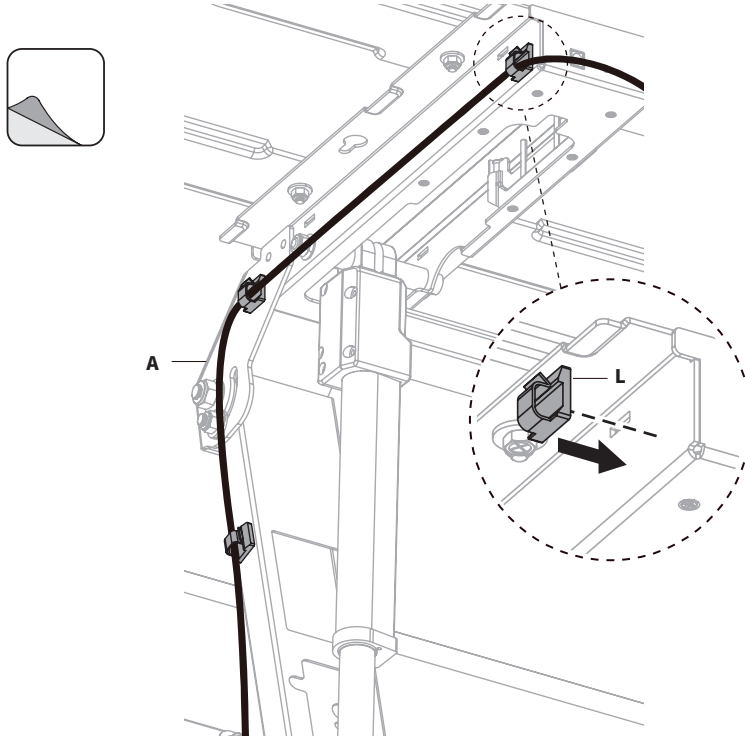

STEP 10

Plug Mount (**A**) into power source with Power Adapter (**H**).

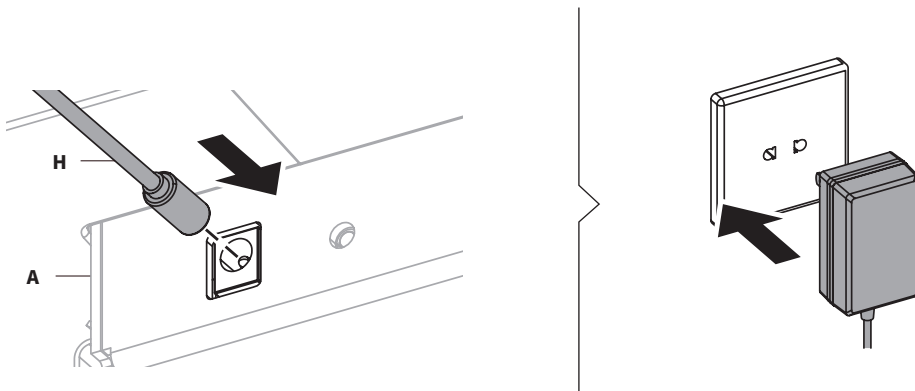

STEP 10 - Cont'd

Attach Left and Right Covers (**F,G**) to the base of Mount (**A**) as shown .

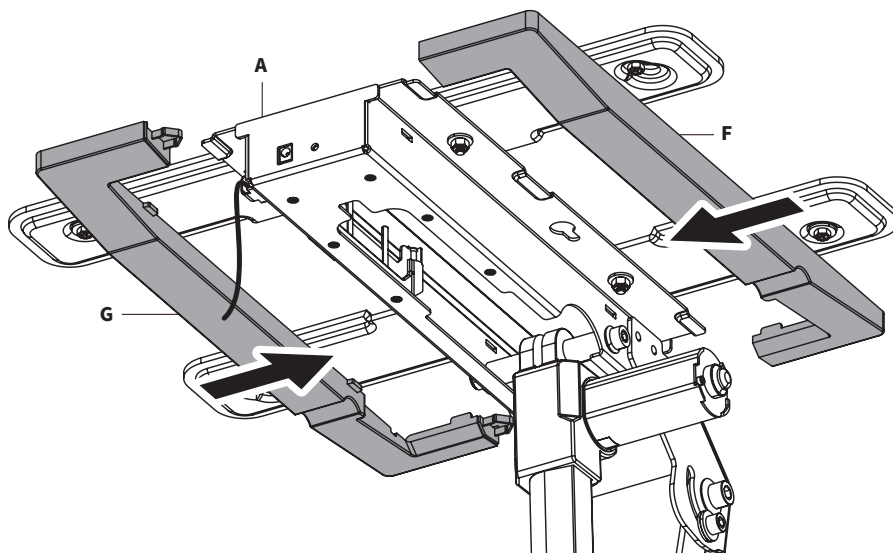

STEP 11

Adjust your TV as desired.

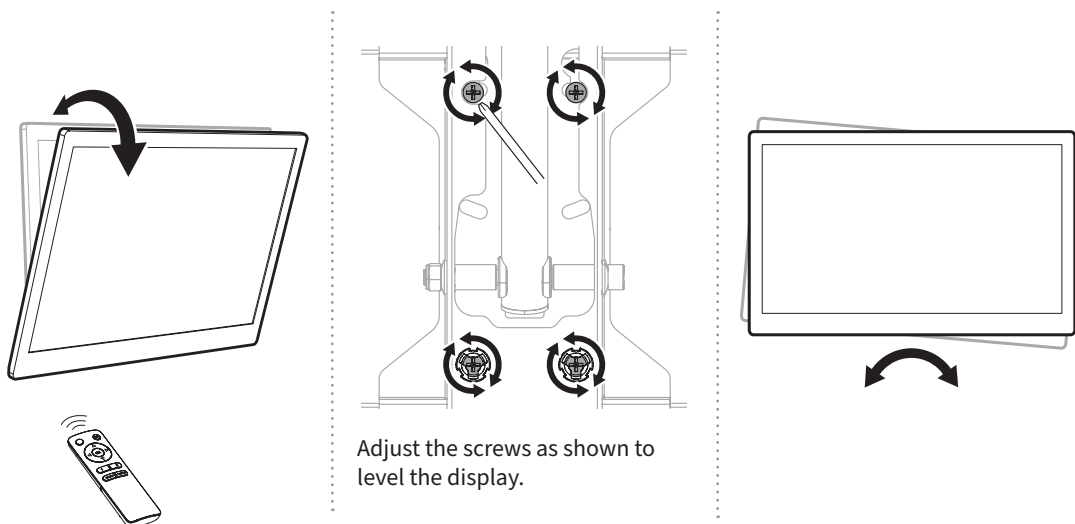

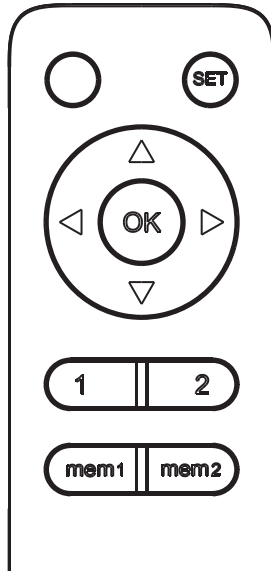



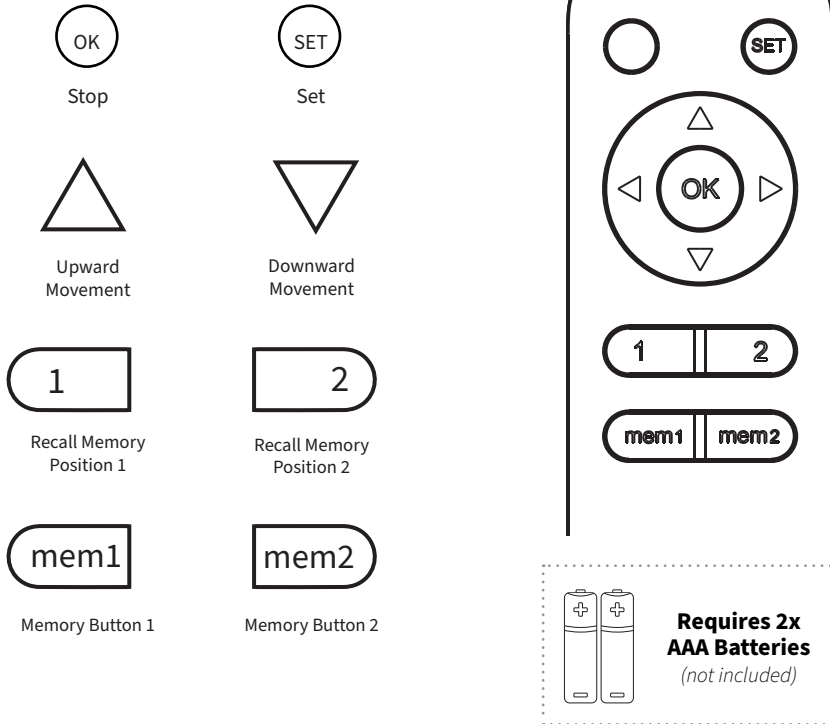

Remote

Overview & Troubleshooting

Remote Control Manual



First Time Use

1. Install two AAA batteries (*not included*) in the Remote.
2. Plug the mount in. The mount will beep once, and will be ready for operation.
3. Press the  button to move the TV upward toward the ceiling. Press the  button to stop the motion.
4. Press the  button to move the TV downwards toward the lowest position (80° angle). Press the  button to stop the motion.



*If the Mount does not respond, Remote may need to be paired. Go to **Page 26** for pairing instructions.*

Save & Recall Memory Settings

To save a certain location to memory, press and hold the **mem1** or **mem2** buttons for 1 seconds. The mount will beep, indicating the position has been saved to memory.

To recall memory locations, press **1** or **2** and the TV mount will automatically adjust to saved memory location of the corresponding memory button.

.....

Reset

Unplug the power for 10 seconds, then re-plug the power. Press the **OK** button for 6 seconds. The Mount will retract to the highest position and then extend to the lowest position. A long beep then indicates that the system has been successfully reset.

.....

Pairing the Remote

Step 1: With the Mount powered on, quick press the small button on the control box with a thin tool as shown. The unit will beep, indicating readiness for pairing.

Step 2: Quick press the **SET** button on the Remote, and the control box will repeatedly beep for approximately 10 seconds indicating that the Remote is being paired. The process will be finished when the beeping ends.

Note: The **SET** button must be pressed within 10 seconds of the Mount's beep.

Note: The Mount can be matched with up to 20 Remotes.

To Unpair Remote: Press and hold the small button on the control box with a thin tool until a long beep is heard.

.....

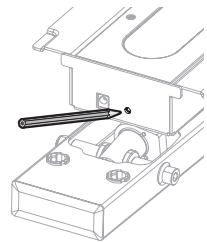

Change the Tilt Range for Angled Ceilings

The Mount's tilt positions range from 0° to 80° by default. You can change the tilt range if you have an angled ceiling by following the steps below.

Step 1: Reset the system following the instructions from the “Reset” section on this page.

Step 2: Press the **▲**, **▼** and **OK** buttons to put your Mount in the proper position.

Step 3: Quick press the **mem1** button 5 times. The unit will emit 2 beeps to indicate success.

Note: Steps 2 and 3 should be finished within 2 minutes, or it will fail to change the tilt range.

Note: To go back to the original tilt range, do a Reset by following the “Reset” instructions above.

Troubleshooting

Find solutions to possible issues in the chart below.

Problem	Solution
The Mount is Making a Buzzing Alarm Sound	This signals an error in Mount position. Reset the system by following the “Reset” instructions on page 26.
Remote Battery Drains Too Quickly	Make sure that your Remote had fresh batteries. If problem persists with fresh batteries, please contact us at 309-278-5303 or help@vivo-us.com to replace the Remote.
Remote Buttons Don't Work	Check to make sure the Remote has working batteries. If the problem persists, try to re-pair the Remote following the “Pairing the Remote” instructions on page 26. If the problem persists, please contact us at 309-278-5303 or help@vivo-us.com to replace the Remote. If the problem persists with the replacement Remote, contact us to replace the product.
Remote Has Limited Range	If your Remote has a limited range and won't function unless it is within 10 feet (3 meters) of the Mount, replace the batteries. If the problem persists, please contact us at 309-278-5303 or help@vivo-us.com to replace the Remote.
Mount Has Limited Tilt Range	If your TV can't reach the angles of 0° or 80°, reset the system following the instructions of the “Reset” section on <i>page 26</i> . If the problem persists, please contact us at 309-278-5303 or help@vivo-us.com to replace the Remote. help@vivo-us.com to replace the product.
Mount Won't Operate	Check to see if the Power Adapter is properly connected to the Mount. If so, plug the Power Adapter into a power source. If there is no buzzer tone or red light power indication, please contact us at 309-278-5303 or help@vivo-us.com to replace the Power Adapter. If the problem persists with the replacement Power Adapter, contact us to replace the product.
Mount Makes an Abnormal Noise	Please contact us at 309-278-5303 or help@vivo-us.com to replace the product.

[THIS PAGE HAS BEEN INTENTIONALLY LEFT BLANK]

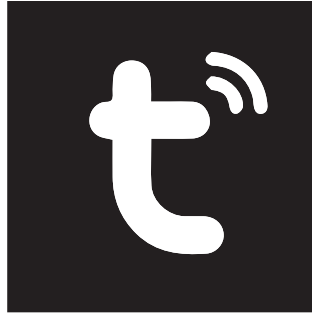

TUYA[®] Smart | Mobile App

Setup & Use

DOWNLOAD **TUYA SMART** APP IN YOUR APP STORE



GET IT ON
Google Play



Download on the
App Store



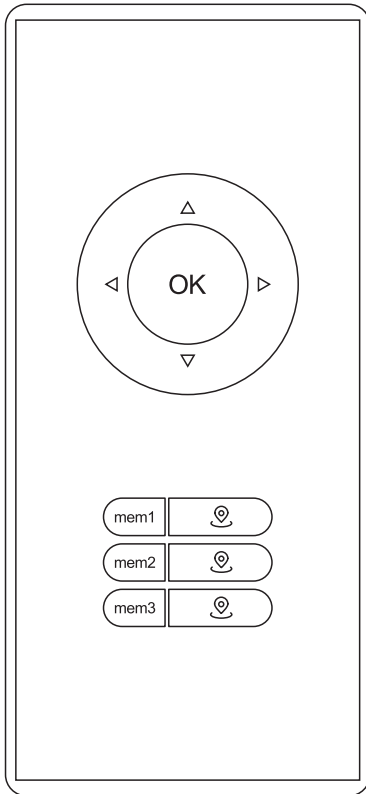

Tuya App | Basic Functions







UPWARD
MOVEMENT

STOP

DOWNWARD
MOVEMENT



 
MEMORY SET 1 MEMORY RECALL 1



 
MEMORY SET 2 MEMORY RECALL 2

 
MEMORY SET 3 MEMORY RECALL 3



Standard Operation

Using Arrow Keys

UP: Tap the  button to move the TV upward toward the ceiling. Press the  button to stop the motion.

DOWN: Tap the  button to move the TV downwards toward the lowest position. Press the  button to stop the motion.

Saving & Using Memory Settings

Use the arrow buttons to set your desired TV position. Then select one of the 3 Memory Buttons to save the position as a preset. To return to a preset, simply select the  icon next to the desired Memory setting. For example, to return to Memory Setting 2, select the  icon next to .

Please note: Tuya Smart app has three memory functions, while the standard remote has only two.

Setting Up & Creating an Account

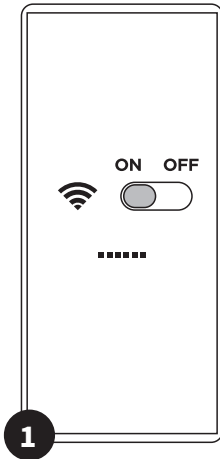

TURN ON WIFI

Before you begin, ensure that Wifi is switched on your phone.



CREATE ACCOUNT

Open Tuya Smart App and select **Sign-Up** from start screen. Follow on screen prompts.

If Mount will not appear, quick press the **mem2** button 5 times to disconnect from the app.

Pairing to Mount

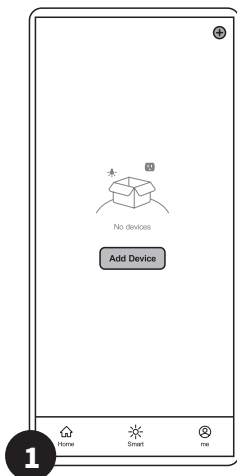

ADD DEVICE

Tap **Add Device** or the + icon in upper right corner to begin device pairing.

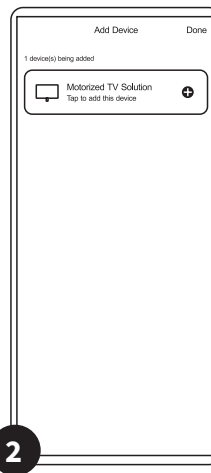

MOTORIZED TV SOLUTION

Tap *Motorized TV Solution* in the Auto Scan page and go to "Next".

Only one Tuya Smart account can be synced to Mount at one time.

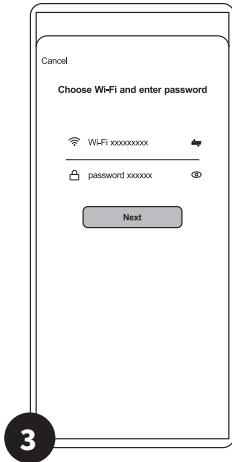

CONNECT TO WIFI

Select your Wifi from available list and enter password to enable mount access. Tap “Next”.

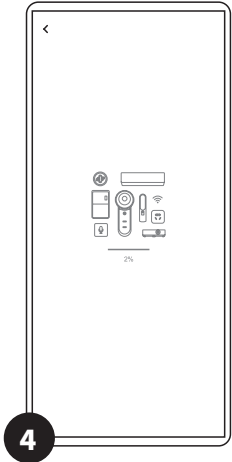

CONNECTION SCREEN

If Wifi connection was successful, connection to your TV mount will begin. Please allow 10-60 seconds for connection process to be completed.

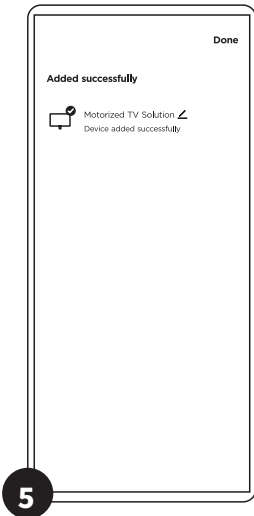

DEVICE ADDED SUCCESSFULLY

Once connection is made, a confirmation screen will show. Click “Done” to enter the Remote Dashboard.

Note: From here, you can tap the ↙ icon to change the name of your TV mount, if desired.

Unpairing Mount from App

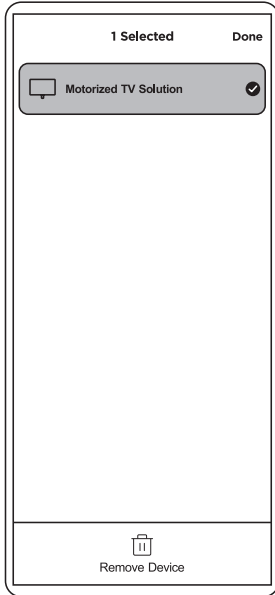

From the Home screen, locate your TV mount, then long press to open device options.

Select **Remove Device** at the bottom of the screen to unpair the mount from your app. OR quick press the **mem2** button 5 time. Two beeps are emitted signaling the mount is disconnected from the app.

Syncing Other Mobile Devices

To allow other mobile devices to control the TV mount, you will need to first create **Home** in the app and then invite other users to your Home.

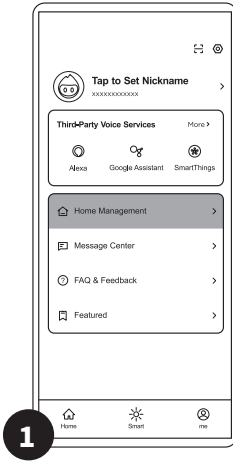

HOME MANGEMENT

Select the **ME** (👤) icon to navigate to the Home screen. Tap **Home Management**.

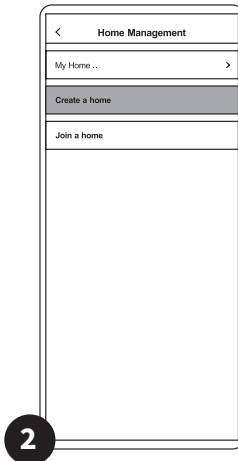

CREATE A HOME

Tap **Create A Home** to proceed.

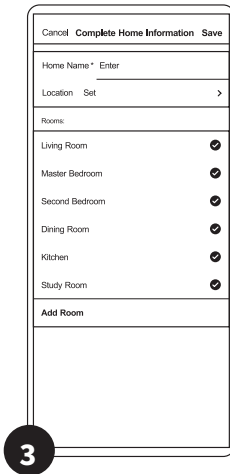

SET UP HOME

Complete required information to set up a HOME and tap **SAVE** to continue.

Please note: The **Home Name** has a 25 character limit.

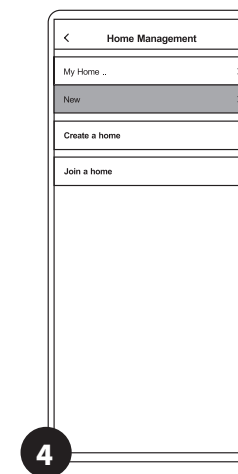

HOME

Return to Home Management screen and tap the **Home** you just created.

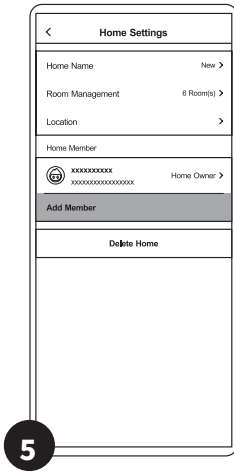

INVITE OTHER MEMBERS

Tap **Add Member** and choose an invitation method. New users will receive link to download Tuya Smart app with an invitation code to join your **Home**. Users will need to download app and create an account to proceed.

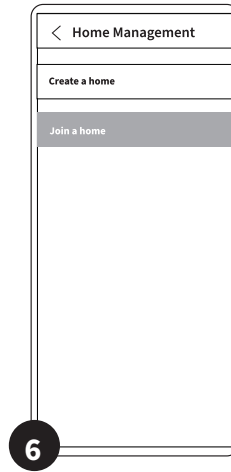

JOINING A HOME

Once app is installed and registered, new user will tap the **ME** (👤) icon on the bottom right. From that screen, tap **Home Management** and then **Join a Home**.

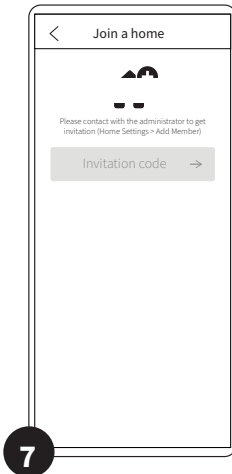

ENTER INVITATION CODE

Enter the code that was received with the invitation and tap ➔ to continue.

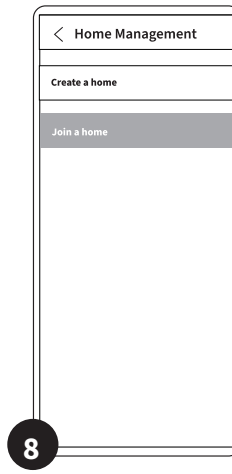

HOME ADDED

The new **Home** will now show under **Home Management**.

Setting Up Amazon Alexa

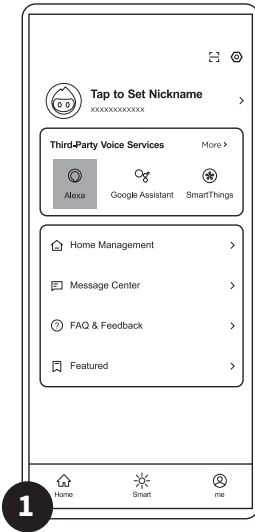

DOWNLOAD AMAZON ALEXA APP

First, download the Amazon Alexa app from the app store or Google Play. Once installed, return to the Tuya app and click on "me" in the bottom right corner, and click the "Alexa".

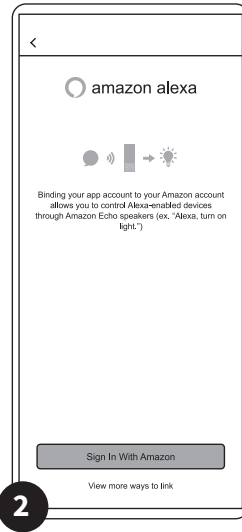

SIGN IN

Click "Sign in with Amazon".

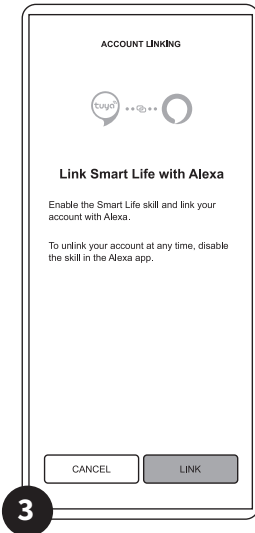

LINK

Click "Link" to begin the linking process.

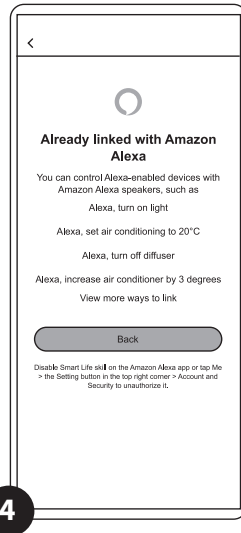

DEVICE ADDED

Once the linking is complete, you can start controlling the TV mount via Amazon Alexa.

Setting Up Google Home

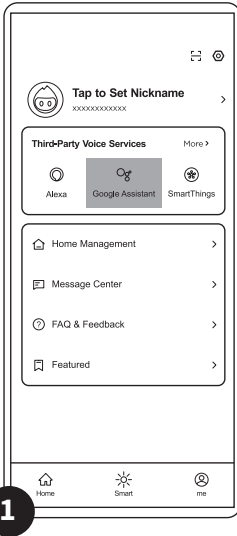

DOWNLOAD GOOGLE HOME APP

First, download the Google Home app from the app store or Google Play. Once installed, return to the Tuya app and click on "me" in the bottom right corner, and click the "Google Assistant".

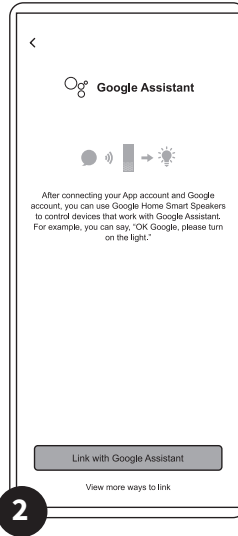

LINK

Click "Link with Google Assistant" to launch the Google Home app.

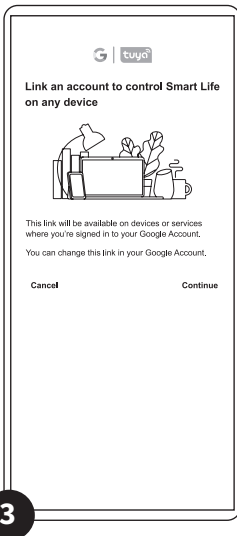

CONTINUE

Click "Continue" to return to the Tuya App.

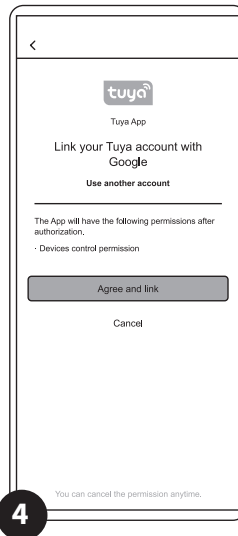

DEVICE ADDED

Click "Agree and link" to return to the Google Home app. The linking is complete, and you can start controlling the TV mount via Google Home.

Voice Controls

Commands	Amazon Alexa	Google Home
Upward Movement	Alexa, set <devicename> to up	OK Google, set , <deviceName> to up
Downward Movement	Alexa, set <devicename> to down	OK Google, set <deviceName> to down
Stop	Alexa, set <devicename> to stop	OK Google, set <deviceName> to stop
Save Current Position as Memory 1	Alexa, set <devicename> to Memory one	OK Google, set <deviceName> to Memory one
Save Current Position as Memory 2	Alexa, set <devicename> to Memory two	OK Google, set <deviceName> to Memory two
Save Current Position as Memory 3	Alexa, set <devicename> to Memory three	OK Google, set <deviceName> to Memory three
Move to Saved Memory Position 1	Alexa, set <devicename> to Position one	OK Google, set <deviceName> to Position one
Move to Saved Memory Position 2	Alexa, set <devicename> to Position two	OK Google, set <deviceName> to Position two
Move to Saved Memory Position 3	Alexa, set <devicename> to Position three	OK Google, set <deviceName> to Position three
Move to Initial Position	Alexa, set <devicename> to Home	OK Google, set <deviceName> to Home



Better Products for a Better Workspace Experience

We are dedicated to creating high-end ergonomic solutions
for the office with top of the industry support.

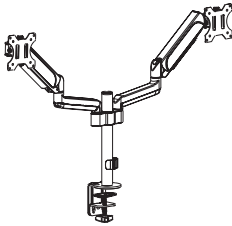

Monitor Mounts

Mount ultrawide monitors
and more with our clamp-on
and wall mount solutions.

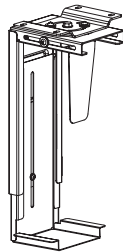

PC Carts & Mounts

Securely store your PC in
an under desk mount or
cart for easy access.

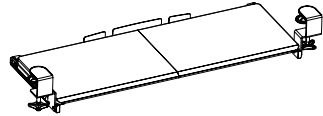

Keyboard Trays

Clamp on & under desk
keyboard tray options for
all setup types.

Explore Endless Workspace Solutions
www.vivo-us.com



Need Help? **We're Here For You**

Monday-Friday from 7am-7pm CST

Saturday 8am-4pm CST



Email Us
help@vivo-us.com



Chat with Live Agent
www.vivo-us.com



Give Us a Call
309-278-5303 ext. 1



VIVO-us



@vivo_us



@VIVOus



VIVO