

ASSEMBLY INSTRUCTIONS

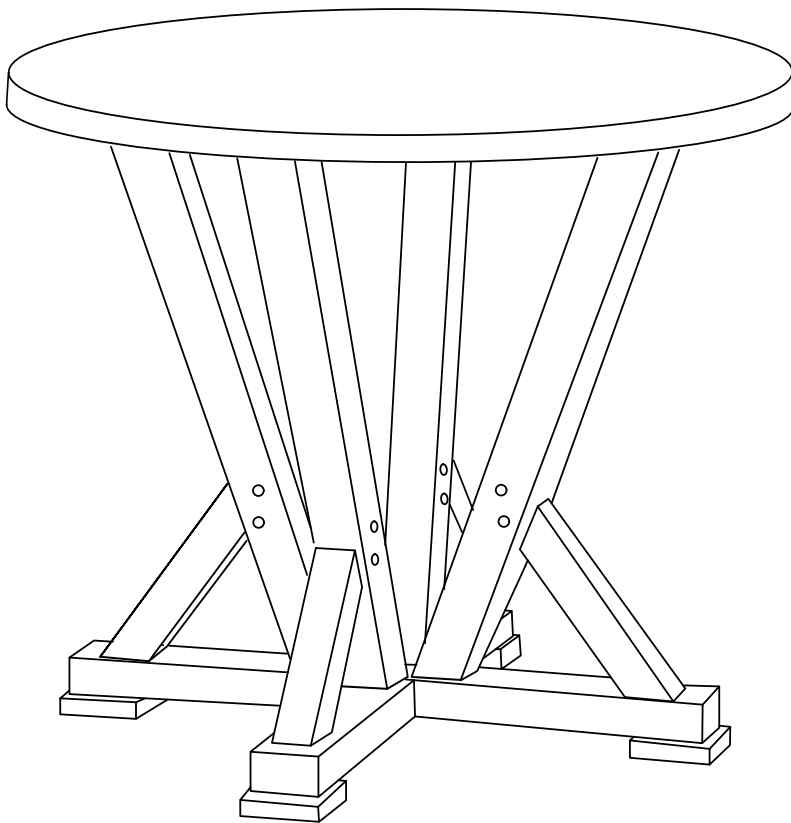

TOOLS REQUIRED



Allen Wrench

(Included)



**2 - People
Recommended**

ASSEMBLY RATING



EASY —————> DIFFICULT

The Assembly Rating is a 5-point system showing the level of effort needed to assemble a specific product.

Thank you for your purchase!

We hope you enjoy this new addition to your home for many years to come.



CHECK BEFORE STARTING

Are you missing anything?

Double-check all parts, hardware and accessories listed are all accounted for.

Check out our Quick Tips!

We recommend reviewing the pre-assembly handouts. Even experts need a refresher now and then!

Should we send any replacements?

Are there any irregularities or flaws in the parts? We can send replacements!

Prep Time!

Please review the assembly instructions and all diagrams prior to assembling.

PRE ASSEMBLY INTRODUCTION

We understand building ready-to-assemble furniture can be a challenging experience for some. To help avoid confusion, we have provided some helpful tips that may speed up the process.



Teamwork

ALWAYS have at least two people to help with transporting and assembling the product to avoid potential injury and/or damage.



Suitable Location

Assembling near the area of the intended location is highly recommended.



Sufficient Space

Make sure you have enough space to move around during the assembly.



Avoid Scratches

Use cardboard, blankets or a carpeted area while assembling furniture to prevent to prevent scratches and damages.



Flat Surface

Make sure the furniture rests on a flat and level surface with each leg evenly touching the floor.

ASSEMBLY AND CARE ADVICE



FAILURE TO FOLLOW THE GUIDELINES BELOW MAY RESULT IN INJURY AND/OR PROPERTY DAMAGE.



Position each part correctly and insert screws or bolts into their respective holes.

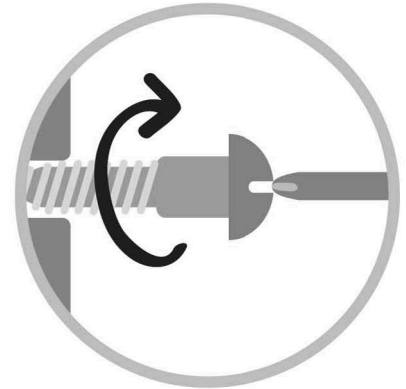

Turn clockwise to tighten and only tighten when step is completed or when instructed to do so.



Save the instructions and store any supplied tools for later maintenance.

Use the appropriate hand tools or power tools for assembly. Select steps, such as tightening screws and/or bolts, may require hand tools to avoid causing damage during assembly.



After two weeks, check and tighten any loose hardware and repeat again every six months thereafter.

IT IS THE USER'S RESPONSIBILITY TO MAINTAIN THE FURNITURE. THE HARDWARE MAY LOOSEN OVER TIME AND MAY CAUSE THE FURNITURE TO BE WOBBLY AND UNABLE TO SUPPORT ITS INTENDED WEIGHT CAPACITY. THIS MAY LEAD TO COLLAPSE AND MAY CAUSE SERIOUS INJURY.

ROUND COUNTER HEIGHT TABLE

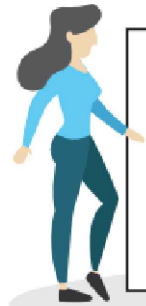

- Please keep instructions for future reference.
- Check the quantity and irregularity of parts and hardware before you start.

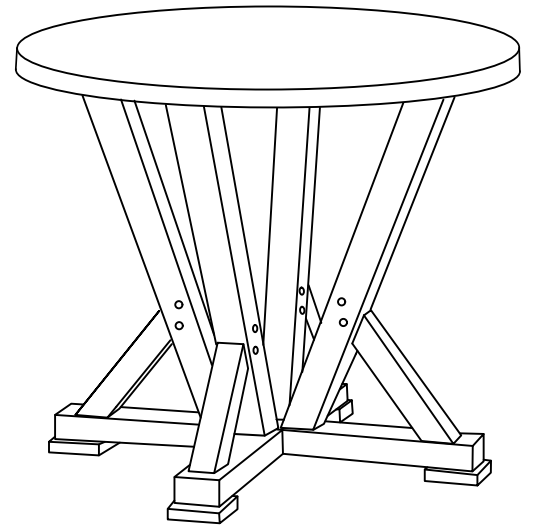

PARTS

#1 1pc



Table Top

#2 1pc



Upper Mounting Plate

#3 1pc

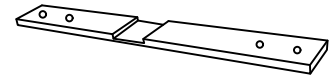

Lower Mounting Plate

#4 4pcs

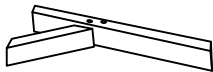

Leg Assembly

#5 1pc



Upper Leg Base

#6 1pc

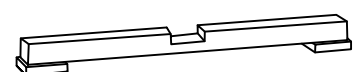

Lower Leg Base

HARDWARE

#A 10pcs



M6 x 35MM
Bolt

#B 8pcs



M6 x 80MM
Bolt

#C 16pcs



M6 x 13MM
Spring Washer

#D 16pcs



M6 x 19MM
Flat Washer

#E 4pcs







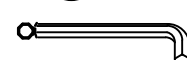



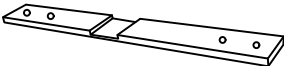
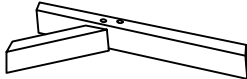

M6 Adjuster
Base Leg

#F 1pc

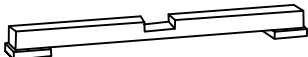

M4 X 110MM
Allen Wrench

CM3289-RPT is packed in 2 cases

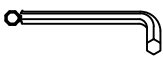
Carton	Designation		Part	Hardware
CM3289 -RPT-1	Table Top	# 1		
	Upper Mounting Plate	# 2		
	Lower Mounting Plate	# 3		
CM3289 -RPT-2	Leg Assembly	# 4		 #A x 10pcs  #B x 8pcs
	Upper Leg Base	# 5		 #C x 16pcs  #D x 16pcs
	Lower Leg Base	# 6		 #E x 4pcs  #F x 1pc

ASSEMBLY INSTRUCTIONS

1

Align the Leg Assembly (#4) to the Upper Leg Base (#5) then secure by using bolts (#B) then with washers (#C,D).

Part #4 x2pcs

Part #5 x1pc

Hardware #B x4pcs

Hardware #C x4pcs

Hardware #D x4pcs

Hardware #F x1pc

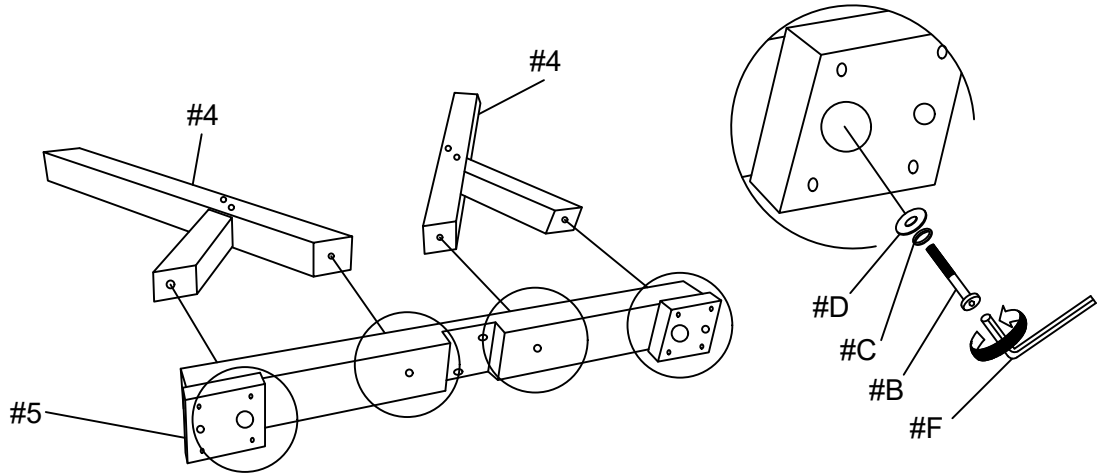

2

Part #1 x1pc

Hardware #F x1pc

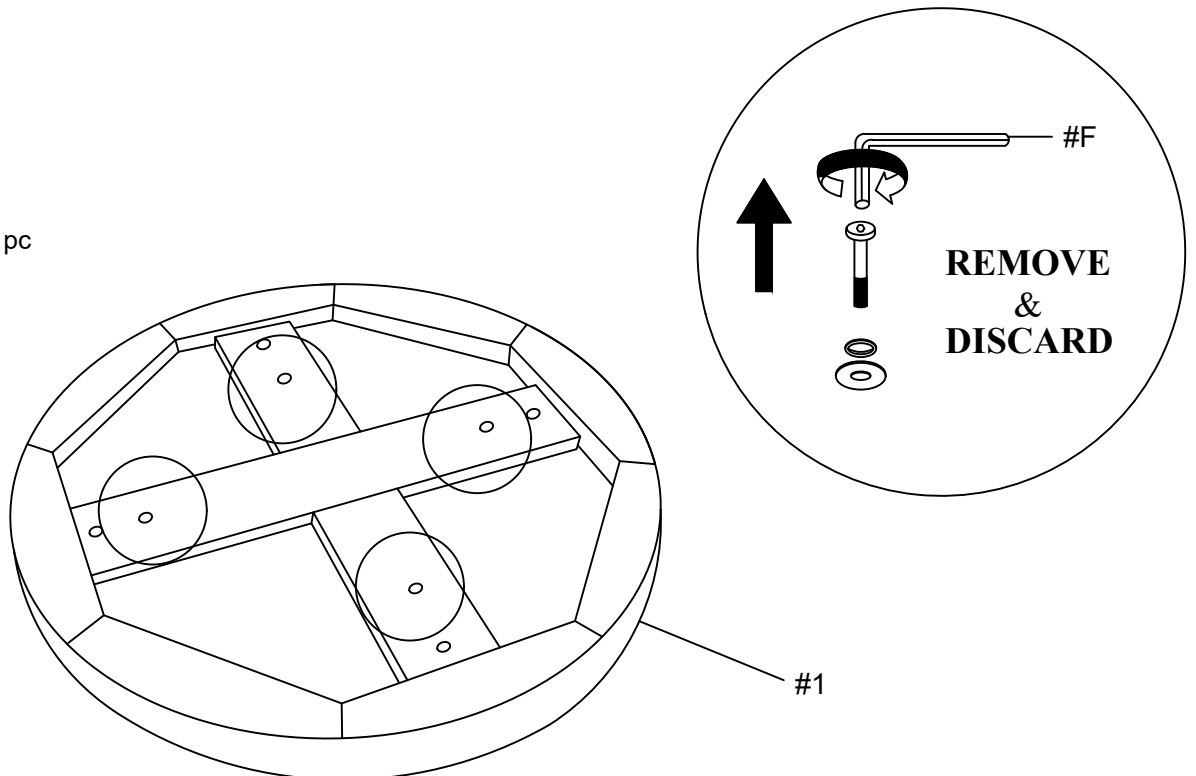

ASSEMBLY INSTRUCTIONS

3

Align the Lower Mounting Plate (#3) to the Leg Assembly (#4) then secure by using bolts (#A) then with washers (#C,D).

Part #3 x1pc

Hardware #A x2pcs

Hardware #C x2pcs

Hardware #D x2pcs

Hardware #F x1pc

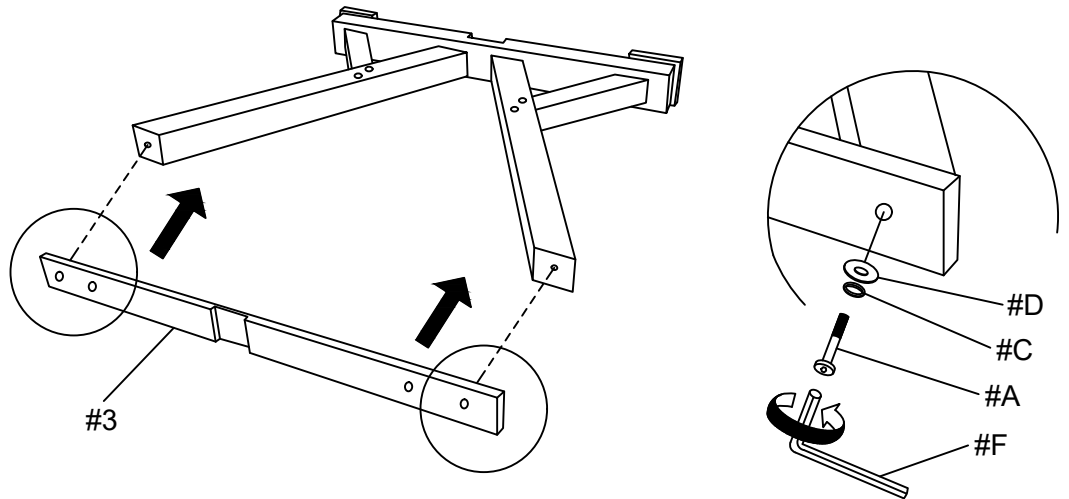

4

Align the Lower Leg Base (#6) to the Upper Leg Base (#5) then secure by using bolts (#A).

Part #6 x1pc

Hardware #A x2pcs

Hardware #F x1pc

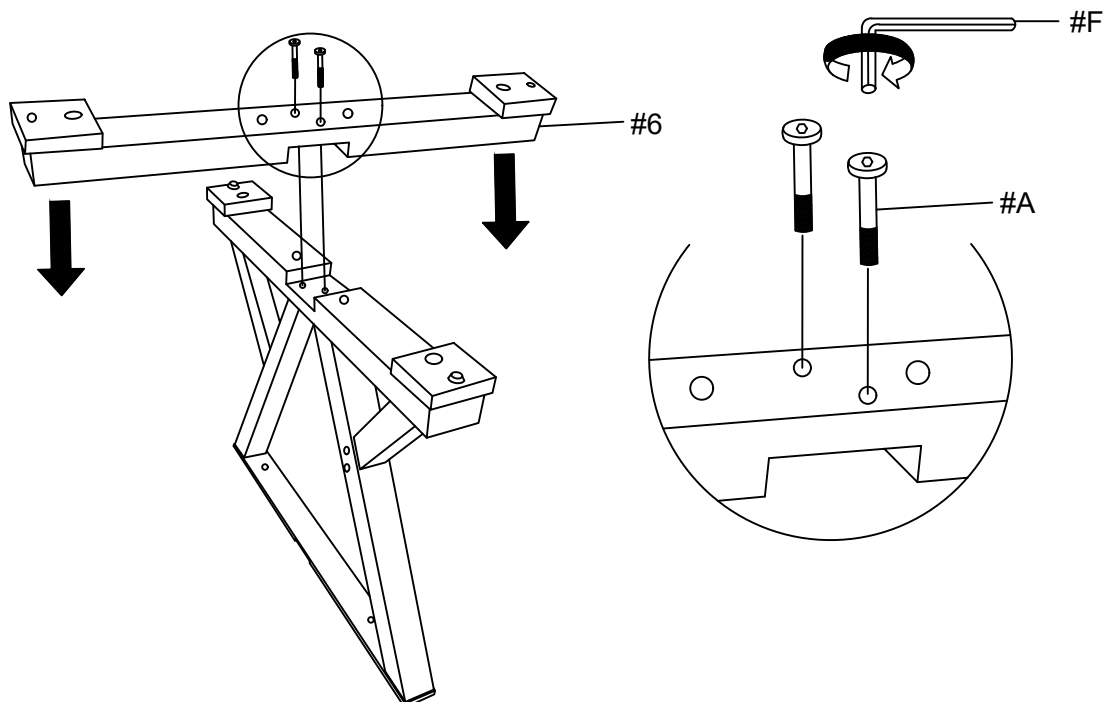

ASSEMBLY INSTRUCTIONS

5

Align the Leg Assembly (#4) to the Lower Leg Base (#6) then secure by using bolts (#B) then with washers (#C,D).

Part #4 x2pcs

Hardware #B x4pcs

Hardware #C x4pcs

Hardware #D x4pcs

Hardware #F x1pc

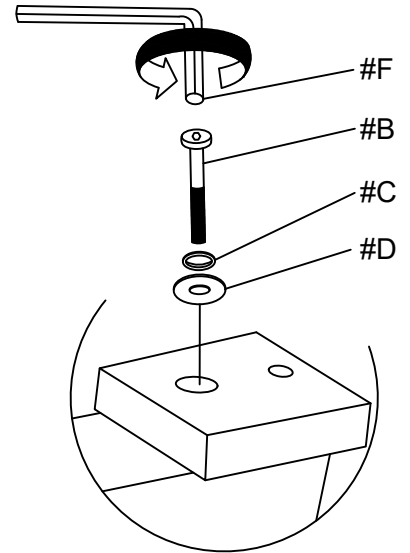
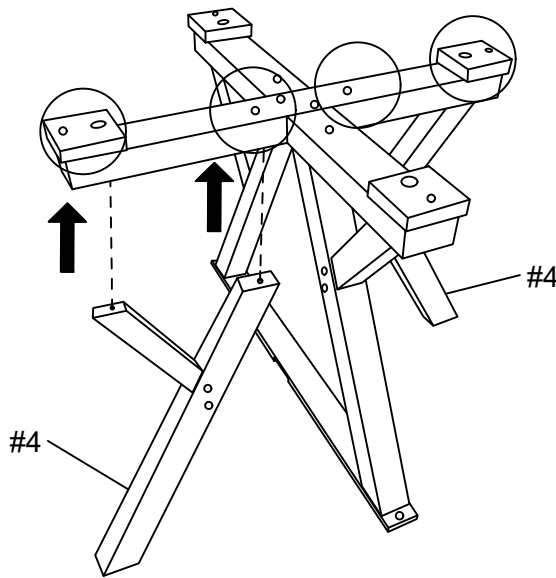

6

Align the Upper Mounting Plate (#2) to the Leg Assembly (#4) then secure by using bolts (#A) then with washers (#C,D).

Part #2 x1pc

Hardware #A x2pcs

Hardware #C x2pcs

Hardware #D x2pcs

Hardware #F x1pc

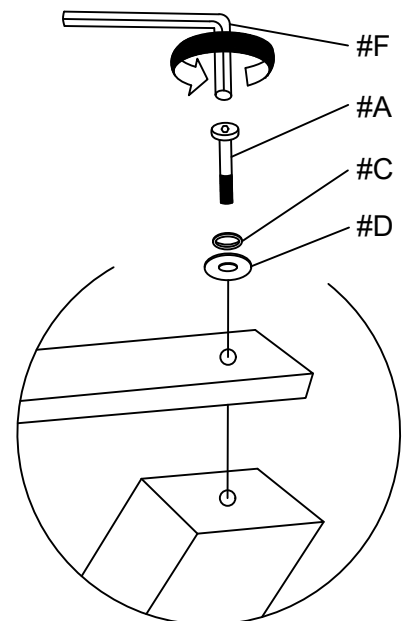
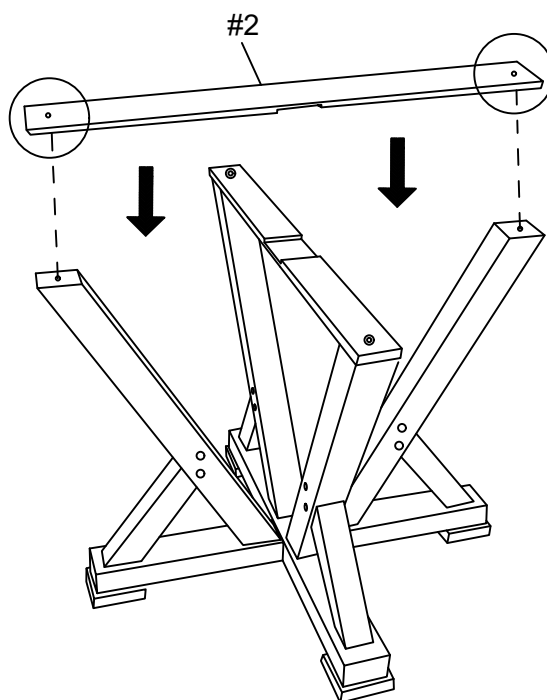

ASSEMBLY INSTRUCTIONS

7

Align the Mounting Plate Assembly to the Table Top (#1) then secure by using bolts (#A) then with washers (#C,D).

Part #1 x1pc

Hardware #A x4pcs

Hardware #C x4pcs

Hardware #D x4pcs

Hardware #F x1pc

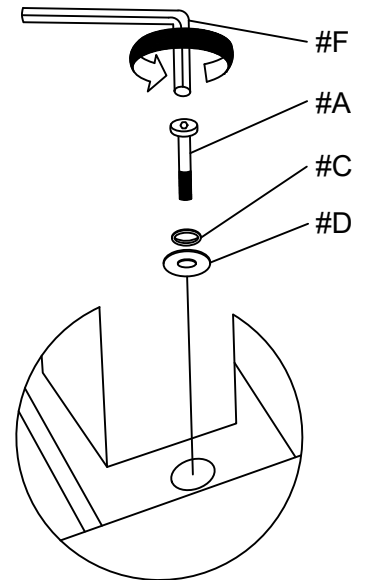
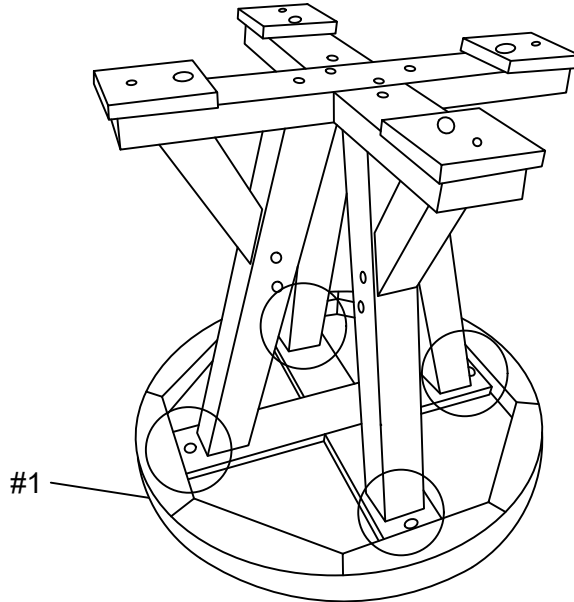

8

Insert Leveler (#E) to Base (#5, 6).

Hardware #E x4pcs

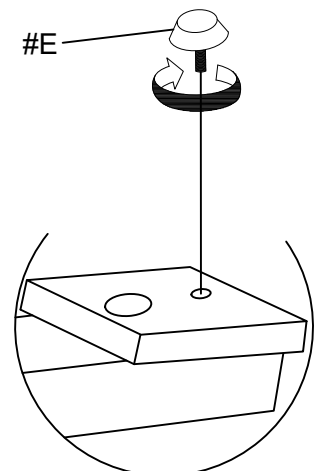
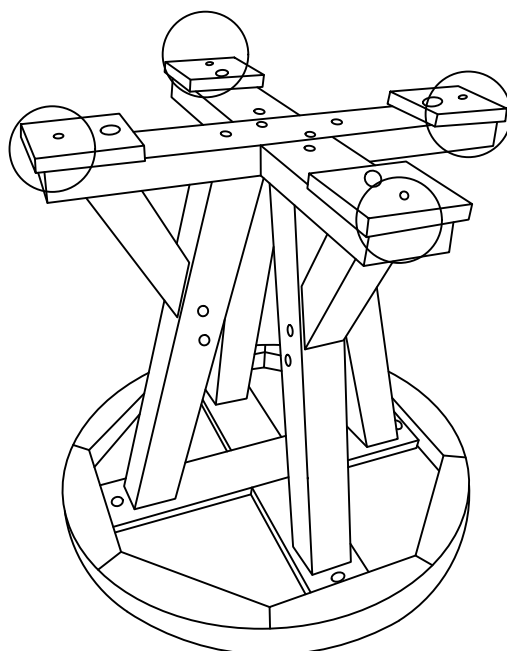

ASSEMBLY INSTRUCTIONS

9

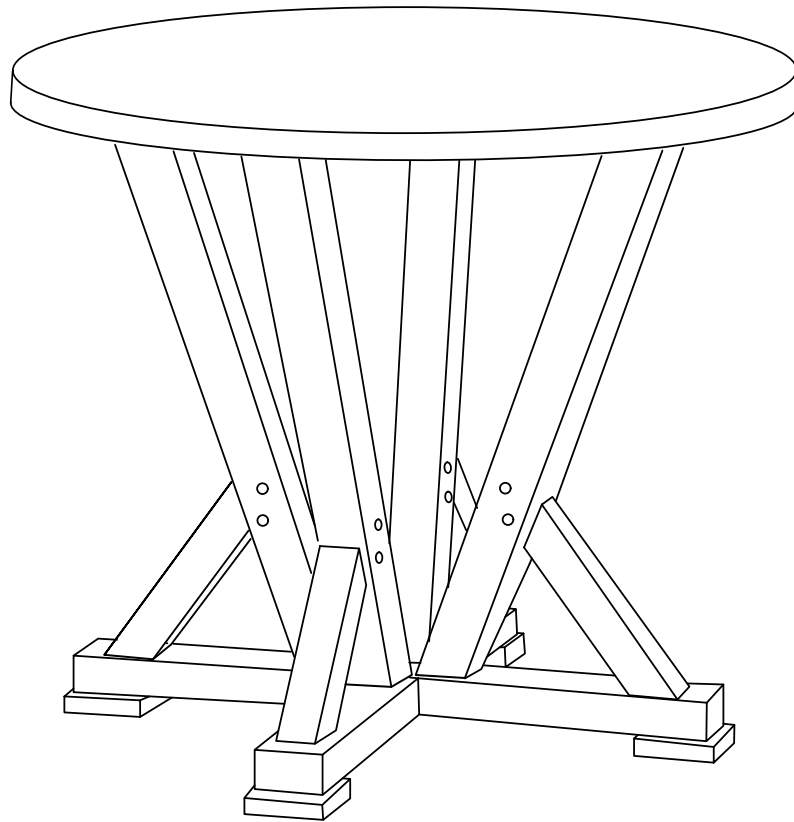

ASSEMBLY COMPLETED



Please ensure the furniture rests on an even and flat surface. If the product wobbles or feels loose, double-check all bolts and/or screws are properly tightened and secured.



Keep this handy!

Please retain this instruction manual and any order-related information for future reference.



Lift, don't drag!

To avoid damage to product please always LIFT the product when transporting or adjusting the placement.