

Read this instruction carefully. See hardware and furniture part list for guidance. Be sure all parts are complete, before you assemble. Place all wooden furniture parts on a clean and flat soft surface to prevent from being scratched. Follow the figure to start assembling.

**CAUTIONS :**

1. Do not FULLY - TIGHTEN the nut or nut bolt until all nut or bolt is ready assembled.
2. Do not OVER - TIGHTEN the nut or bolt to avoid causing damages to the thread.
3. Keep all hardware parts out of reach of children.

**NOTE :** THE LIST AND QUANTITY SHOWN ARE FOR 1 UNIT ASSEMBLY.  
Tool needed : Screwdriver (not provider).

PART LIST		
ITEM	DESCRIPTION	QTY
A	HEADBOARD	1 PC
B	FOOTBOARD	1 PC
C	SIDE RAIL	2 PCS
D	SLAT	4 PCS
E	SLAT	1 PC
F	SLAT WITH TRUNDLE	2 PCS
G	DRAWER PANEL	1 PC
H	DRAWER SUPPORT WOOD	3 PCS
I	BED SLAT	12 PCS
J	PANEL SUPPORT	2 PCS
K	CENTER SUPPORT	1 PC

HARDWARE LIST		
ITEM	DESCRIPTION	QTY
1	JCBC BOLT M6 x 35mm	13 PCS
2	JCBC BOLT M6 x 60mm	4 PCS
3	JCBB BOLT M8 x 40mm	8 PCS
4	M8 SPRING WASHER	4 PCS
5	M8 FLAT WASHER	4 PCS
6	BED SLAT SIDE FITTER	24 PCS
7	WOOD SCREW M4 x 38mm	16 PCS
8	WOOD SCREW M3.5 x 16mm	4 PCS
9	M4 ALLEN KEY (BALL SHAPE)	1 PC
10	M5 ALLEN KEY (BALL SHAPE)	1 PC

### STEP 1

Loosely fit bolt (3) into Headboard (A) & Footboard (B) as picture shown.

### STEP 2

### STEP 3

Follow the label direction to fix the support wood as picture shown.

### STEP 4

"TOP" label must be skyward as picture shown

# ASSEMBLY INSTRUCTIONS

STEP 5

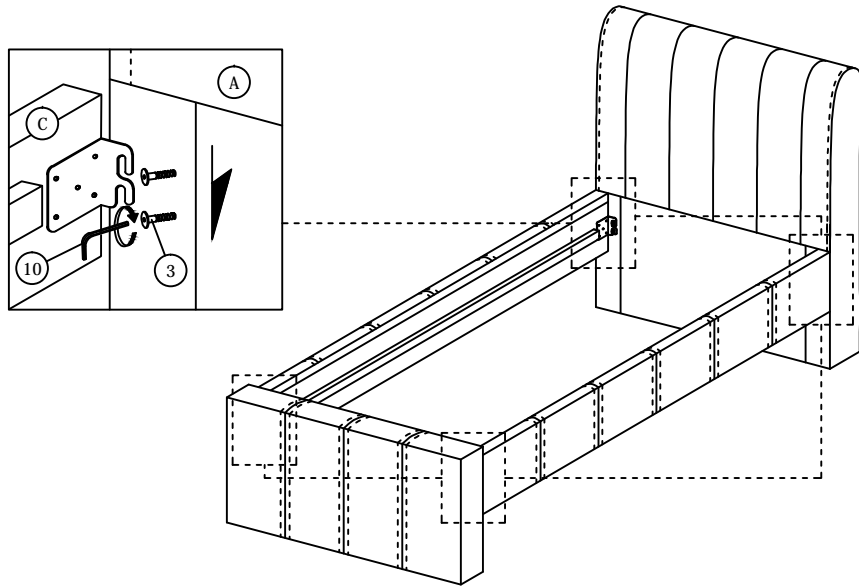

STEP 6

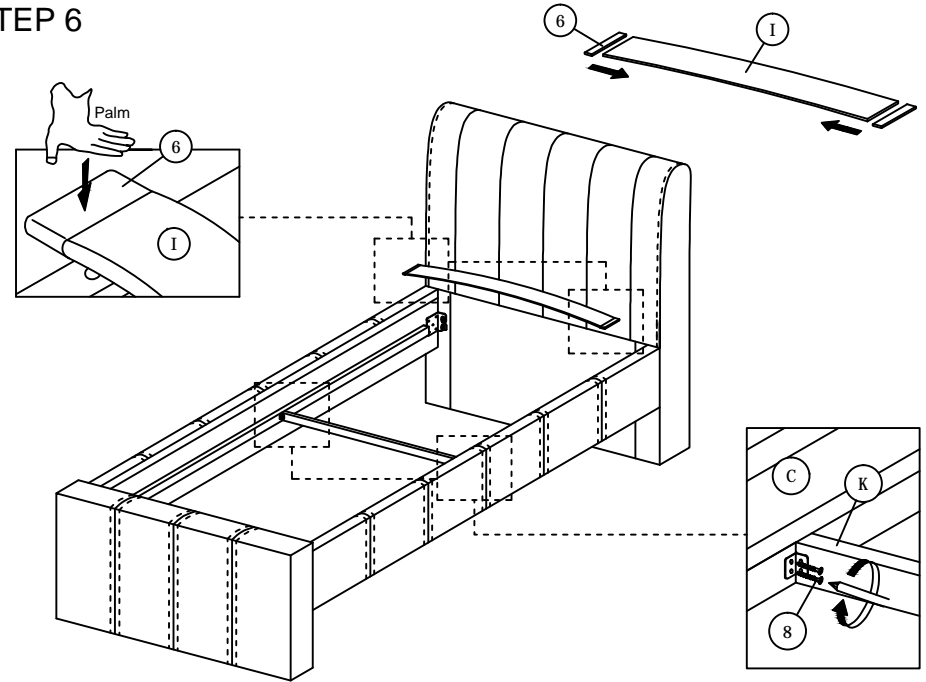

STEP 7

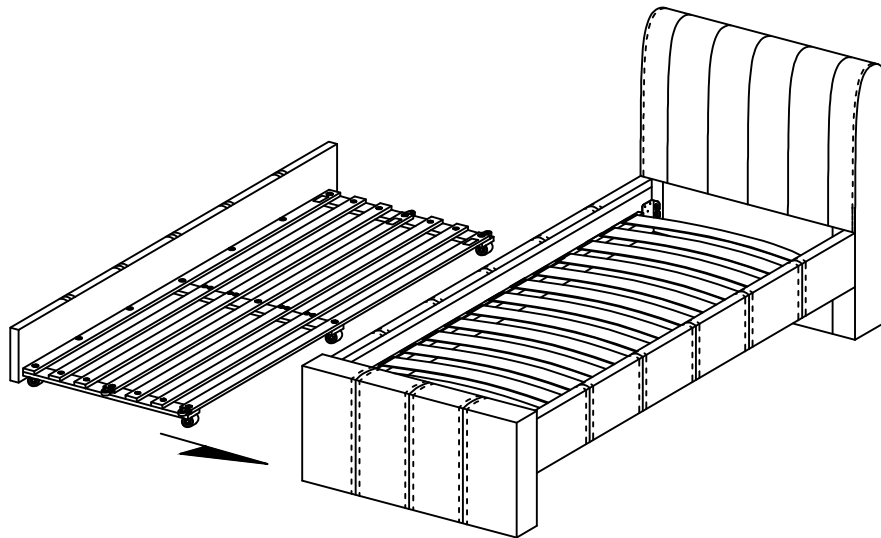

STEP 8

