

6 DRAWER DRESSER USER MANUAL

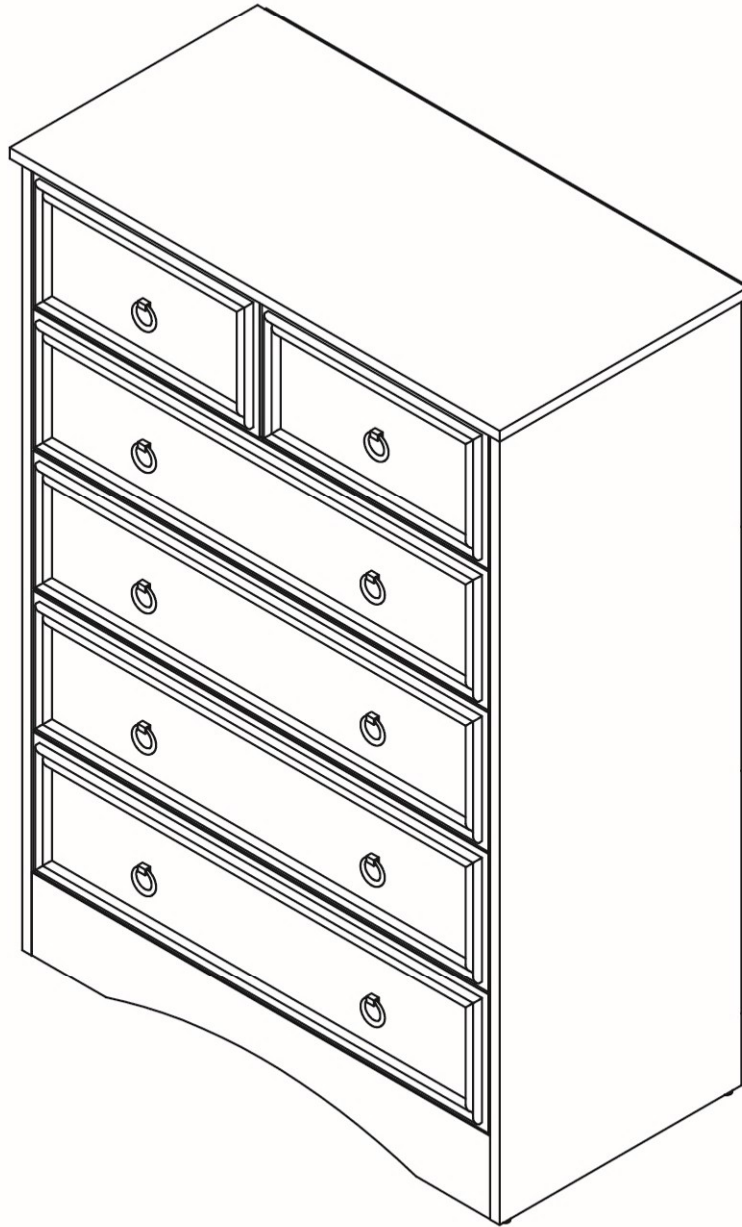

STRUCTURE FOR REFERENCE TO ASSEMBLY

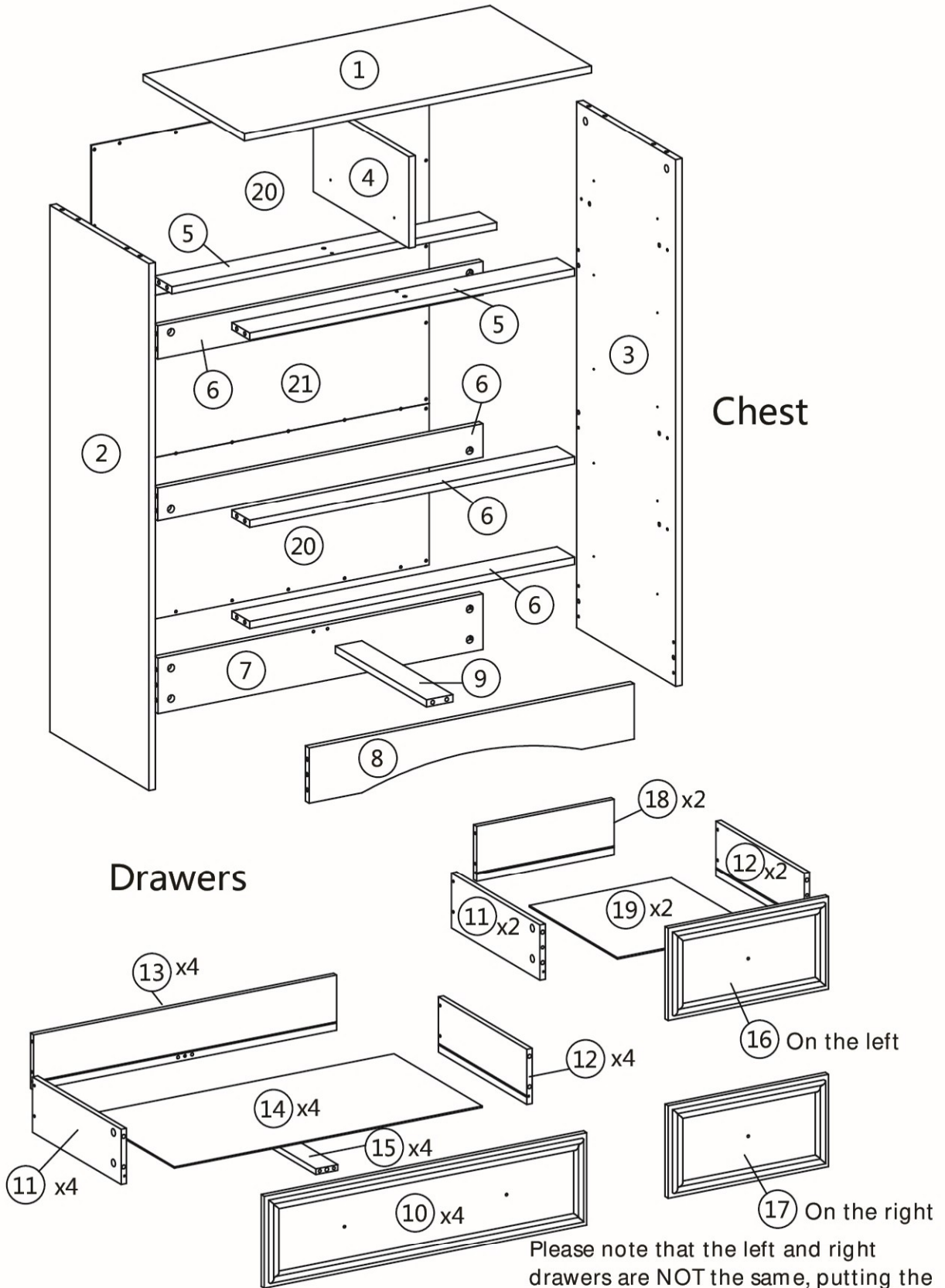









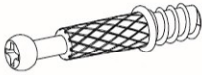

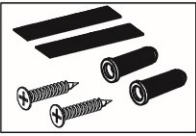

Chest

Drawers

Please note that the left and right drawers are NOT the same, putting the wrong location will lead to a more significant gap between the drawers.

List of Parts

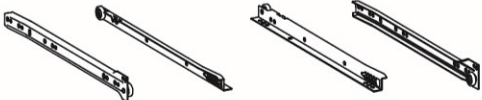
No.	Hare ware	Quantity
A		62+1
B		62+1
C		24+1
D		10
E		10
F		84+1
G		2
H		24+1
I		2
J		42+1
K		24+1
L		20+1
M		6

How the knock down (kd) assembly system works

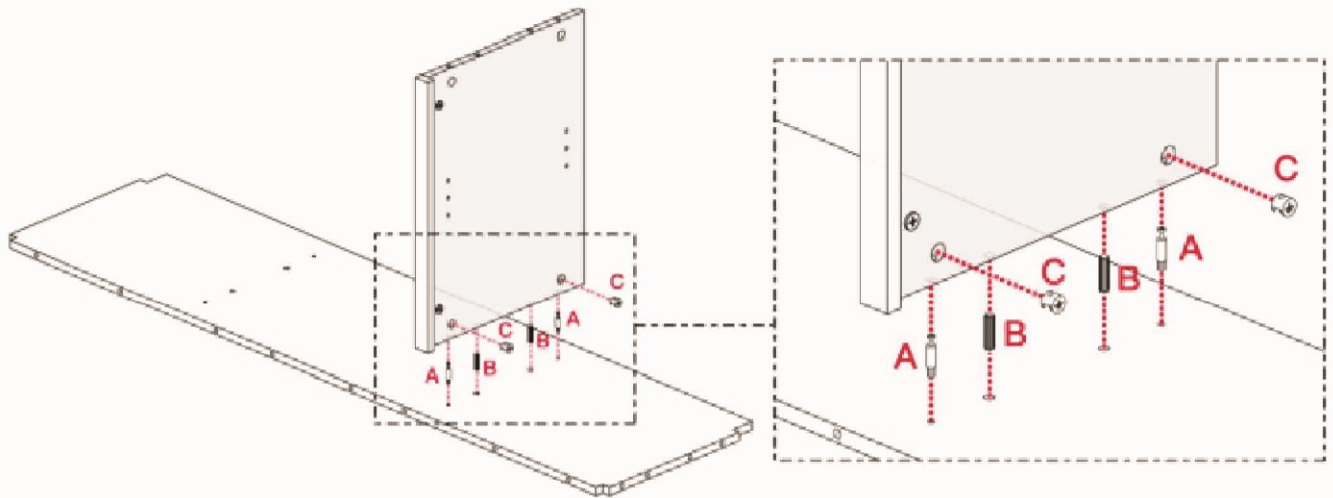

How to Install Wood Dowel

Insert the wood dowel [B] at least half way by tapping lightly with a rubber mallet, IF NECESSARY.



CAM LOCK SYSTEM OPERATION

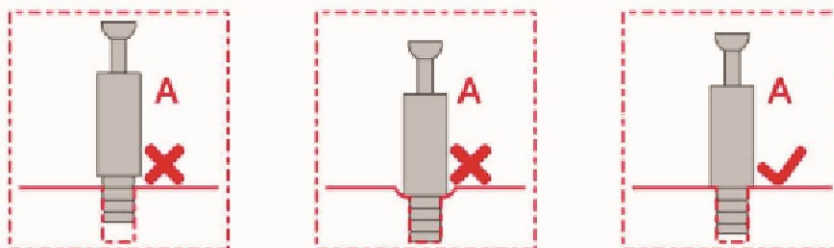

1. Screw the cam bolt [A] into the threaded insert on the panel.
2. Connect both panels together making sure cam bolt [A] goes into the pre-drilled large hole on the end of panel for cam lock [C].
3. Insert the cam lock [C] into the pre-drilled large hole on the panel. **Make sure the cross slot of cam lock [C] faces out.**
3. Rotate the cam lock [C] **clockwise** with a self-supplied phillips screwdriver to lock the cam bolt [A] in place.

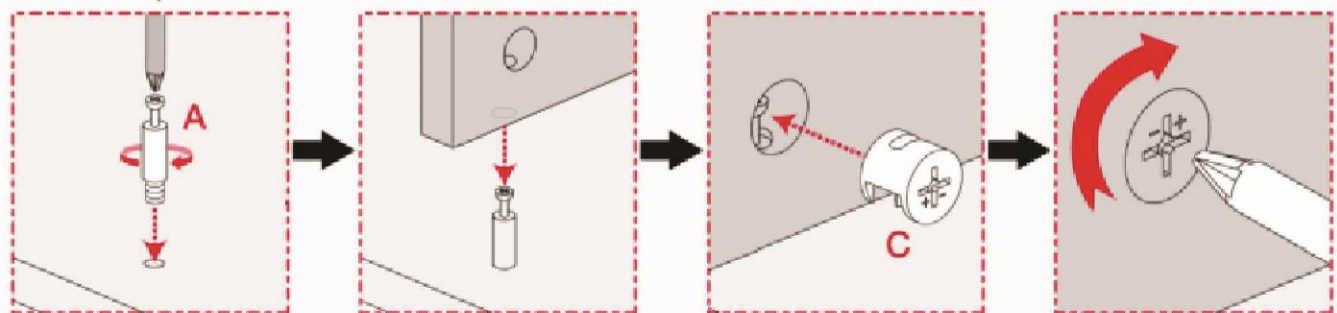

You are now ready to assemble the dresser

You are now ready to assemble the dresser

Before installation, observe each structure of the drawer dresser. The drawer dresser consists of two main parts. You will assemble the chest first, and then install the two small drawers and four larger drawers. Finally, look at the finished look, and contrast list of part, imagine how to install it faster, hope this will help you.

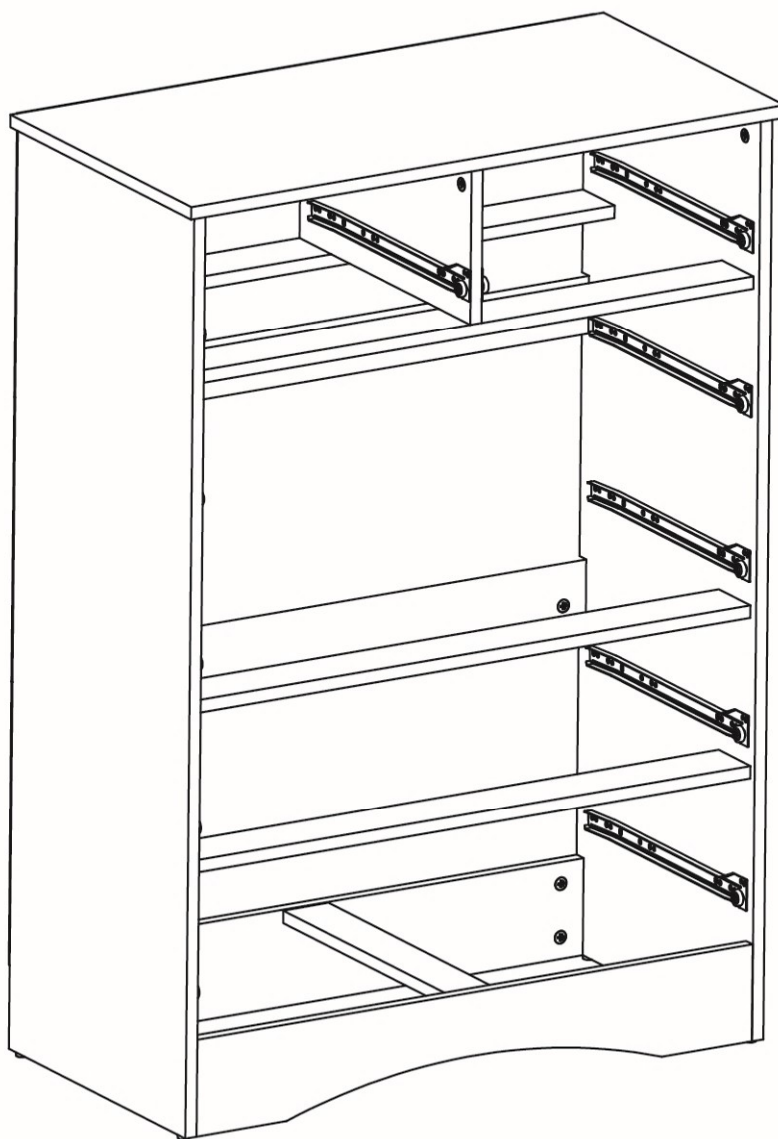

step 1-1

M



CL

5 PCS

F



15 PCS

- Install the drawer slides (M) on the left side panel (2).

When building it make sure to take note of the drawer slides is the one with a flat end.

Make sure the two large pre-drilled hole are on the upside.

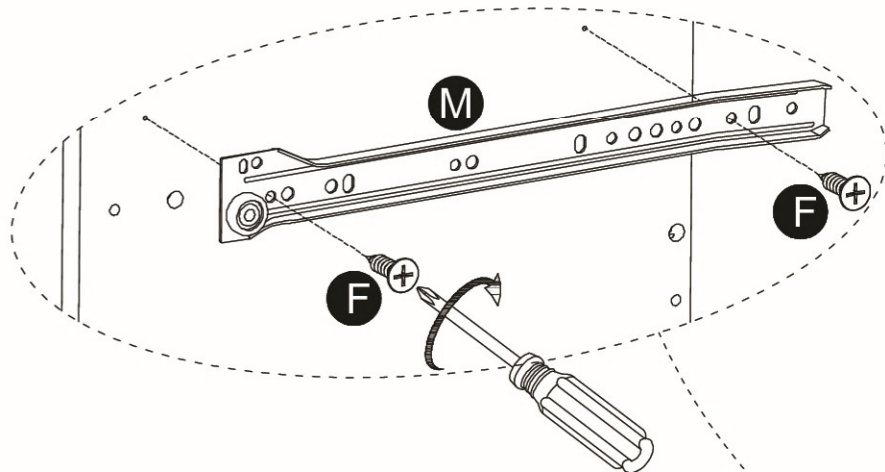

All the white wheels should be on the same side as the HORIZONTAL two adjacent small holes in the middle. And two adjacent small pre-drilled holes are for A screw and C wood stick to install reinforcement connect boards, not for F screw to install sliding rail. The white wheel is on the lower side.

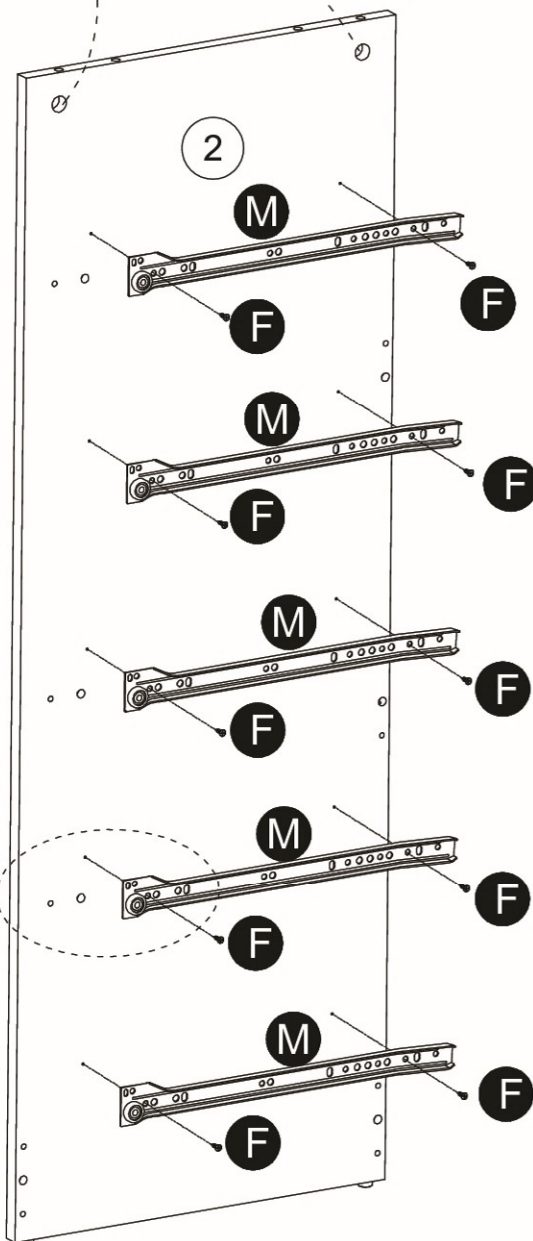

step 1-2

NOTE: When you screw the screws, please refer to the illustration carefully to make sure that the slide screws correspond to the position.

Fix the slide first: The LOWER row of holes of the slide has two corresponding pre-drilled holes. Start with the screw in the FIRST hole in the BELOW row holes of the slide closest to drawer face

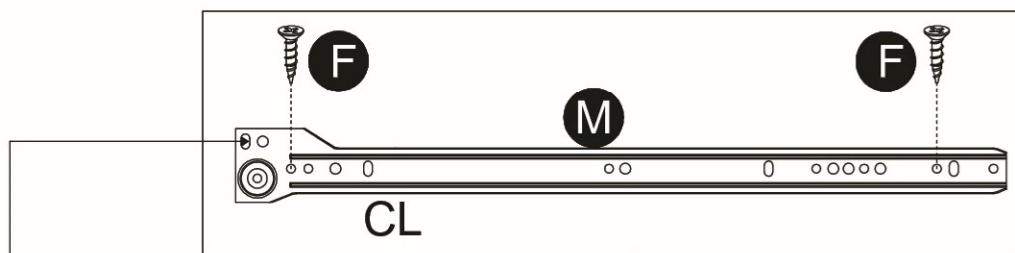

The first hole in the UPPER row holes of the slide is without the corresponding pre-drilled hole, after fix the position of the slide and then screw on.

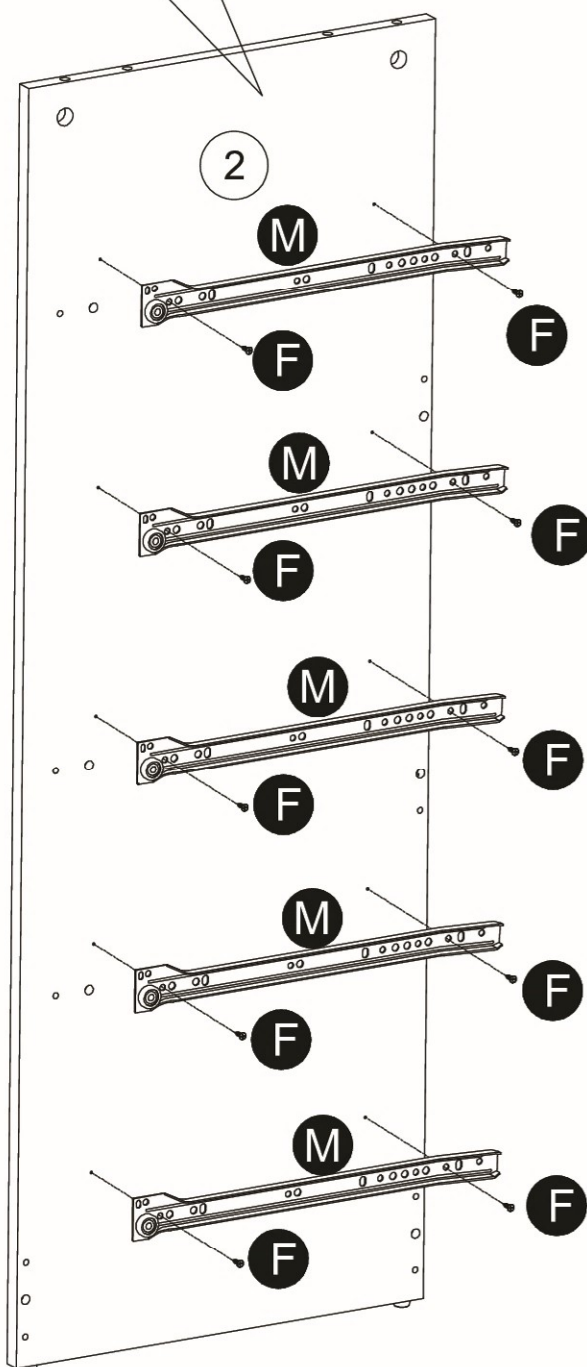

step 2-1

M



CR

5 PCS

F



15 PCS

- Install the drawer slides (M) on the Right side panel (3).

When building it make sure to take note of the drawer slides is the one with a flat end.

Make sure the two large pre-drilled hole are on the upside.

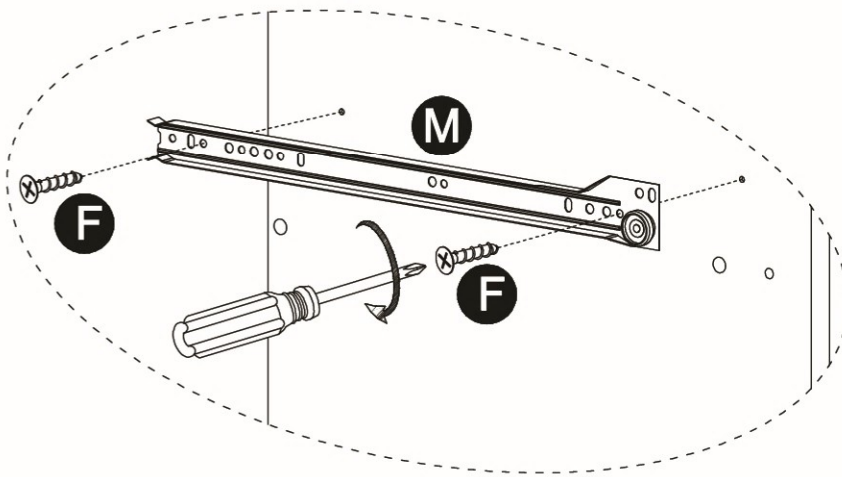

All the white wheels should be on the same side as the HORIZONTAL two adjacent small holes in the middle. And two adjacent small pre-drilled holes are for A screw and C wood stick to install reinforcement connect boards, not for F screw to install sliding rail. The white wheel is on the lower side.

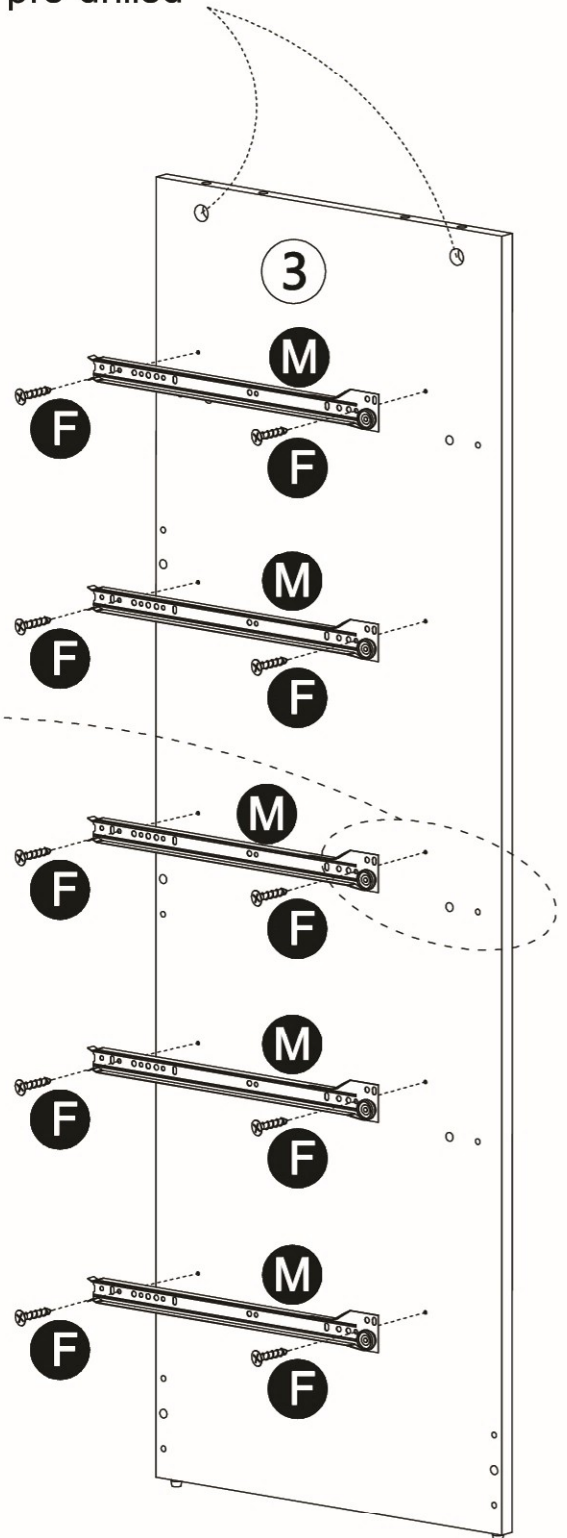

step 2-2

NOTE: When you screw the screws, please refer to the illustration carefully to make sure that the slide screws correspond to the position.

Fix the slide first: The LOWER row of holes of the slide has two corresponding pre-drilled holes. Start with the screw in the FIRST hole in the BELOW row holes of the slide closest to drawer face

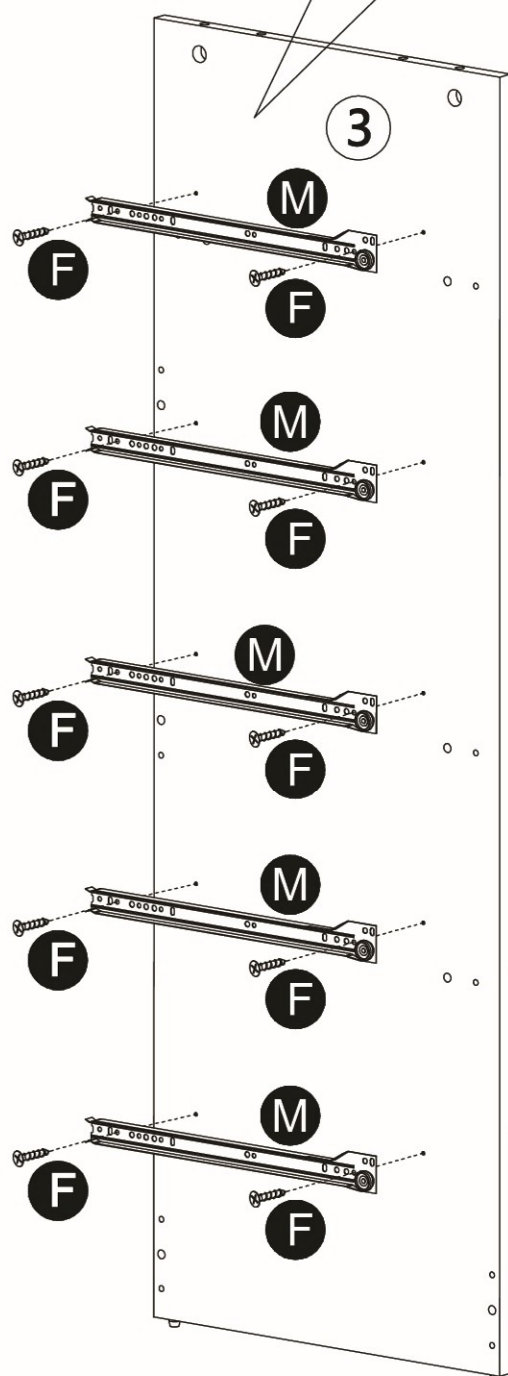
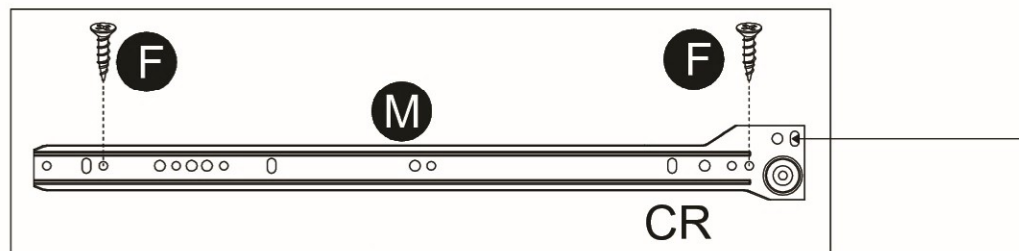

The first hole in the UPPER row holes of the slide is without the corresponding pre-drilled hole, after fix the position of the slide and then screw on.

step 3

M

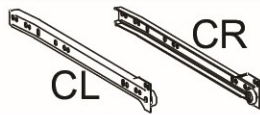

2 PCS

F



6 PCS

- Install the drawer slides (M) on the Middle panel (4).

When building it make sure to take note of the drawer slides is the one with a flat end. Fix the slide: The lower row of holes of the slide has two corresponding pre-drilled holes. Start with the screw in the FIRST hole in the BELOW row holes of the slide closest to drawer face.

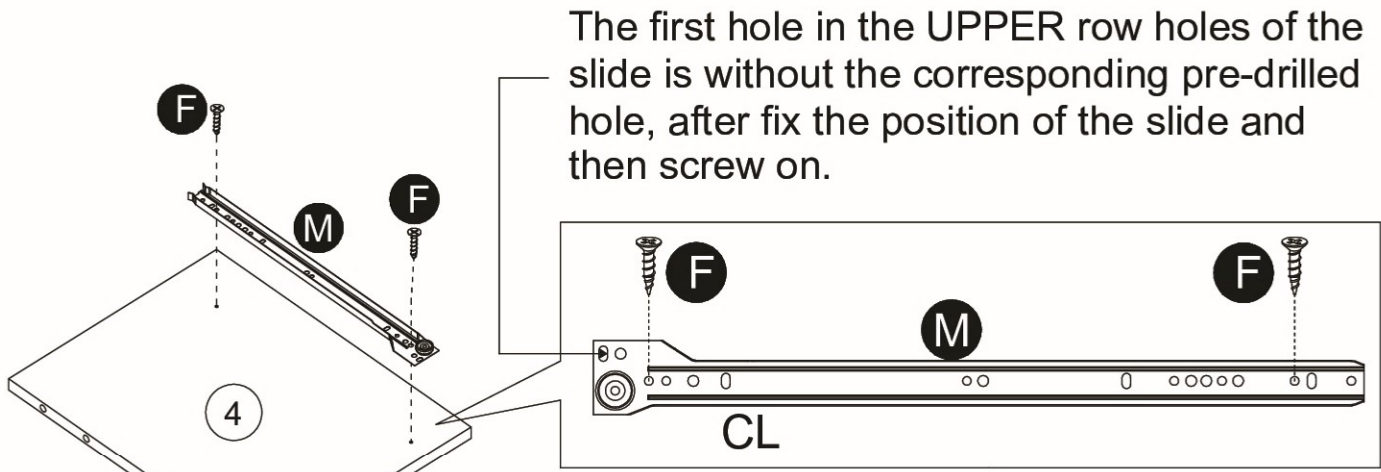

Install first rail on the right side of board 4.

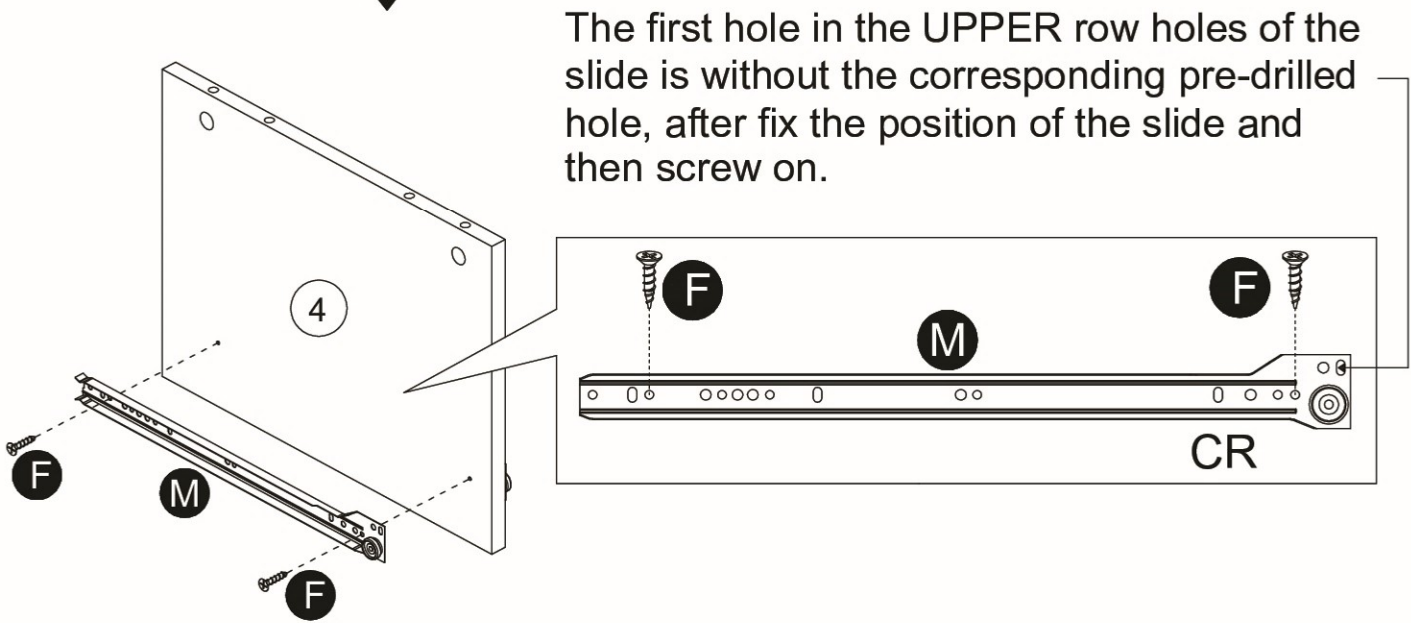

Install second rail on the left side of board 4.

STEP 4

A

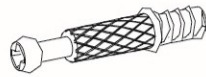

4 PCS

B



4 PCS

- Screw (A) to (7)&(8) as below shown
- Attach (9) to (7)&(8) below shown
- Refe to page 3: Cam lock system opertion

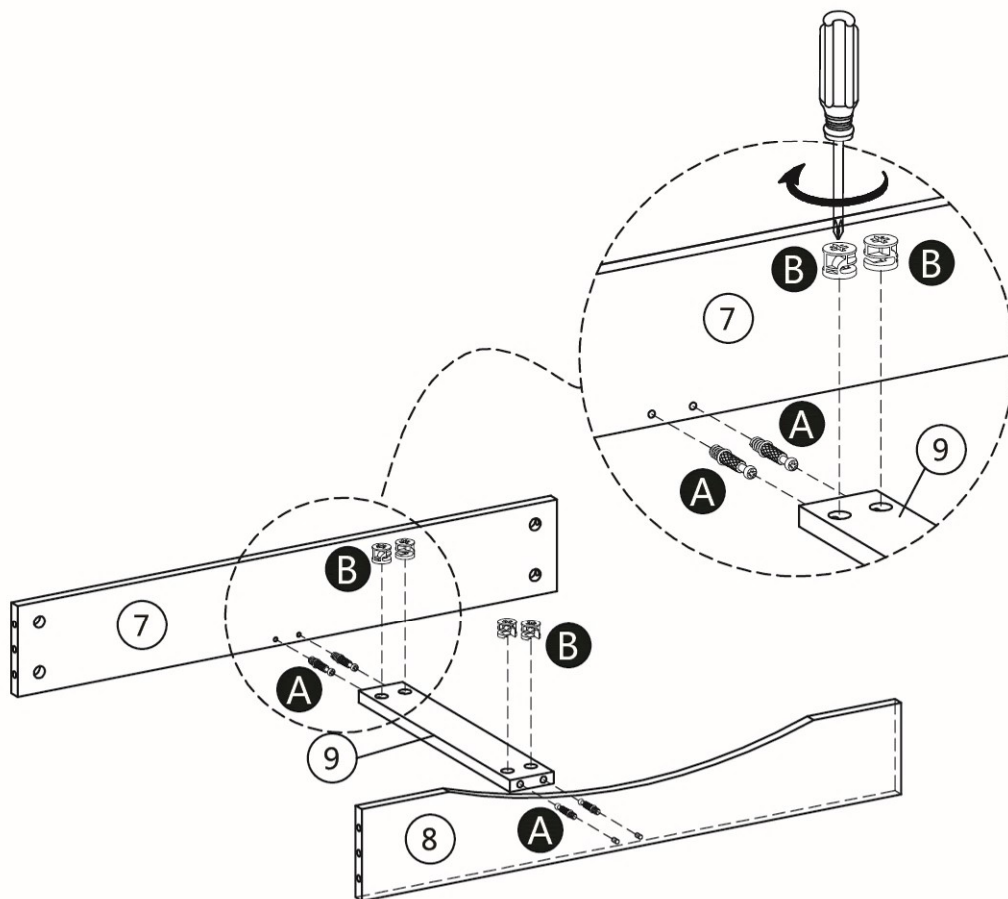
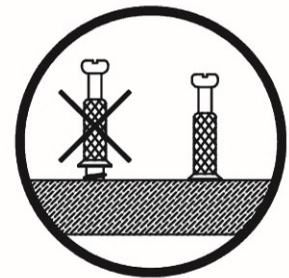
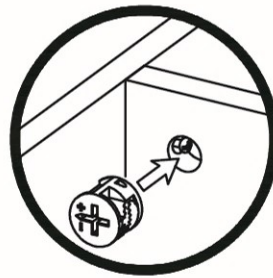

STEP 5

A

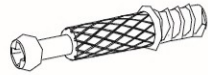

4 PCS

B



4 PCS

C



2 PCS

- Screw (A)&(C) to (3) as below shown
- Attach (7)&(8) to (3) below shown
- Refe to page 3: Cam lock system operation

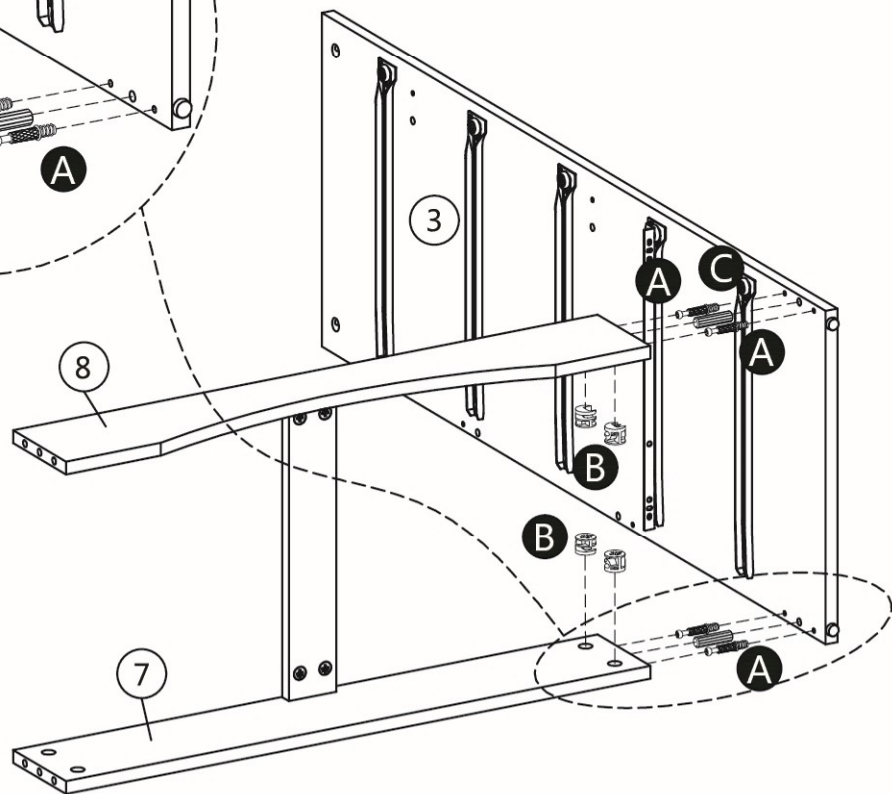
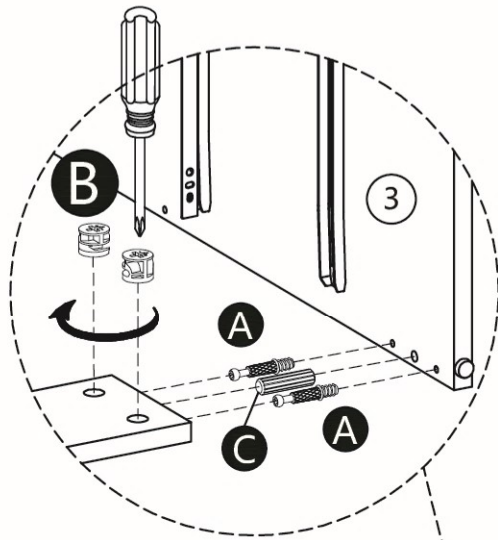
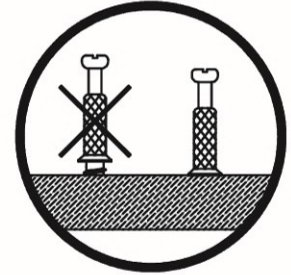
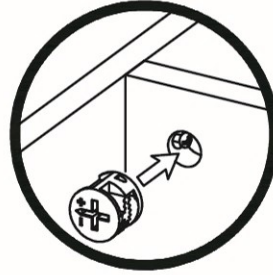

STEP 6

A

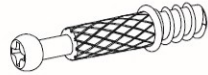

2 PCS

B



2 PCS

C



2 PCS

- Screw (A)&(C) to (3) as below shown
- Attach (5) to (3) below shown

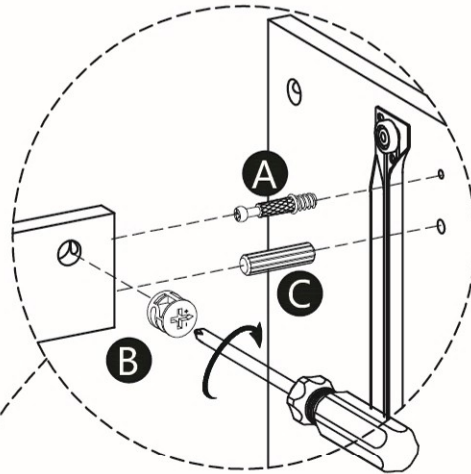
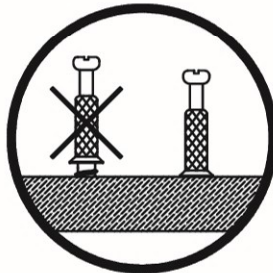
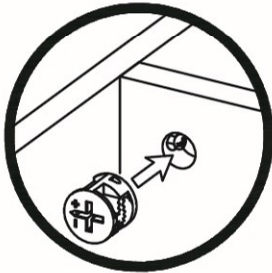

When building it make sure to take note of the direction of the small pre-drilled hole downward, and the small hole is used to install the top middle support plate so you know which way you are connecting them.

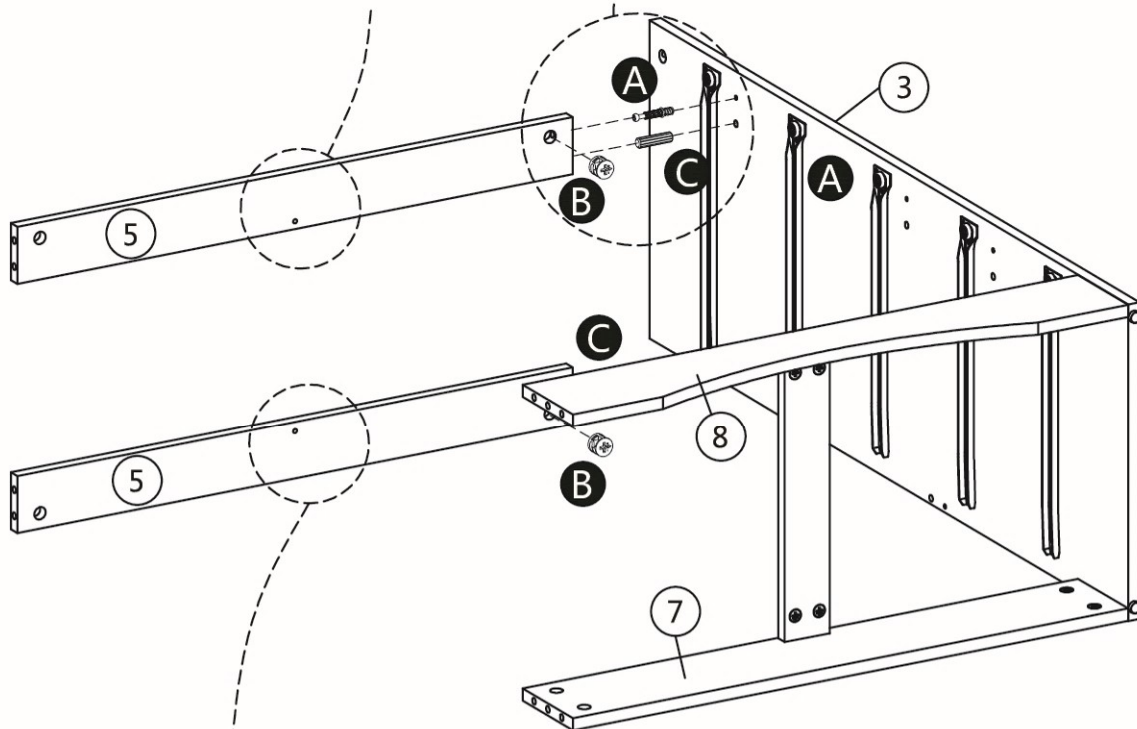

Consistent with the previous steps, when building it make sure to take note of the direction of the small pre-drilled hole downward, and the small hole here is symmetrical with the small hole in the previous step.

STEP 7

A

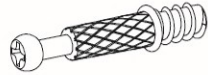

4 PCS

B



4 PCS

C



4 PCS

-Screw (A)&(C) to (3) as below shown
-Attach (6) to (3) below shown

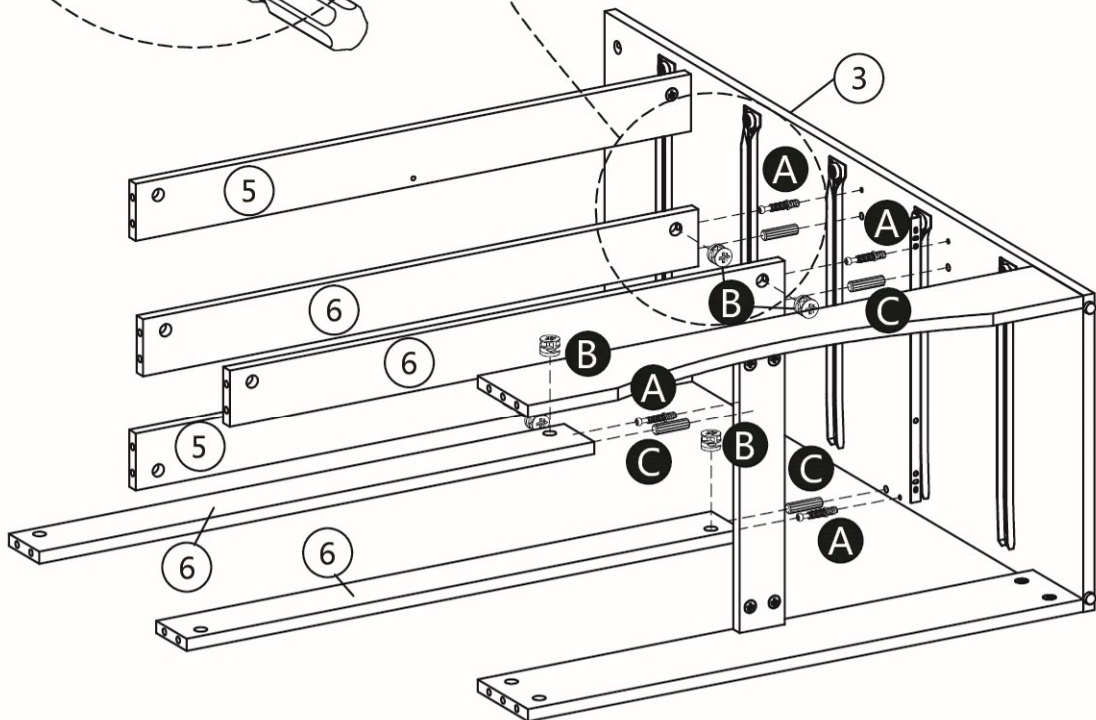
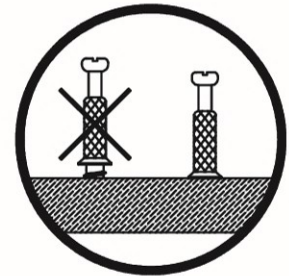
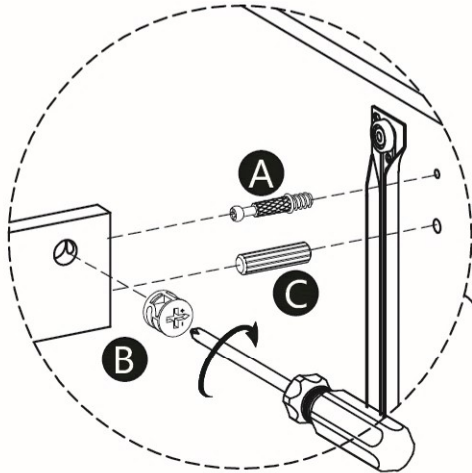

STEP 8

A

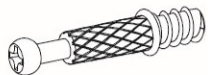

10 PCS

B



10 PCS

C



8 PCS

- Screw (A)&(C) to (2) as below shown
- Attach (5)&(6) to (2) below shown

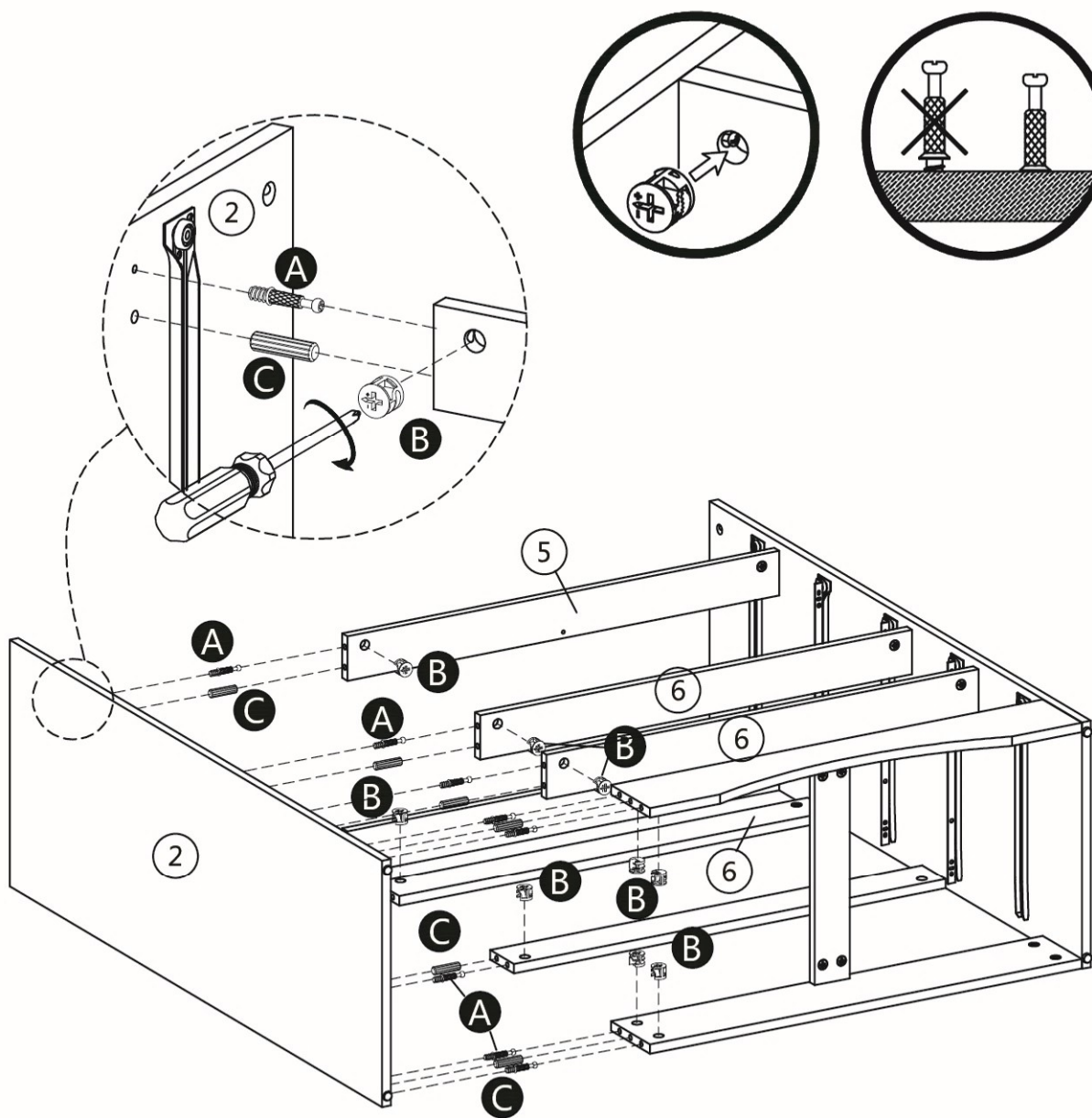

When assembling (2) board. Insert A sticks and C sticks in the (2) board first, then align all the pre-drilled holes and put them together gently. Finally use the B nut to tighten with A.

STEP 9

C



2 PCS

I



2 PCS

- Screw (C)& (I) to (4) as below shown
- Attach (4) to (5) below shown

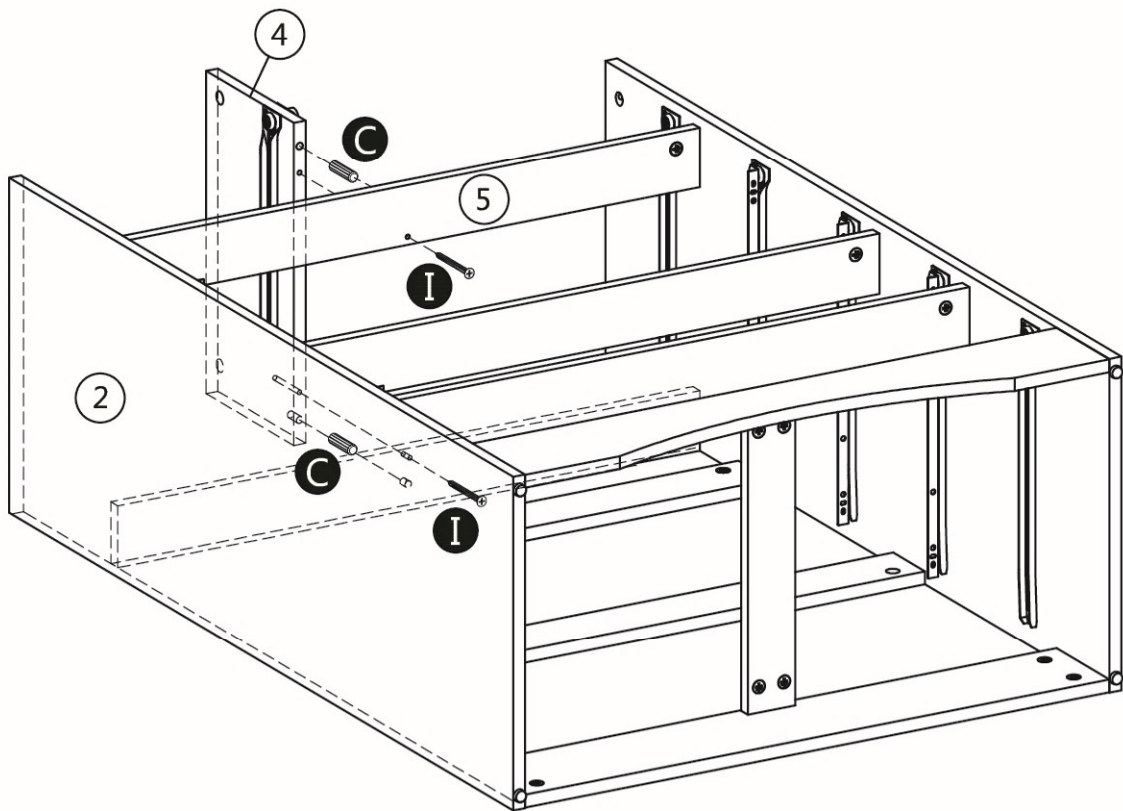

STEP 10

A

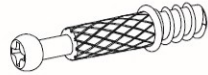

6 PCS

B



7 PCS

C



6 PCS

-Screw (C) to (2) & (3) as below shown

-Screw (A) to (1) as below shown

-Attach Top panel (1) to Side boards (2) & (3) & (4) as below shown

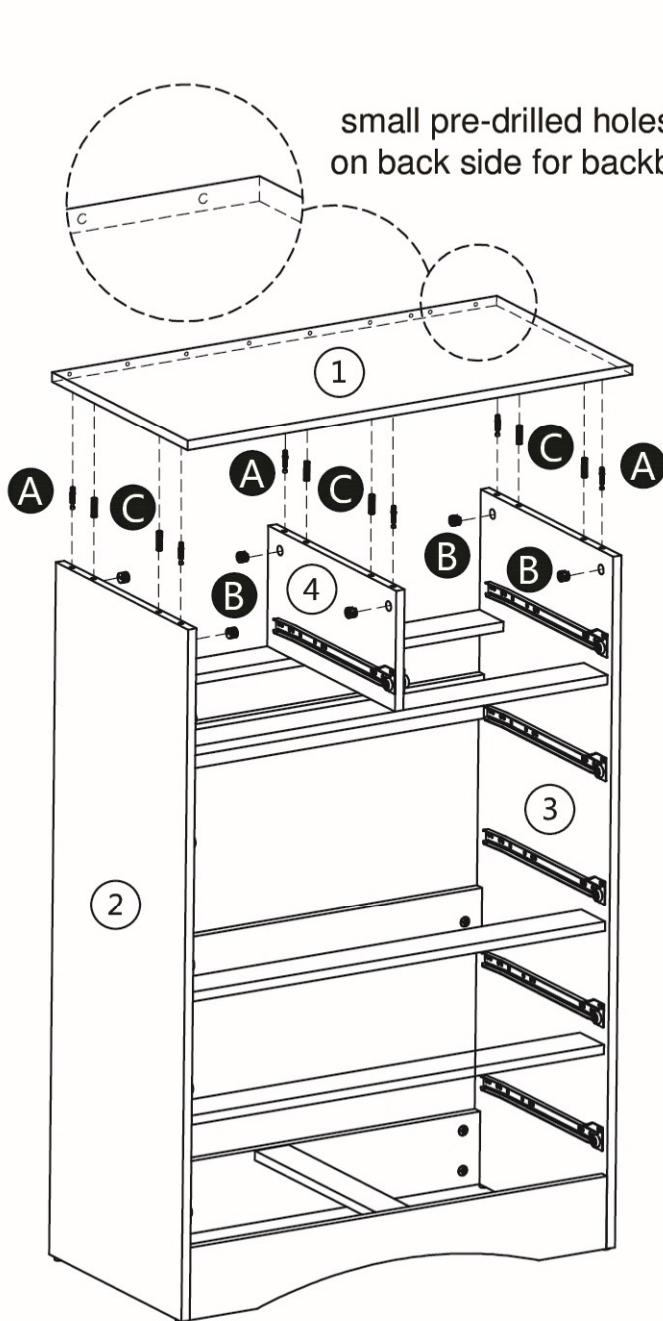

small pre-drilled holes
on back side for backboard.

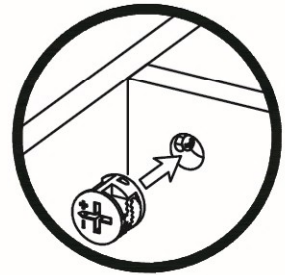
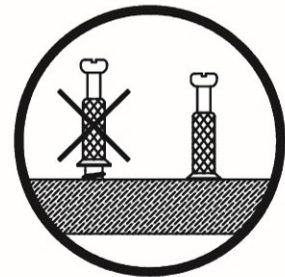

STEP 11

J



42 PCS

-Screw (J) to Back panel (20)&(21) as below shown

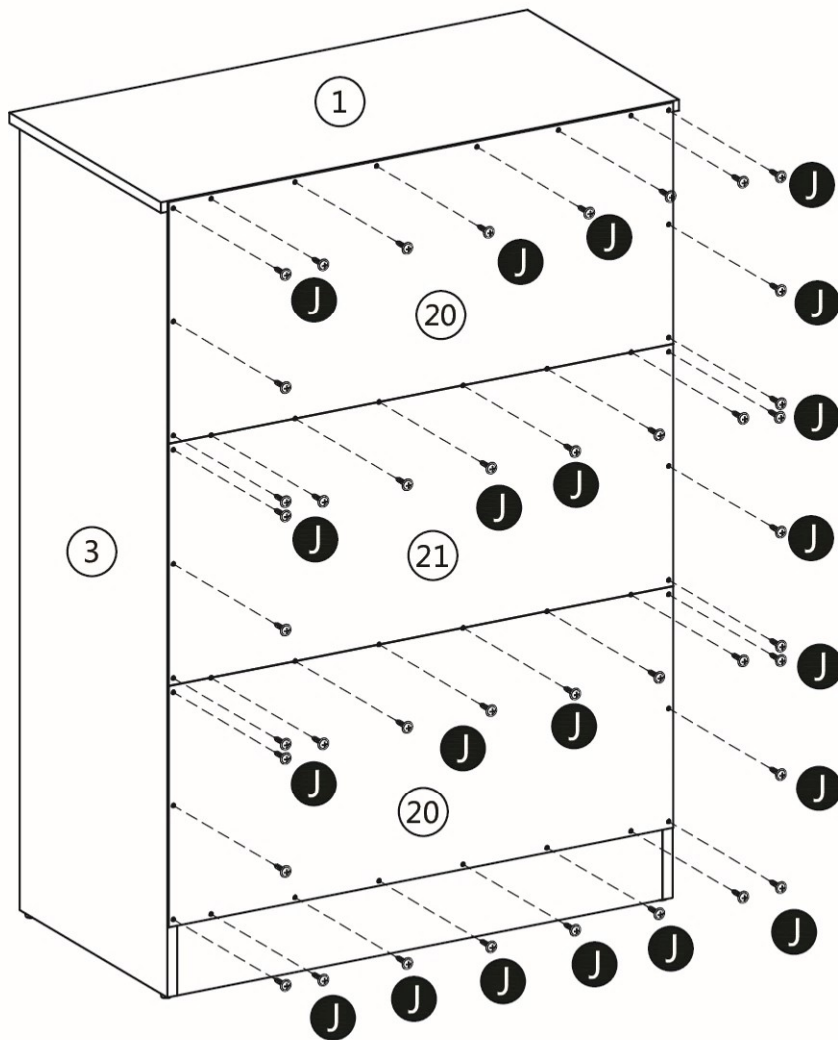

WARM TIPS :It is recommended to attach the back panel (20) at the top panel (1) first.Please remember not to fully tighten all the screws (J) until all of them are in correct position.

STEP 12

H



8 PCS

- Screw (H) to (18) as below shown
- Attach(11) & (12) to (18) as below shown

The long groove is used to install the bottom plate, make sure to take note of installing the grooves of these boards on the same side.

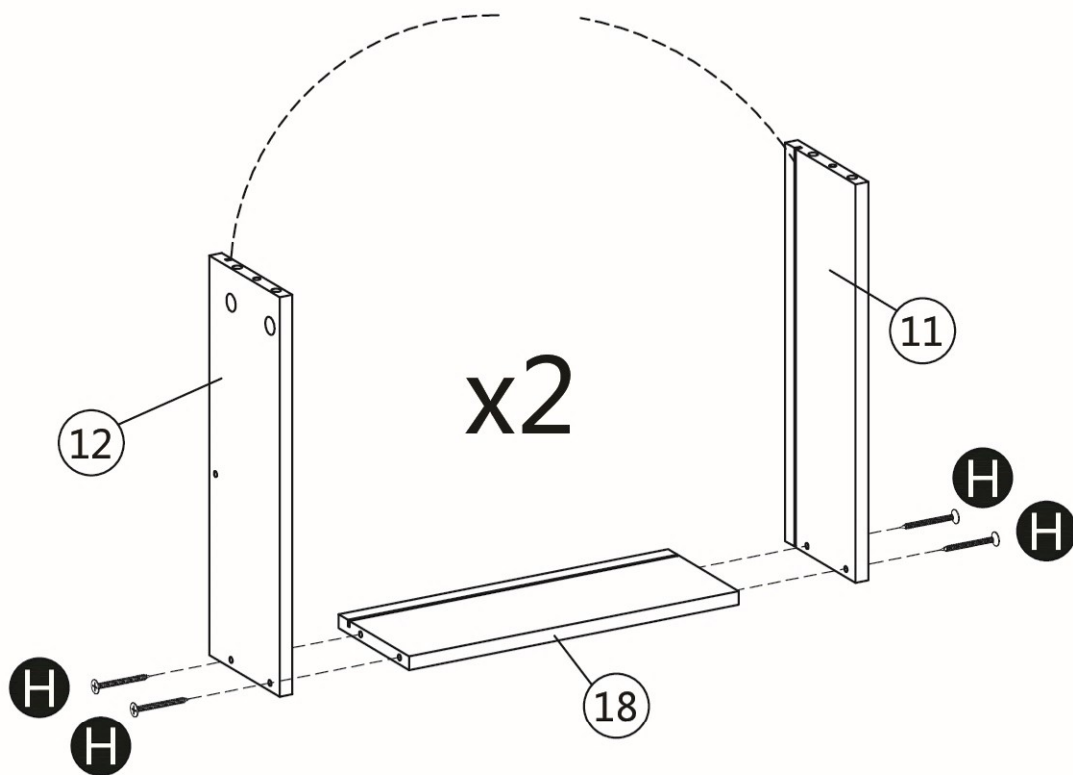

Start assembling the small drawer.

STEP 13

A

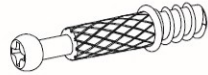

8 PCS

B



8 PCS

L



4 PCS

-Screw (A) & (L) to (16) & (17) as below shown

-Attach(16) & (17) & (19) to (11) & (12) & (18) as below shown

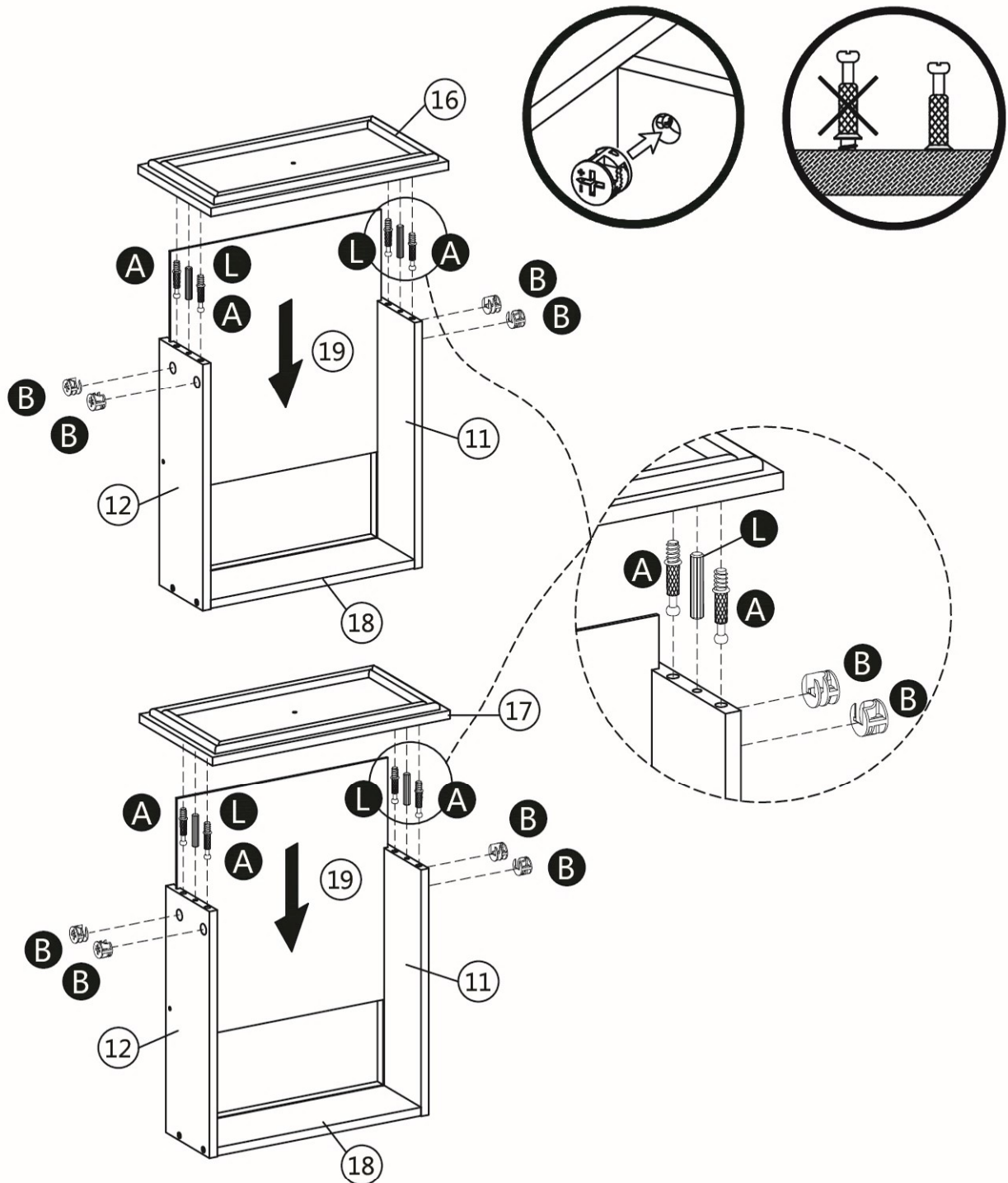

STEP 14

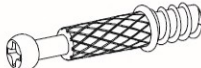
A  4 PCS

B  4 PCS

H  16 PCS

L  4 PCS

- Screw (A) & (H) & (L) to (13) as below shown
- Attach(11) & (12) & (15) to (13) as below shown

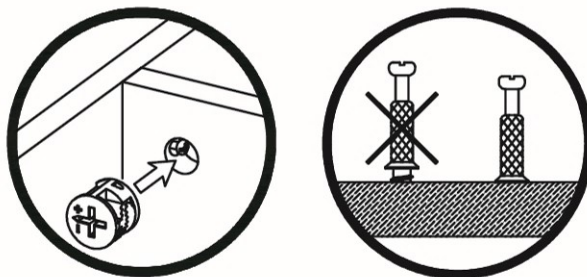

The long groove is used to install the bottom plate, make sure to take note of installing the grooves of these boards on the same side.

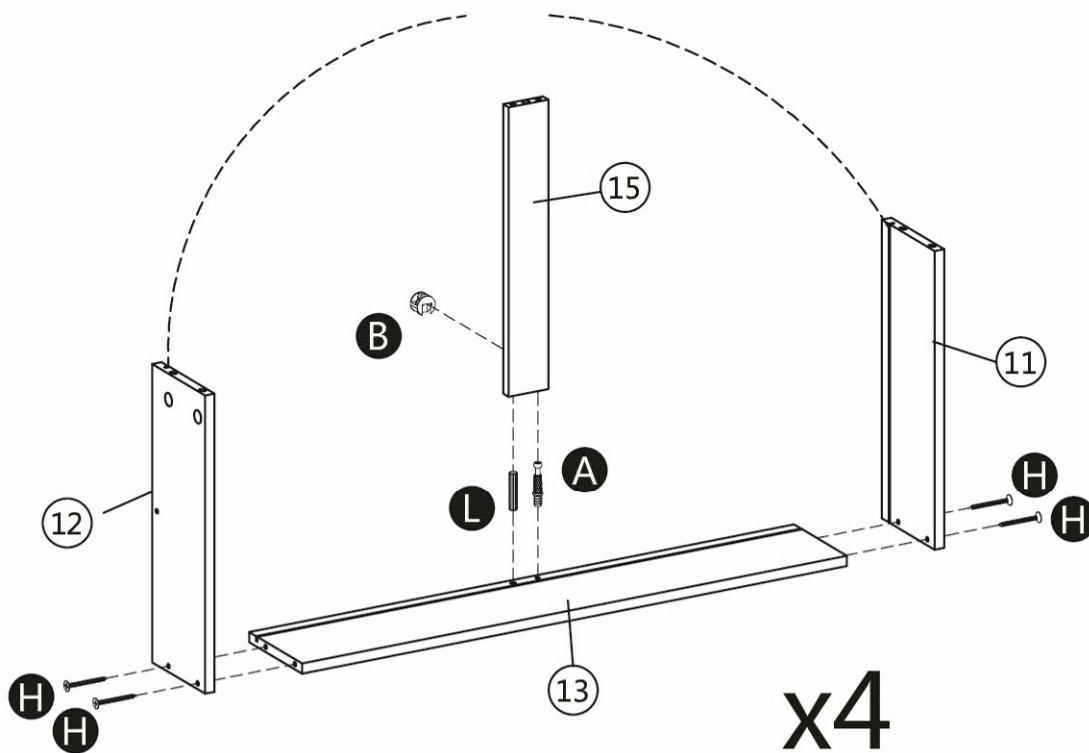

Start assembling the large drawer.

STEP 15

A

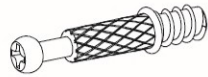

20 PCS

B



20PCS

L



12 PCS

-Screw (A) & (L) to (10) as below shown

-Attach(10) & (14) to (11) & (12) & (13) as below shown

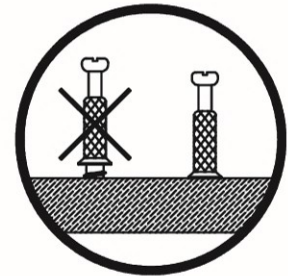

x4

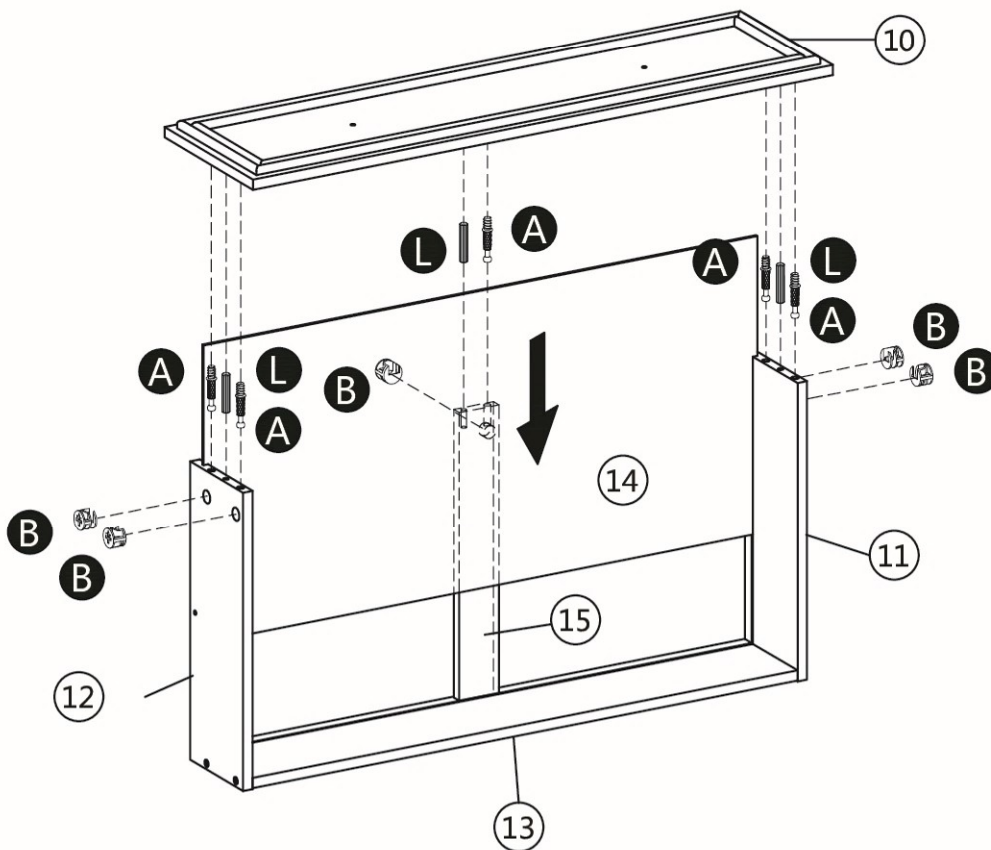

STEP 16

D



10 PCS

E

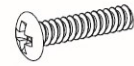

10PCS

-Screw (D) & (E) to (10) & (16) & (17) as below shown

They are not the same, and getting them mixed up will cause the drawers stick out and remain open can not close shut.

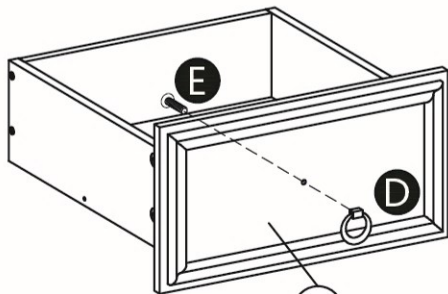

16 Left drawer

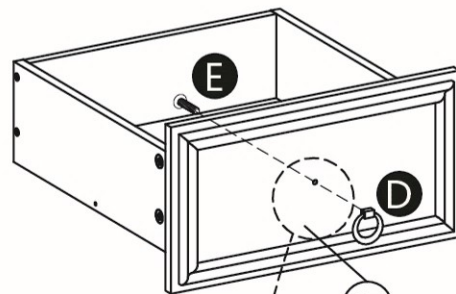

17 Right drawer

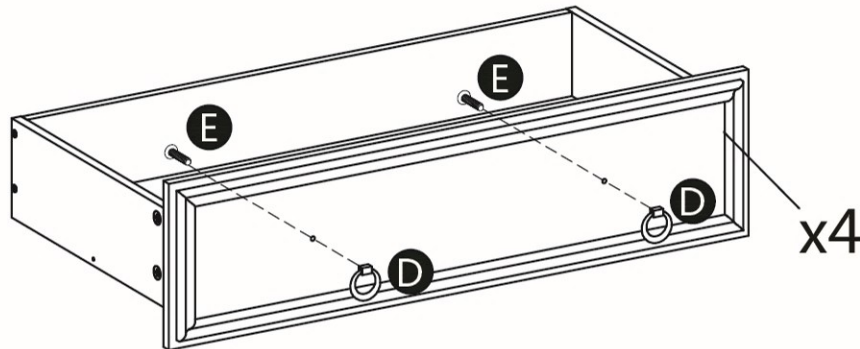
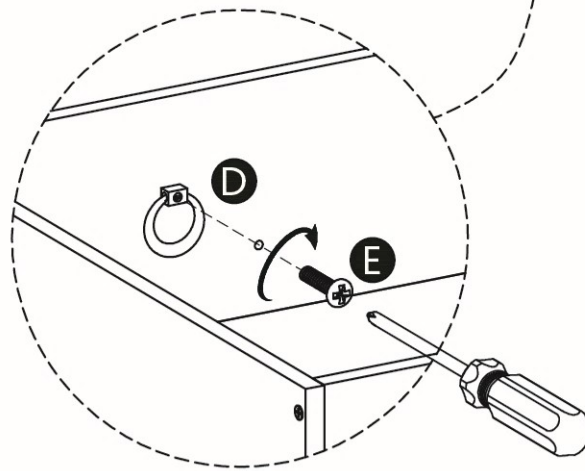

Insert screw E first, then align the pre-drilled holes of the pull, and tighten the screws.

STEP 17

M

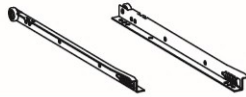

6 PCS

F



48 PCS

-Install the drawer slides (M) on the drawer side panels (11) & (12) as below shown

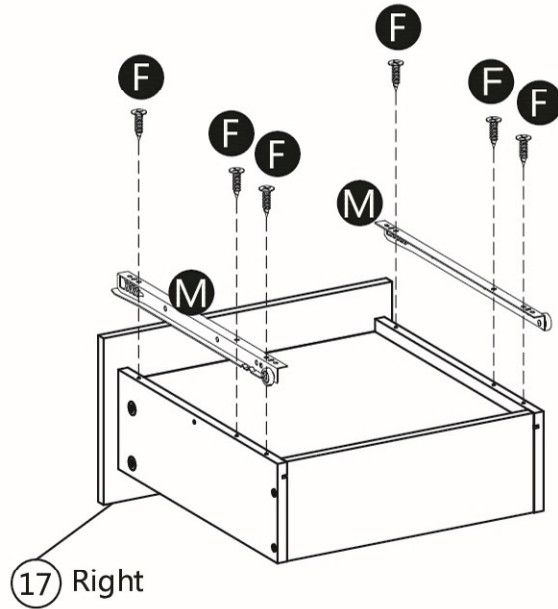
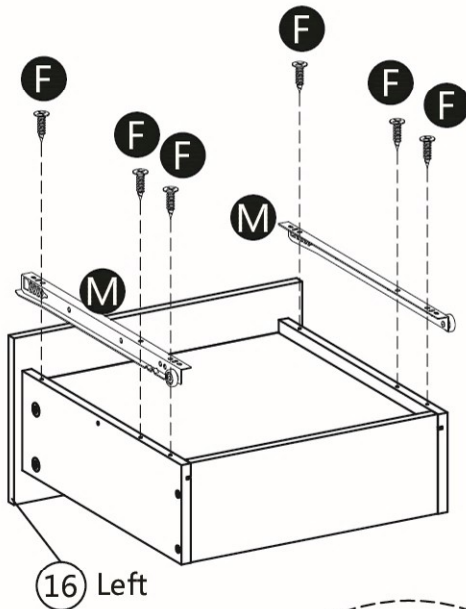

When building it make sure to take note of the drawer slides is the one similar to Z shape.

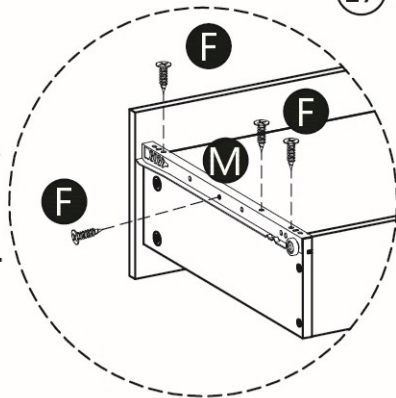

If necessary, install another screw in the middle of the drawer slide.

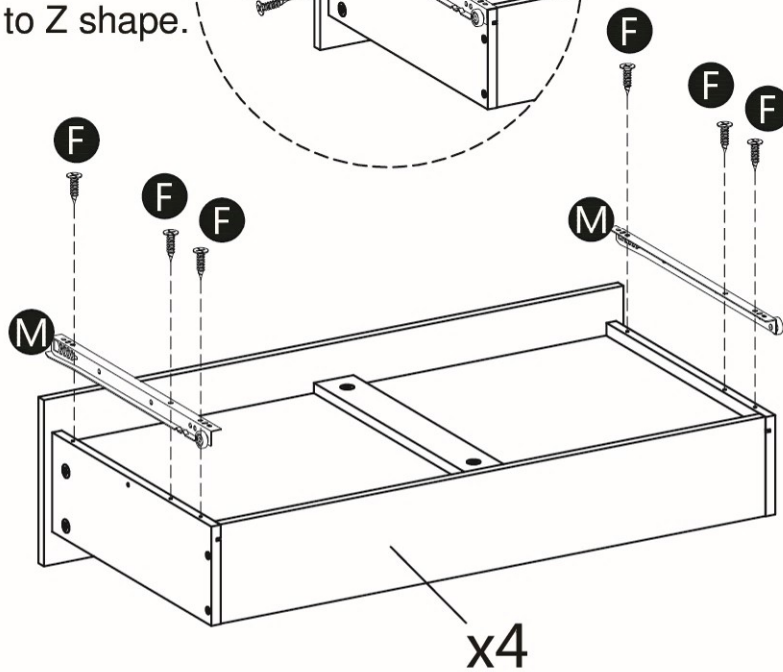

Repeat the previous step to install the remaining drawers

STEP 18

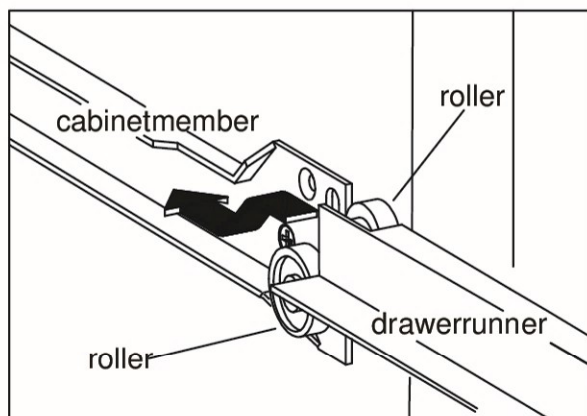
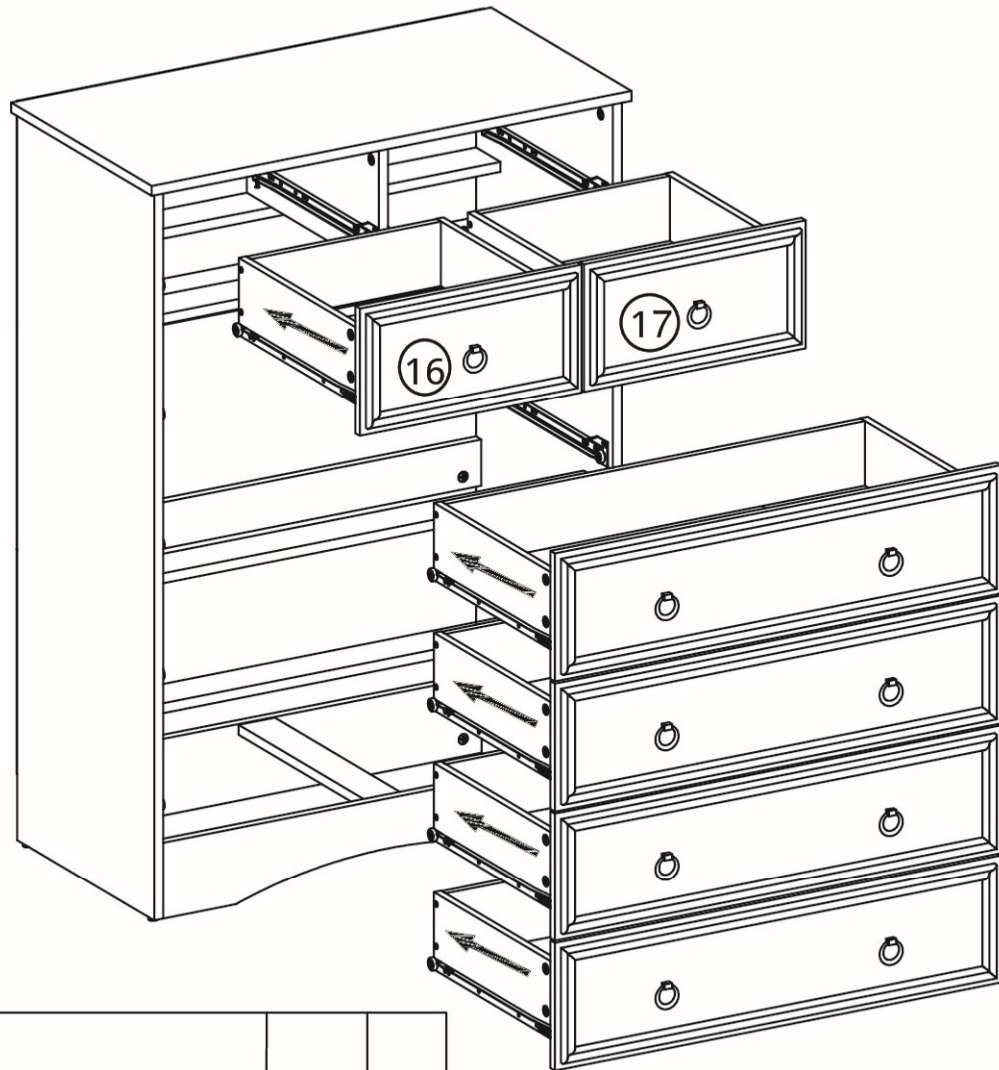

When you put the drawer, please note that the drawer wheels on top of the wheels of the slide, then check whether the drawer is smooth when pulled out. Otherwise, the drawer will not be aligned with other drawers.

Maximum Loads

This unit has been designed to support the maximum loads shown. Exceeding these load limits could cause sagging, instability, product collapse, and/or serious injury.

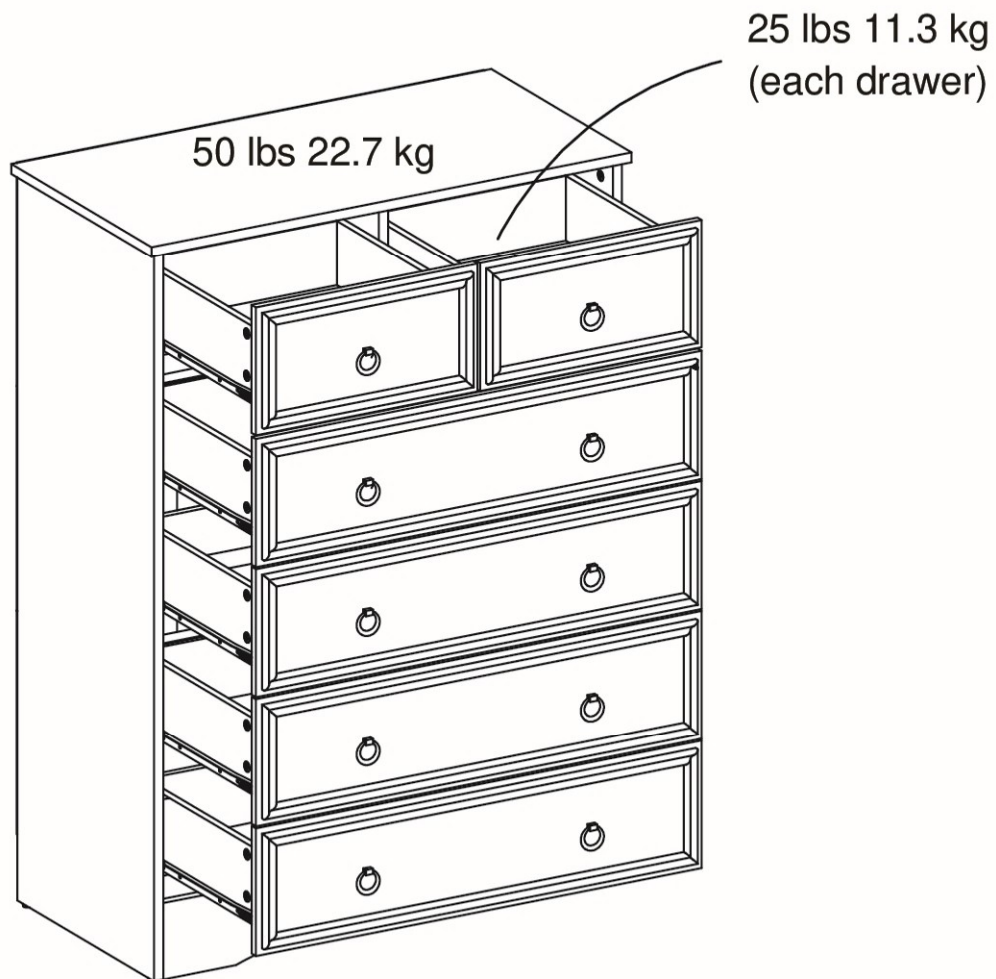

Assembly Instructions

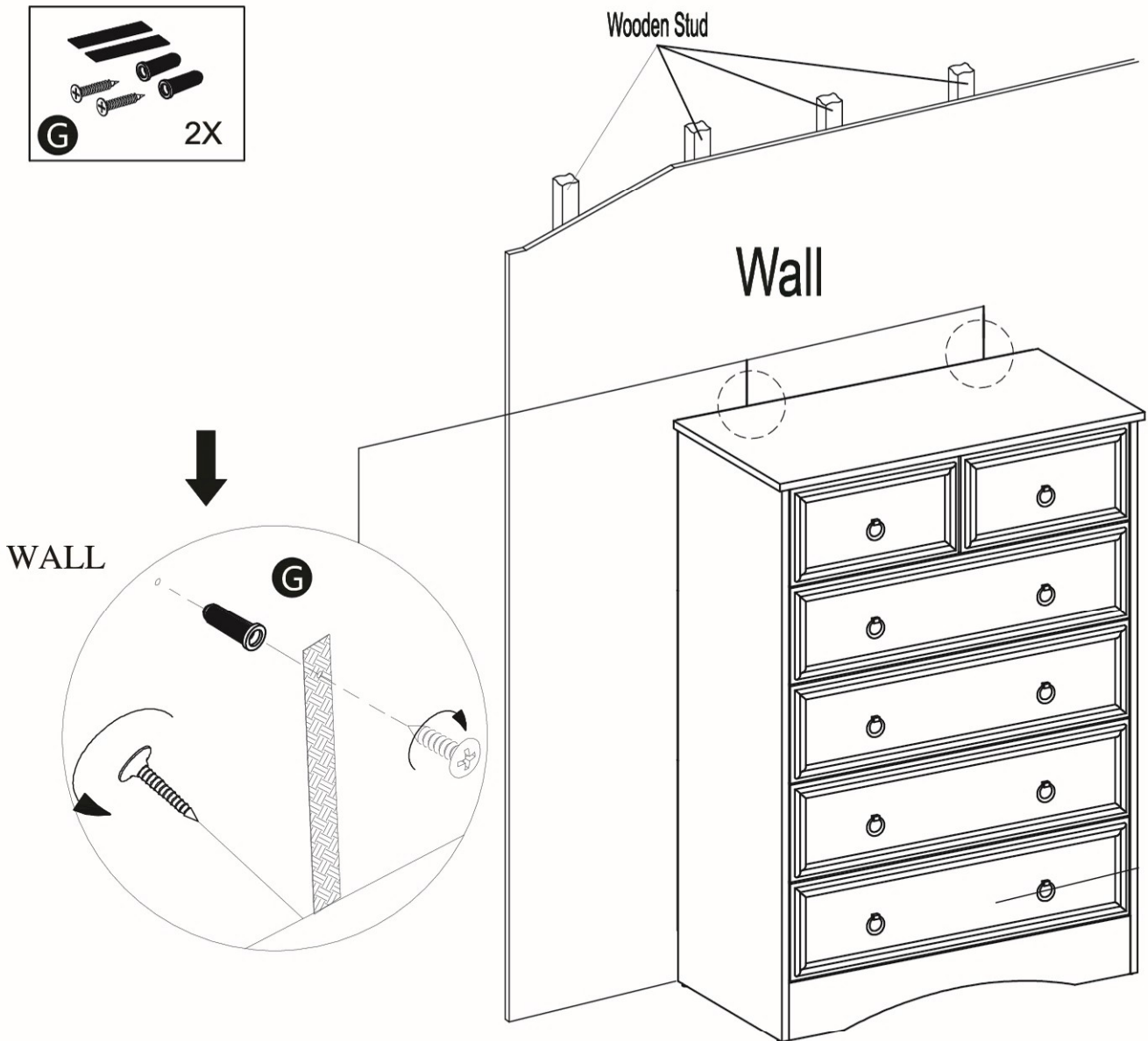

Tools required (not included): phillips screwdriver, stud finder, tape measure, pencil, power drill and 3/16" drill bit.

Now, follow the instructions printed on the plastic bag containing the tipping restraint hardware to attach the tip-over restraints to the unit and the wall.

NOTE: The tipping restraint hardware included is for wooden stud wall construction. it must be attached to a wall stud. depending upon your wall construction, different anchor hardware maybe required. please contact your local hardware store for assistance. young children can be seriously injured by tipping furniture. you must install the tipping restraint hardware with the unit to prevent the unit from tipping, causing any accidents or damage. the tipping restraints are intended only as a deterrent, they are not a substitute for proper adult supervision. the tipping restraints are not earthquake restraints. if you wish to add the extra security of earthquake restraints, they must be purchased and installed separately.

FINAL

Great, you got a 6 drawer dresser!

