













Assembly Instruction

⚠ WARNING:

- Read all instructions carefully and completely before assembly and use.
- Retain for future reference.
- DO NOT use power tools.
- DO NOT over-tighten hardware.
- Periodically check all hardware and re-tighten as necessary.
- DO NOT use product if any component becomes damaged.
- For residential (non-commercial) use only.
- DO NOT sit or stand on product. Use only for intended purpose.
- DO NOT exceed 80lbs for the tabletop and 30lbs for the shelf, evenly distributed.

Parts List

Check all parts before assembly

<p>A. <u>Tabletop</u></p>  <p style="text-align: right;">*1</p>	<p>B. <u>Body</u></p>  <p style="text-align: right;">*1</p>	<p>C. <u>Shelf</u></p>  <p style="text-align: right;">*1</p>	<p>D. <u>Back panel</u></p>  <p style="text-align: right;">*1</p>
<p>E. <u>Leg</u></p>  <p style="text-align: right;">*4</p>	<p>H1. <u>Hex bolt</u></p>  <p style="text-align: right;">*4(+1 extra)</p>	<p>H2. <u>Washer</u></p>  <p style="text-align: right;">*4</p>	<p>H3. <u>Foot pad</u></p>  <p style="text-align: right;">*4</p>
<p>H4. <u>Shelf pin</u></p>  <p style="text-align: right;">*4</p>	<p>H5. <u>Alley key</u></p>  <p style="text-align: right;">*1</p>	<p>H6. <u>Hex bolt</u></p>  <p style="text-align: right;">*4(+1 extra)</p>	<p>H7. <u>Hex bolt</u></p>  <p style="text-align: right;">*4(+1 extra)</p>

Step 1: Unfold the left panel and right panel and bottom panel from Body (B) as below.

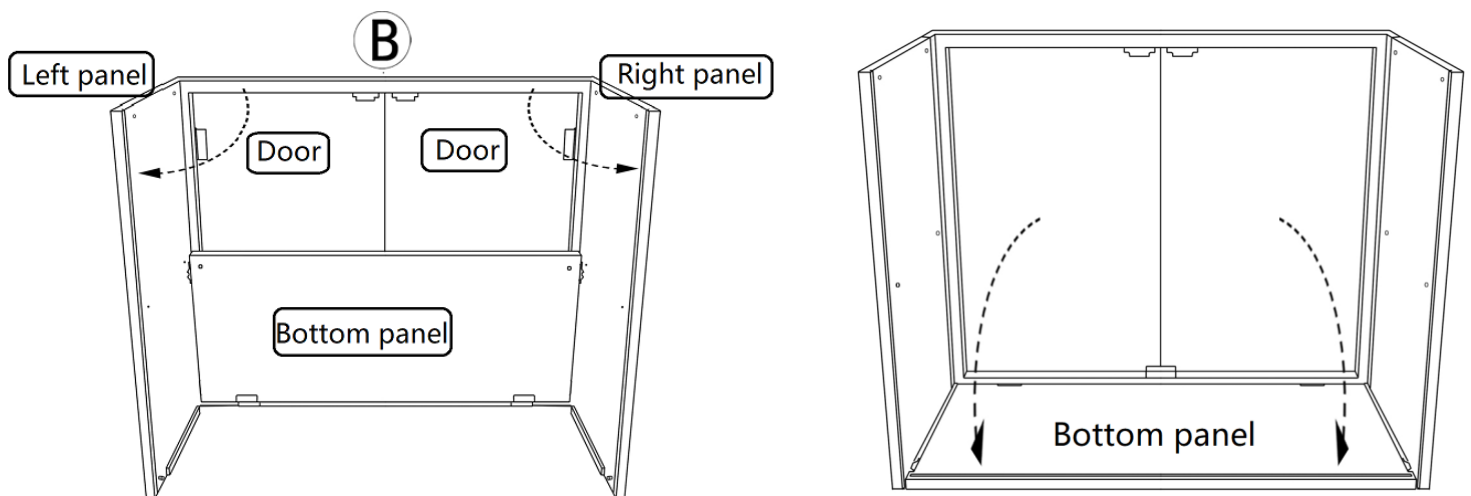

Step 2: Insert Attach Back panel (D) as shown in picture below. Ensure the Back panel (D) with the groove on Left&Right panel (B).

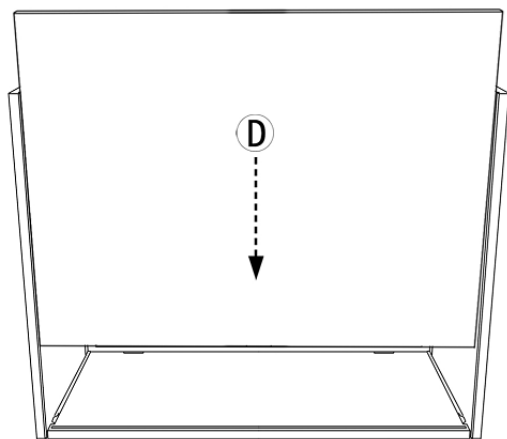

Step 3: Open the doors, attach the Tabletop (A) to the Body (B) with Hex bolts (H1) and Washers (H2) by Allen key (H5) as shown in picture below.

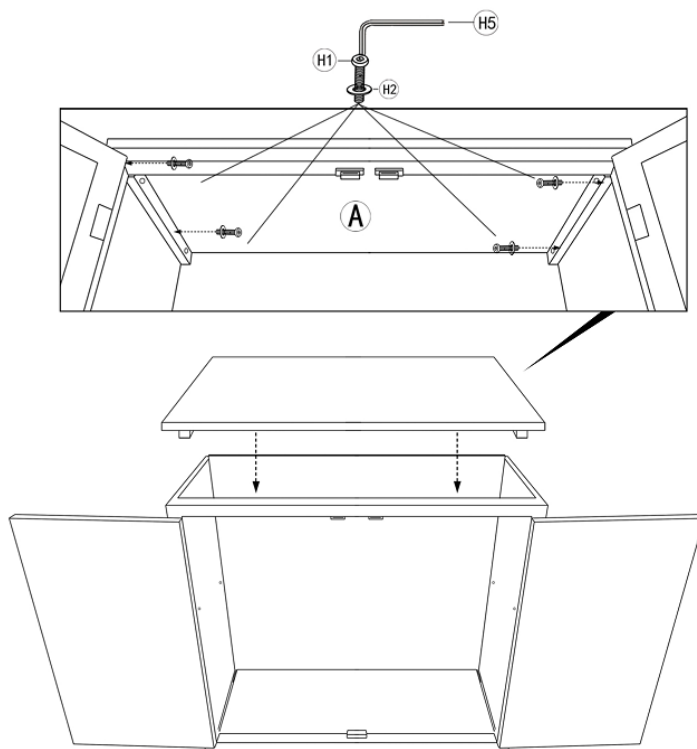

Step 4: Attached the Legs(E) to the bottom of the Body (B) with Hex bolts (H6&H7) by Allen key (H5) , and insert the Foot pads (H3) to the Legs (E)

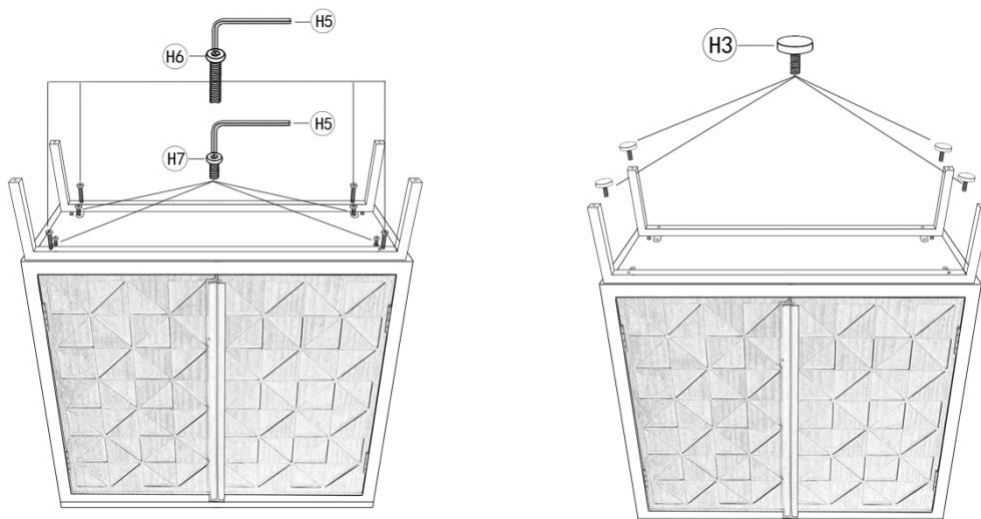

Step 5: Insert the metal pins (H4) on left&Right panel as below left photo shows. Place the Shelf (C) inside as shown in picture below.

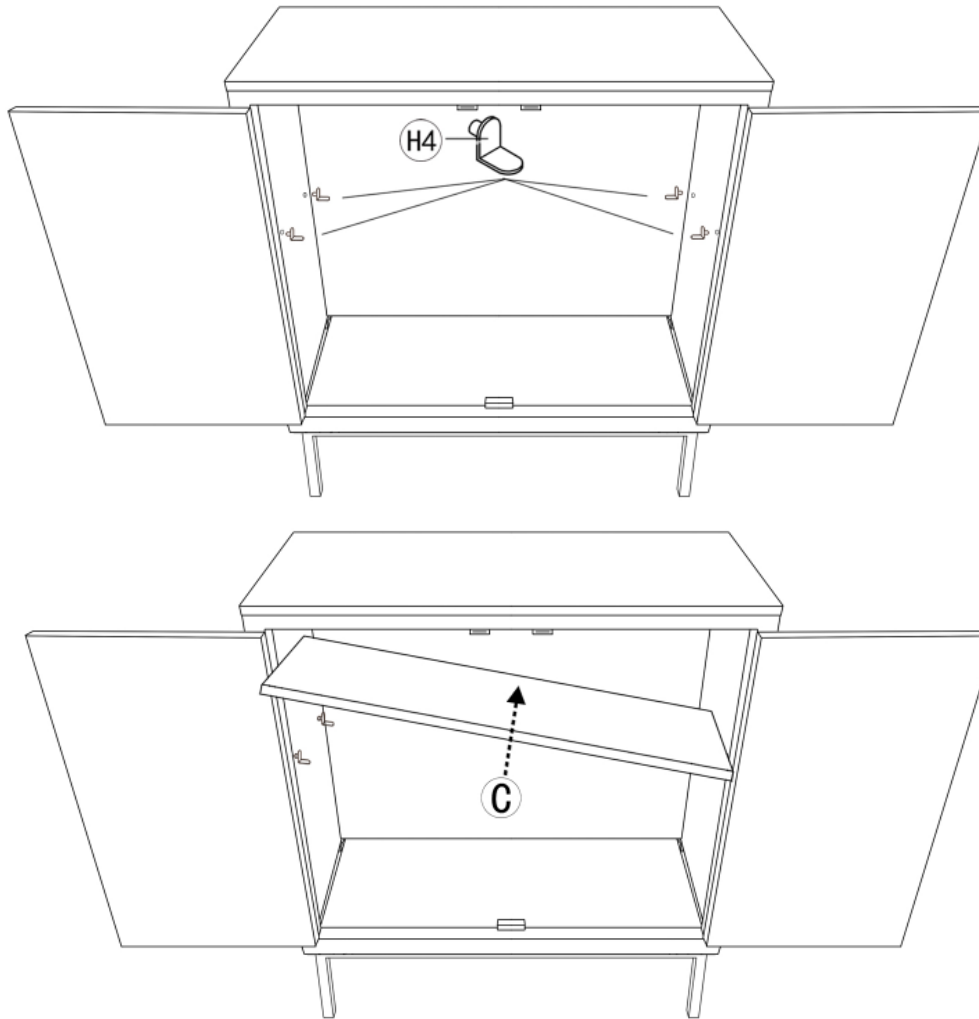

Assembly finished.

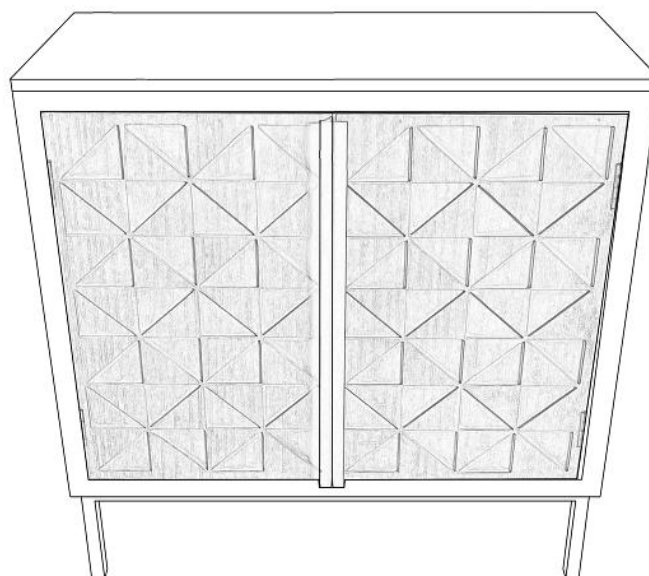

Notice:

If you have any questions about your purchase or any other product for sale, please contact Service@jimsidea.com with your order ID, our customer service representatives are available to help.