

ASSEMBLY INSTRUCTIONS

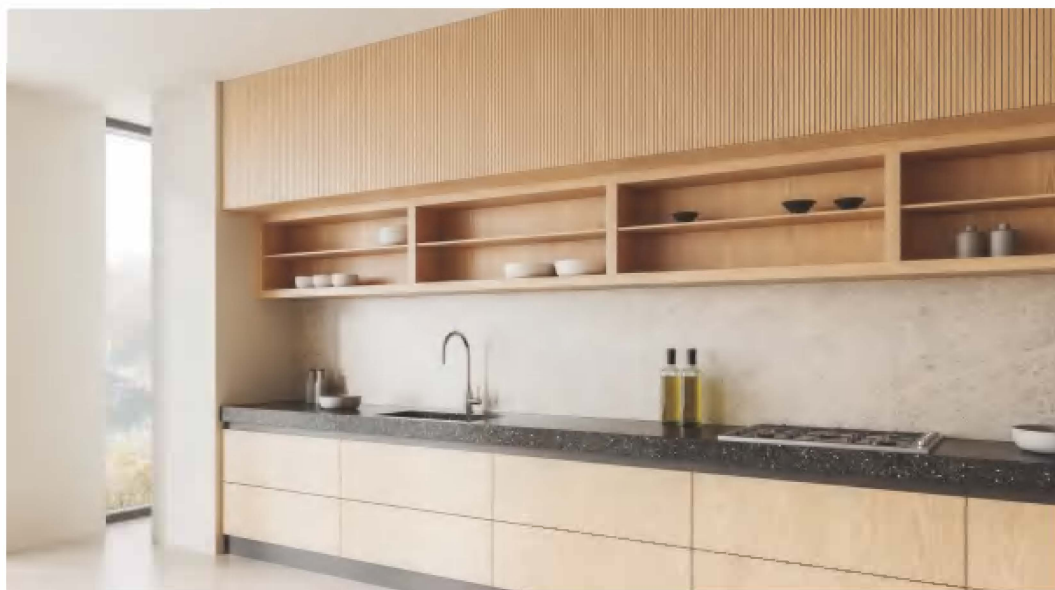

One of the unique features furniture is its versatility. Designed with the idea of customization in mind, our products can be easily linked together to create seamless, personalized setups that fit your specific needs.

For instance, if you purchase a couple of our shelves, you can effortlessly combine them to form a larger, unified structure. This modular approach allows you to expand, rearrange, and adapt your furniture as your space and style evolve. Whether you're looking to create a vast shelving system, or a continuous storage solution, the possibilities are endless.



Una de las características distintivas del mobiliario es su versatilidad. Diseñados pensando en la personalización, nuestros productos pueden conectarse fácilmente entre sí para crear configuraciones continuas y personalizadas que se ajusten a tus necesidades específicas.

Por ejemplo, si compras un par de nuestras estanterías, puedes combinarlas sin esfuerzo para formar una estructura más grande y unificada. Este enfoque modular te permite ampliar, reorganizar y adaptar tus muebles a medida que evolucionan tu espacio y tu estilo. Ya sea que busques crear un amplio sistema de estanterías o una solución de almacenamiento continua, las posibilidades son infinitas.

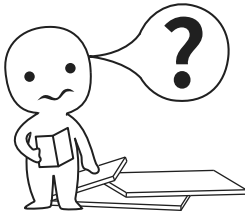

IMPORTANT INFORMATION!

Please read the entire manual before starting to assembling or using this product. Follow the manual thoroughly and keep it for further reference.

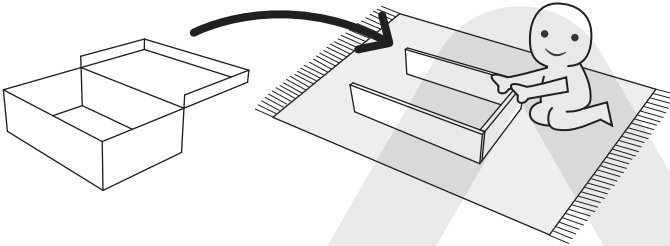

AVOID SCRATCHES!

In order to avoid scratching the furniture should be assembled on a soft layer—could be a rug.

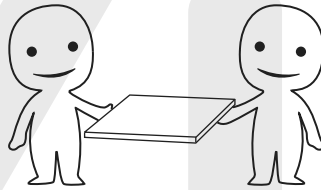

IMPROVE ASSEMBLY EFFICIENCY !

Try to find a partner to install with you, which can speed up the installation efficiency and shorten the time.

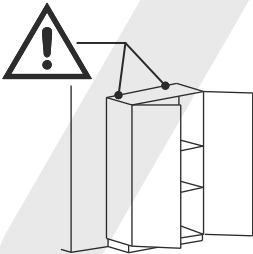

ANTI-TOPPLE WARNING !

Overtipped furniture can cause serious or fatal crush injuries. To prevent tipping, be sure to use a wall-anchoring attachment. If one is not included with this product, please purchase a suitable attachment that fits your wall. If unsure, seek professional advice. Please read and follow all instructions carefully.

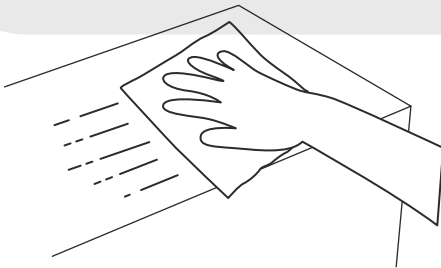

MAINTENANCE AND CLEANING !

For regular maintenance and cleaning, use a rag dipped in neutral detergent to wipe the frame thoroughly, and then dry it with a clean rag. For glass surfaces, wipe with a rag dampened with water or glass cleaner, and then dry with a clean, dry cloth.

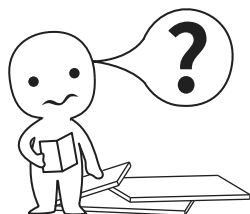

¡INFORMACIÓN IMPORTANTE!

Por favor, lee todo el manual antes de comenzar a ensamblar o usar este producto. Sigue las instrucciones detenidamente y consérvalo para futuras consultas.

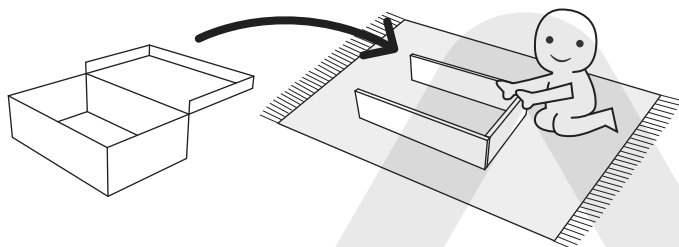

¡EVITA LOS RAYONES!

Para evitar que el mueble se raye, debe ensamblarse sobre una superficie suave, como una alfombra.

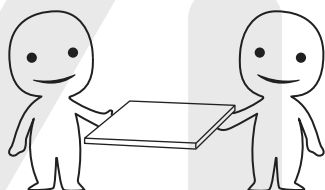

¡MEJORA LA EFICIENCIA!

Intenta encontrar a alguien que te ayude con la instalación; trabajar en pareja puede aumentar la eficiencia y reducir el tiempo de montaje.

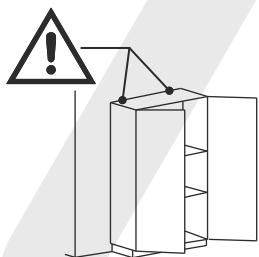

¡ADVERTENCIA ANTIVUELCO!

El mobiliario volcado puede causar lesiones graves o incluso mortales por aplastamiento. Para evitar que se vuelque, asegúrate de utilizar el sistema de anclaje a la pared. Si este producto no lo incluye, adquiere un anclaje compatible con tu pared. Si no estás seguro de cuál usar, busca asesoramiento profesional. Lee y sigue cuidadosamente cada paso de las instrucciones.

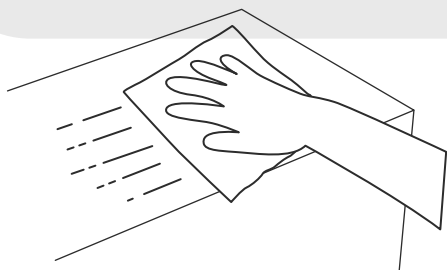

¡MANTENIMIENTO Y LIMPIEZA!

Para el mantenimiento y la limpieza regulares del producto, limpia el marco con un paño humedecido en un detergente neutro y luego sécalo con un paño limpio. Para los materiales de vidrio, límpialos con un paño humedecido en limpiador de vidrios con agua y luego sécalos con un paño seco.



The following are common installation steps. Correct operation is required to avoid product damage.

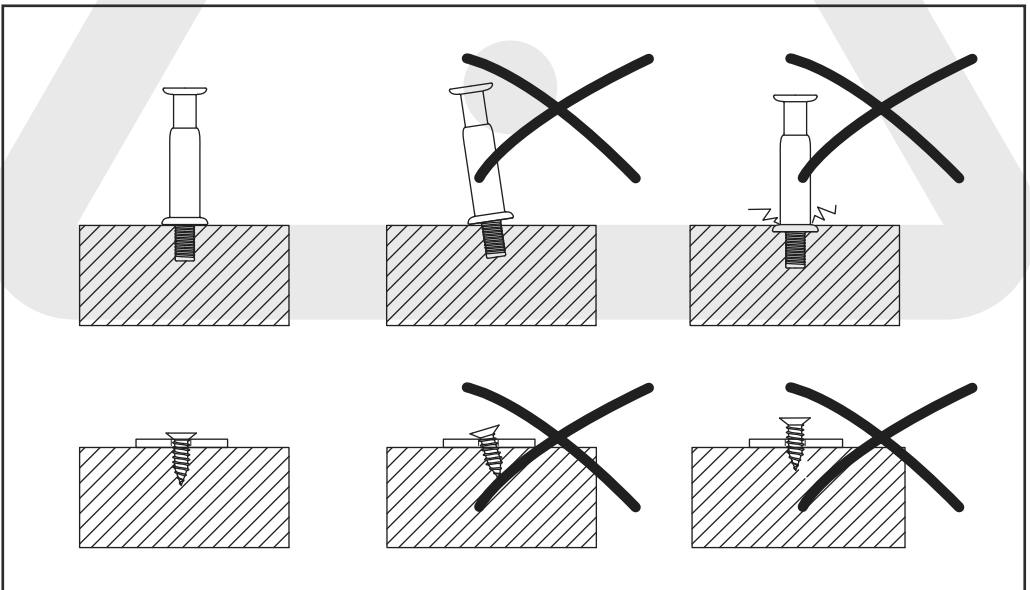
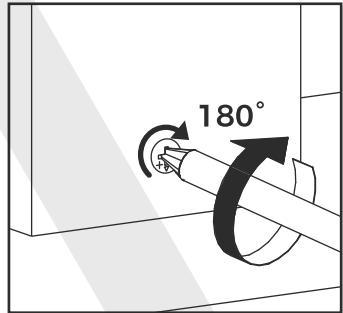
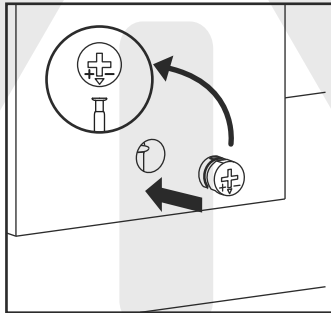
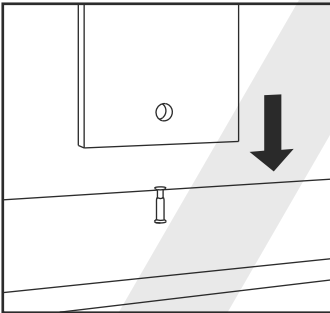
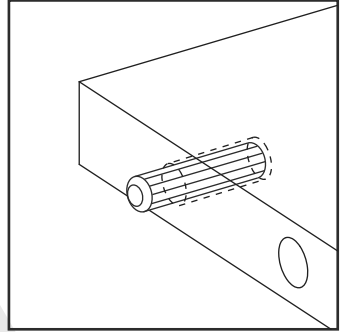
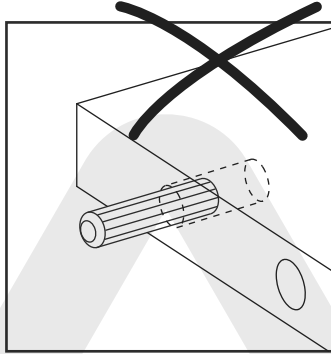
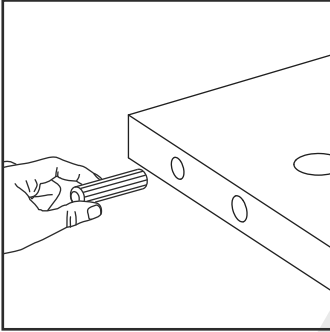



Los siguientes pasos de instalación son bastante comunes y requieren una operación correcta durante el proceso de montaje. El uso incorrecto puede dañar el mueble.

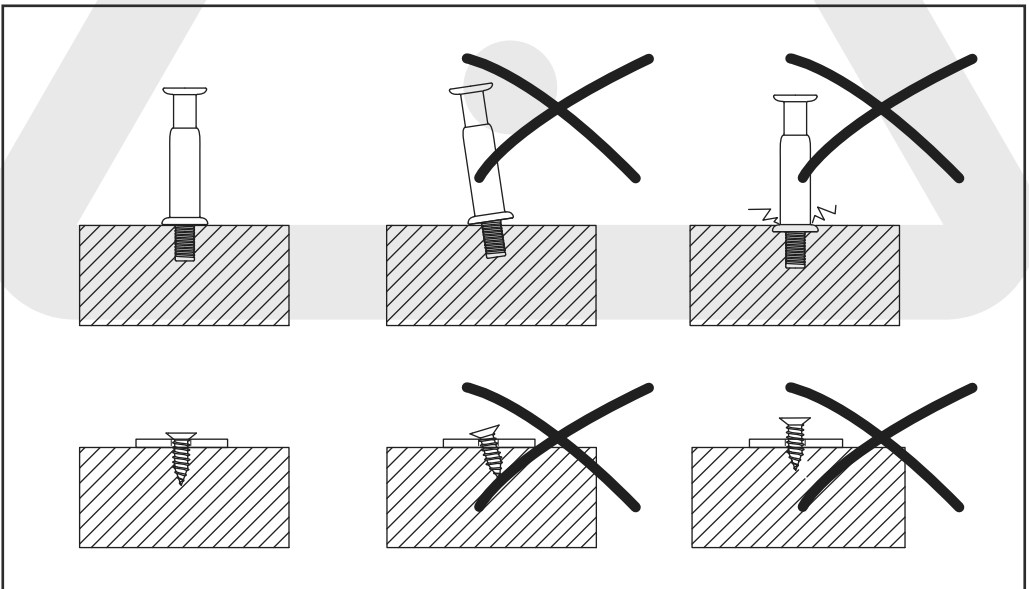
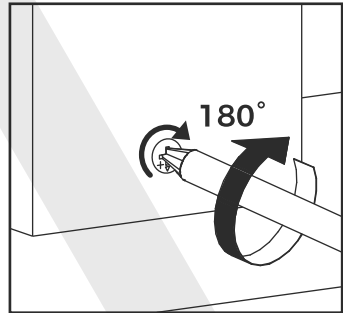
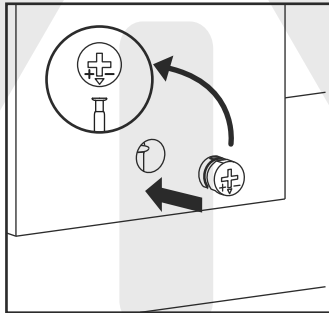
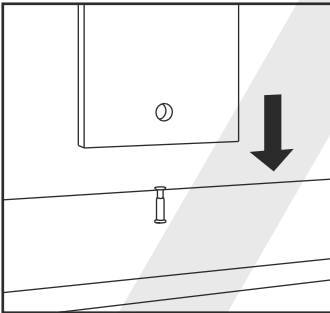
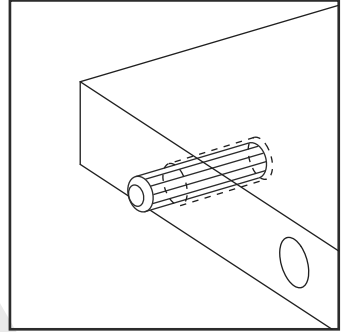
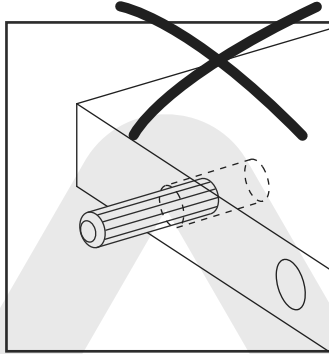
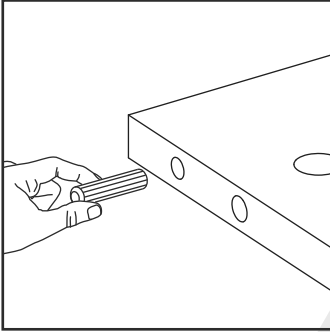



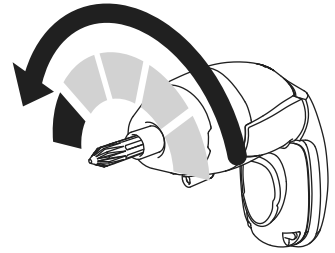
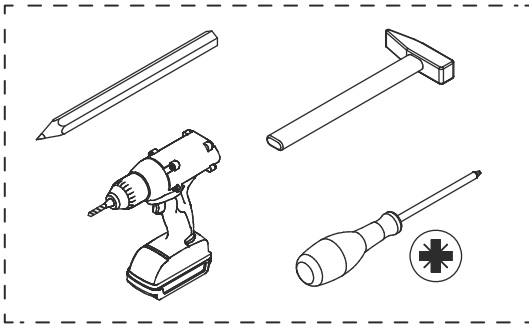





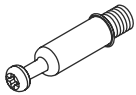

Please prepare the following tools

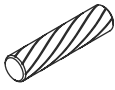
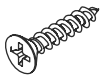

If you choose to use power tools, set them to a low-power setting. Use caution—power tools may crack or damage the furniture and can also harm the hardware.

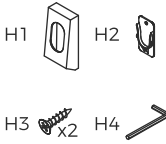
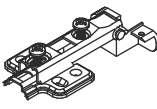
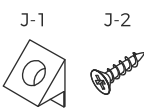

Some accessories have similar shapes, please distinguish them according to their numbers and sizes during installation.

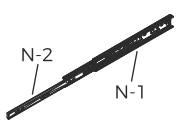
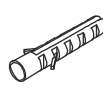
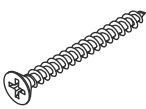
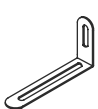
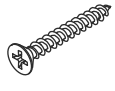
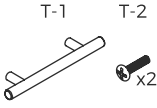
<p>A x 24</p>  <p>Ø6 x 35 mm</p>	<p>B x 24</p>  <p>Ø9.5 x 15 mm</p>	<p>C x 16</p>  <p>Ø8 x 30 mm</p>	<p>D x 6</p>  <p>Ø4 x 25 mm</p>	<p>E x 4</p>  <p>Ø6 x 20 mm</p>
<p>F x 2</p>  <p>Ø4 x 12 mm</p>	<p>G x 14</p>  <p>Ø3.5 x 12 mm</p>	<p>H x 2</p> 	<p>I x 10</p> 	<p>J x 6</p>  <p>Ø3 x 16 mm</p>
<p>K x 40</p>  <p>Ø3.5 x 14 mm</p>	<p>L x 20</p>  <p>Ø4 x 8 mm</p>	<p>M x 4</p>  <p>Ø3 x 12 mm</p>	<p>N x 2</p> 	<p>O x 2</p> 
<p>P x 2</p>  <p>Ø4 x 40 mm</p>	<p>Q x 2</p> 	<p>S x 5</p>  <p>Ø4 x 35 mm</p>	<p>T x 4</p> 	



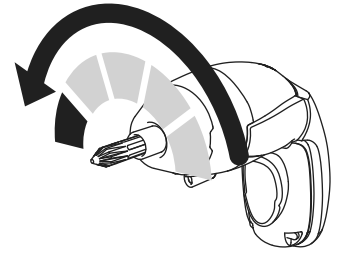
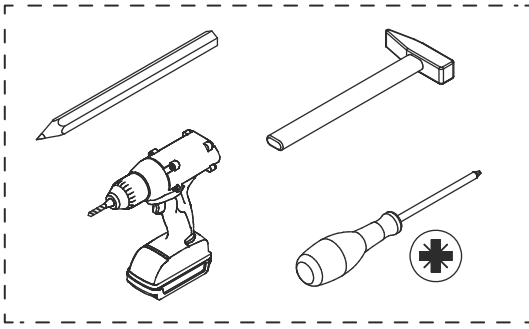







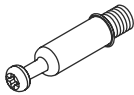

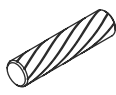
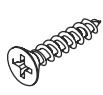
Por favor, prepara las siguientes herramientas

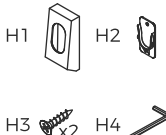
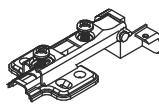
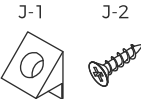

Si decides utilizar herramientas eléctricas, ajústalas a una velocidad baja. ¡Ten cuidado! Las herramientas eléctricas pueden causar grietas o daños en el mueble, y también pueden dañar los herrajes.

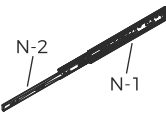
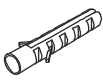
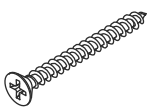

Algunos accesorios tienen la misma forma; por favor, distíngalos según sus números y tamaños durante la instalación.

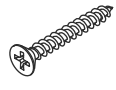
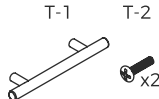
<p>A x 24</p>  <p>Ø6 x 35 mm</p>	<p>B x 24</p>  <p>Ø9.5 x 15 mm</p>	<p>C x 16</p>  <p>Ø8 x 30 mm</p>	<p>D x 6</p>  <p>Ø4 x 25 mm</p>	<p>E x 4</p>  <p>Ø6 x 20 mm</p>
<p>F x 2</p>  <p>Ø4 x 12 mm</p>	<p>G x 14</p>  <p>Ø3.5 x 12 mm</p>	<p>H x 2</p> 	<p>I x 10</p> 	<p>J x 6</p>  <p>Ø3 x 16 mm</p>
<p>K x 40</p>  <p>Ø3.5 x 14 mm</p>	<p>L x 20</p>  <p>Ø4 x 8 mm</p>	<p>M x 4</p>  <p>Ø3 x 12 mm</p>	<p>N x 2</p> 	<p>O x 2</p> 
<p>P x 2</p>  <p>Ø4 x 40 mm</p>	<p>Q x 2</p> 	<p>S x 5</p>  <p>Ø4 x 35 mm</p>	<p>T x 4</p> 	

Parts List

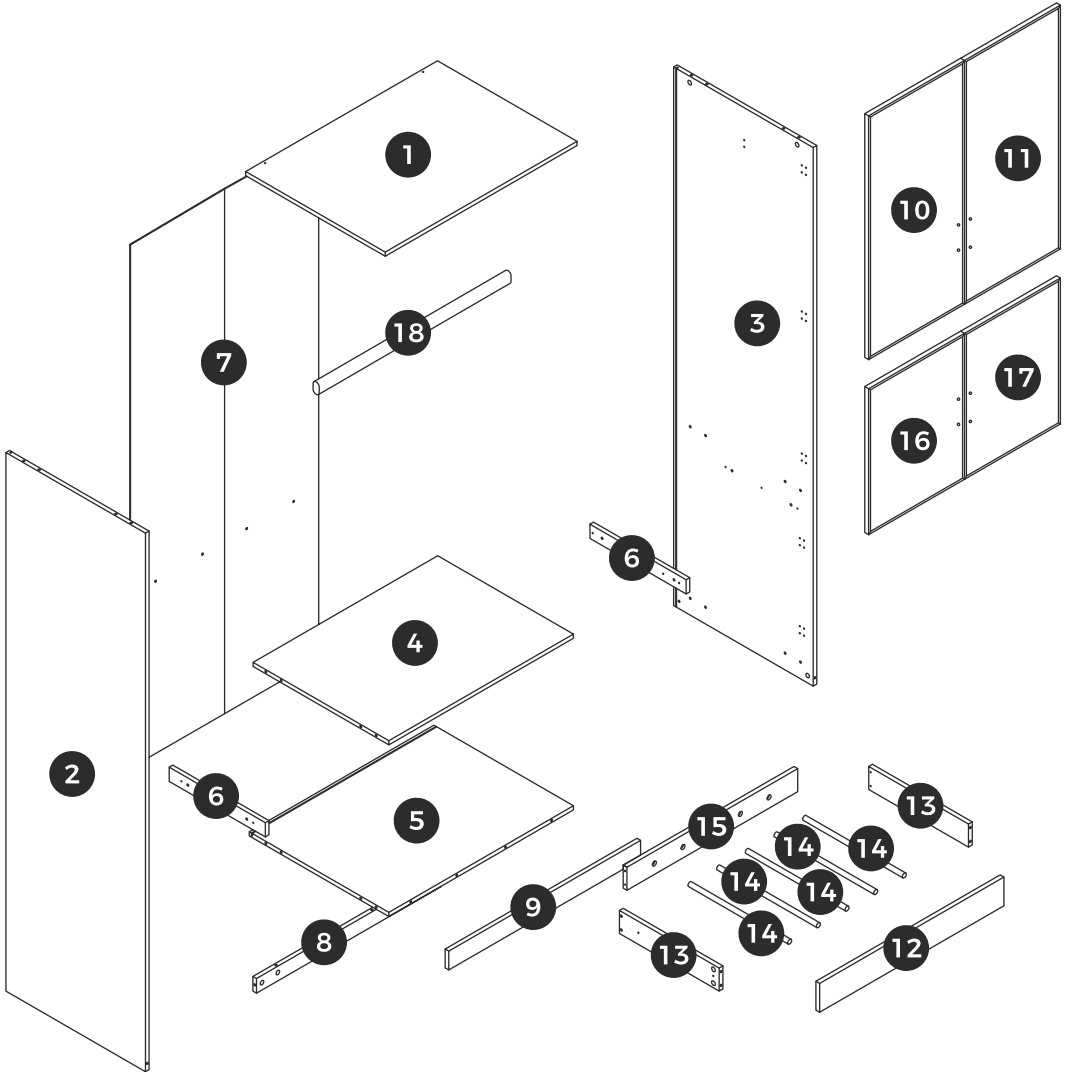

⚠ WARNING	
	<p>Children have died from furniture tipover. To reduce the risk of furniture tipover:</p> <ul style="list-style-type: none"> • ALWAYS install Anti-tip device provided • NEVER put a TV on this product. • NEVER allow children to stand, climb or hang on drawers, doors, or shelves. • NEVER open more than one drawer at a time. • Place heaviest items in the lowest drawers.
	<p>This is a permanent label. Do not remove!</p>



60 MINUTES



2 ADULTS



EASY

The parts listed above are required for proper assembly. If there are any issues.

Lista de Piezas

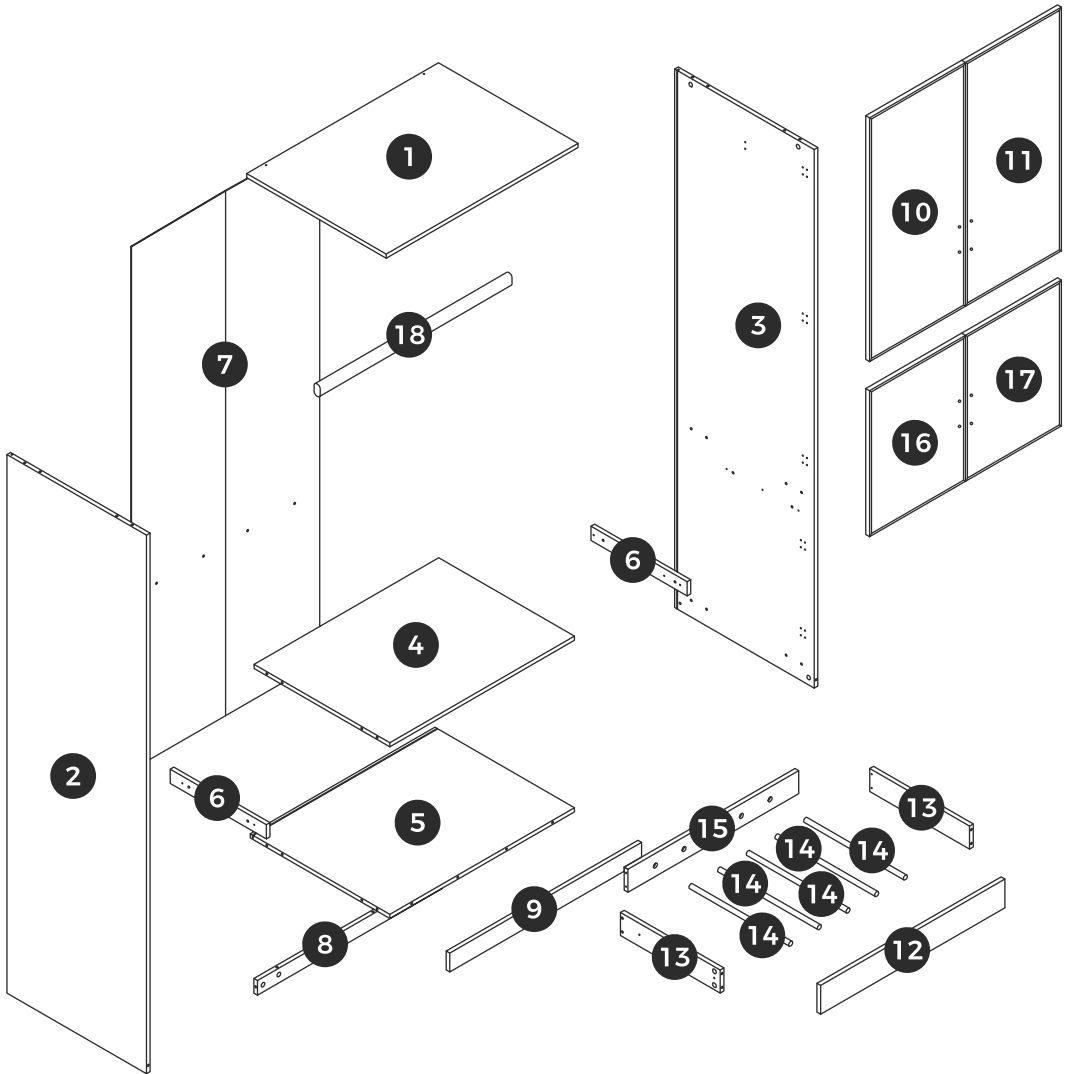

⚠ ADVERTENCIA



Los niños han muerto por el vuelco de muebles. Para reducir el riesgo de que el mueble se vuelque:

- SIEMPRE instala el dispositivo antivuelco incluido.
- NUNCA coloques un televisor sobre este producto.
- NUNCA permitas que los niños se suban, trepen o cuelguen de los cajones, puertas o estantes.
- NUNCA abras más de un cajón a la vez.
- Coloca los objetos más pesados en los cajones inferiores.

Esta es una etiqueta permanente.
¡No la retires!



60 MINUTOS



2 ADULTOS



FÁCIL

Las piezas enumeradas arriba son necesarias para un montaje correcto. Si tienes algún problema,

01



[EN] Separate the glide into two parts first.

[ES] Separe la guía en dos partes primero.

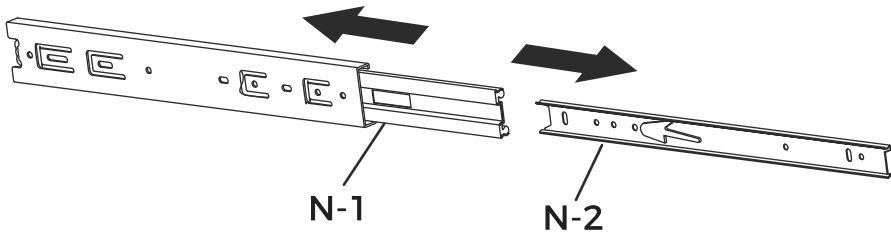
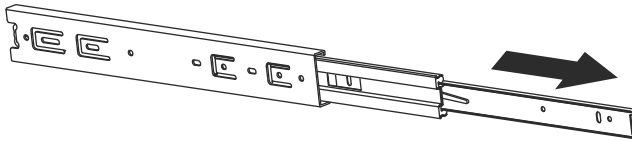
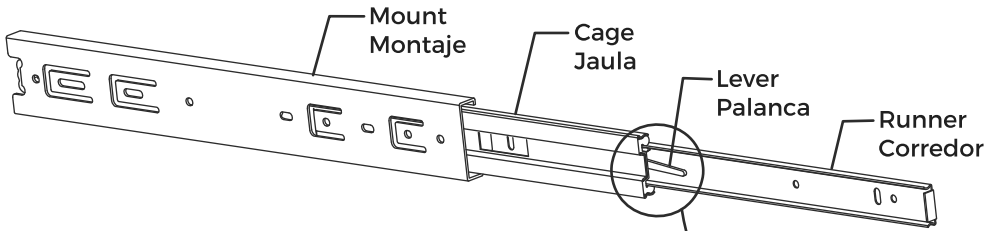

02

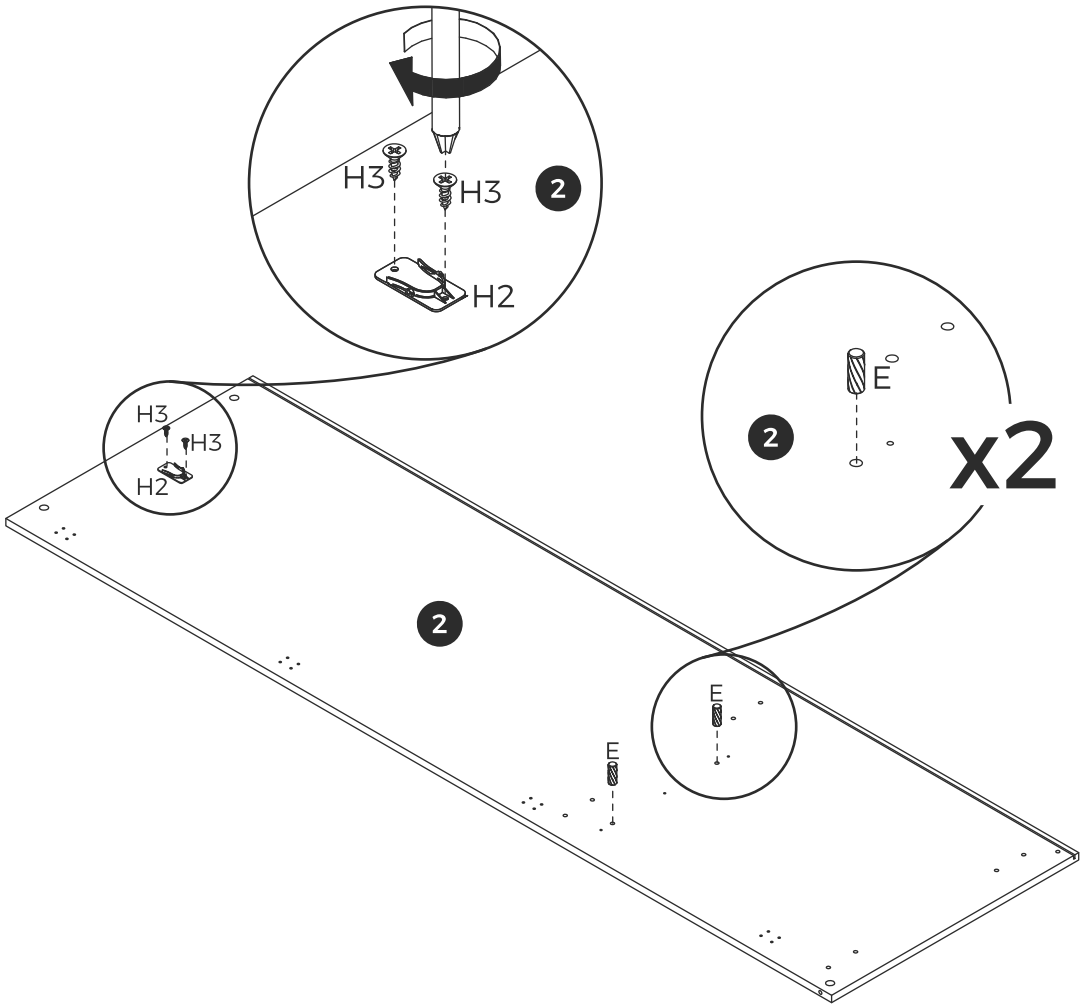

03

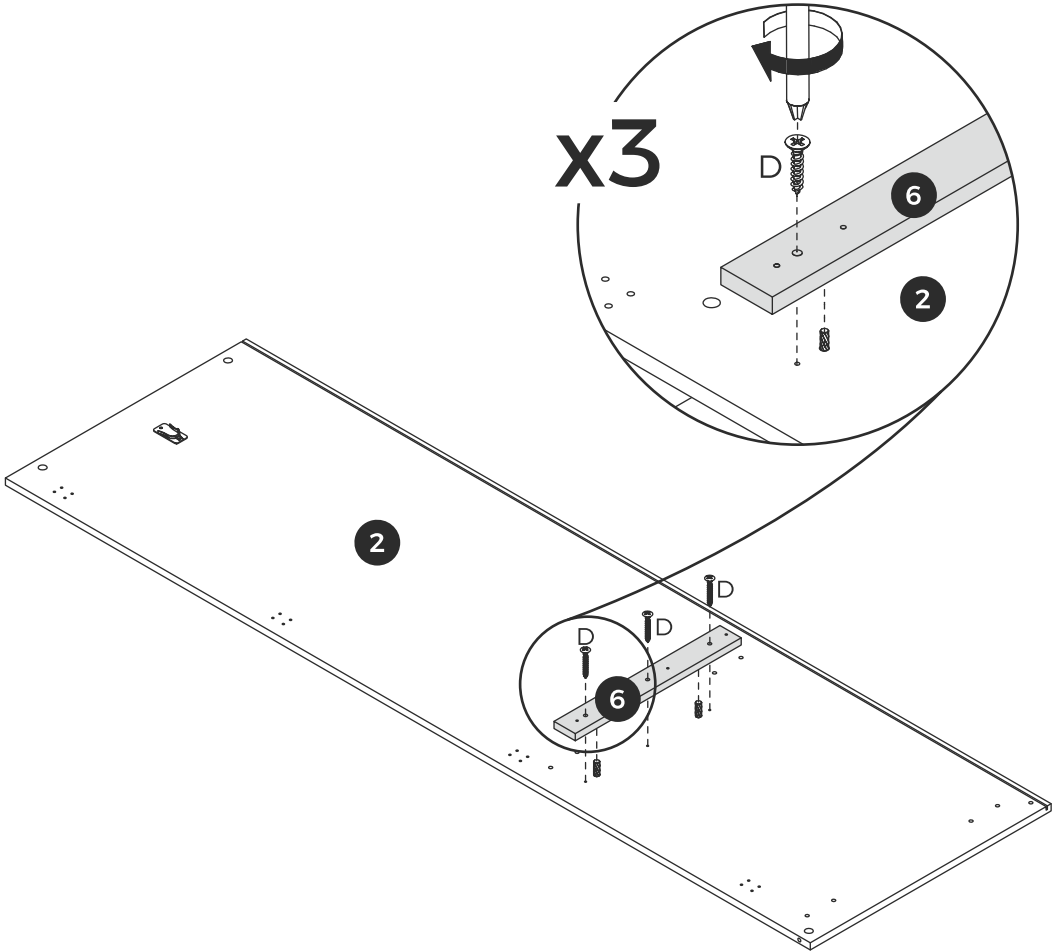

04

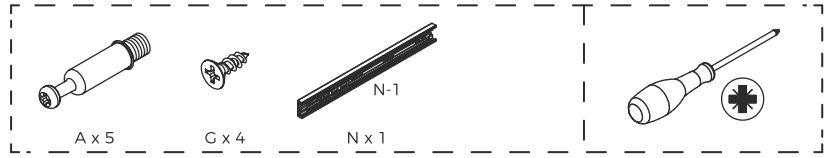

[EN] Insert eccentric rod A into board 2 and fix rail N-1 to board 6 with screw G.

[ES] Inserte la varilla excéntrica A en la tabla 2 y fije el riel N-1 a la tabla 6 con el tornillo G.

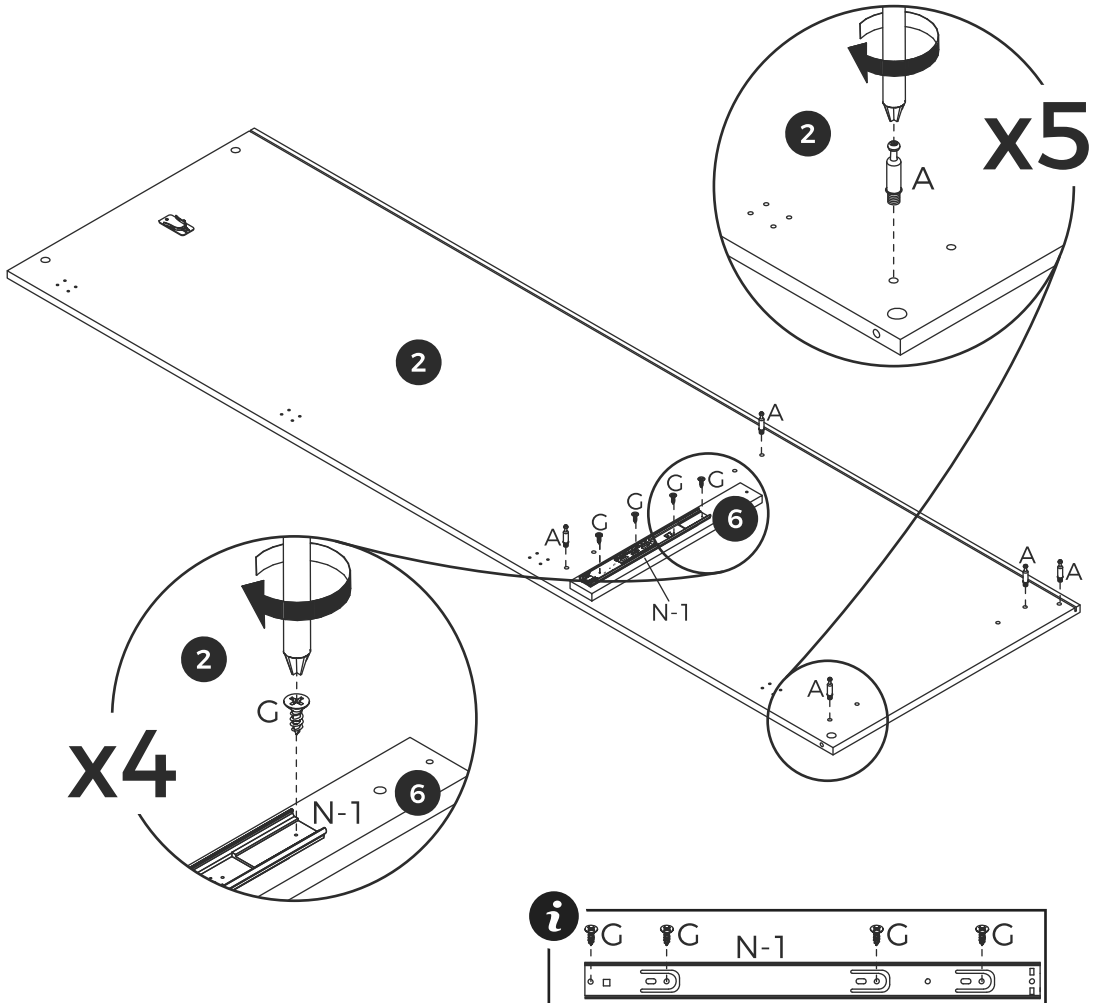

05

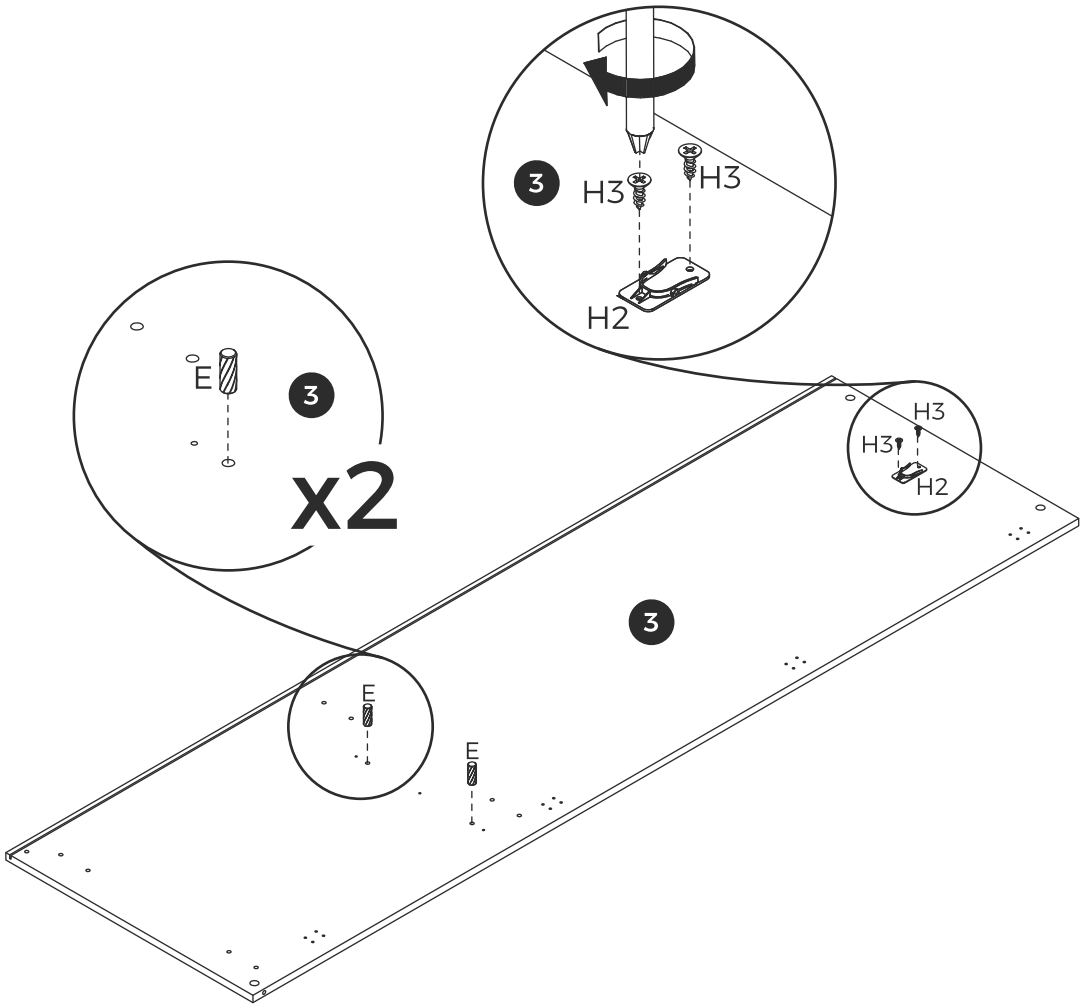

06

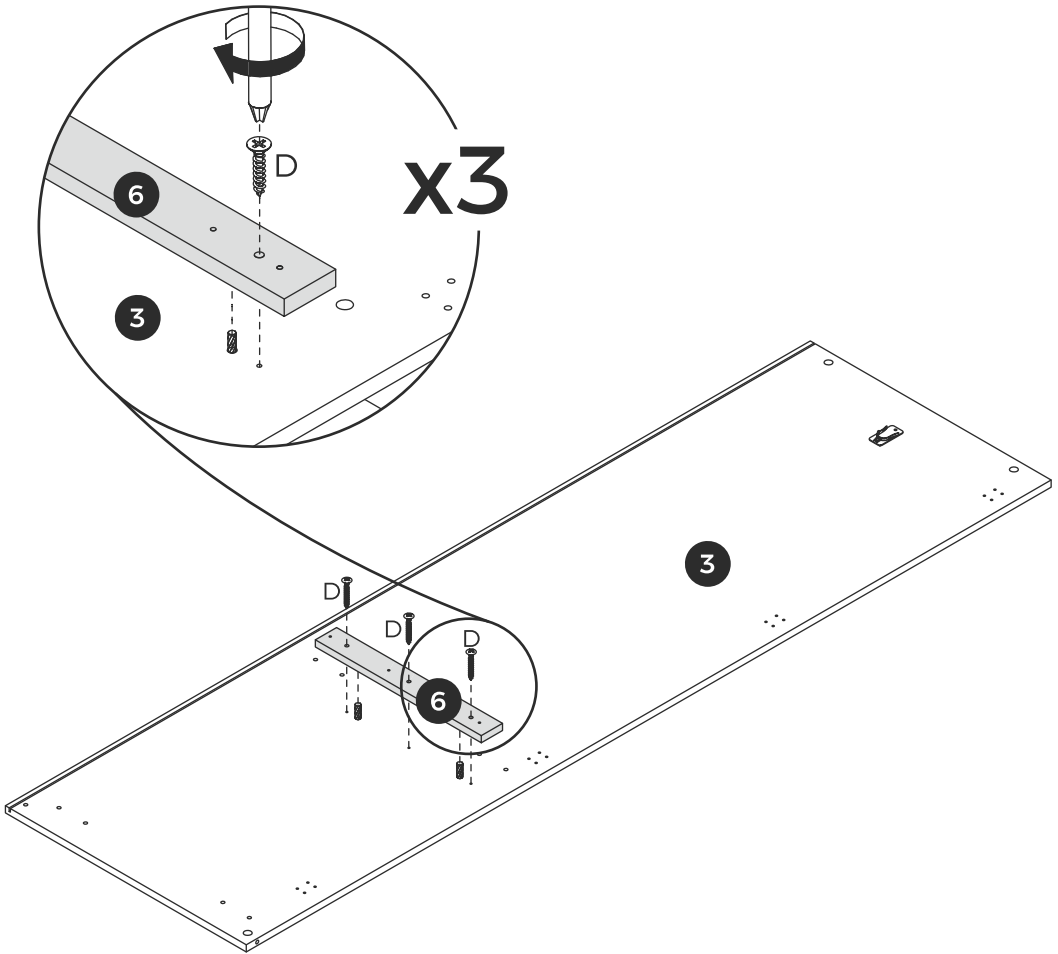

07

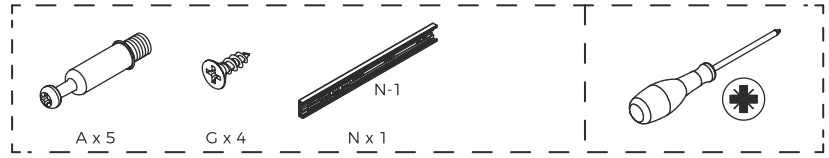

[EN] Insert eccentric rod A into board 3 and fix rail N-1 to board 6 with screw G.

[ES] Inserte la varilla excéntrica A en la tabla 3 y fije el riel N-1 a la tabla 6 con el tornillo G.

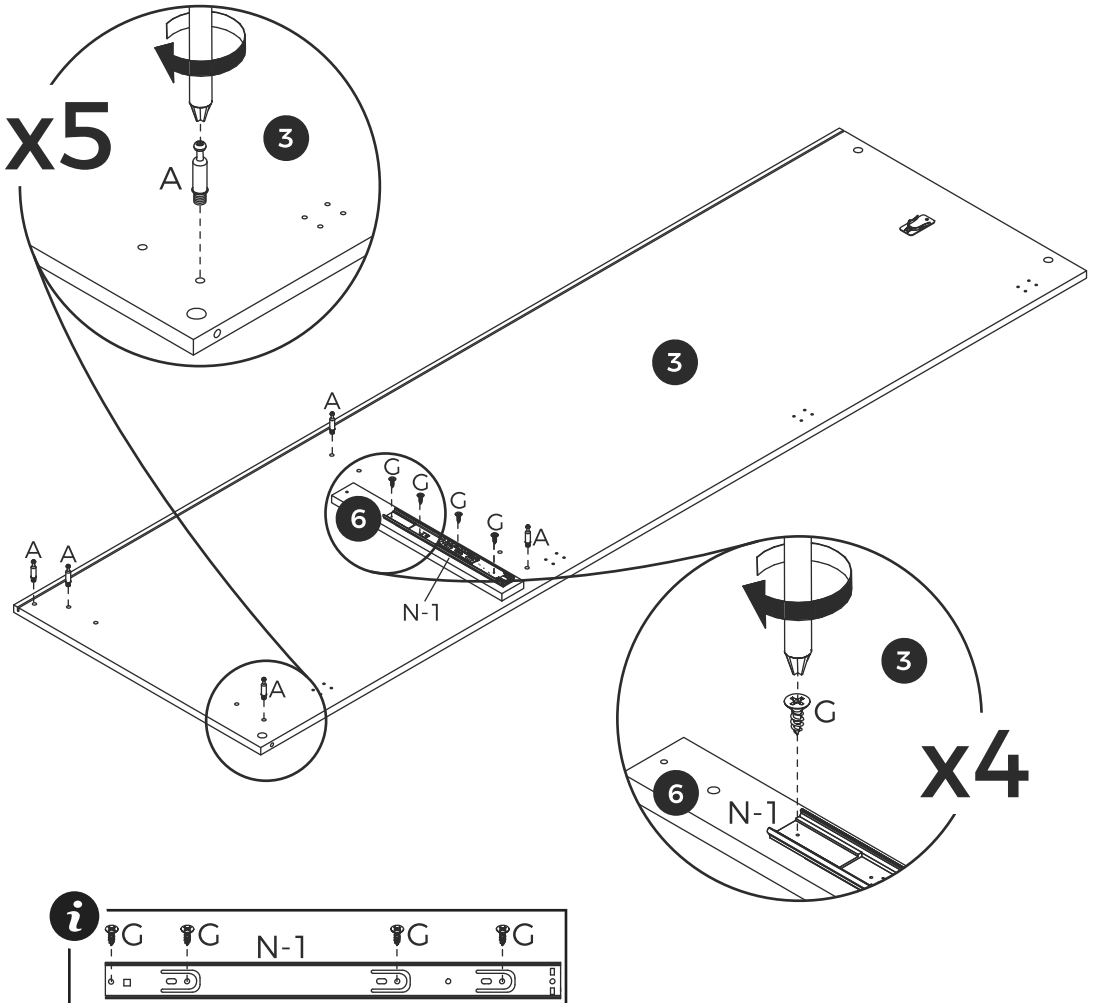

08

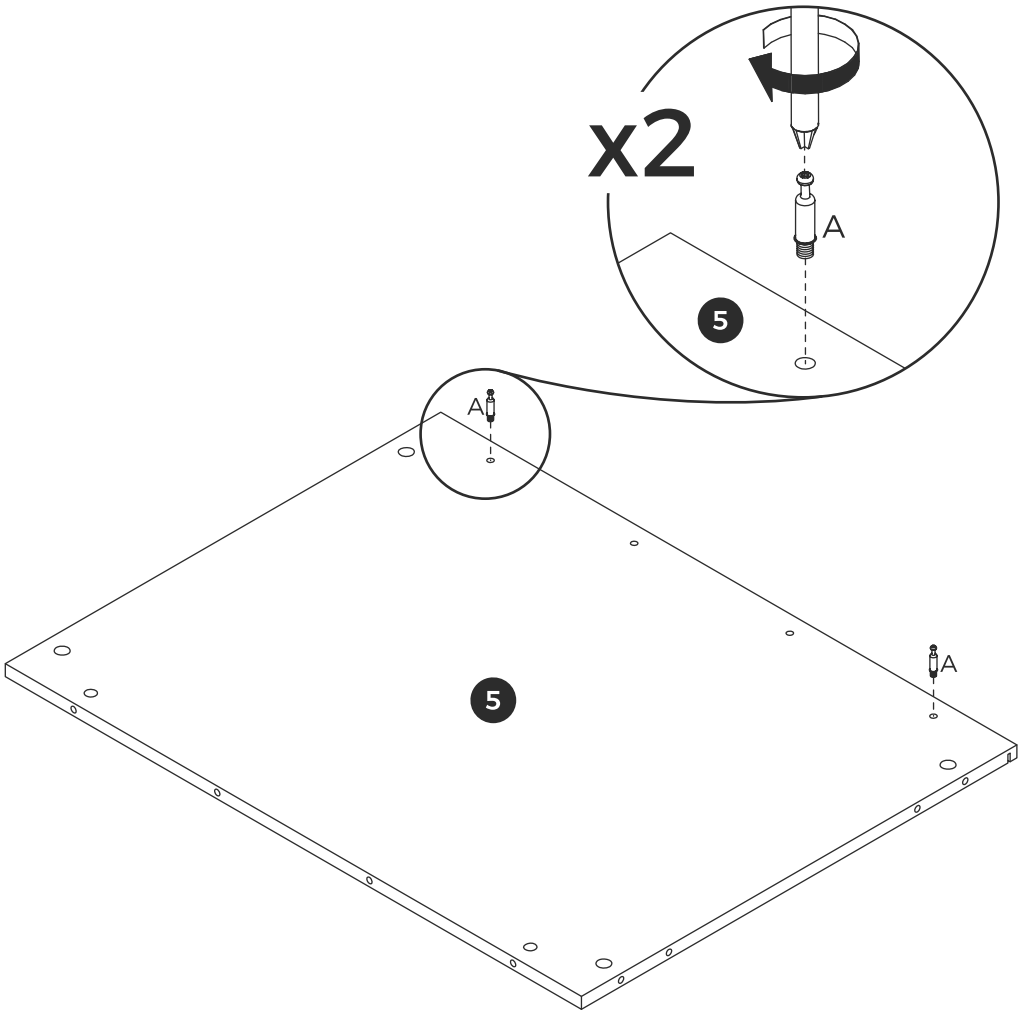

09

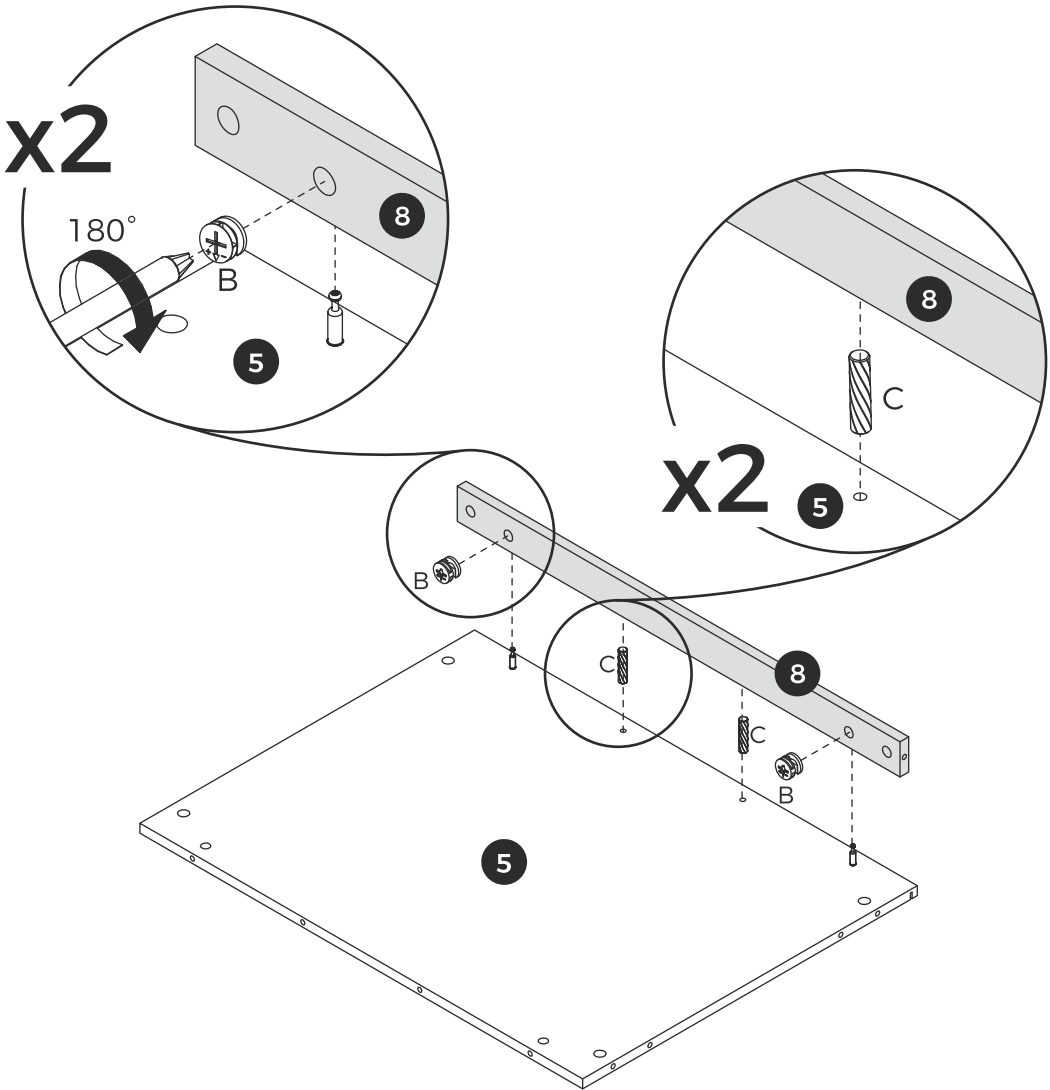

10

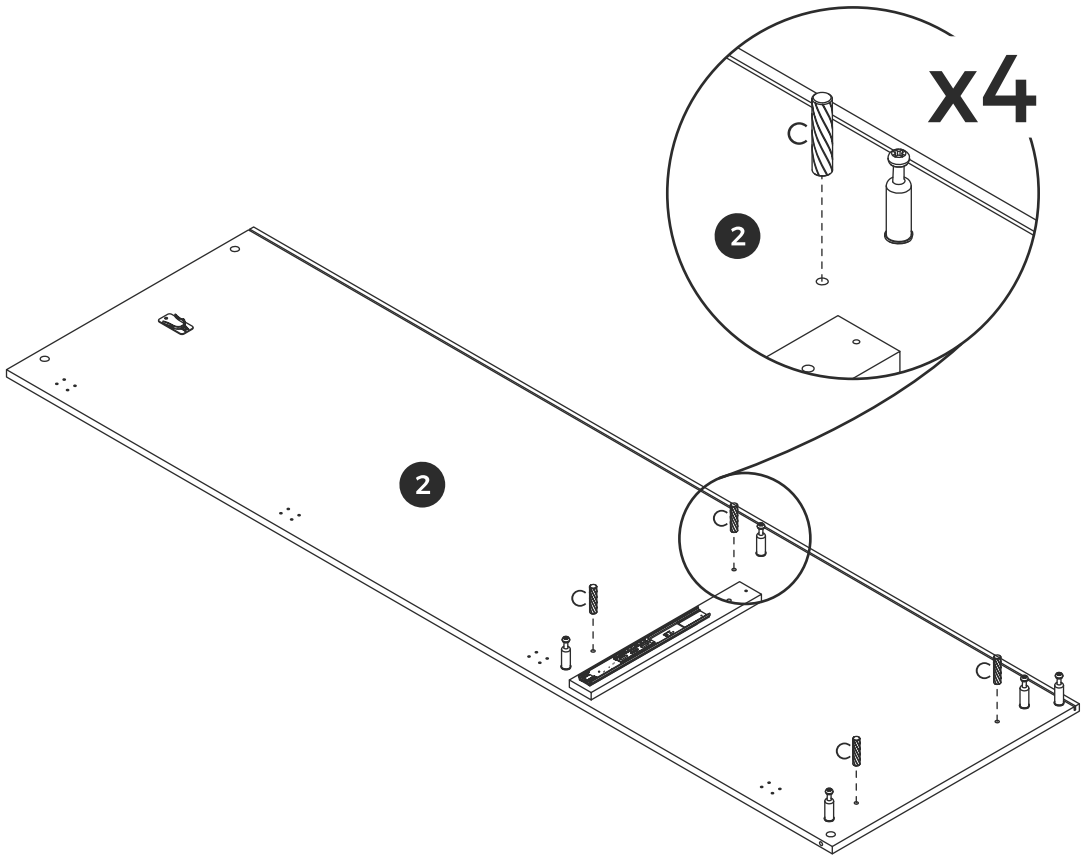

13



B x 5

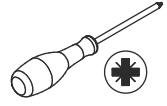

2 ADULTS

x5

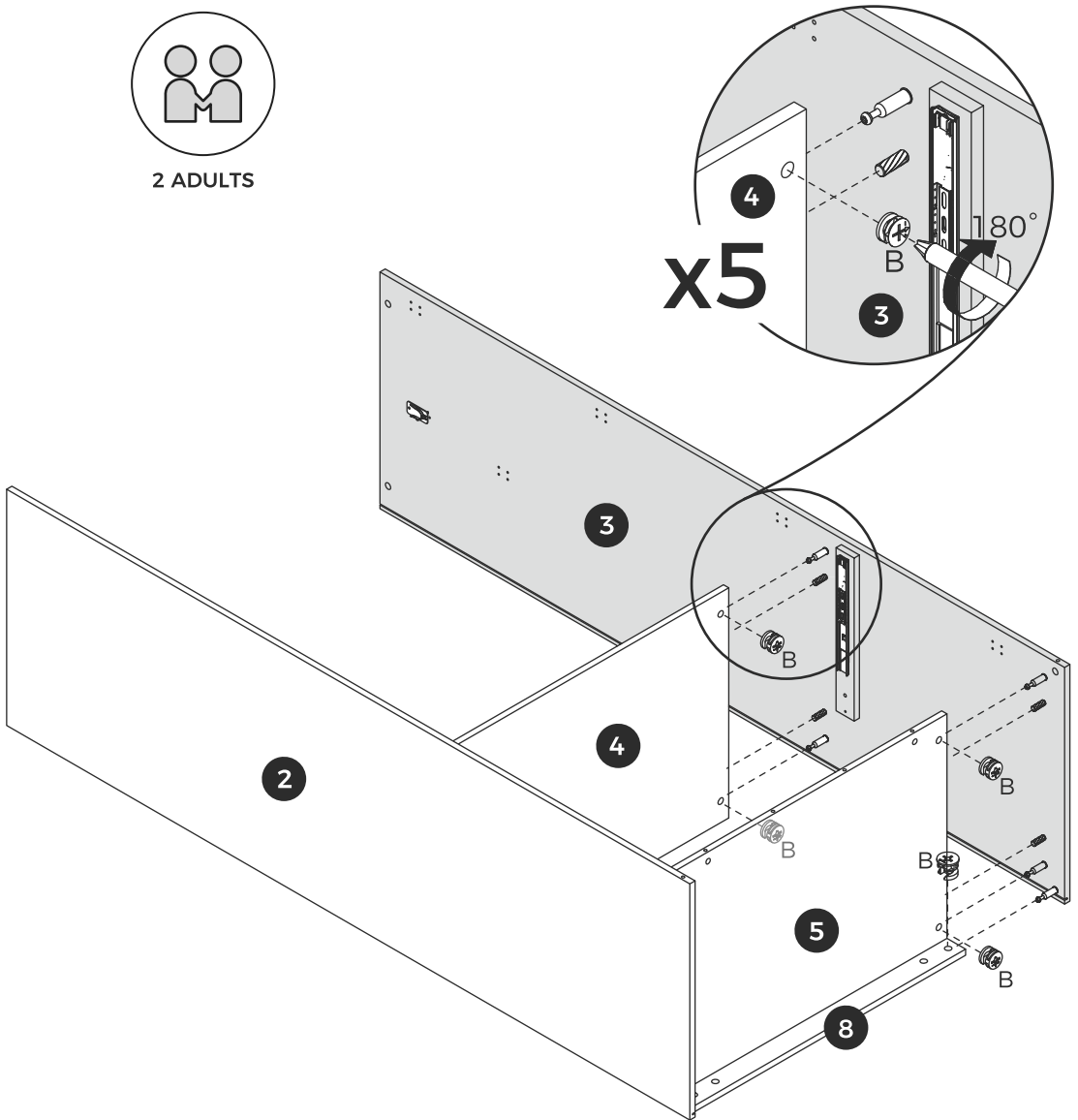

14

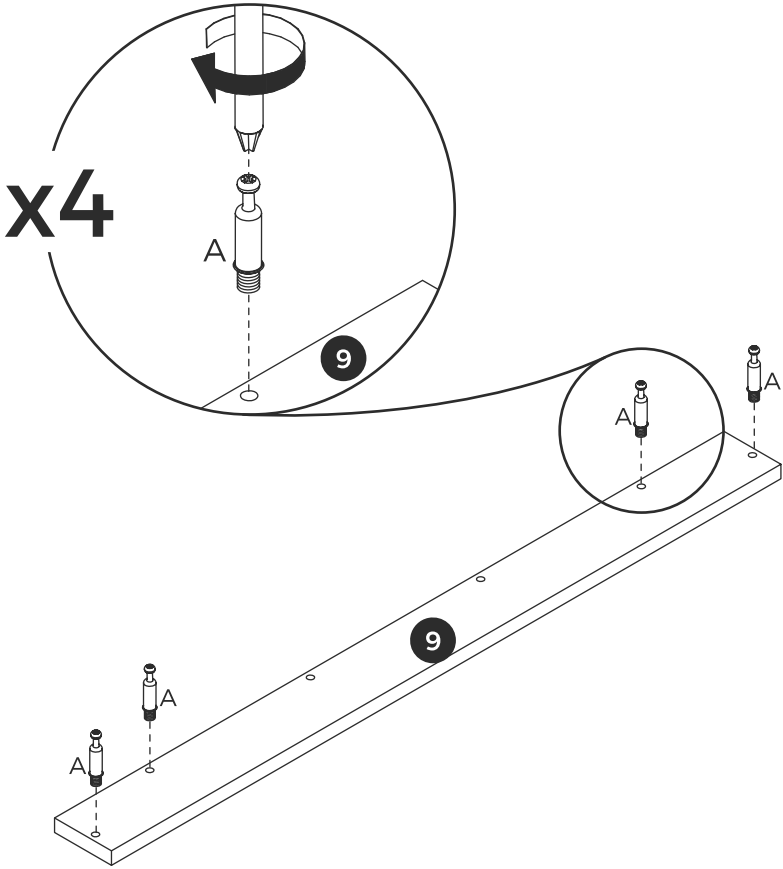

16

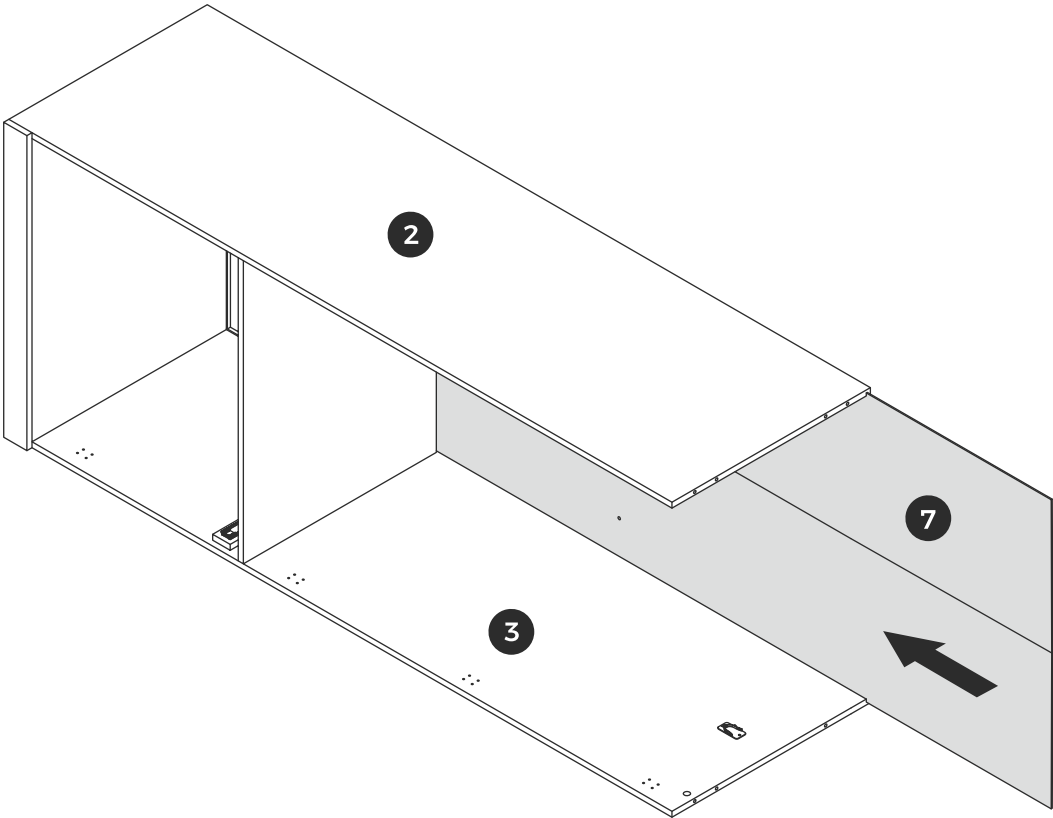

18

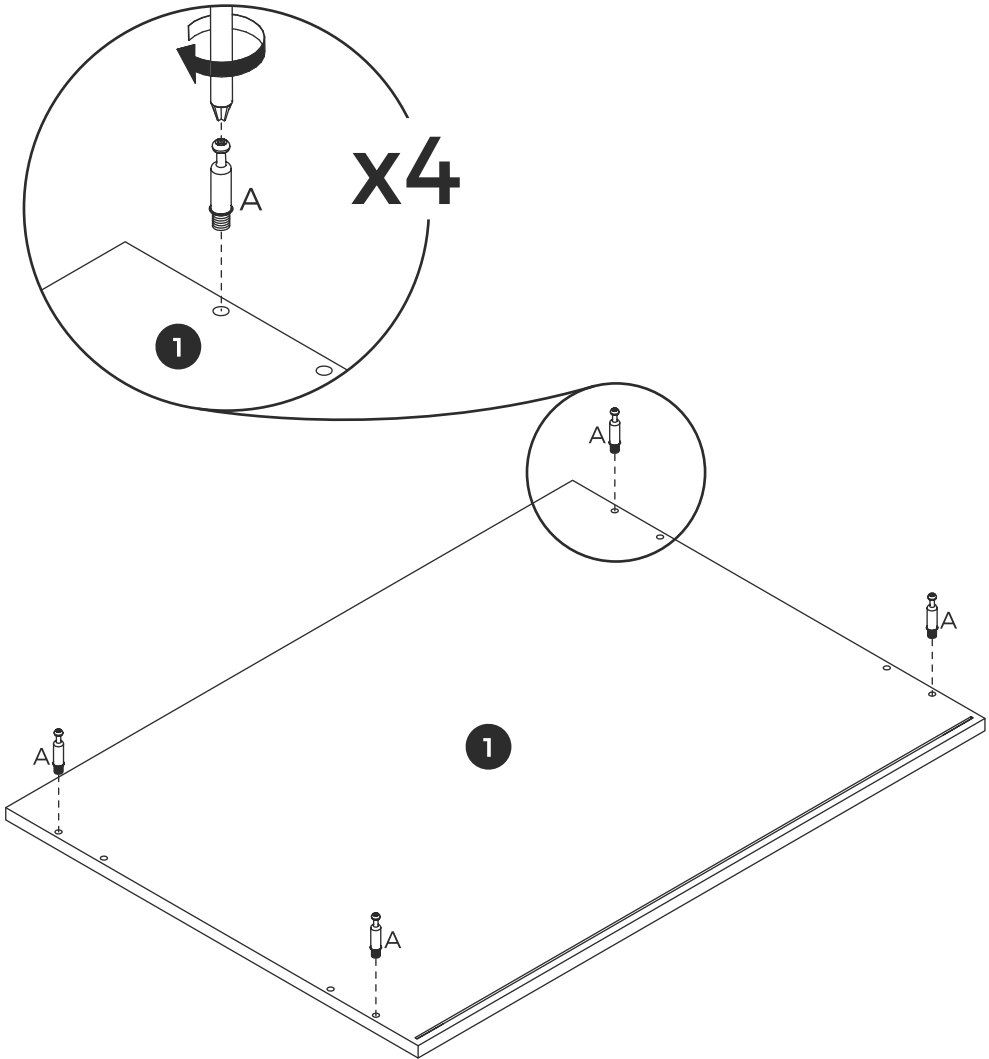

19

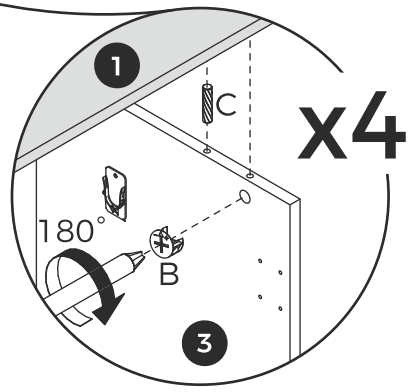
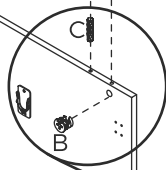
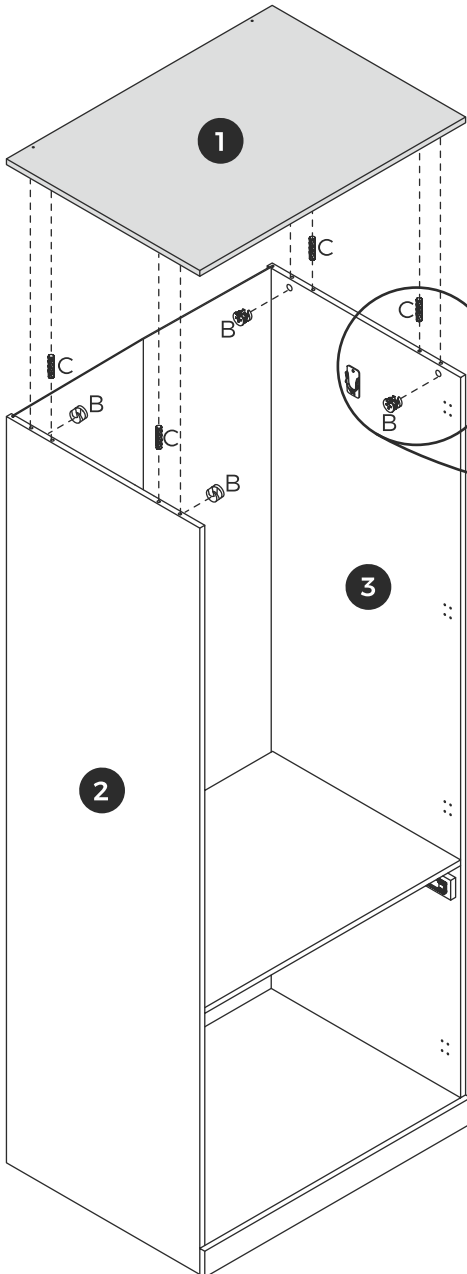

2 ADULTS

20

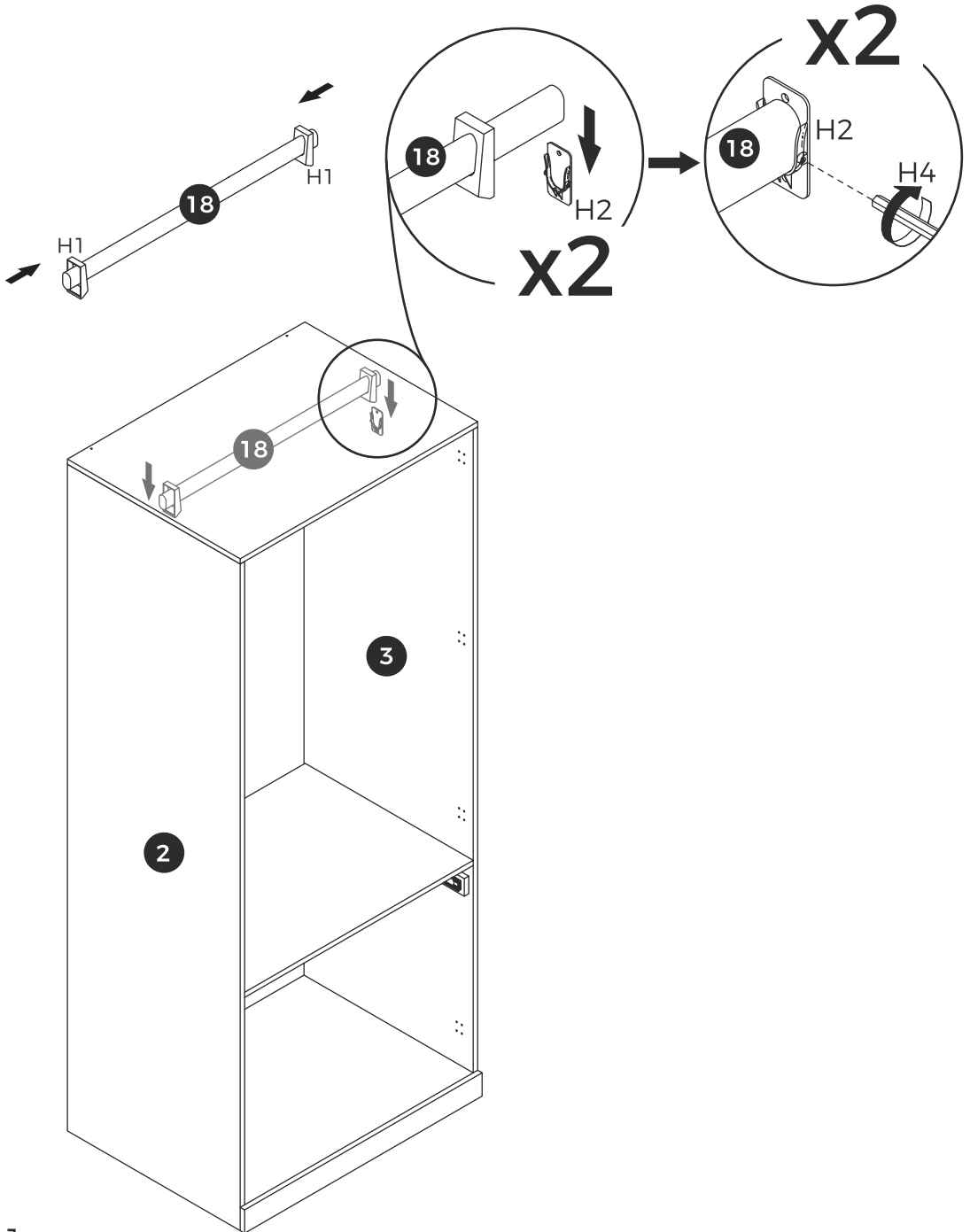

21

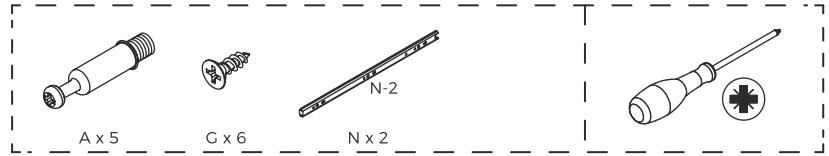

[EN] Insert eccentric rod A into board 12. Secure rail N-2 to boards 13 with screw G.

[ES] Inserte la varilla excéntrica A en la tabla 12. Fije el riel N-2 a las tablas 13 con el tornillo G.

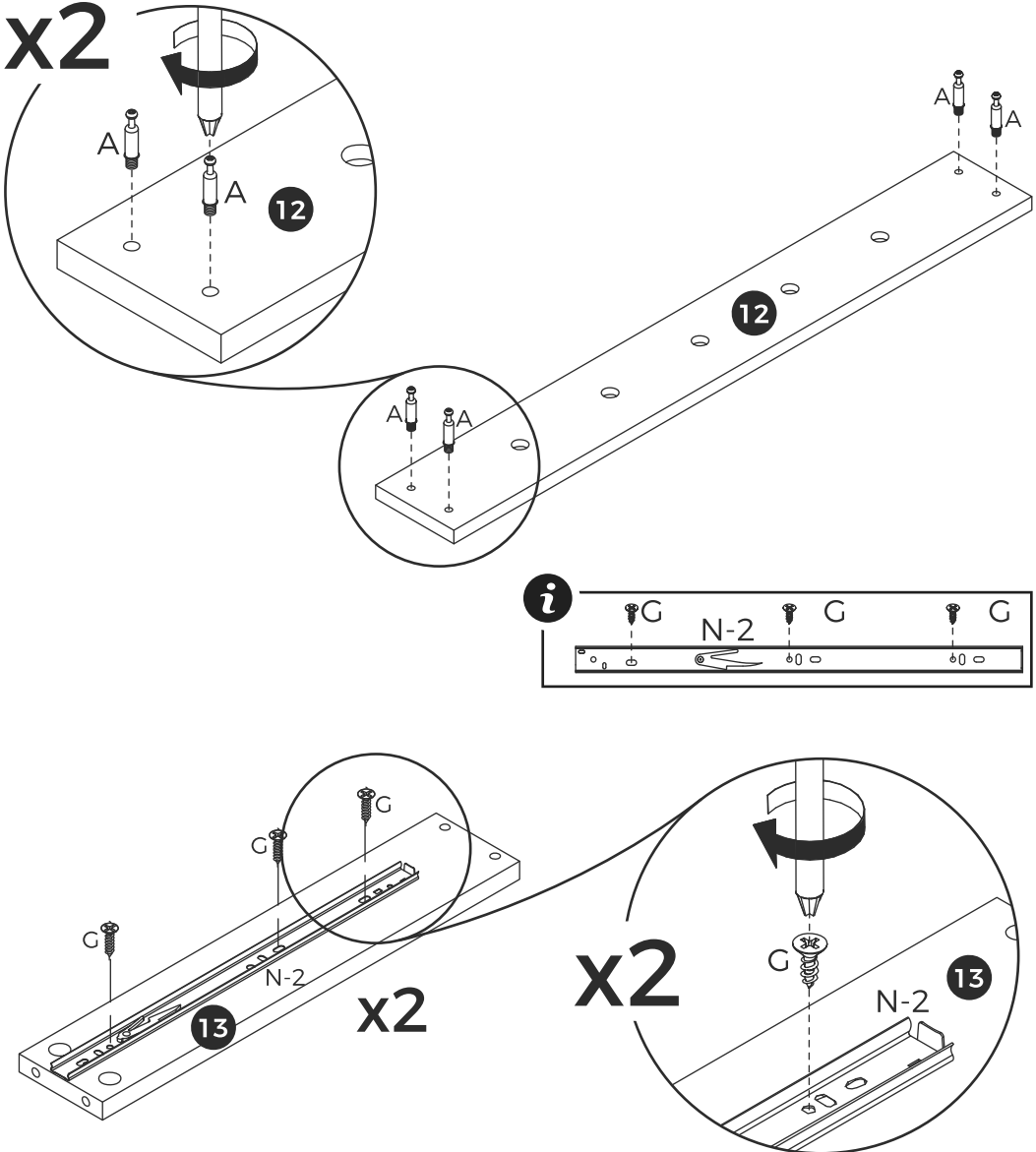

22



B x 4

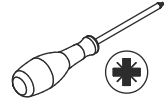

[EN] Connect boards 13,14 to board 12 and tighten by rotating eccentric cam B clockwise.

[ES] Conecte las placas 13,14 a la placa 12 y apriete girando la leva excéntrica B en el sentido de las agujas del reloj.

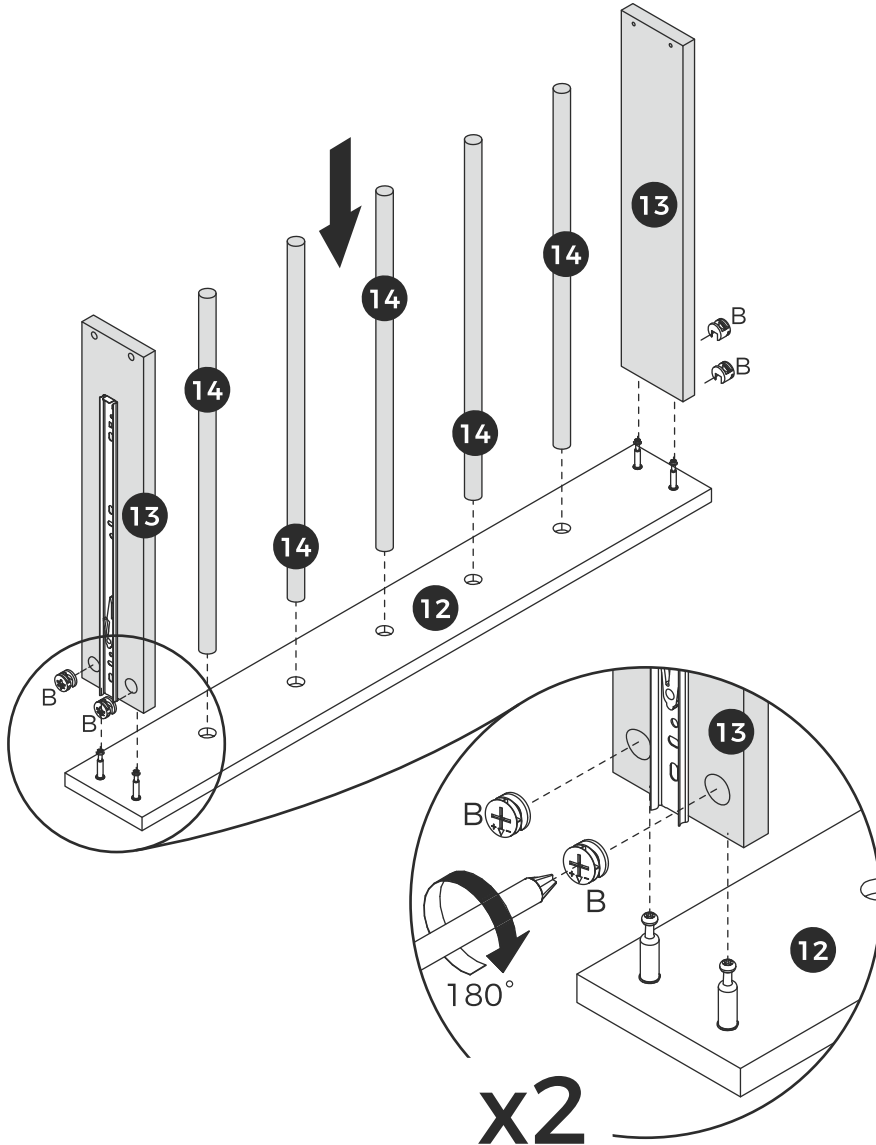

24

[EN] Pull out the drawer slide on the unit and align it with the drawer slide on the drawer, then gently push the drawer in to prevent the steel balls in the slide from falling out.

[ES] Extraiga la corredera del mueble y alinéela con la corredera del cajón, y luego empuje suavemente el cajón hacia adentro para evitar que las bolas de acero de la corredera se salgan.

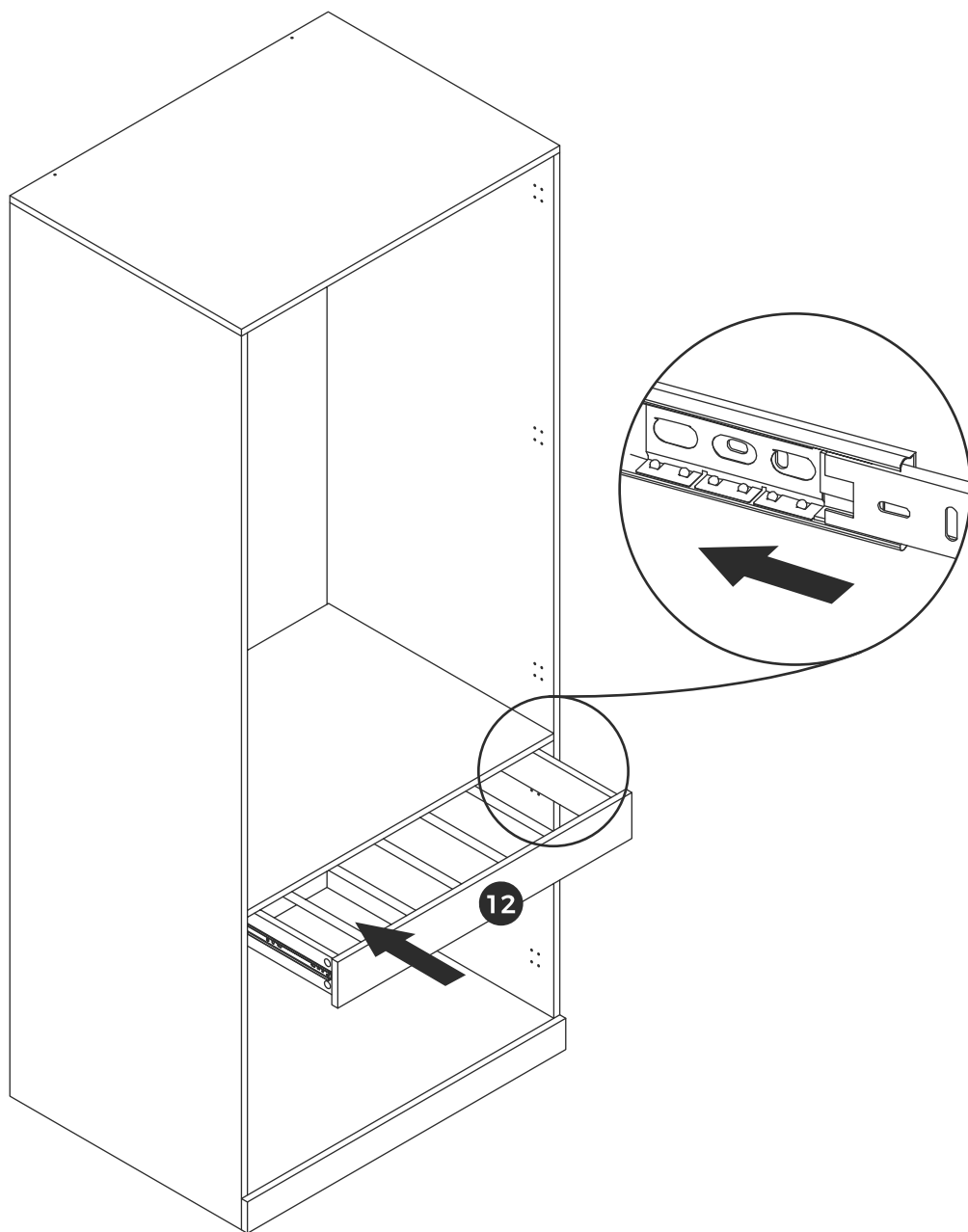

25



[EN] Secure hinge I to boards 10,11,16 and 17 with screw L.

[ES] Fije la bisagra I a las tablas 10,11,16 y 17 con el tornillo L.

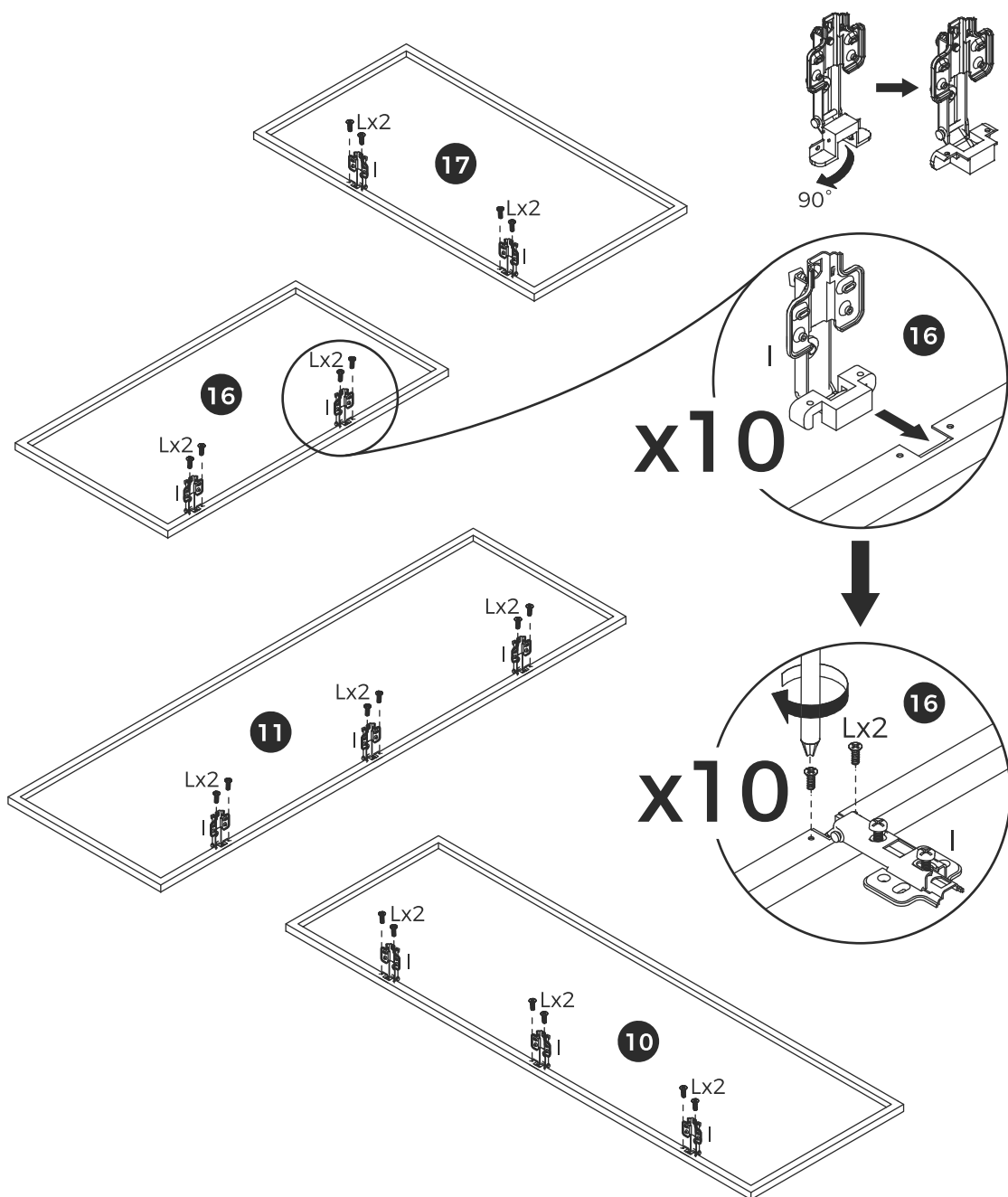

24

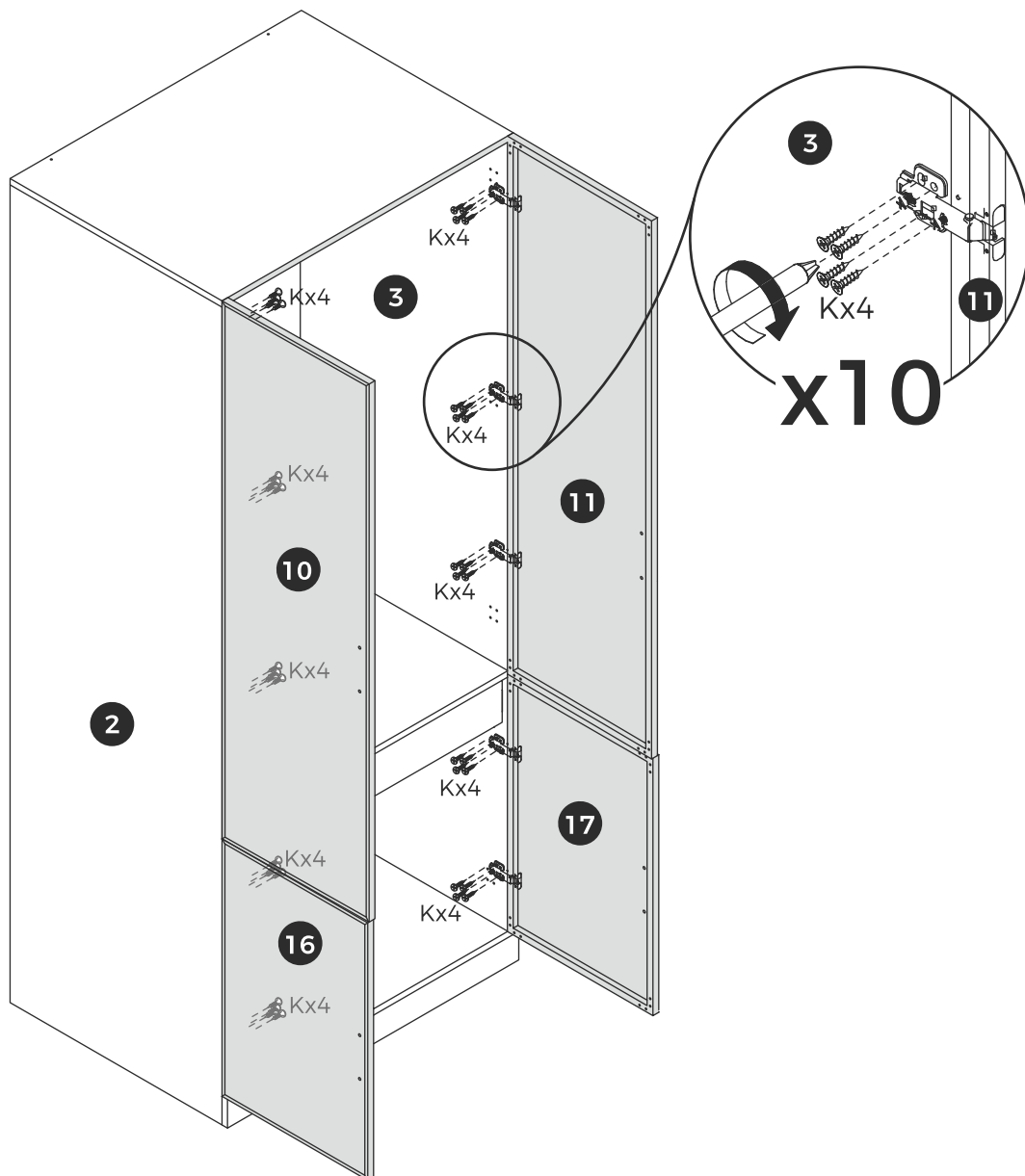

25

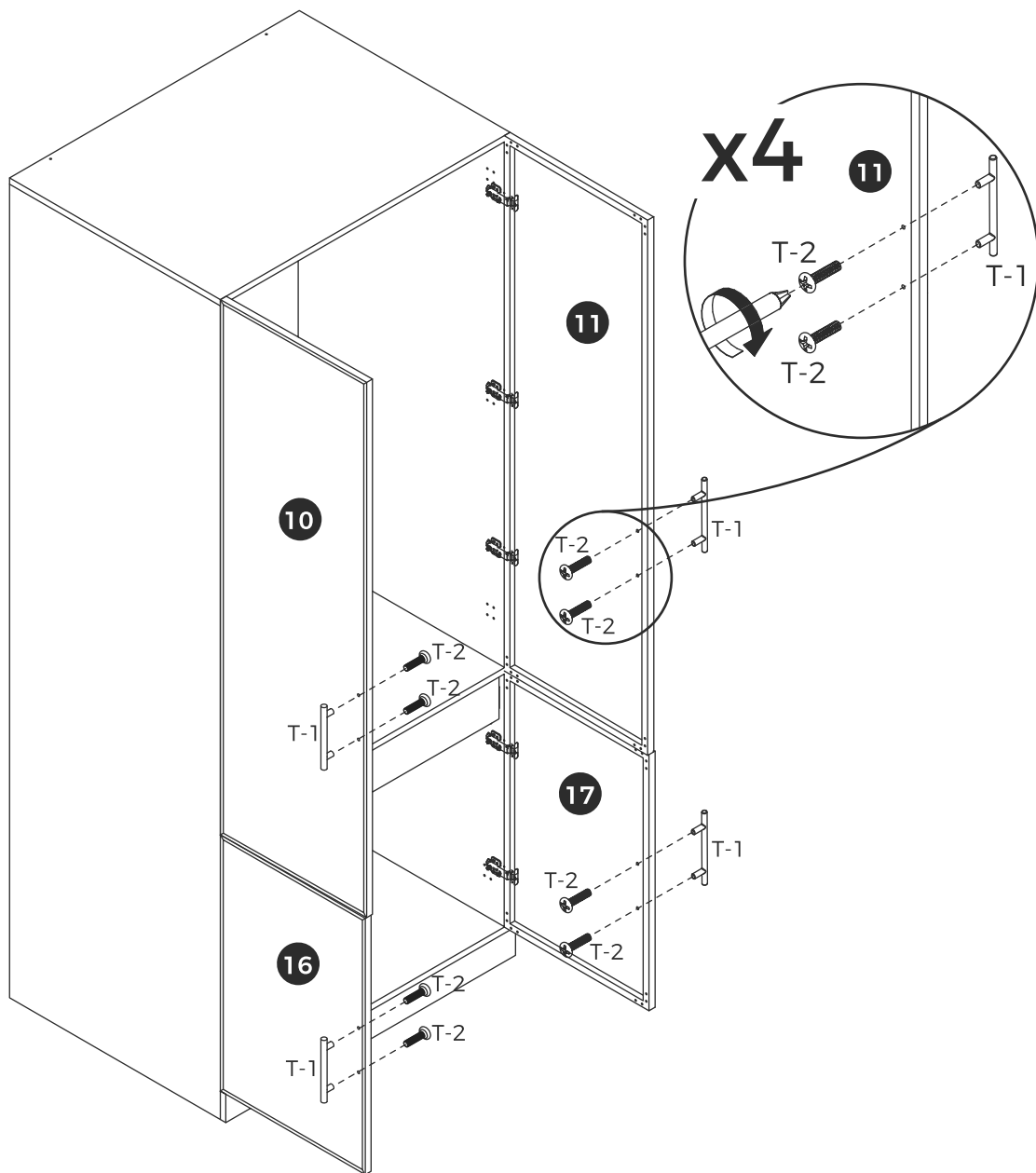

26



[EN] Insert clip J-1 into back slots and secure with screw J-2.

[ES] Inserte el clip J-1 en las ranuras traseras y fíjelo con el tornillo J-2.

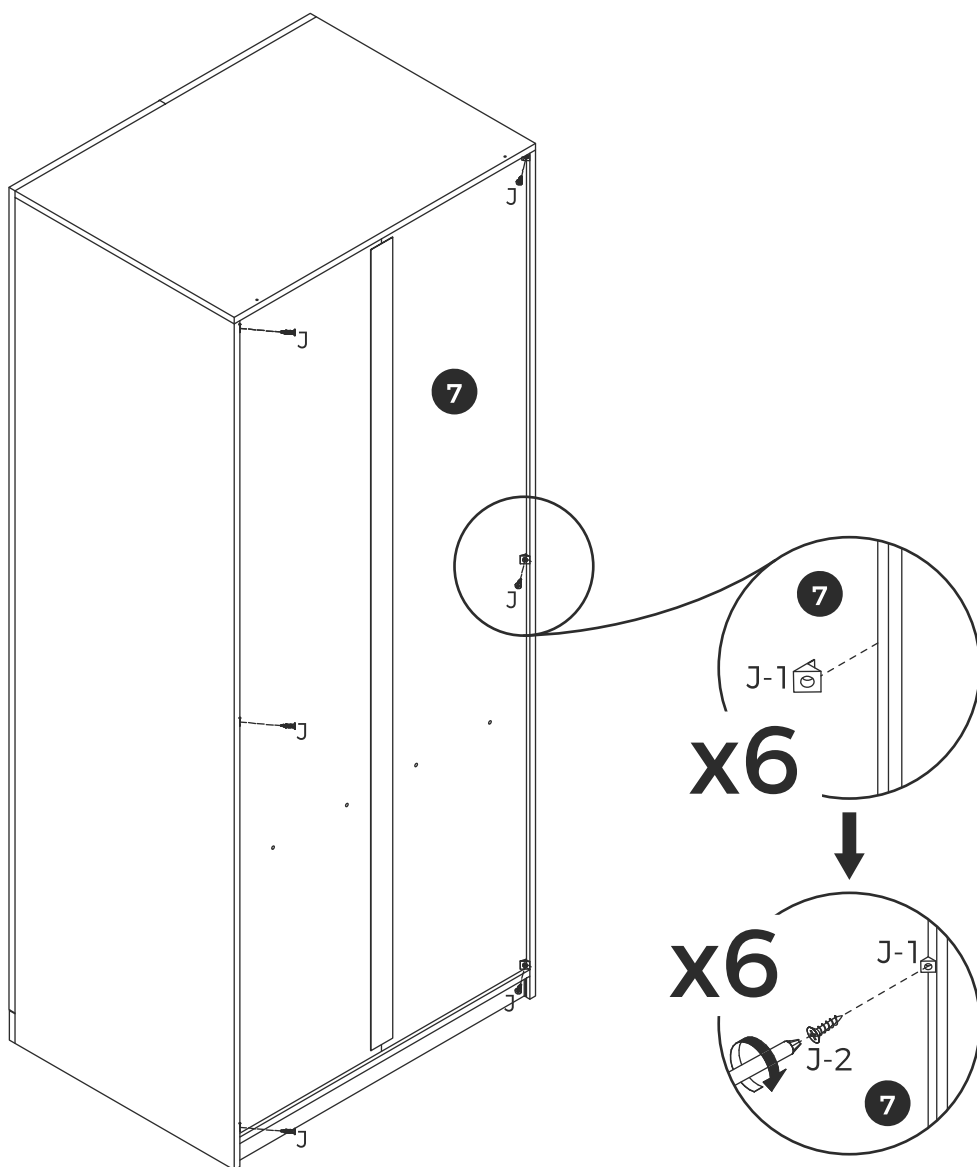

27

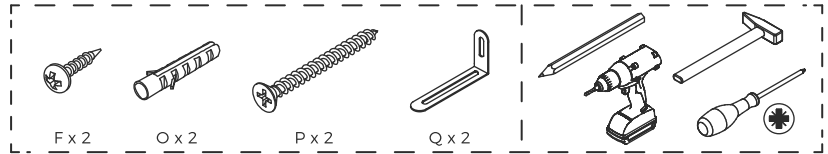

[EN] Install the anti-tilt device.

[ES] Instale el dispositivo antivuelco.

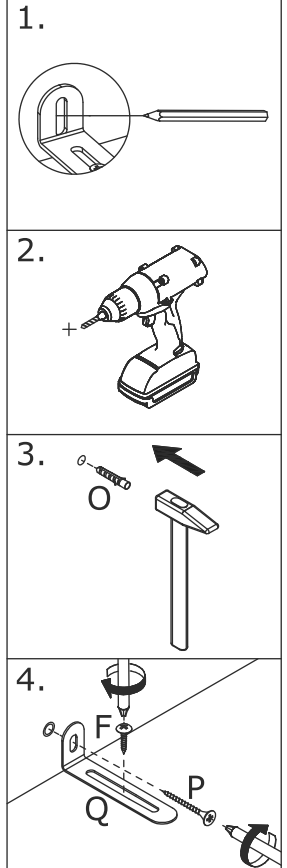
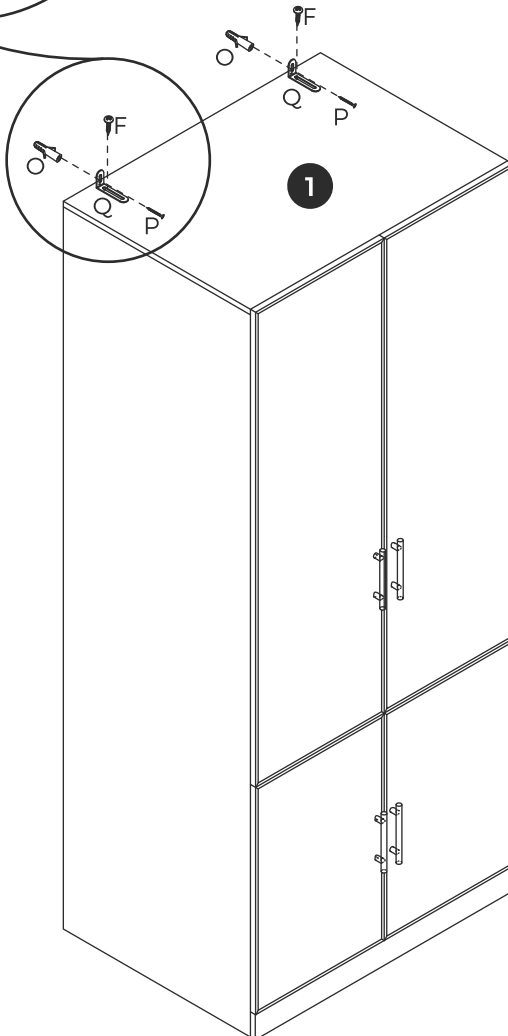
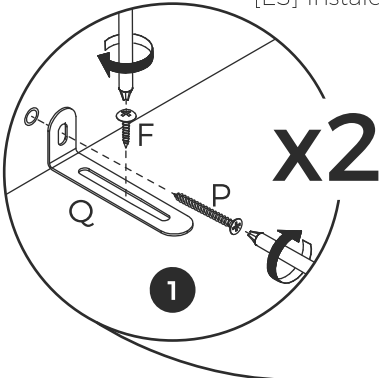

28



[EN] If the doors are not aligned after installation, watch the video. Adjust the hinge screws as needed to achieve proper alignment.

[ES] Si las puertas no están alineadas después de la instalación, vea el video. Ajuste los tornillos de las bisagras según sea necesario para lograr una alineación correcta.

