

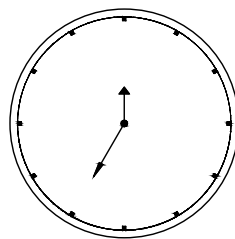

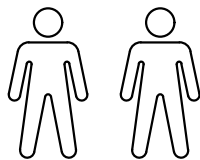

ASSEMBLY INSTRUCTION

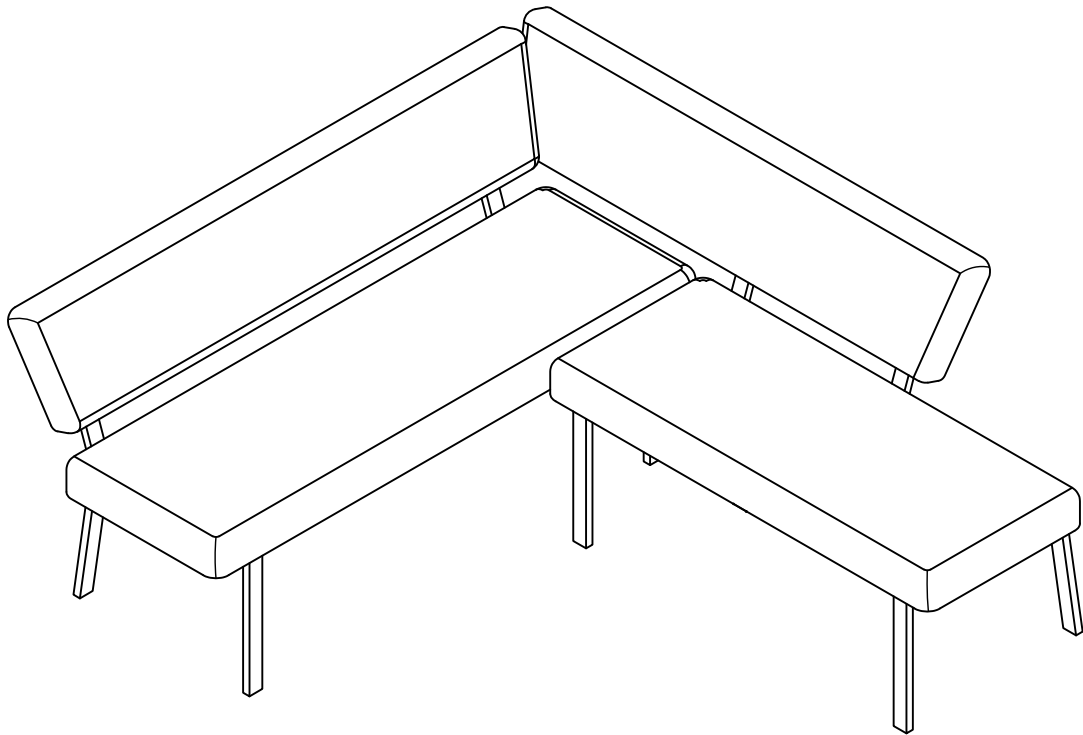

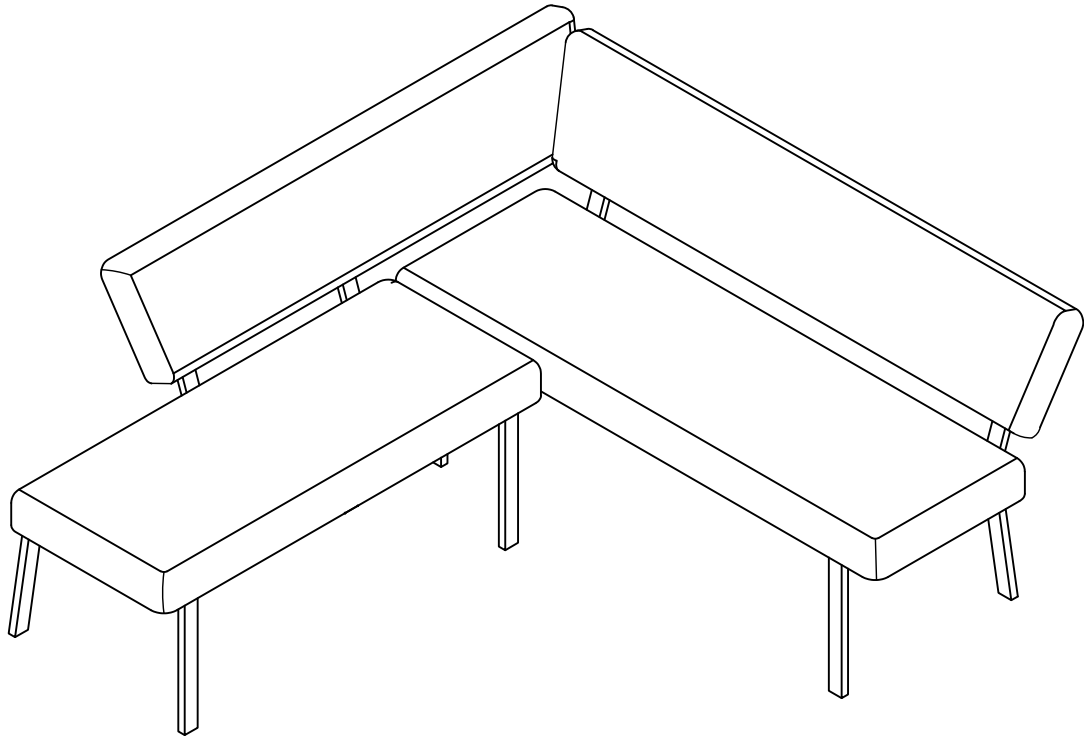
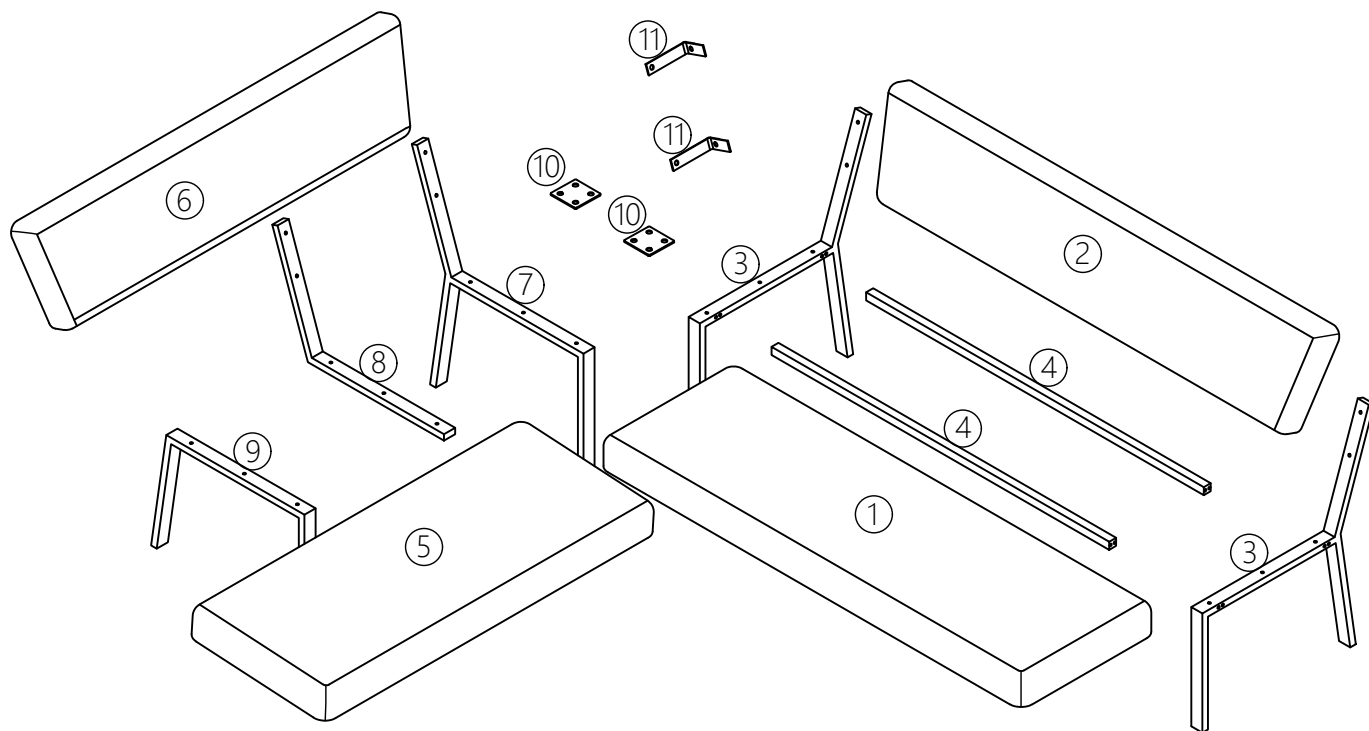

A	x 8+1	B	x 23+1	C	x 12+1	D	x 1
							
M6x60		M6x35		M6x15		M4	

①x1pc

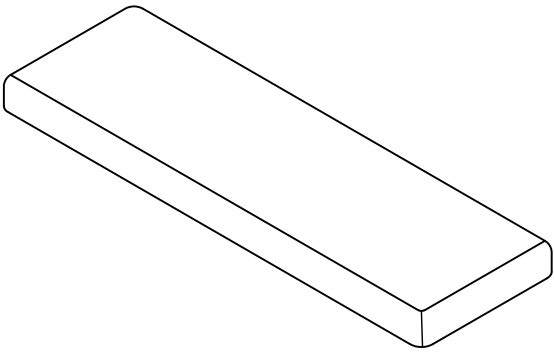

②x1pc

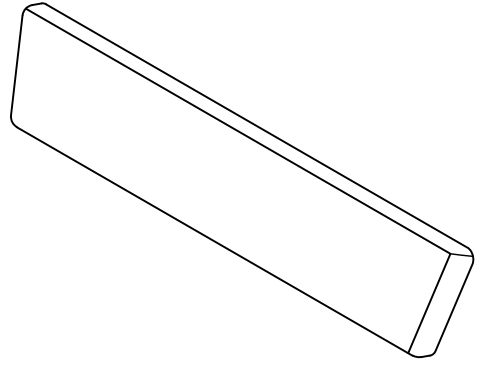

③x2pcs

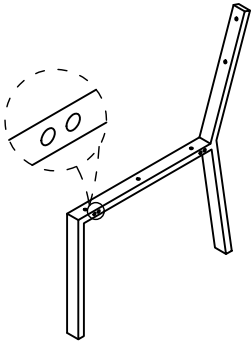

④x2pcs

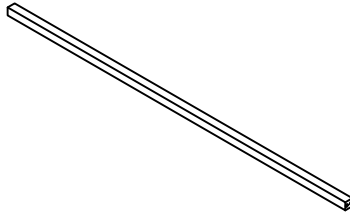

⑤x1pc

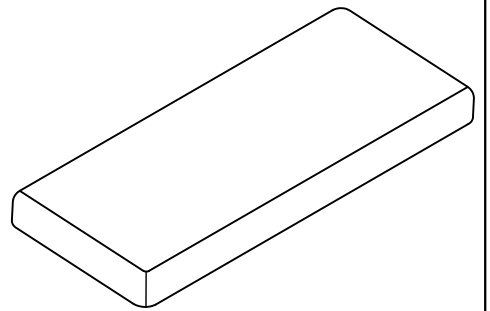

⑥x1pc

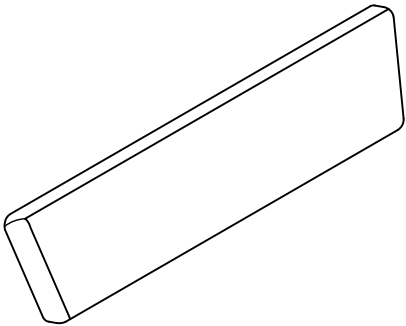

⑦x1pc

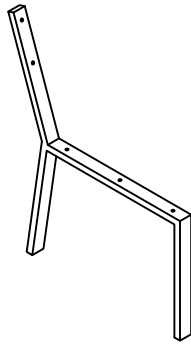

⑧x1pc

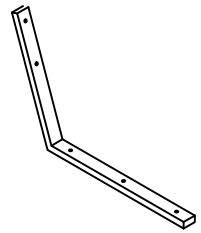

⑨x1pc

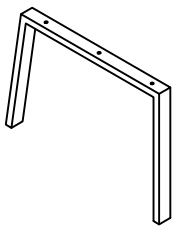

⑩x2pcs

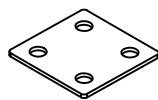

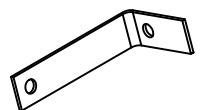

⑪x2pcs



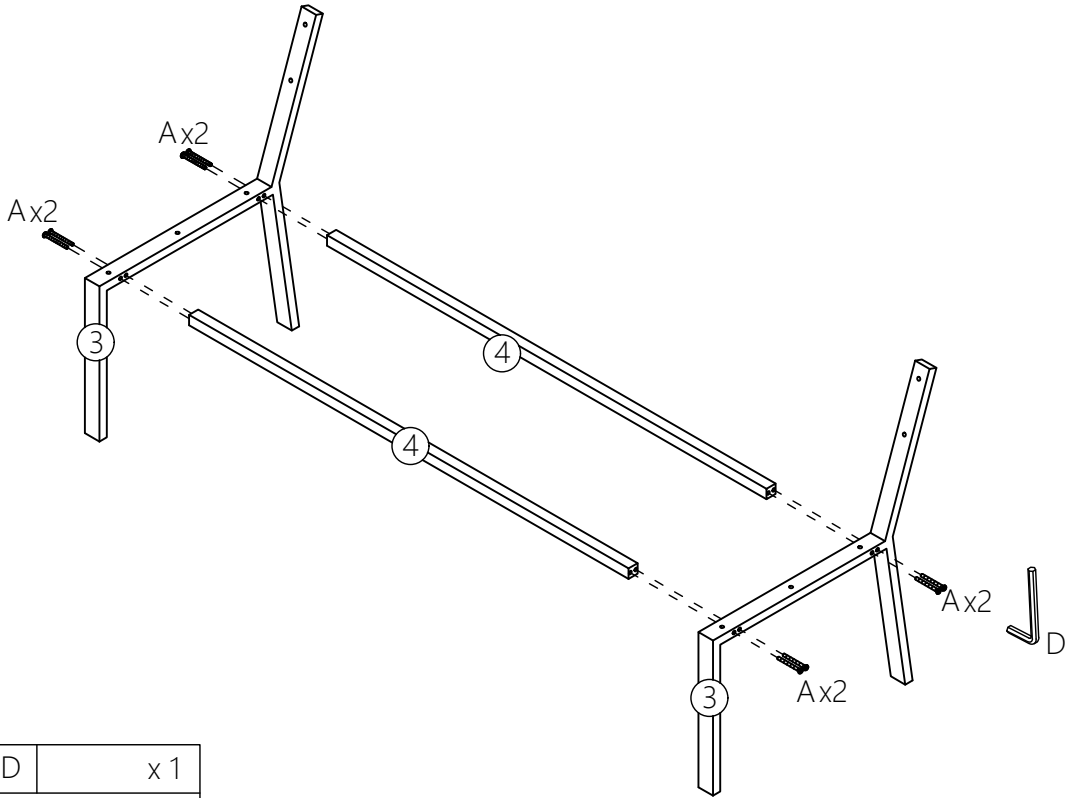

1



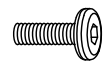

A	x 8	D	x 1
			
M6x60		M4	

2

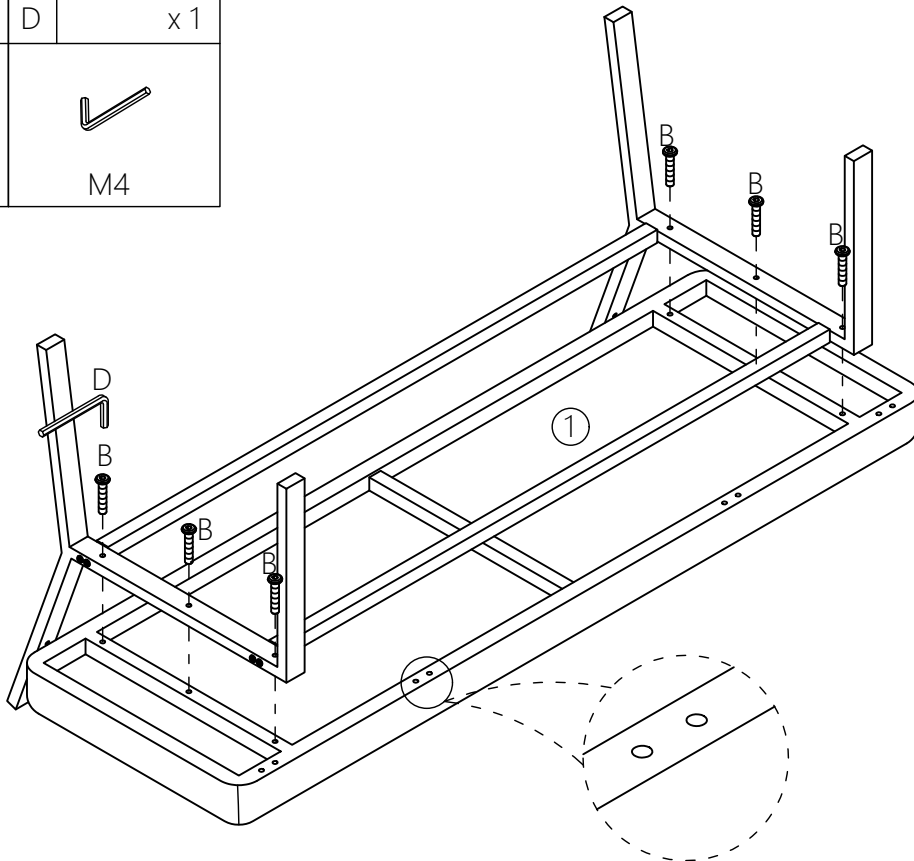
B	x 6	D	x 1
			
M6x35		M4	



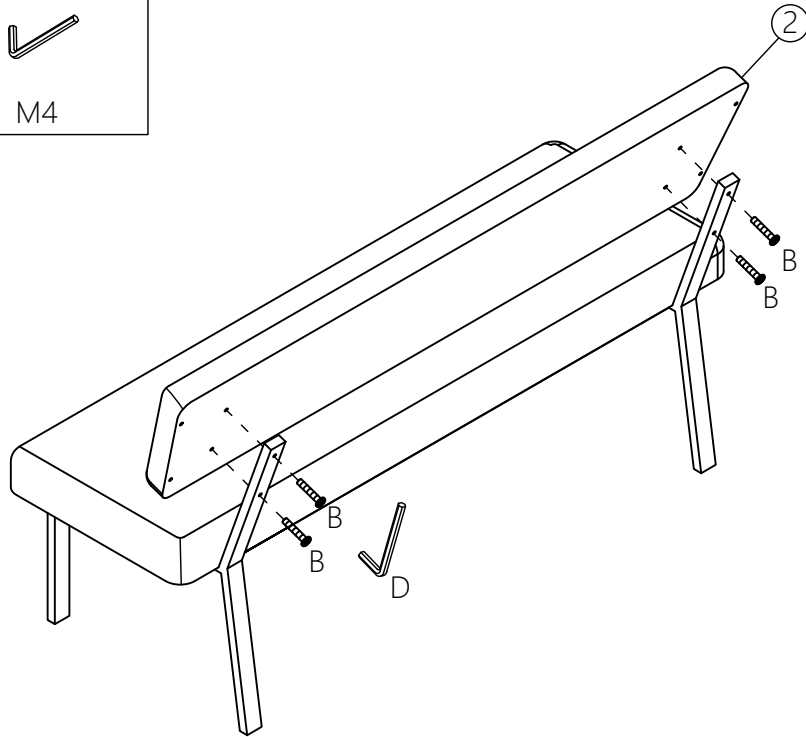

3

B	x 4	D	x 1
			
M6x35		M4	





! Note: Align the screw holes and then tighten the screws.

4

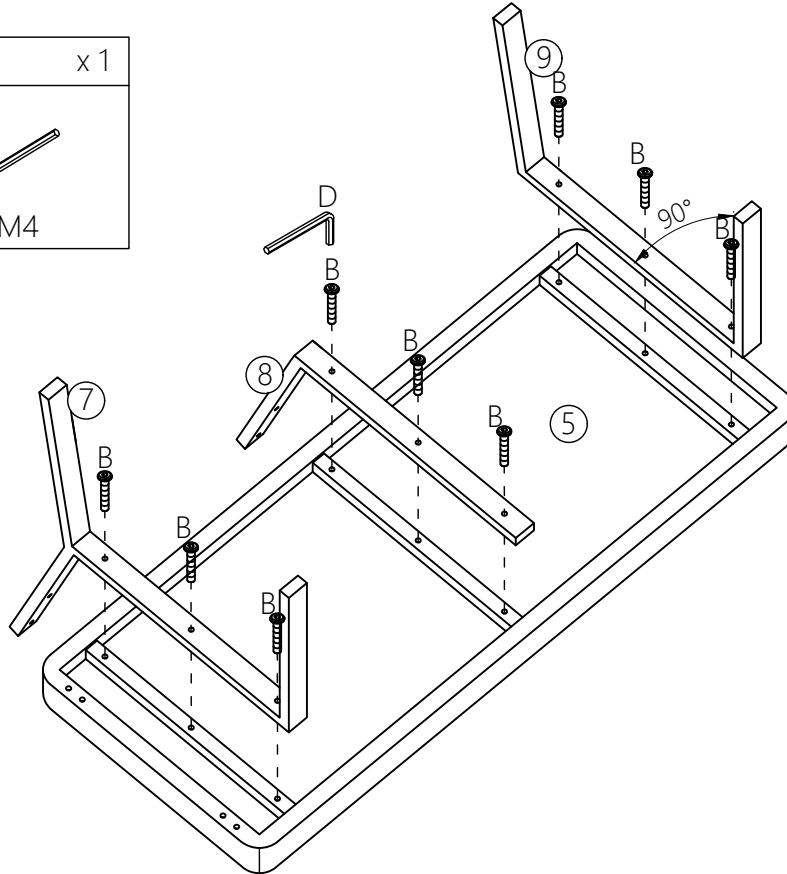
B	x 9	D	x 1
			
M6x35		M4	



5

B	x 4	D	x 1
			
M6x35		M4	

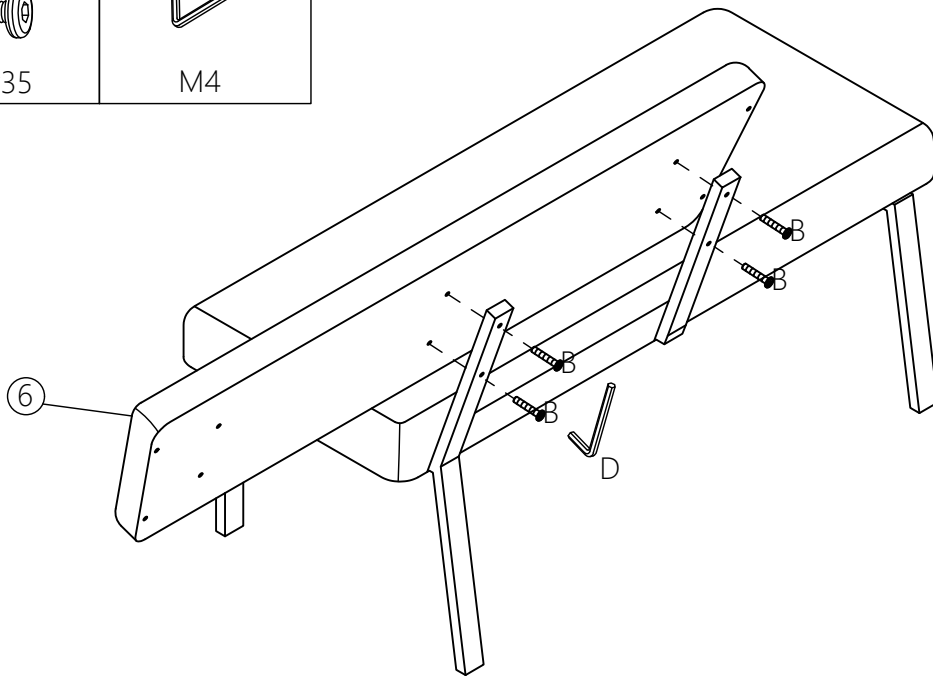

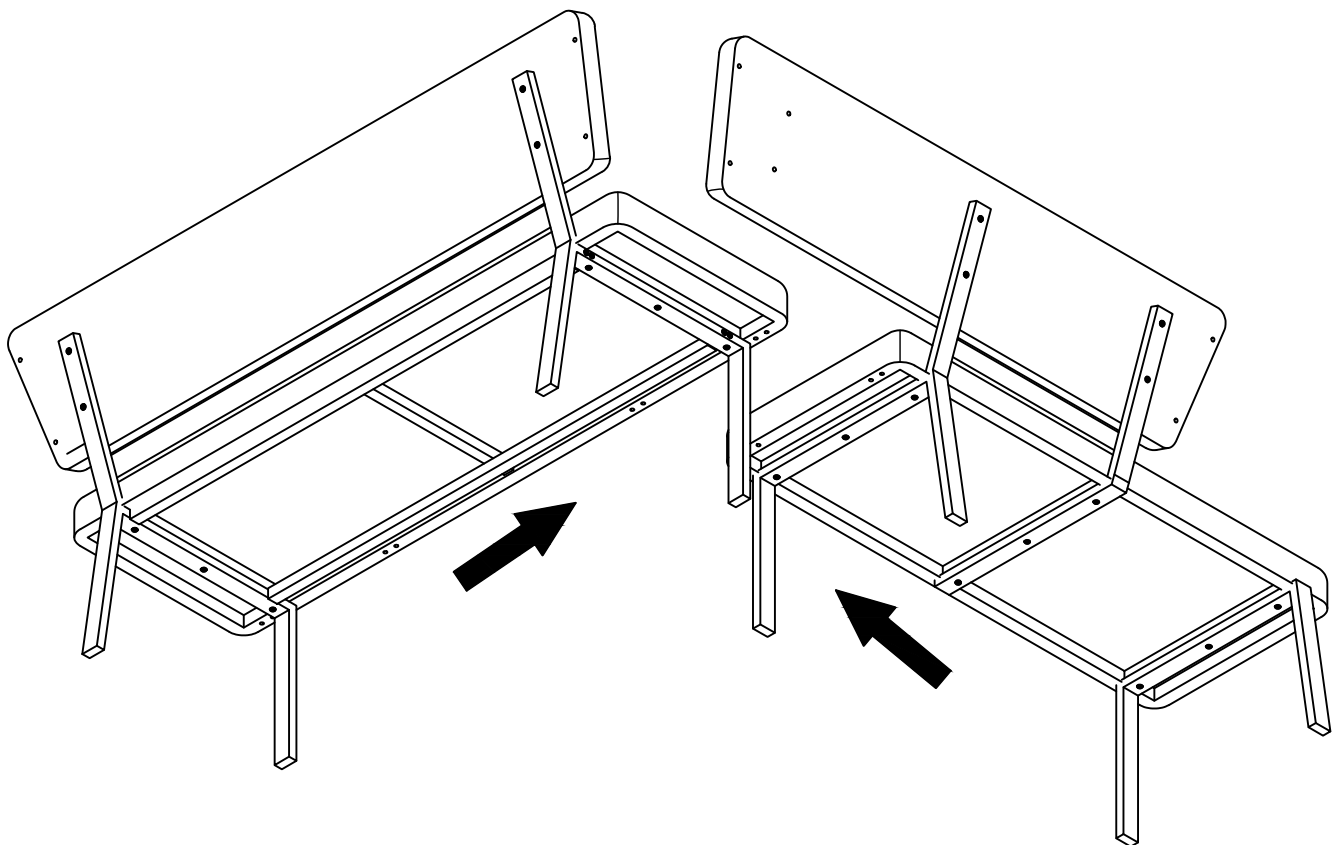

! Note: Align the screw holes and then tighten the screws.

6



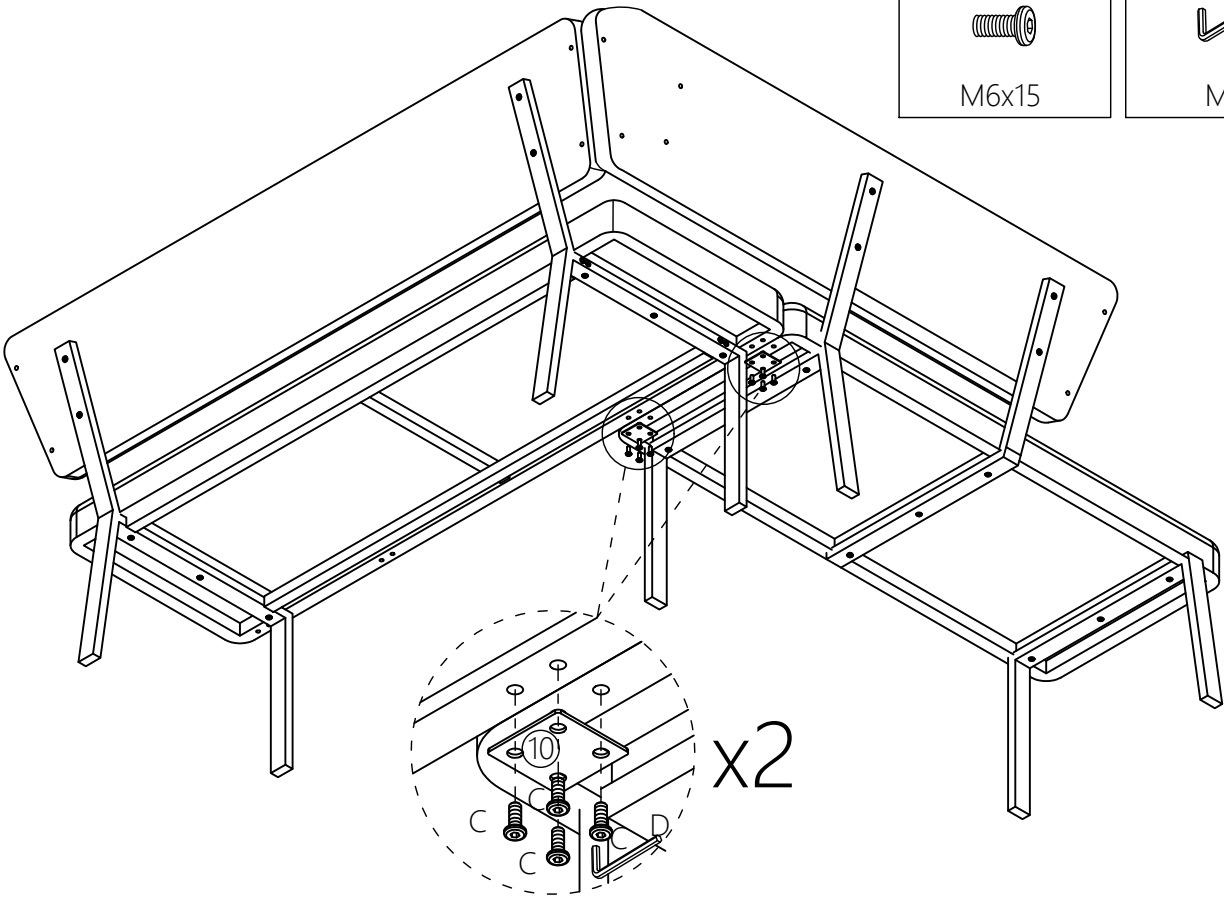

7

C	x 8	D	x 1
			
M6x15		M4	



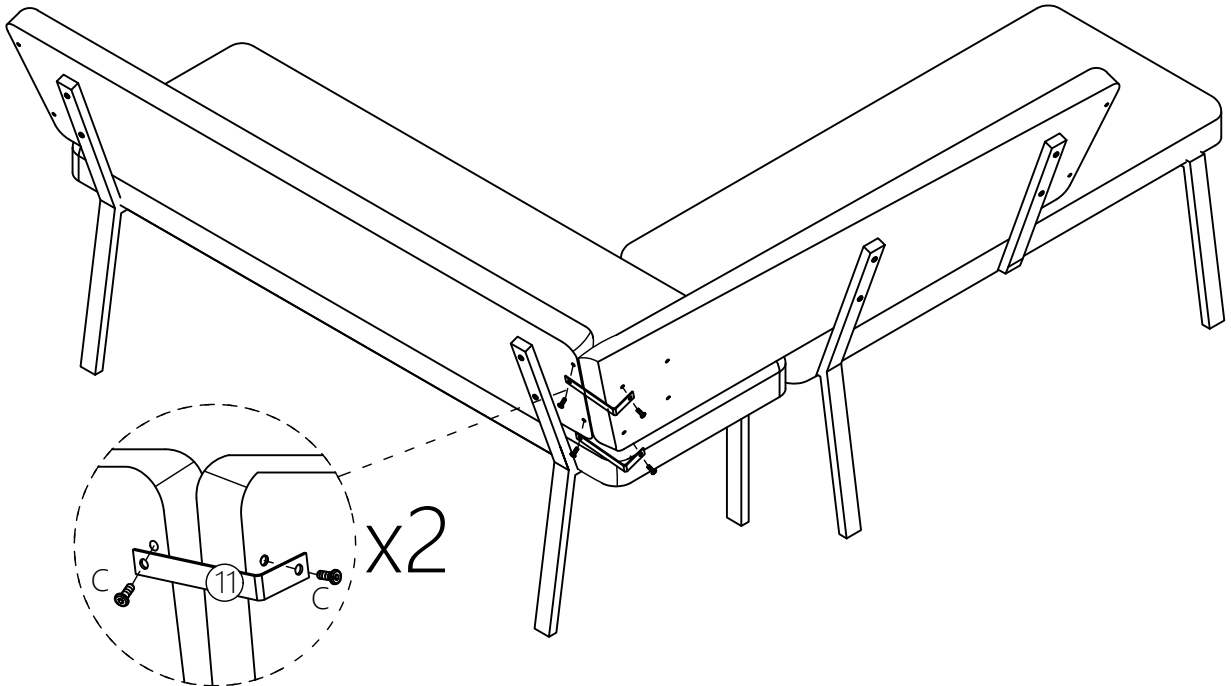

8

C	x 4	D	x 1
			
M6x15		M4	

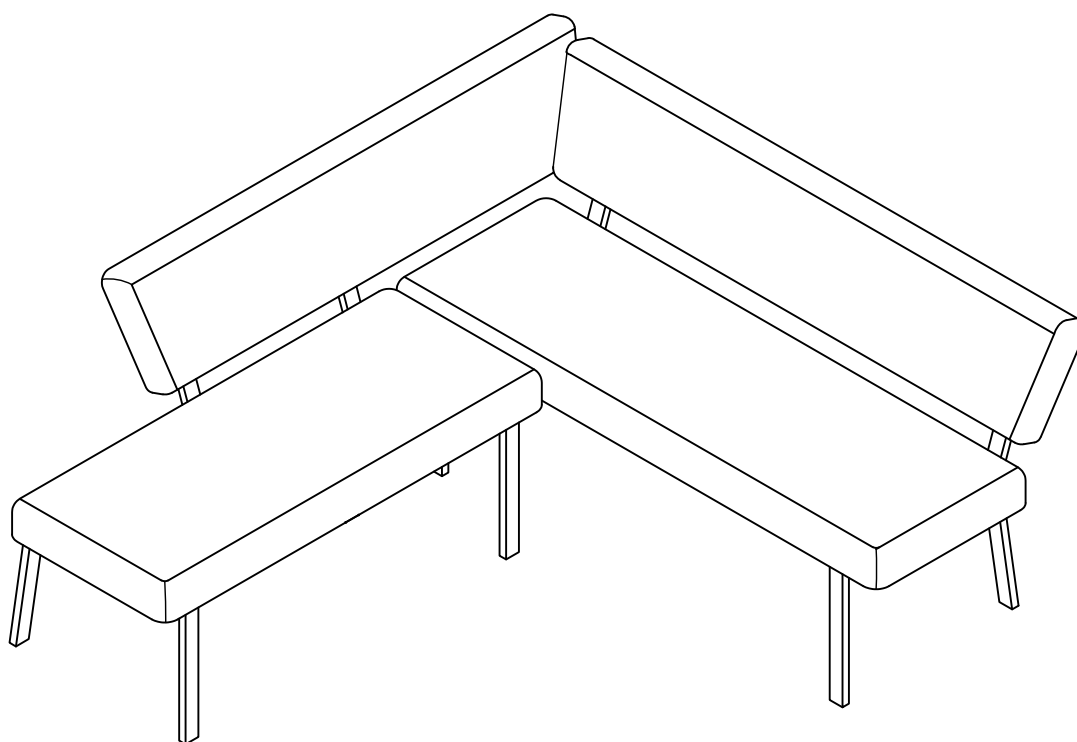



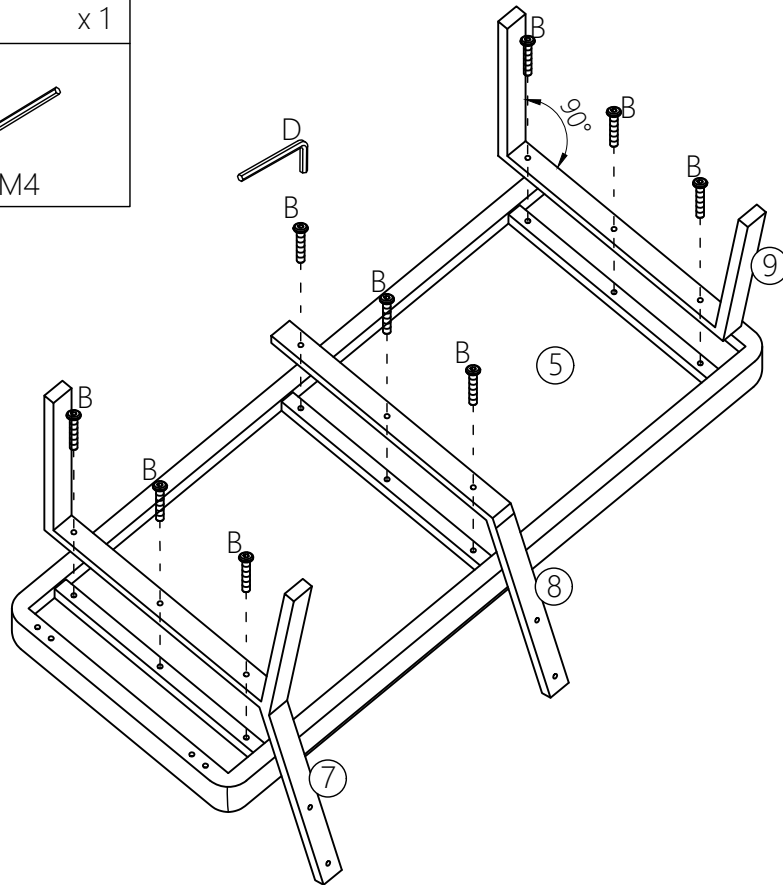

10

B	x 9	D	x 1
			
M6x35		M4	



11

B	x 4	D	x 1
			
M6x35		M4	

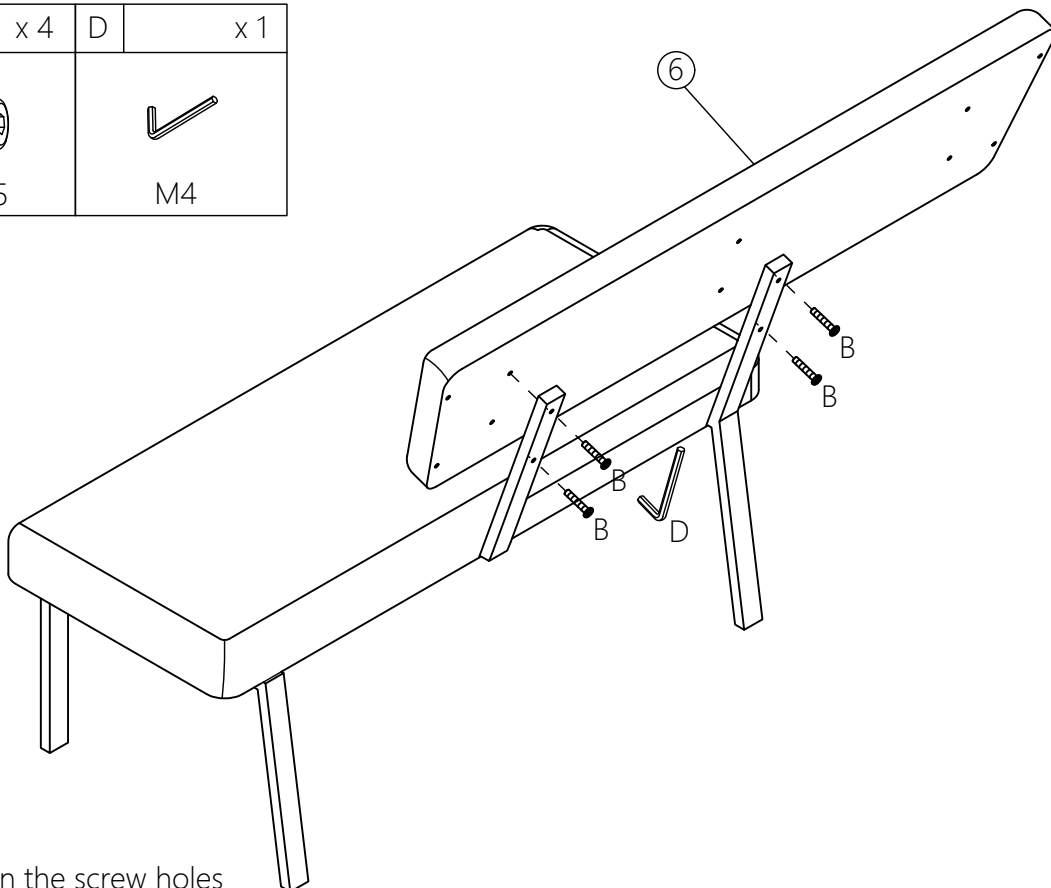

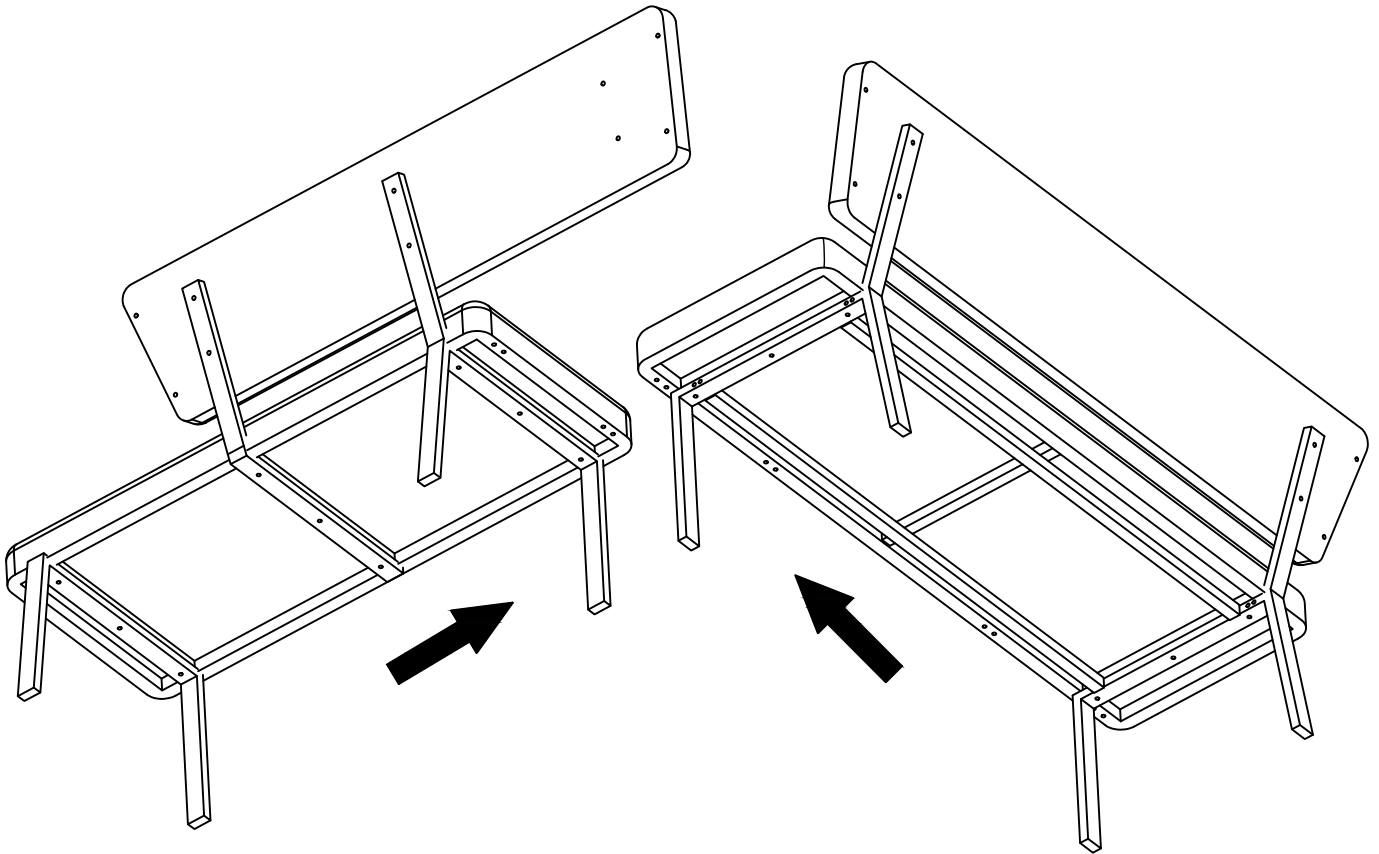

! Note: Align the screw holes and then tighten the screws.

12



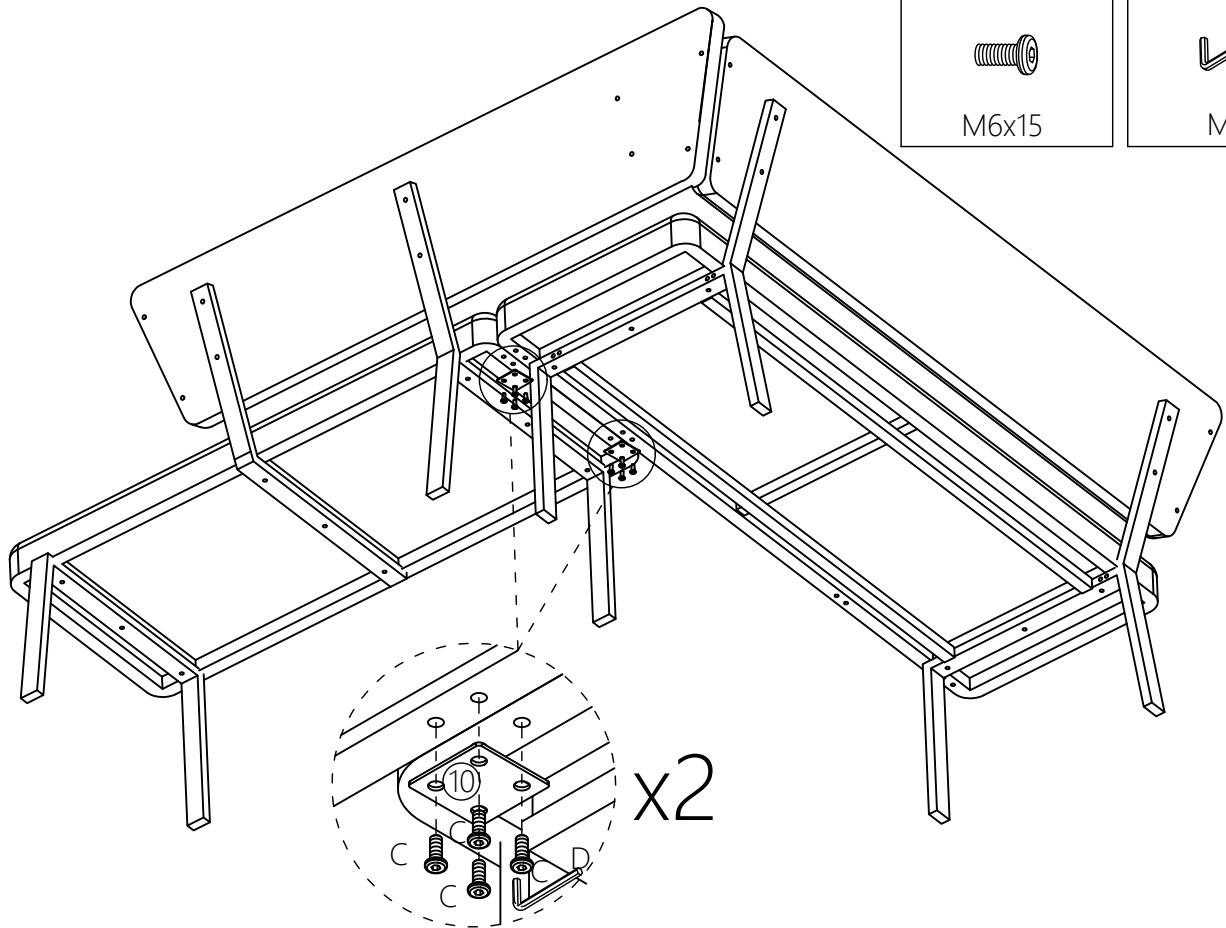

13



C	x 8	D	x 1
			
M6x15		M4	

14

C	x 4	D	x 1
			
M6x15		M4	

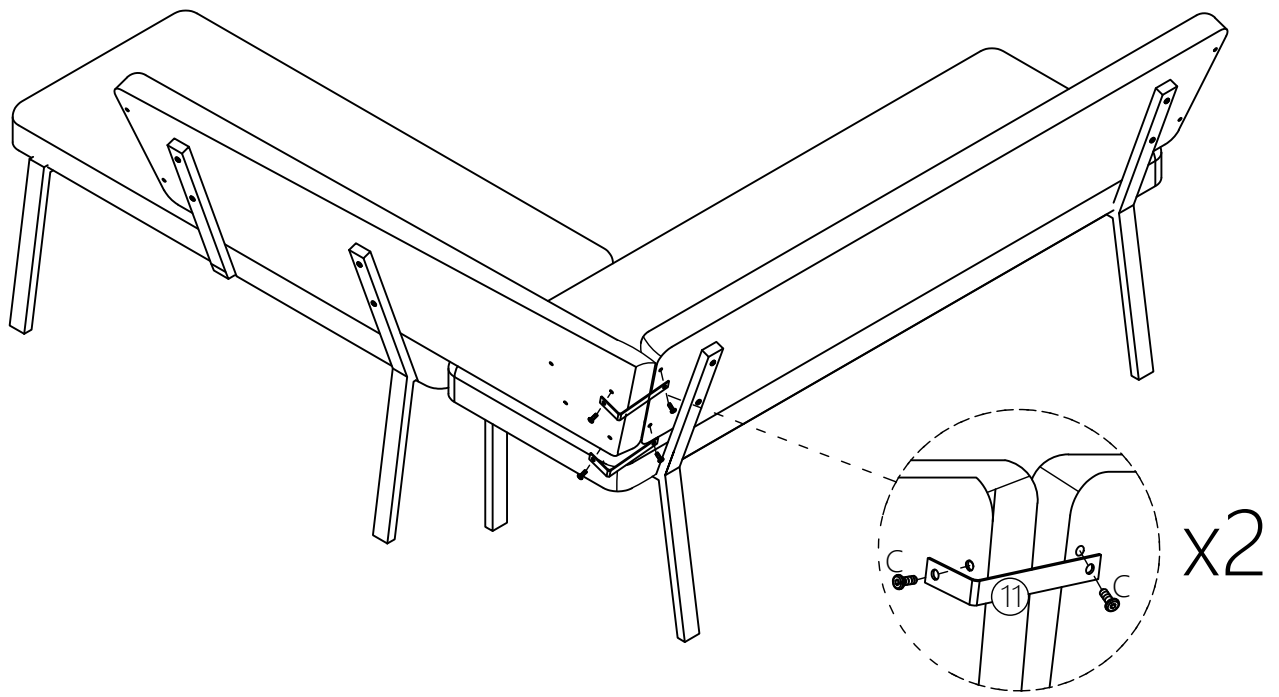

15

