

ASSEMBLY INSTRUCTIONS

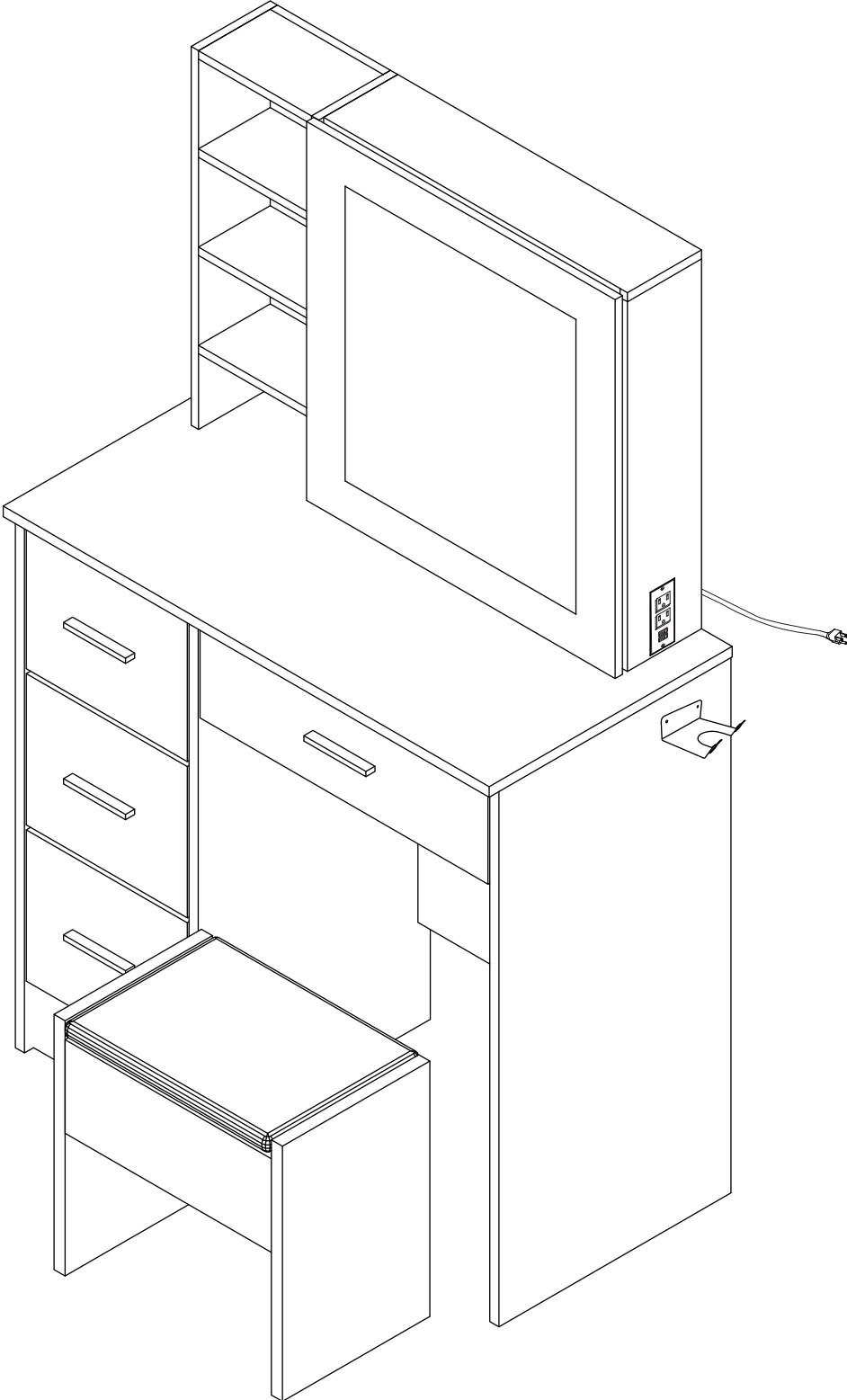

ASSEMBLY GUIDE

Before enjoy the comfort chair, you have to put it together. This Assembly Guide will take you through the basic assembly process. To make sure your assembly goes smoothly, please follow the assembly instructions, **and especially the important safety information.**

Also, while it is possible to assemble the chair on your own, **having a second person to help you makes it even easier.**







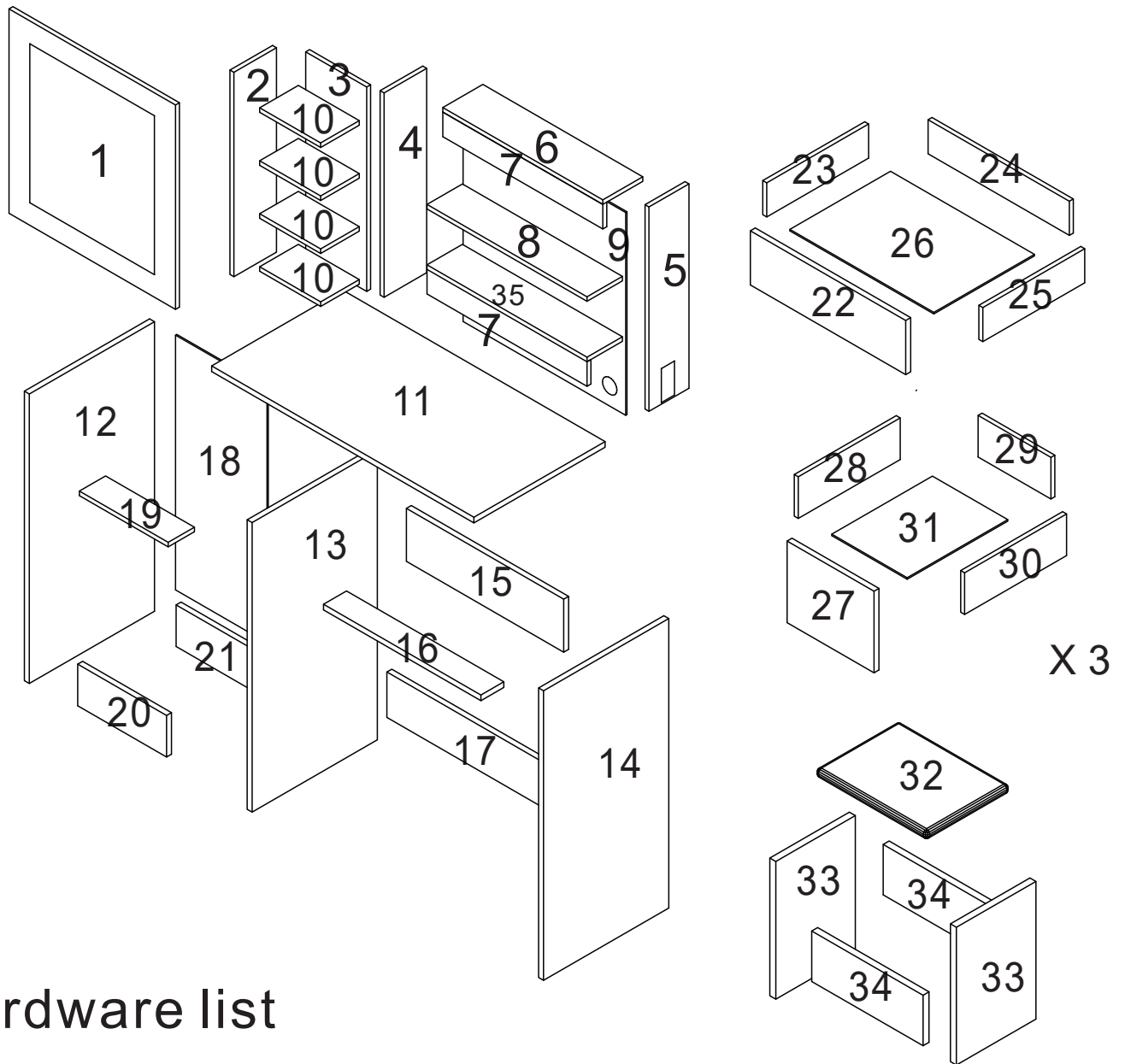

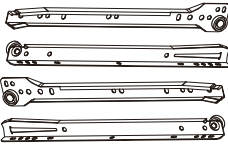
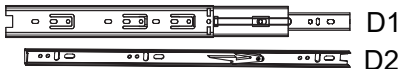

Before you begin, please check if there are any missing parts from the package. Should there be any issues, please don't hesitate to drop us an email and we'll help you out ASAP.

If you run into any difficulty during the assembly, remember to check out the Assembly Video to see if you've missed anything. If you're unable to resolve your problems, drop us an email as well and our support team will assist you.

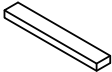
Part list

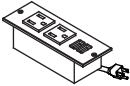

Hardware list

A		X 62	B		X 52
C		X 4	D		X 2
E		X 53	F		X 4
G		X 8	H		X 1
J		X 2	I		X 1
K		X 2			

STEP 1

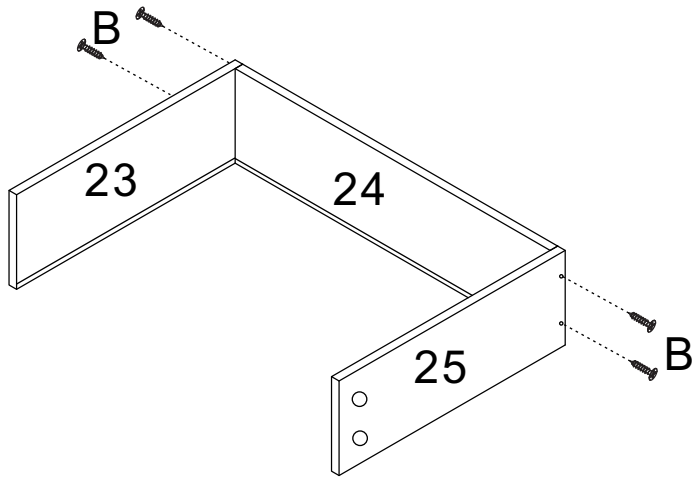

B X 4

STEP 2

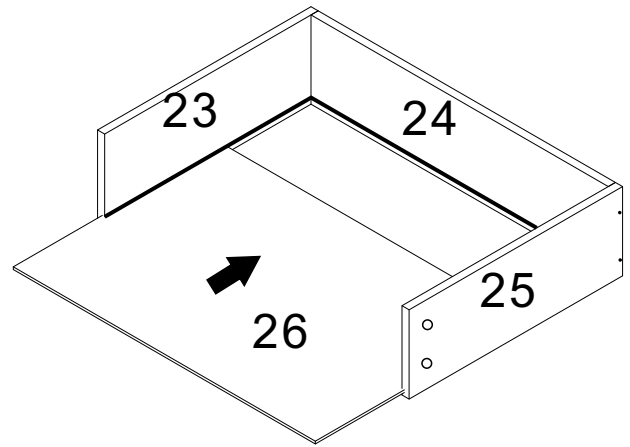

STEP 3

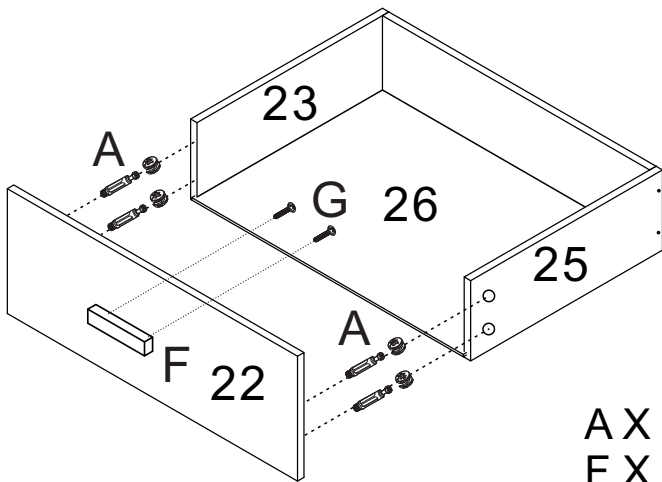

A X 4
F X 1
G X 2

STEP 4

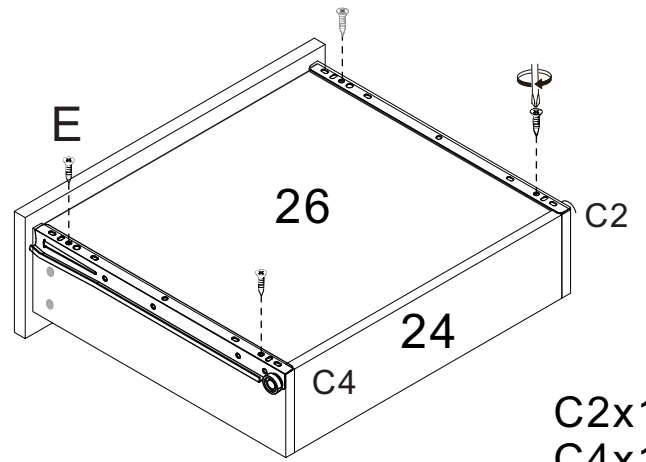

C2x1
C4x1
E x4

STEP 5

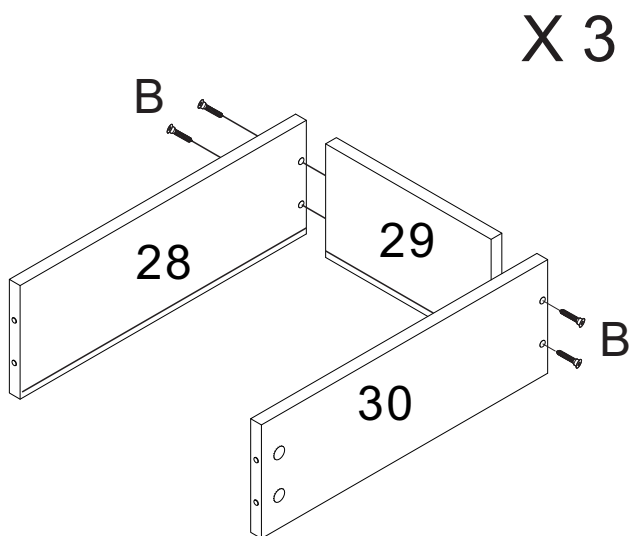

X 3

B x 12

STEP 6

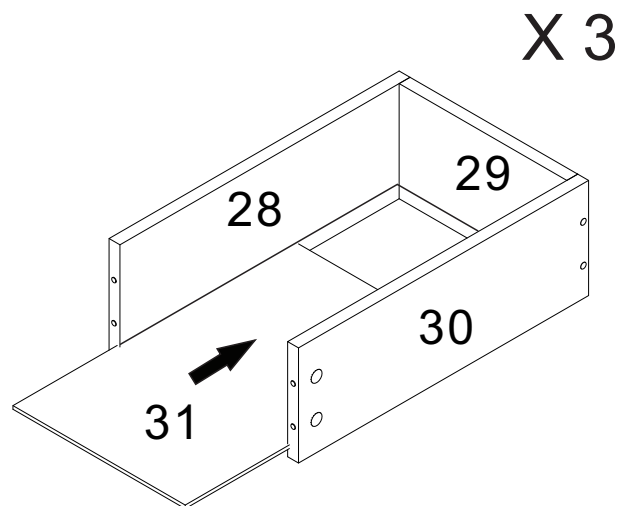

X 3

STEP 7

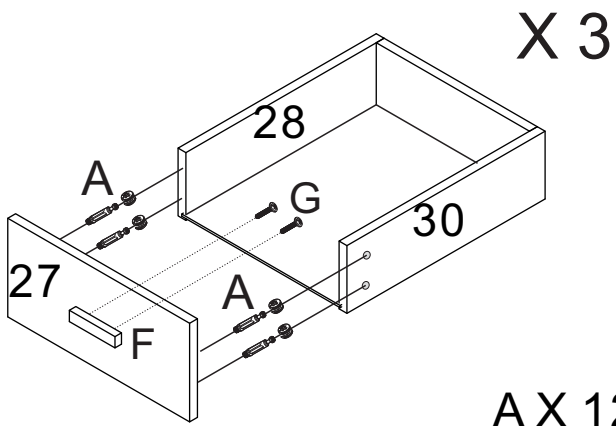

AX 12
FX 3
GX 6

STEP 8

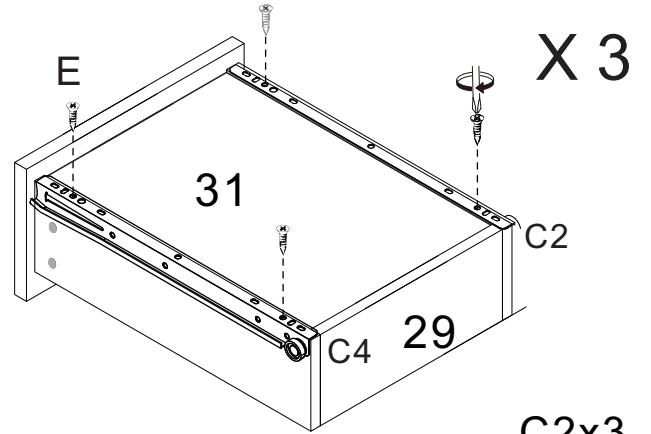

C2x3
C4x3
E x12

STEP 9

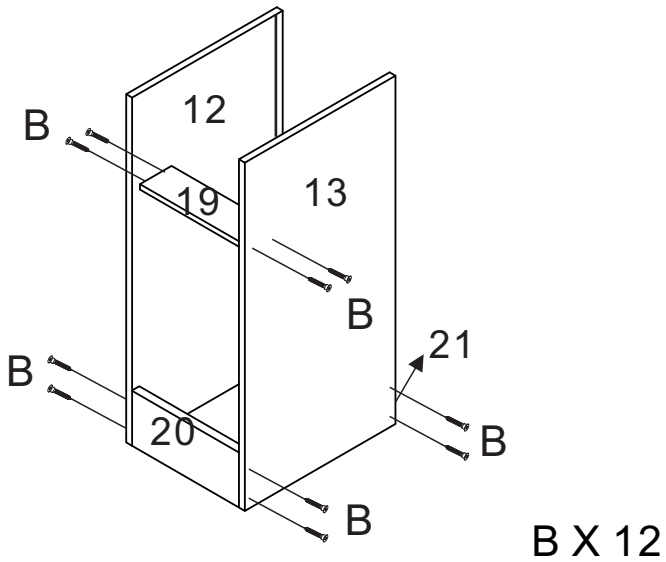

STEP 10

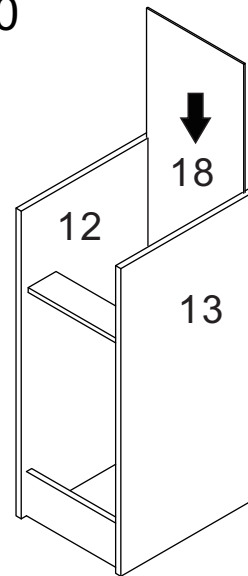

STEP 11

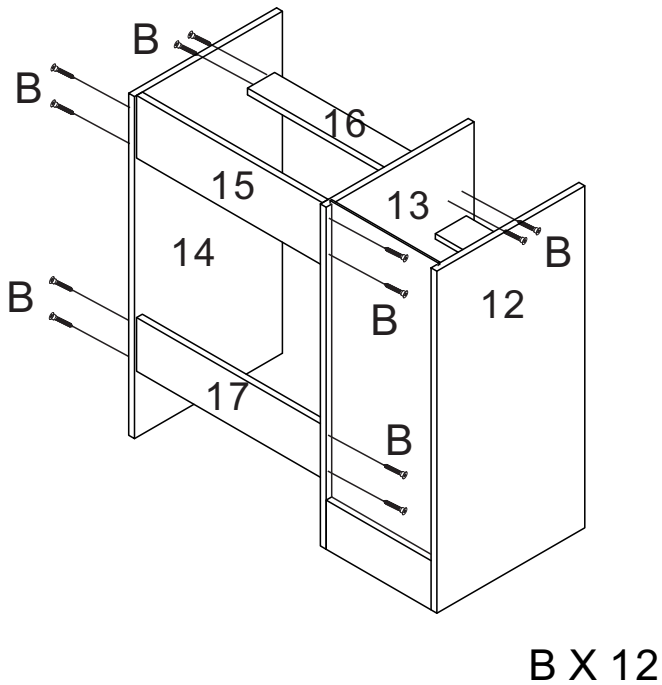

STEP 12

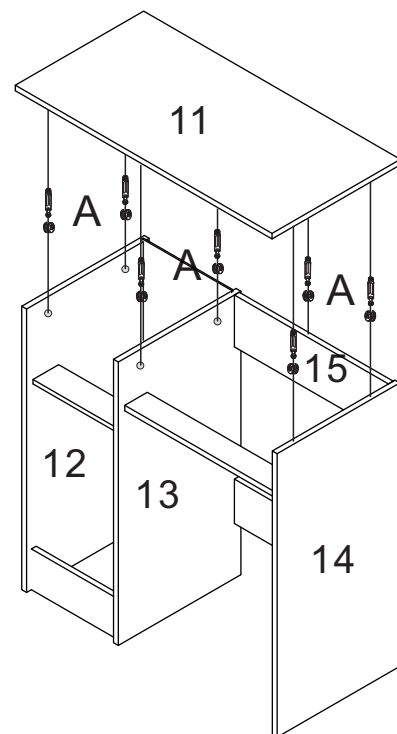

AX 7

STEP 13

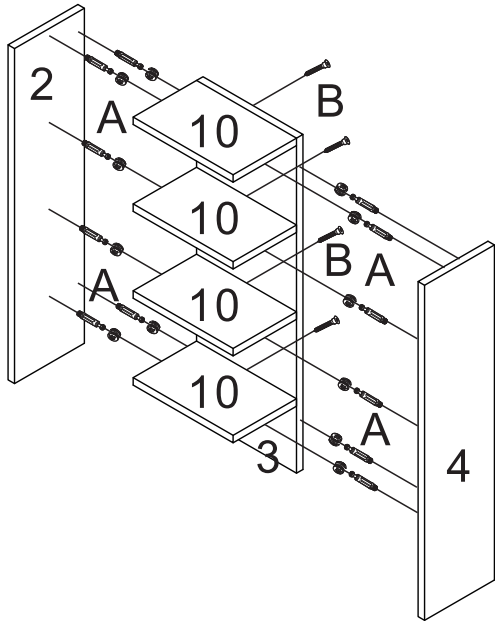

Ax12
Bx4

STEP 14

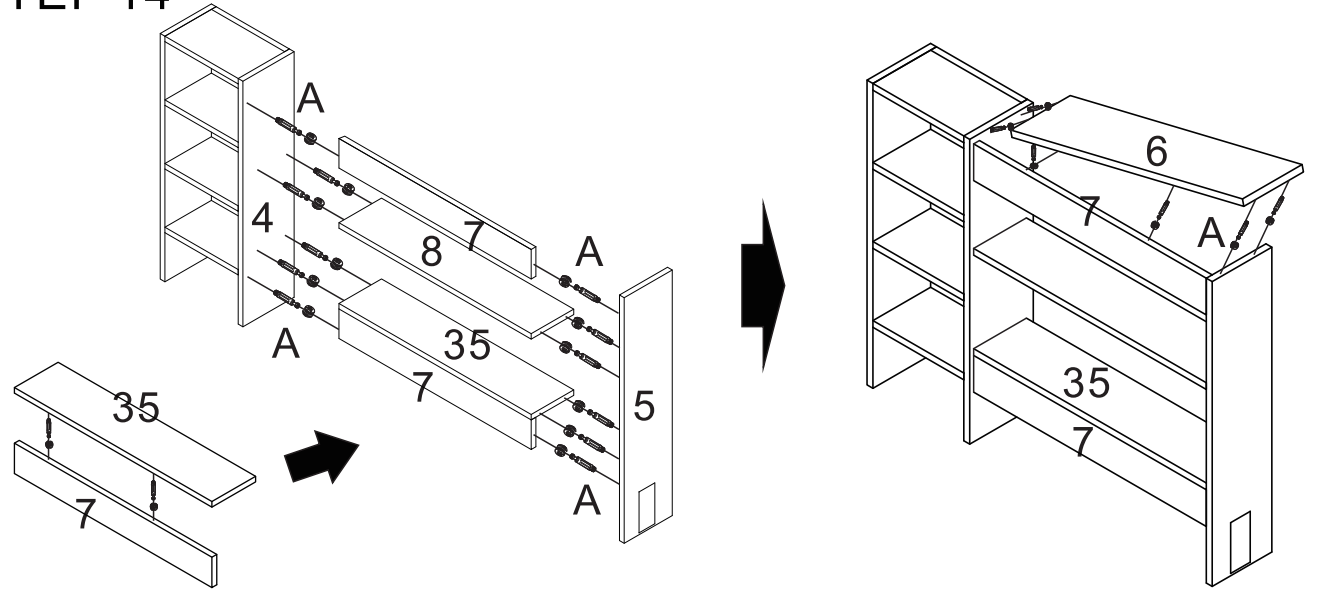

A X20

STEP 15

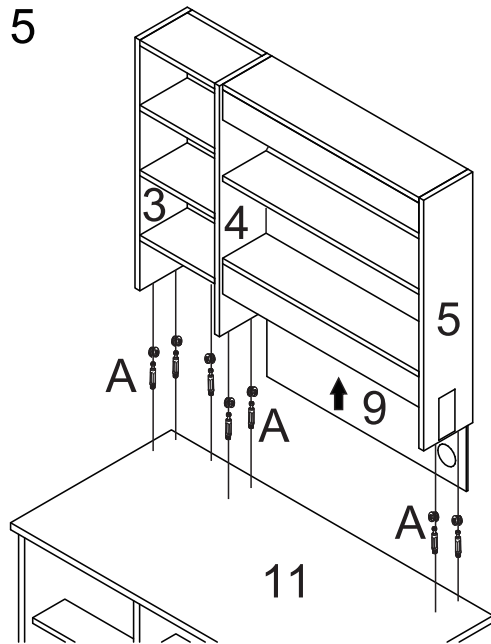

Ax7

STEP 16

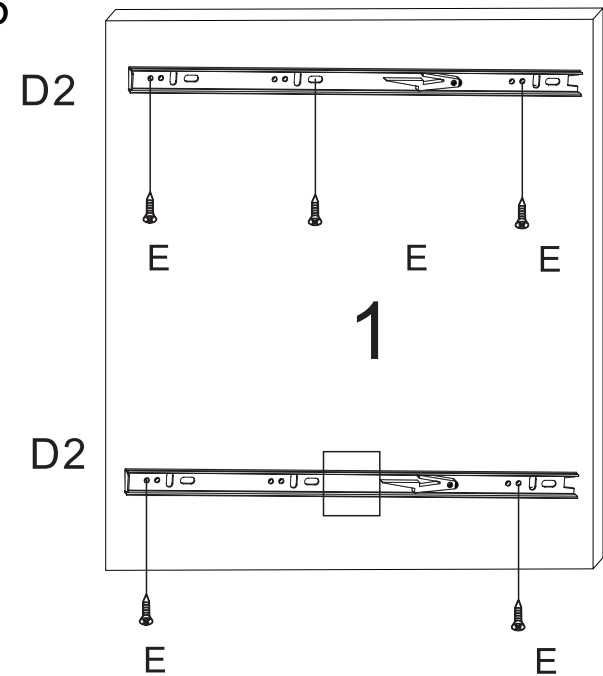

D2x2
E x5

STEP 18

C1

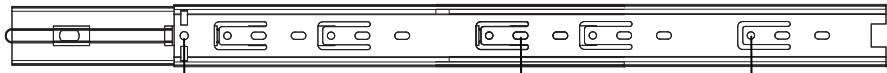
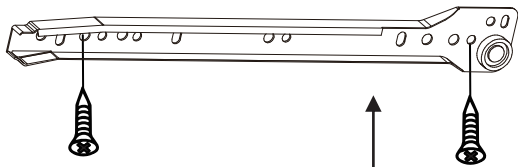

D1



C3

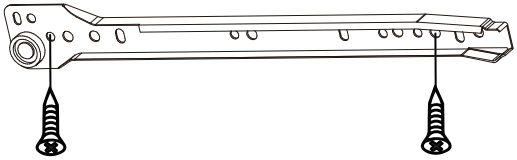

E

E

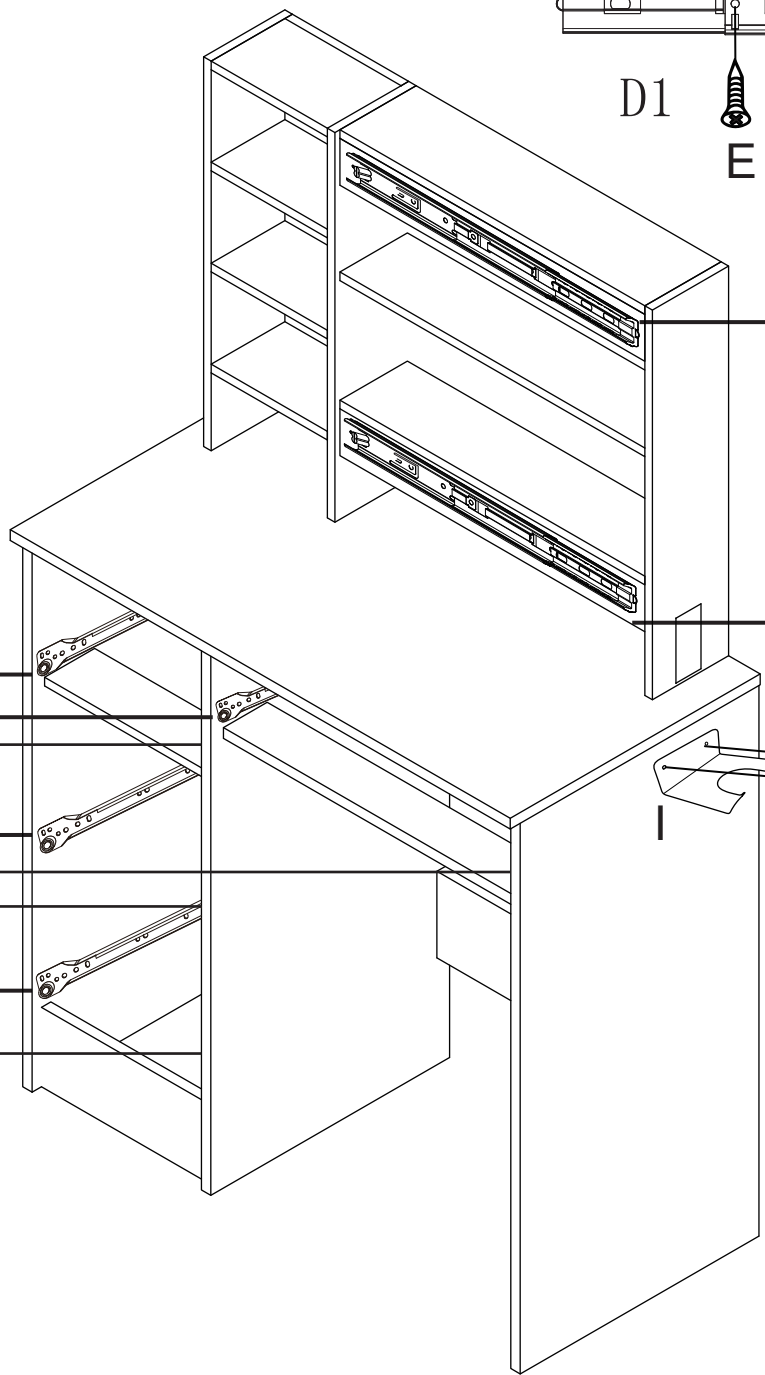

Free adjustment of hole position

- C1 X 4
- C3 X 4
- I X 1
- K X 2
- D1 X 2
- E X 22

STEP 19

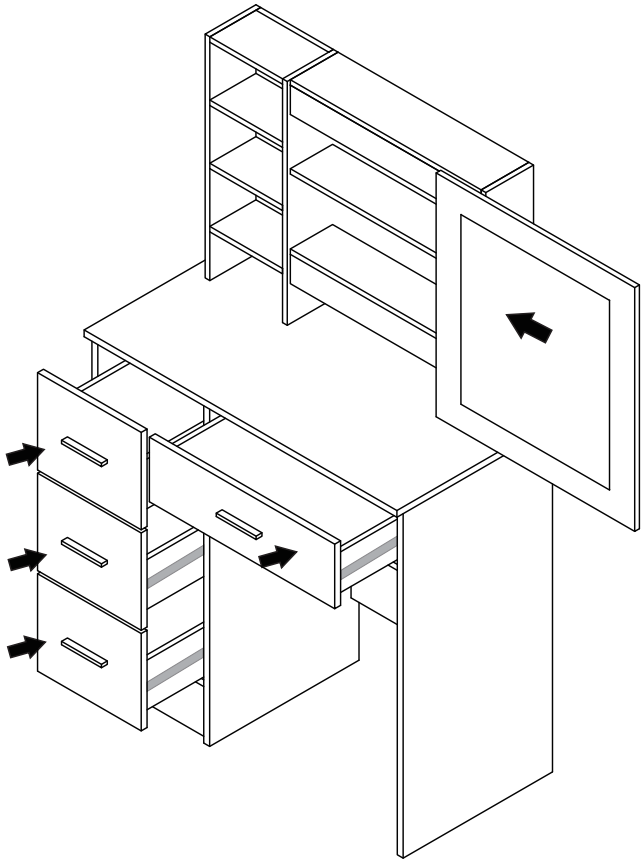

STEP 20

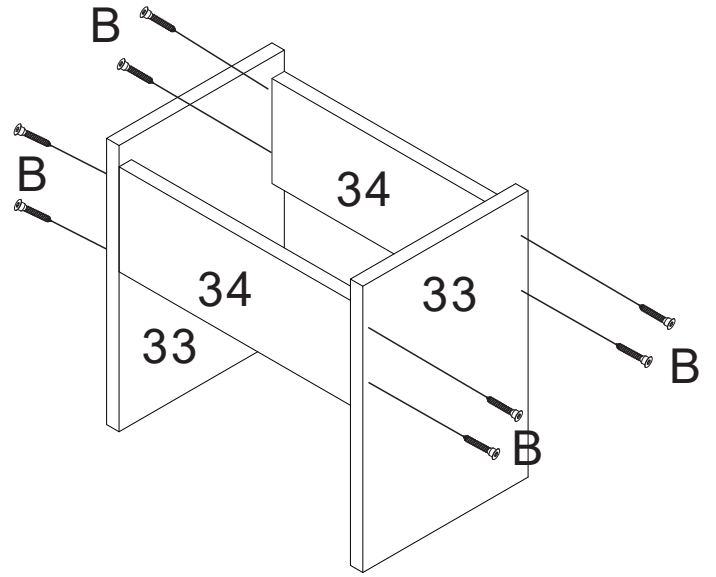

B X 8

STEP 21

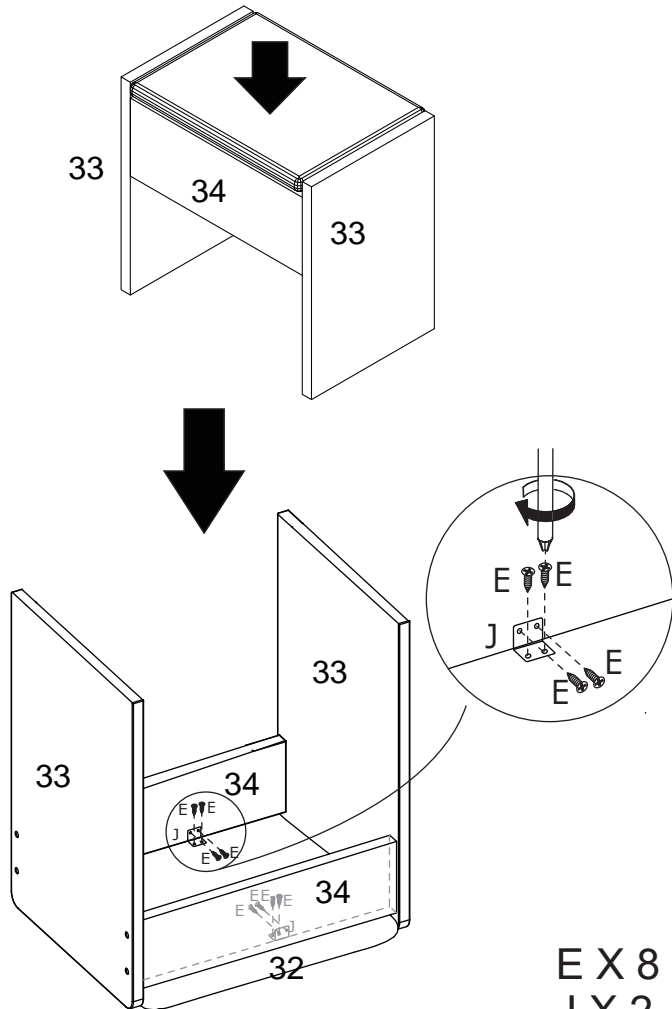

EX 8
JX 2

STEP 22

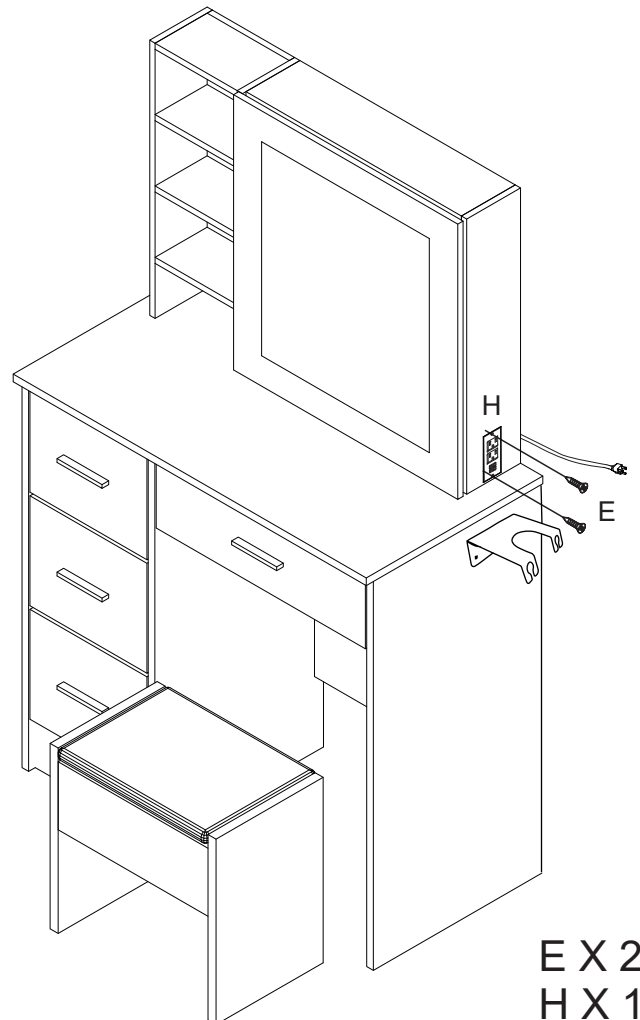

EX 2
HX 1

Dear customer,

Thank you for choosing our product ! We want to assure you that we have conducted thorough quality inspections before shipping to ensure the best product condition. However, we understand that unforeseen circumstances during transportation may sometimes result in potential damage.

If there are any issues with your received goods, please reach out to us without hesitation. Our dedicated customer service team is here to assist you and will promptly arrange the delivery of replacement parts if needed.

We apologize for any inconvenience this may have caused and sincerely appreciate your understanding. Your satisfaction is our highest priority, and we are committed to addressing any concerns or queries you may have after your purchase.

Thank you for your patience and trust in our product. We will do everything we can to ensure you have a positive experience with our products.

Best regards,
Customer Service Team

STEP1: First, log in to your Amazon account. Click on the "Order" tab located on the website or app.

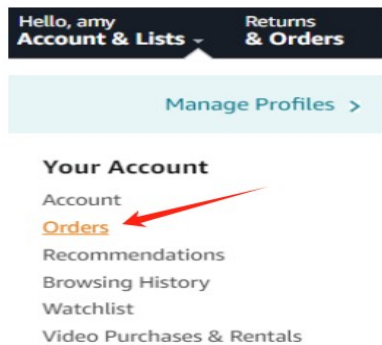

Step 2: Once you are on the order details page, look for the "Problem with Order" button and click on it.

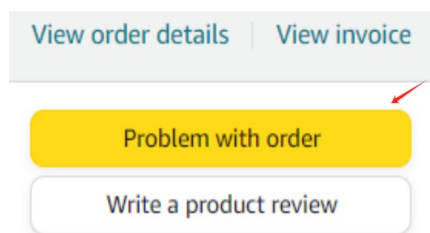

Step 3: From the list of options provided, select "Damaged or Defective Item".

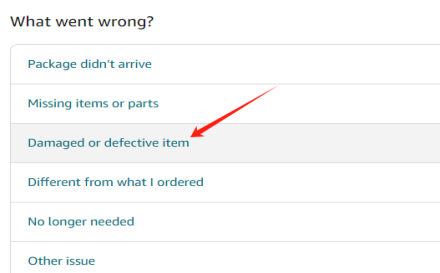

Step 4: Click on the "Contact Seller" button. A text box or form will appear where you can write down your concerns and explain the issue with the item.

