

QUEEN BED









(13 PCS LVL SLATS)

Read these instructions carefully. See hardware and furniture part list for guidance. Be sure all part is complete, before you assemble. Place all wooden furniture part on a clean and flat soft surface to prevent from being scratched. Follow the figure to start assembling.









CAUTION:

1. Do not FULLY-TIGHTEN the nut or bolt untill all nut or nut bolt is ready to assembled.
2. Do not OVER-TIGHTEN the nut or nut bolt to avoid causing damages to the thread.
3. Keep all hardware part out of reach of children.

PART LIST

| NO | DESCRIPTION                                                                                               | QTY   |
|----|-----------------------------------------------------------------------------------------------------------|-------|
| 1  | HEADBOARD                | 1PC   |
| 2  | FOOTBOARD                | 1PC   |
| 3  | SIDE RAIL                | 2PCS  |
| 4  | CENTRE RAIL              | 1PC   |
| 5  | SUPPORT LEG              | 3PCS  |
| 6  | SLAT                     | 13PCS |
| 7  | HEADBOARD LEG (185mm)    | 2PCS  |
| 8  | FOOTBOARD LEG (200mm)    | 2PCS  |
| 9  | BED LEG SUPPORT (METAL)  | 2PCS  |

HARDWARE LIST

| NO | DESCRIPTION                                                                                                | QTY   |
|----|------------------------------------------------------------------------------------------------------------|-------|
| A  | JCBB M8 X 35MM          | 8PCS  |
| B  | JCBC M6 X 25MM          | 8PCS  |
| C  | JCBC M6 X 35MM          | 6PCS  |
| D  | SPRING WASHER 5/16"     | 22PCS |
| E  | FLAT WASHER 5/16"       | 16PCS |
| F  | FLAT WASHER 1/4"        | 6PCS  |
| G  | CSK M4 X 30MM           | 33PCS |
| H  | ALLEN KEY M4 with ball  | 1PC   |
| I  | ALLEN KEY M5            | 1PC   |

STEP 1

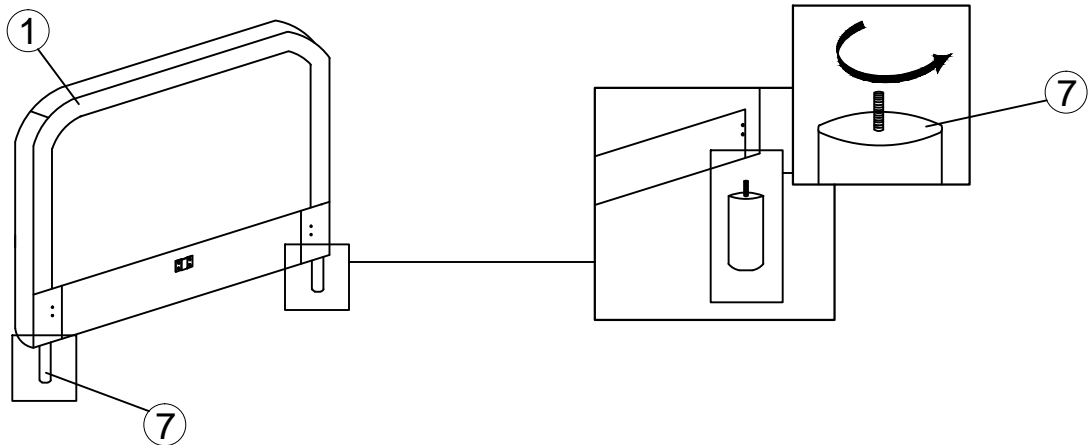

STEP 2

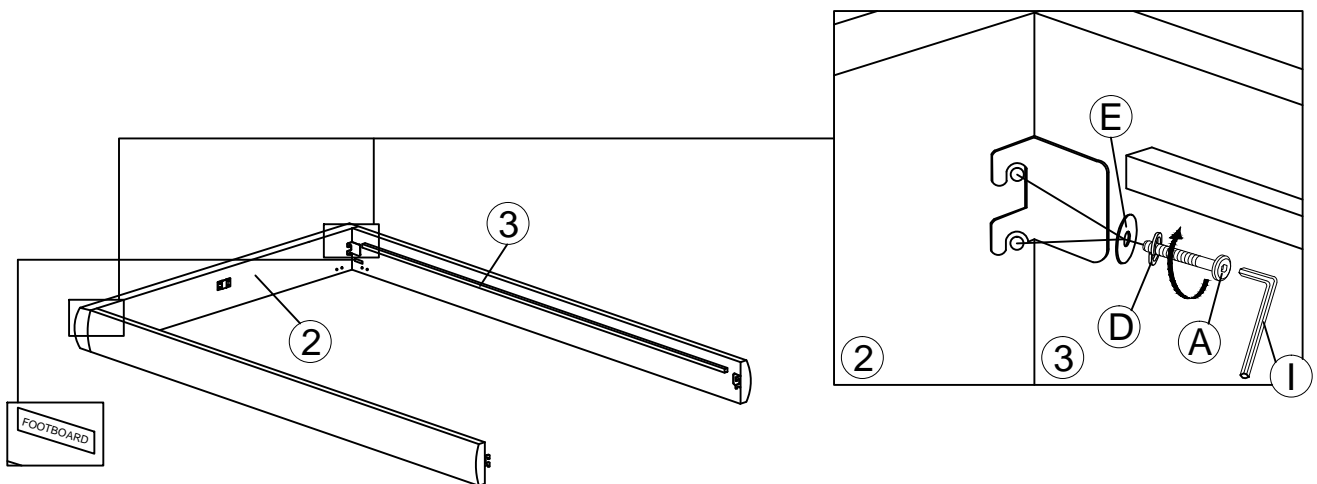

STEP 3

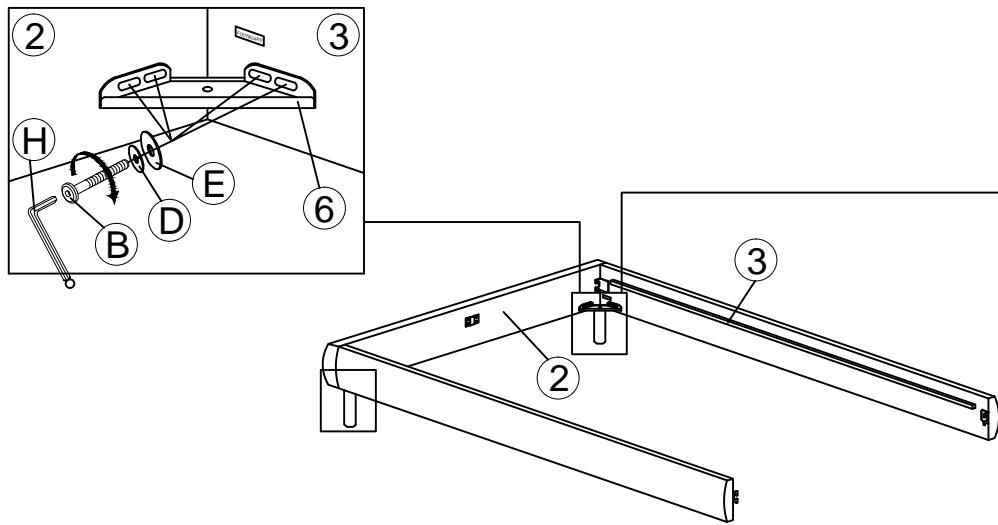

STEP 4

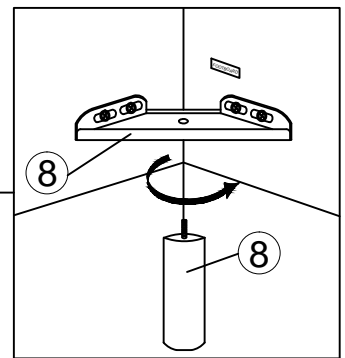

STEP 5

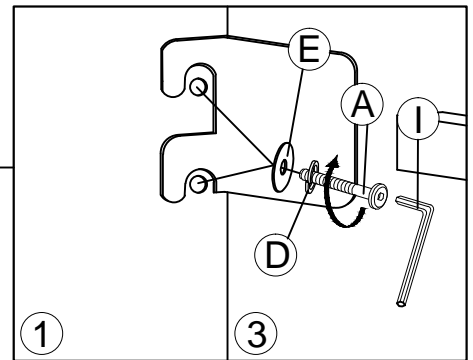
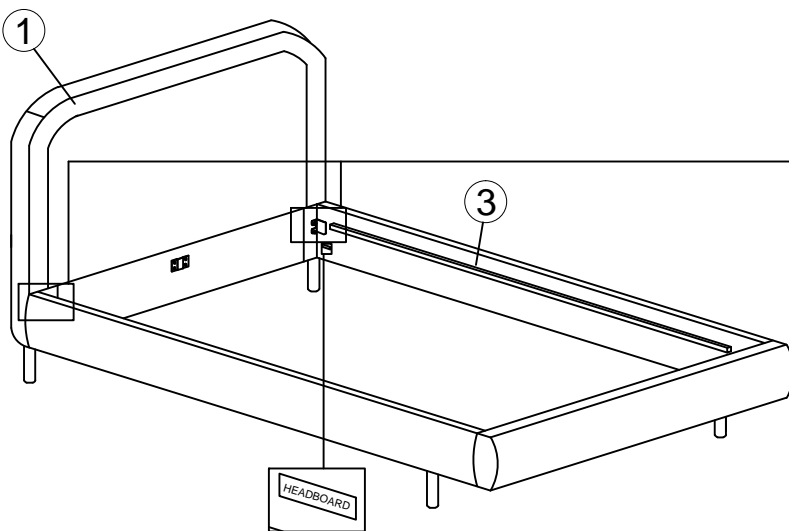

STEP 6

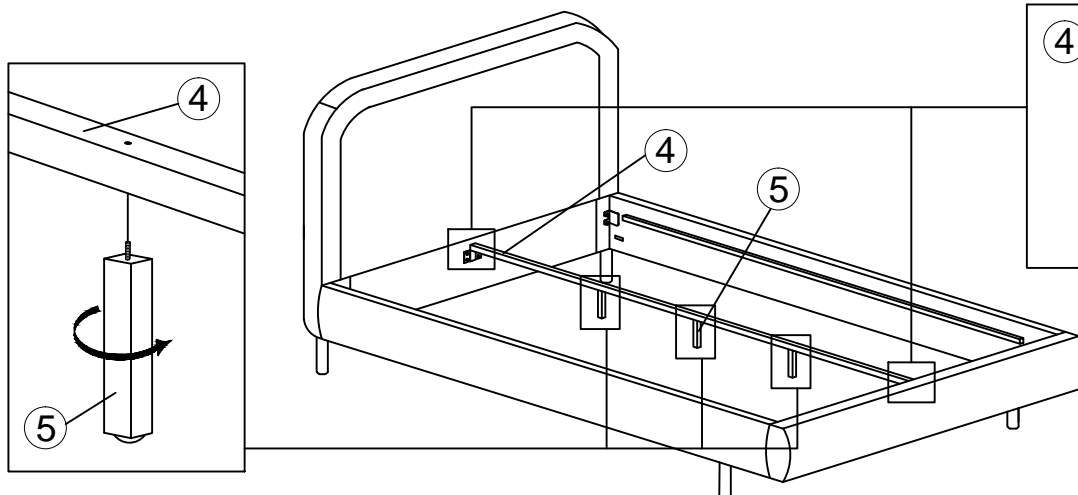

STEP 7

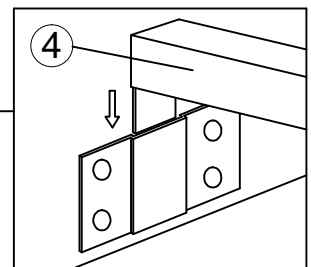

STEP 8

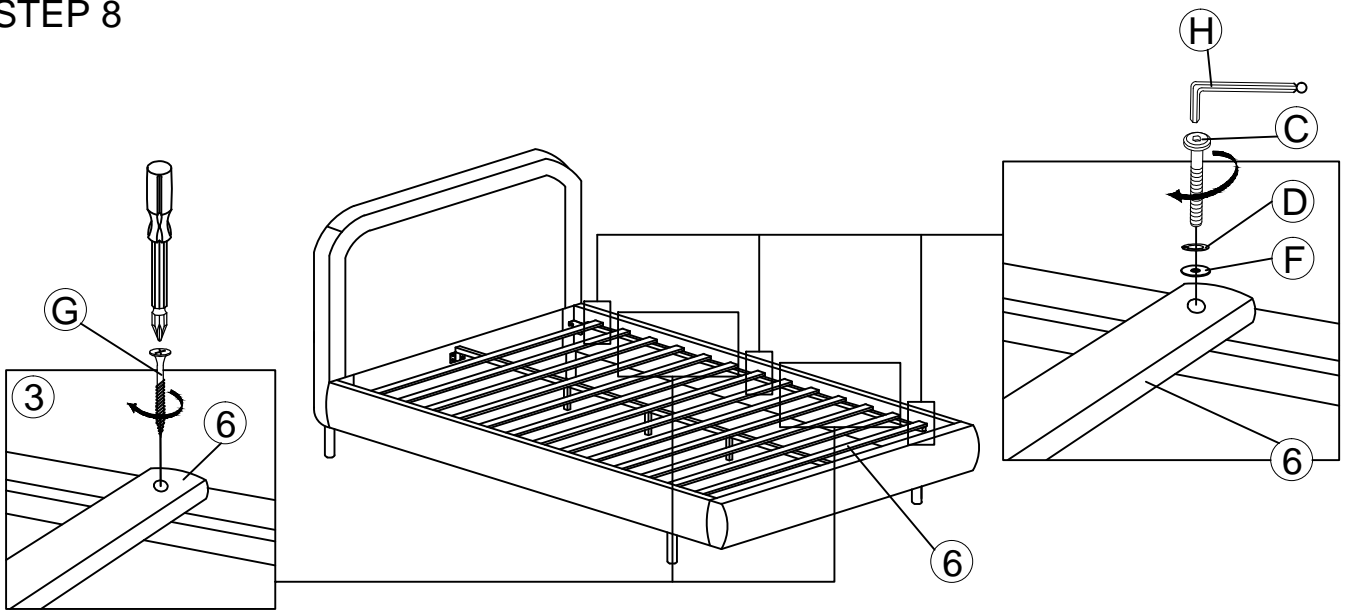

STEP 9

