

ASSEMBLY INSTRUCTION

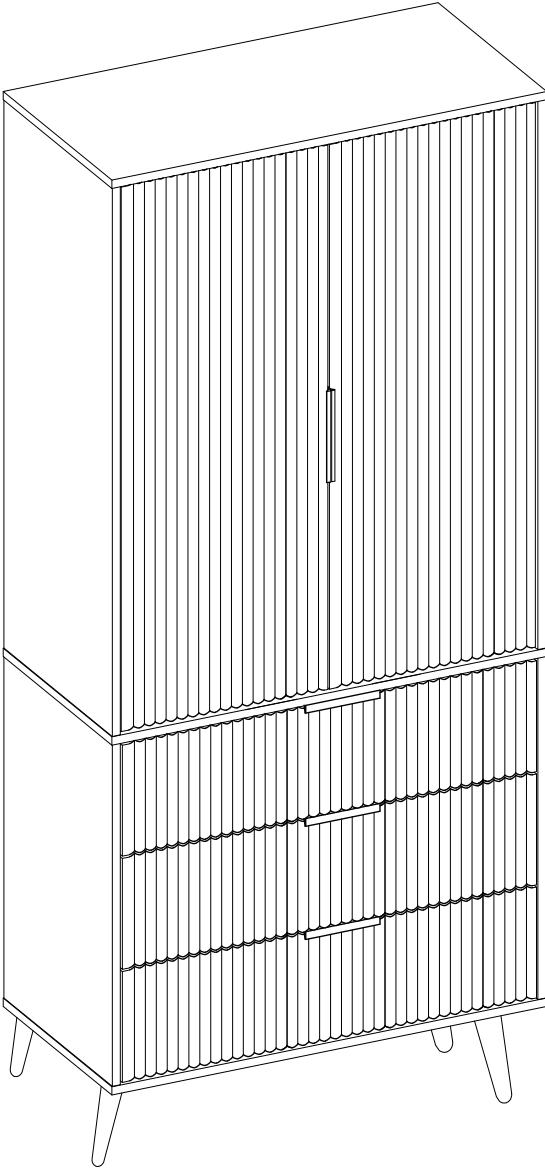

Notes:

1. ASSEMBLY PREPARATION AND TIPS FOR ASSEMBLY



- 1). Remove all packaging materials, staples and packing straps from the carton.
- 2). Refer to Parts List and Hardware List, and ensure parts and hardware are correct before assembly.
Contact customer service for missing parts.
- 3). Place all wooden parts on a clean, flat and soft surface (e.g. carpet or rug) to prevent scratch and damage to parts.
- 4). Allow ample room for assembly and assemble the product near where the product will be placed.
- 5). During assembly, do not over-tighten any fittings as this may cause damage.
- 6). Always place the product on a flat, level surface.



2. CARE AND MAINTENANCE

- 1). KEEP ALL HARDWARE PARTS OUT OF REACH OF CHILDREN.
- 2). Wipe clean with a soft, dry cloth; avoid the use of harsh chemicals or household cleaners as they may damage the exterior finish of the furniture.
- 3). Hardware may loosen over time. Periodically, check that all connections are tight; re-tighten as necessary.

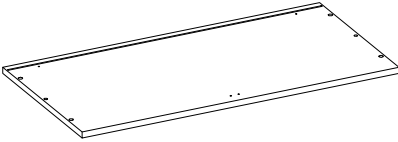
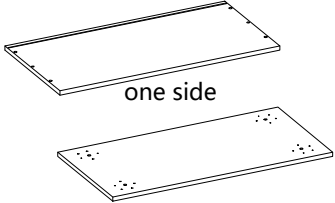
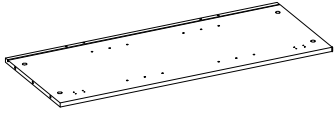
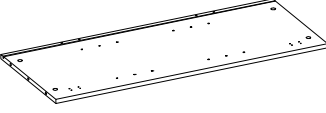
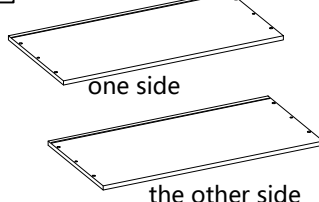
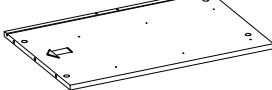
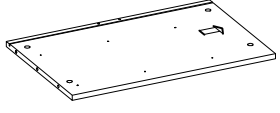
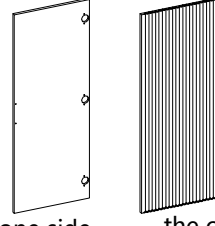
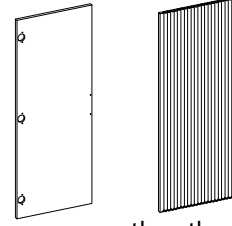
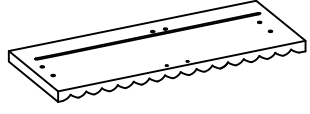
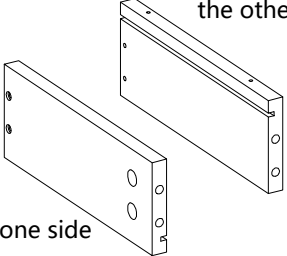
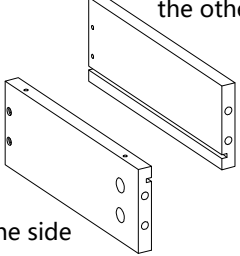
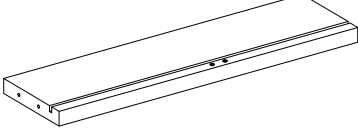
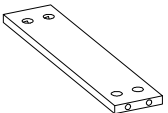
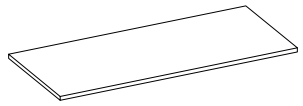
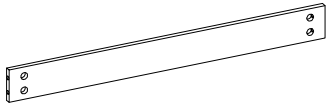
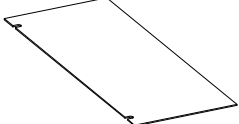
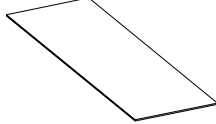
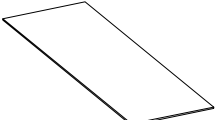
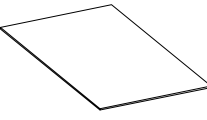
3. TIPS TO PROTECT & CARE FOR YOUR FURNITURE

- 1). Avoid placing your furniture in direct sunlight, as sunlight causes fading.
- 2). Use a protective pad when writing on the furniture surface.
- 3). Use cutting boards and trivets for food preparation in order to avoid damaging the top for the unit.

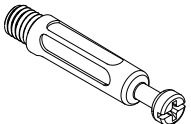
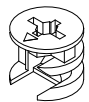
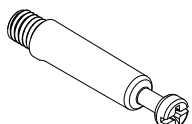
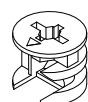
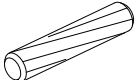
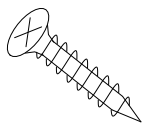
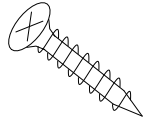
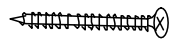
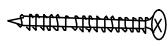
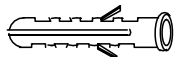
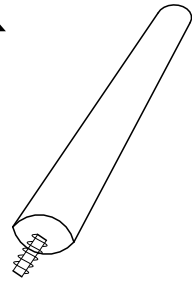
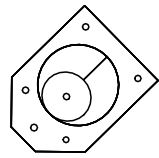
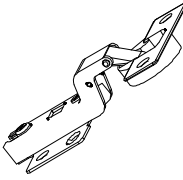
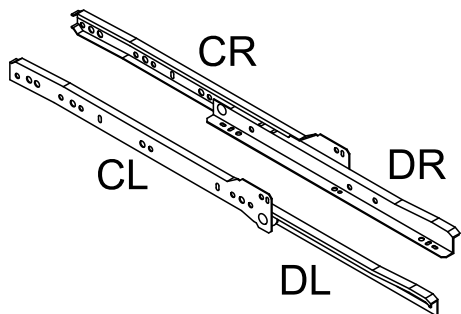
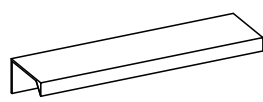
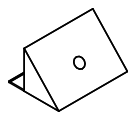
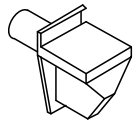
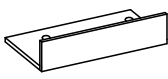
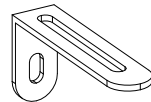
<p>1</p>  <p>800*400*15 1PC</p>	<p>2</p>  <p>800*400*15 1PC</p>	<p>3</p>  <p>989*399*15 1PC</p>
<p>4</p>  <p>989*399*15 1PC</p>	<p>5</p>  <p>800*400*15 1PC</p>	<p>6</p>  <p>616*399*15 1PC</p>
<p>7</p>  <p>616*399*15 1PC</p>	<p>8</p>  <p>982*379*15 1PC</p>	<p>9</p>  <p>982*379*15 1PC</p>
<p>10</p>  <p>200*762*15 3PCS</p>	<p>11</p>  <p>350*150*12 3PCS</p>	<p>12</p>  <p>350*150*12 3PCS</p>
<p>13</p>  <p>719*150*12 3PCS</p>	<p>14</p>  <p>337*72*12 3PCS</p>	<p>15</p>  <p>766*356*12 2PCS</p>
<p>16</p>  <p>768*100*12 3PCS</p>	<p>17</p>  <p>331*778*3 1PC</p>	<p>18</p>  <p>331*778*3 2PCS</p>
<p>19</p>  <p>311.5*778*3 2PCS</p>	<p>20</p>  <p>729*347*3 3PCS</p>	<p>21</p>  <p>L=766mm 3PCS</p>

<p>A</p>  <p>16PCS</p>	<p>B</p>  <p>16PCS</p>	<p>C</p>  <p>36PCS</p>	<p>D</p>  <p>36PCS</p>
<p>E</p>  <p>Ø8*30mm 8PCS</p>	<p>F</p>  <p>Ø3.5*12mm 34PCS</p>	<p>G</p>  <p>Ø3.5*14mm 80PCS</p>	<p>H</p>  <p>Ø3.5*30mm 12PCS</p>
<p>I</p>  <p>Ø3.5*40mm 2PCS</p>	<p>J</p>  <p>2PCS</p>	<p>K</p>  <p>4PCS</p>	<p>L</p>  <p>4CS</p>
<p>M</p>  <p>6PCS</p>	<p>N</p>  <p>3PCS</p>		<p>O</p>  <p>5PCS</p>
<p>P</p>  <p>20PCS</p>	<p>Q</p>  <p>8PCS</p>	<p>R</p>  <p>1PC</p>	<p>S</p>  <p>2PCS</p>
<p>T</p>  <p>52PCS</p>			

Instructions For Fastening CAM-BOLT and CAM-LOCK

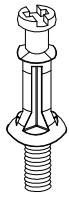

CAM-BOLT

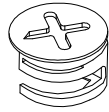

CAM-LOCK

Tools Required

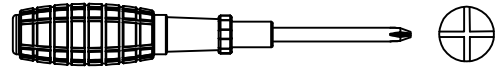

INSERTING AND TIGHTENING CAM-BOLT

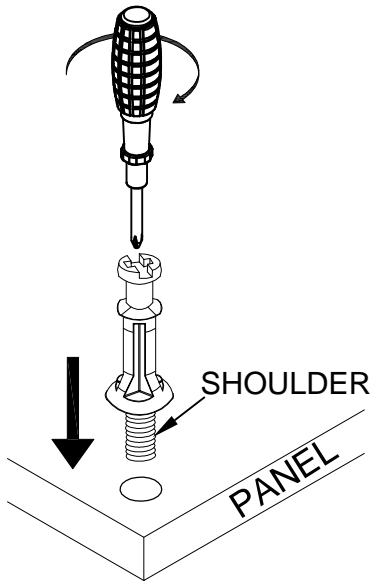

Place Cam-bolt on pre-drilled hole and screw in vertically

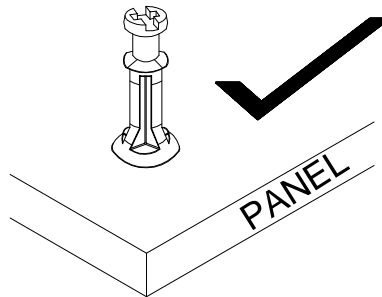

Shoulder is flushed (on the same level) with the panel.

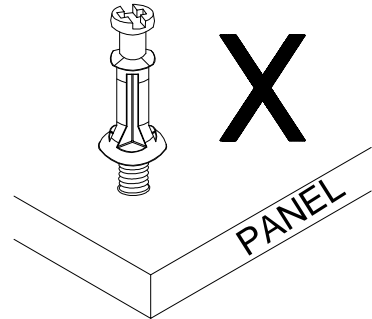

Shoulder is above the panel.

Place Cam-bolt on the designated pre-drilled holes on the panel. Use a Phillips Screwdriver to screw-in Cam-bolt vertically until shoulder is flushed (on the same level) with panel.

INSERTING CAM-LOCK

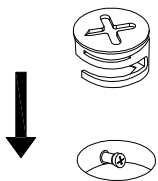

Insert Cam-lock with arrow align to Cam-bolt head

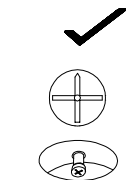

CORRECT

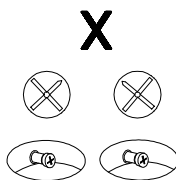

WRONG

Align the arrow on the Cam-lock to the Cam-bolt head and insert the Cam-lock. Ensure Cam-lock is fully inserted.

TIGHTENING CAM-LOCK

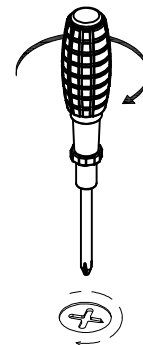

Use a Flat-head Screwdriver to turn Camlock clockwise so it locks onto the head of the Cam-bolt. Turn until it is snug (about 3/4ths of a turn) -- over-tightening could damage Cam-lock or/and Cam-bolt.

N

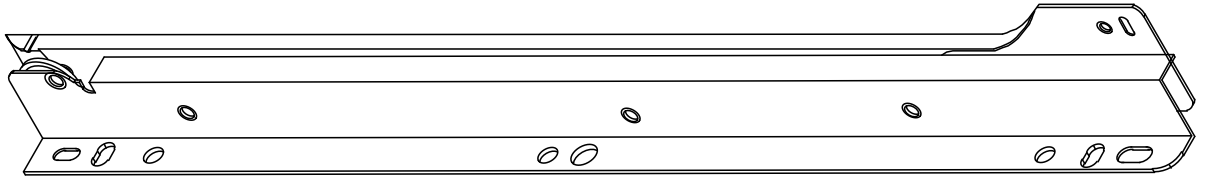

CR

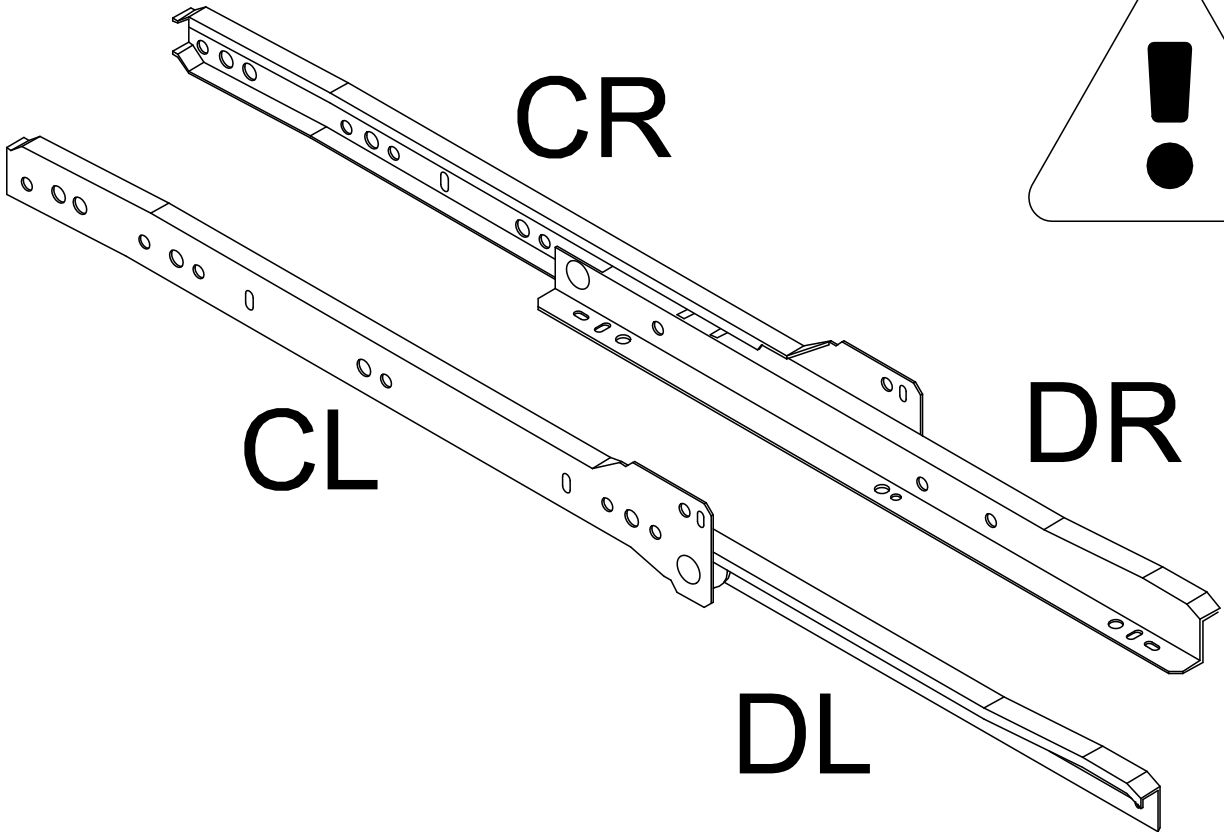

CL

DR

DL

STEP 1

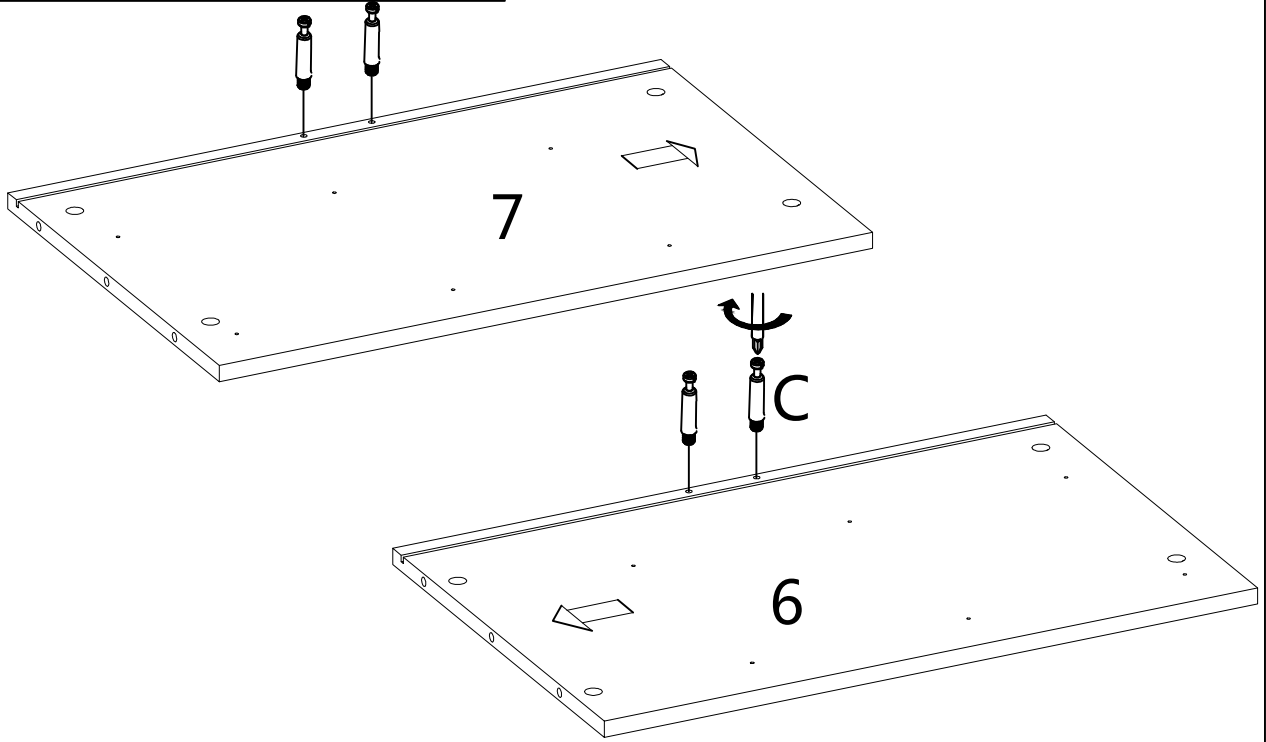
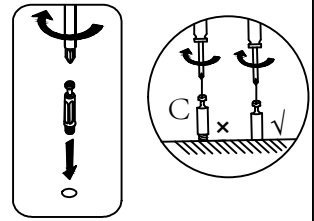
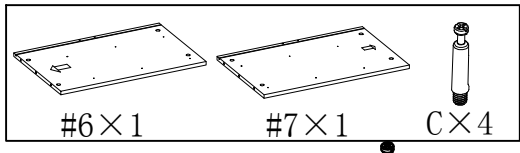

STEP 2

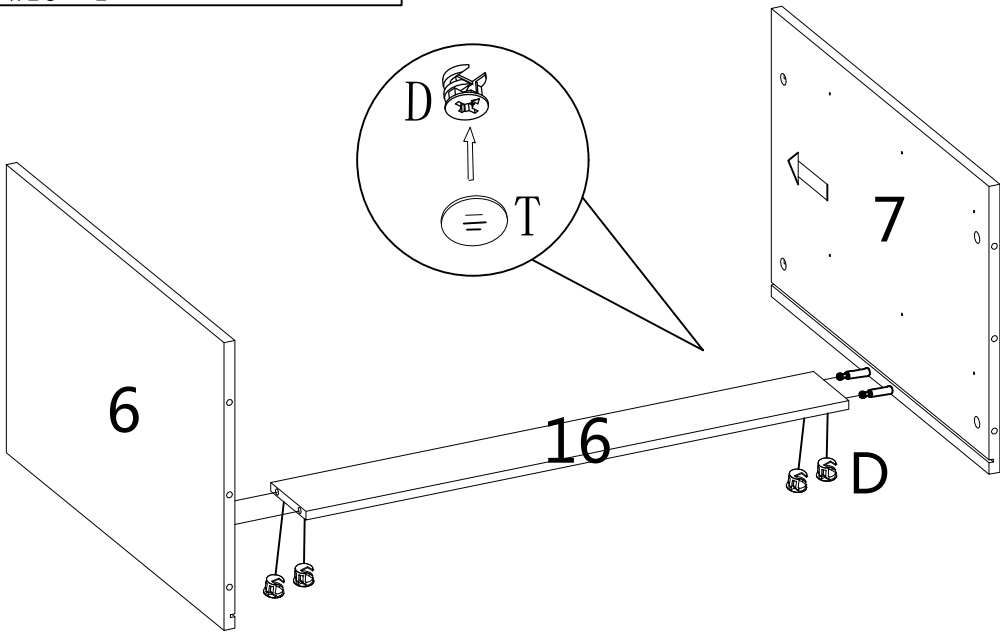
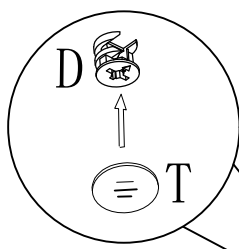
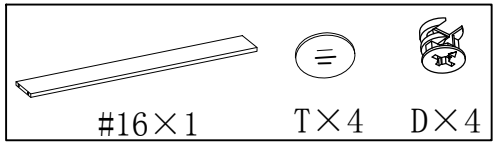

STEP 3

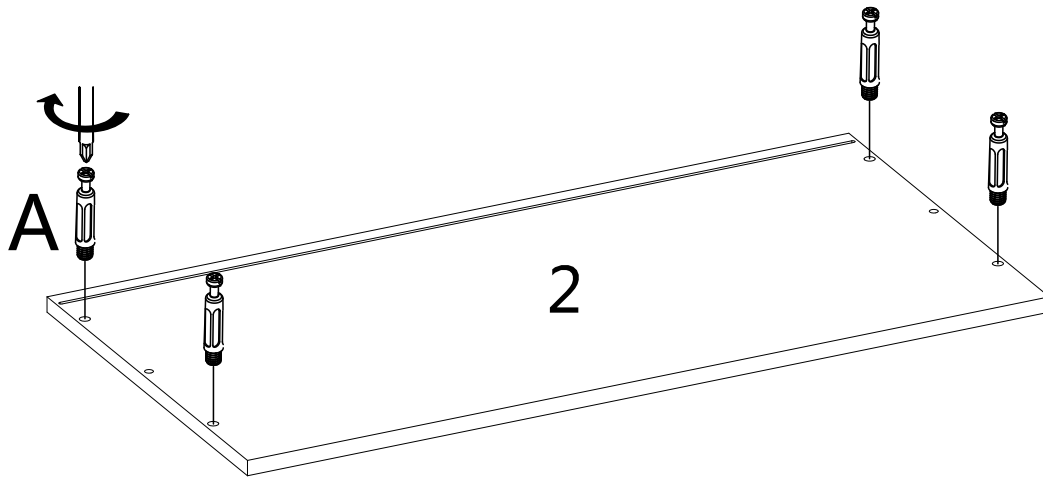
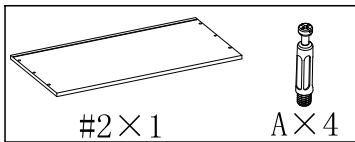

STEP 4

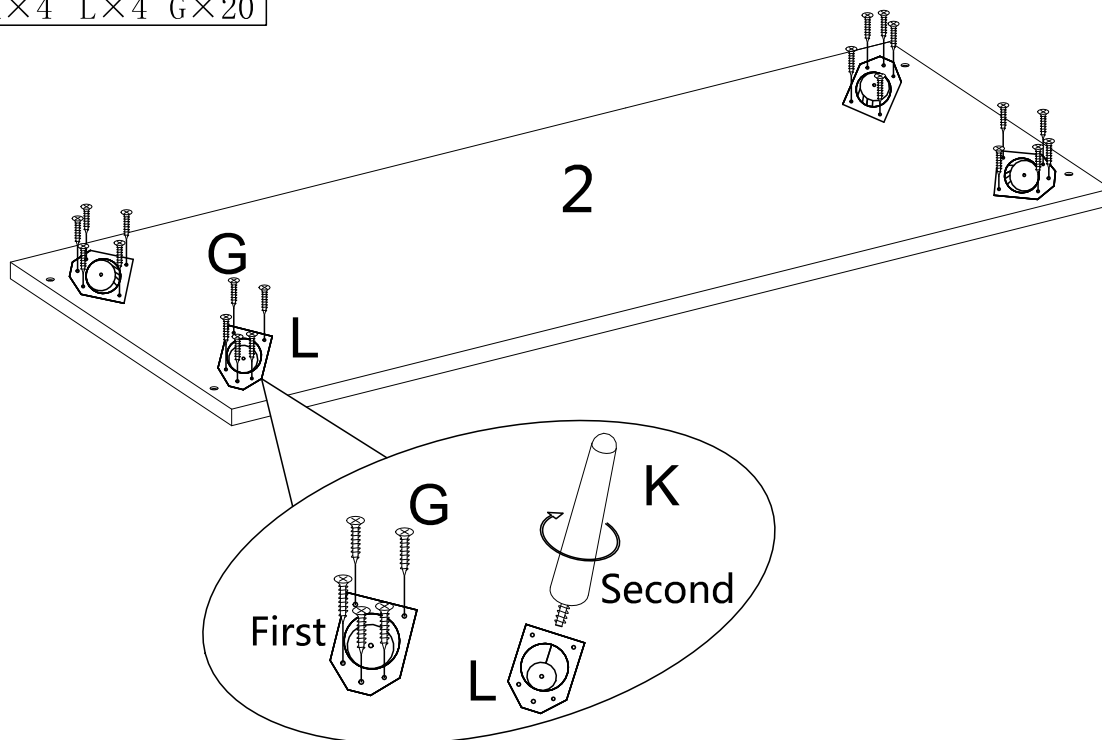
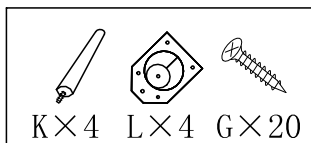

STEP 5

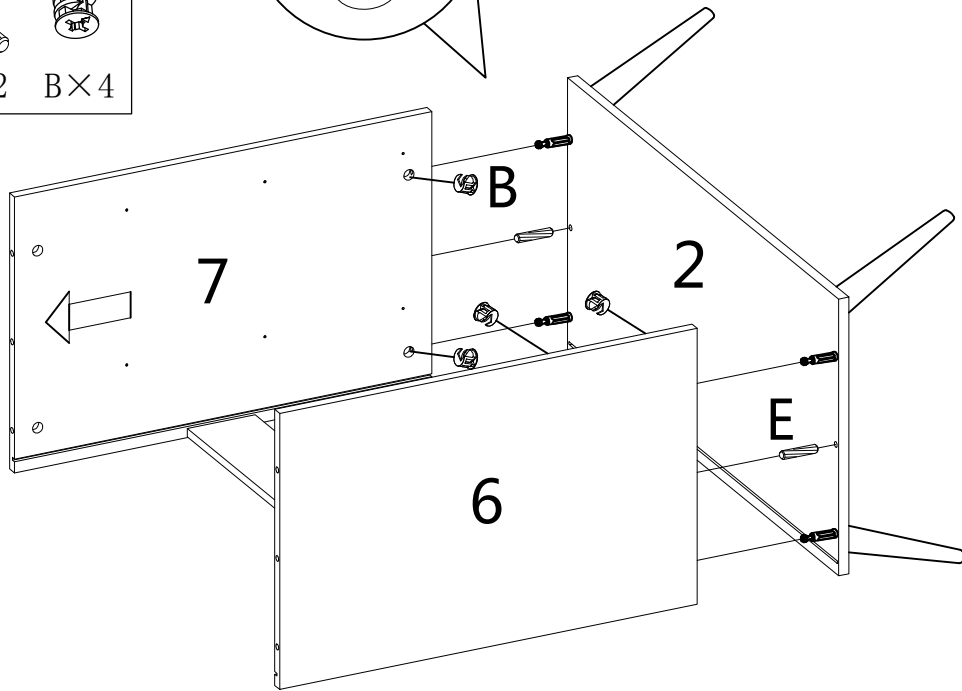
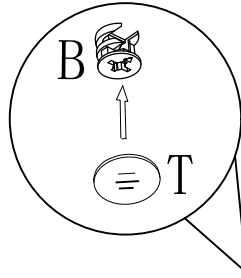
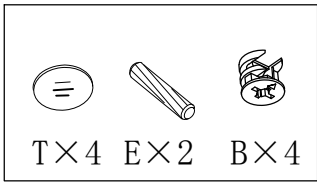

STEP 6

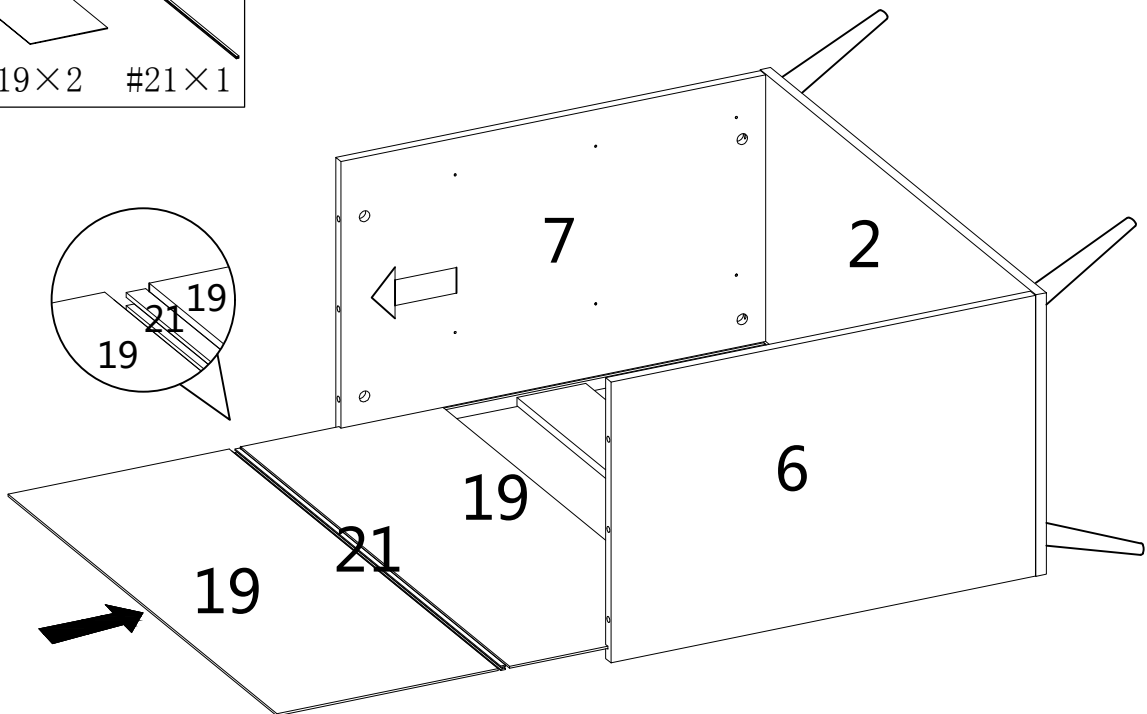
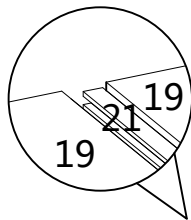
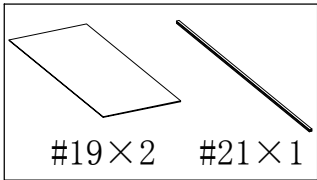

STEP 7

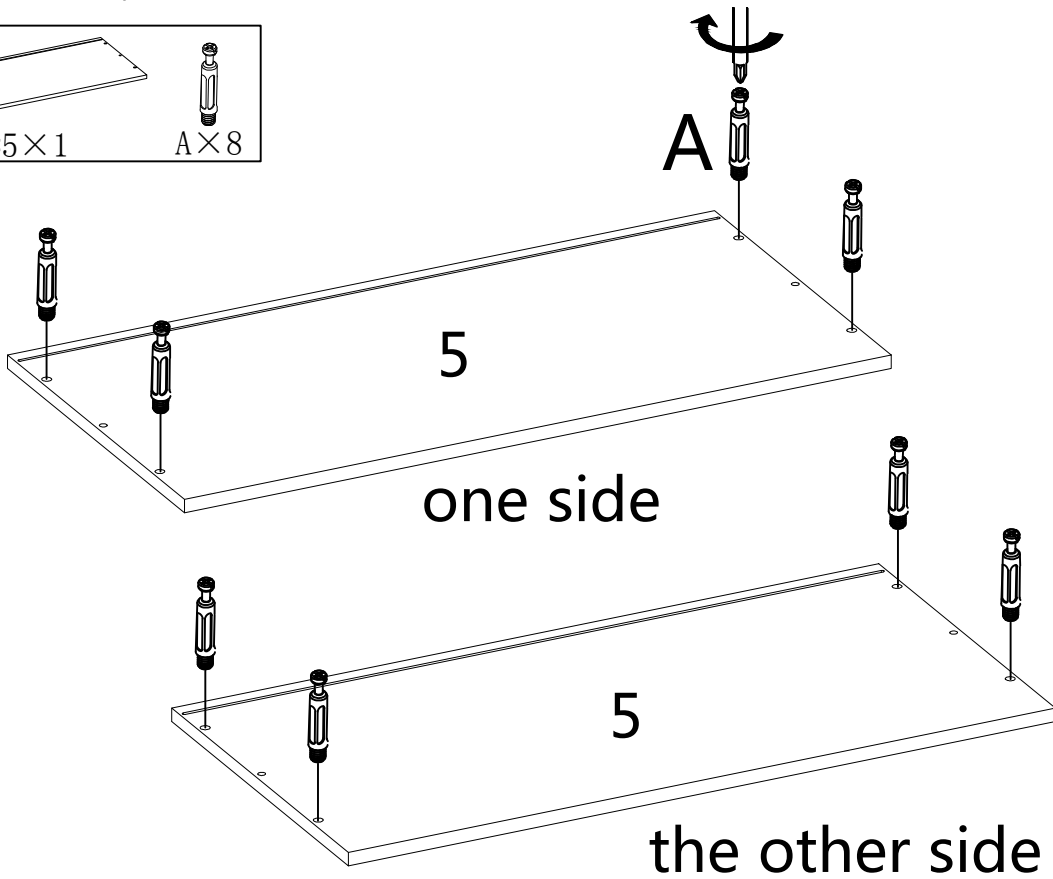
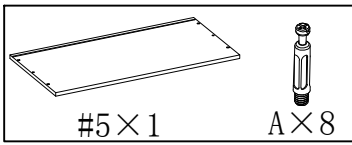

STEP 8

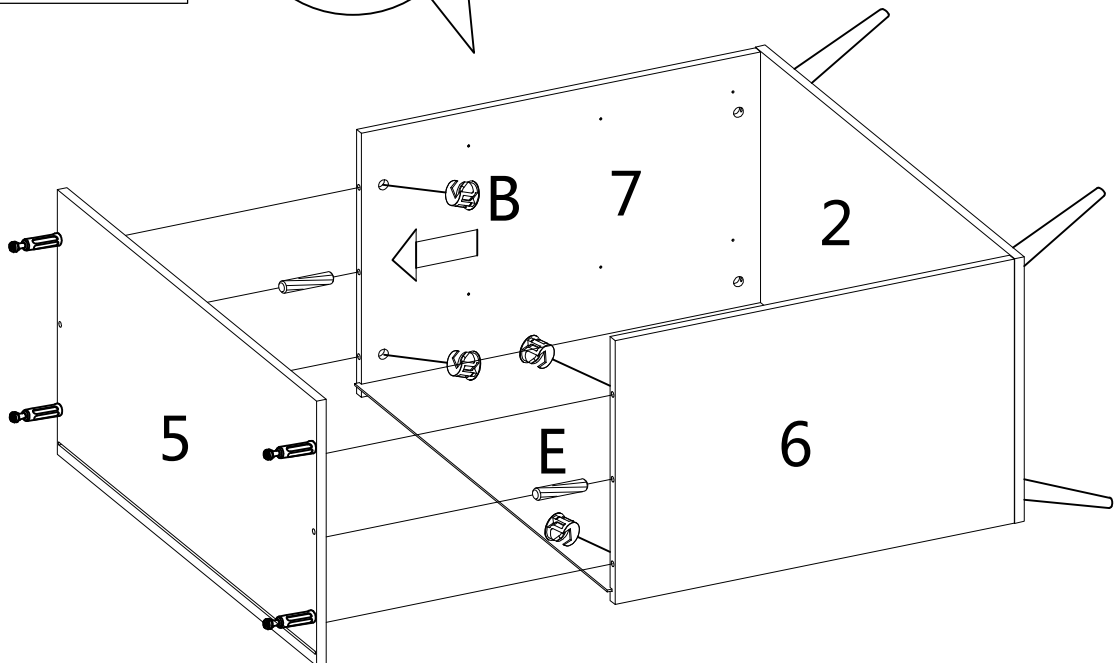
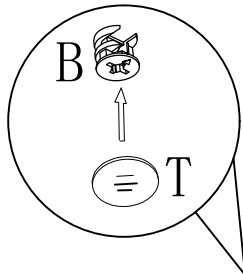
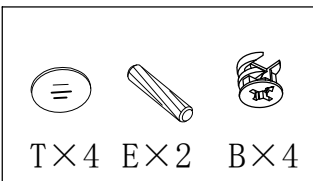

STEP 9

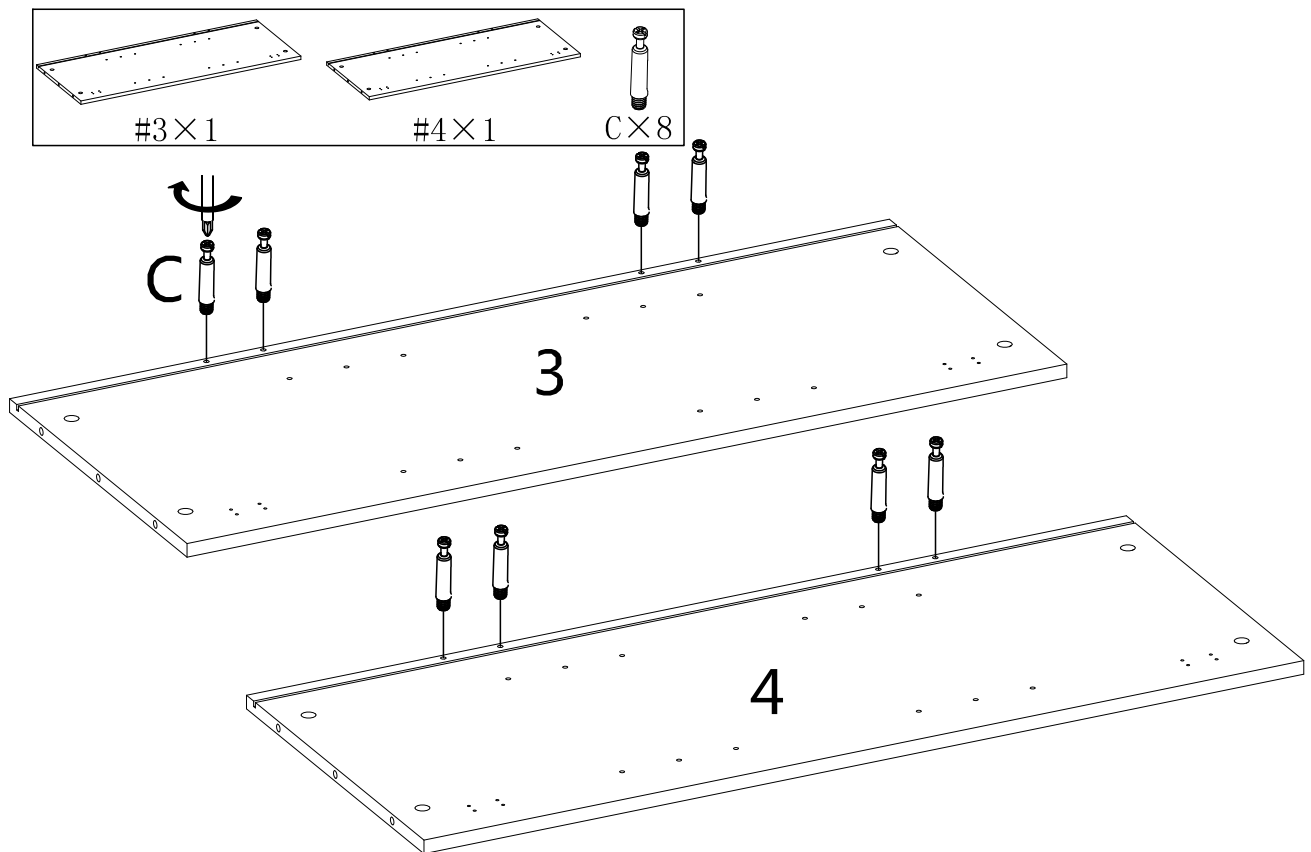

STEP 10

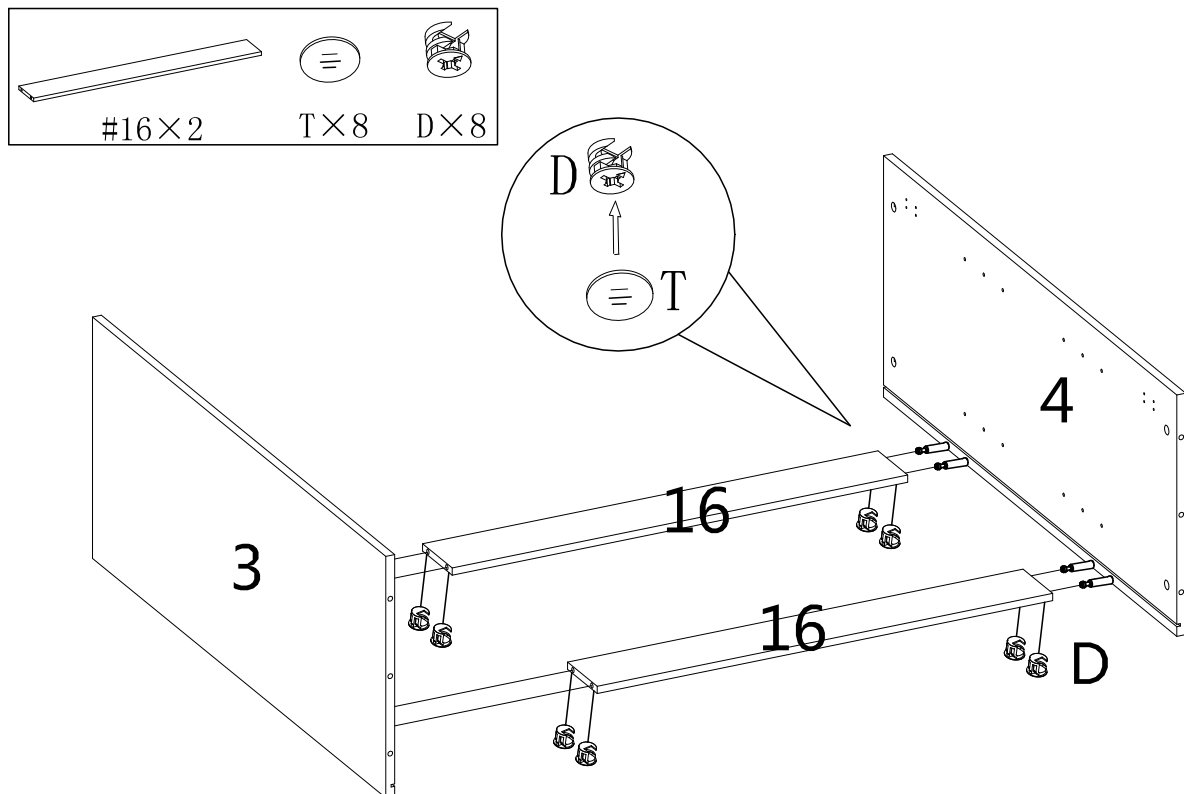

STEP 11

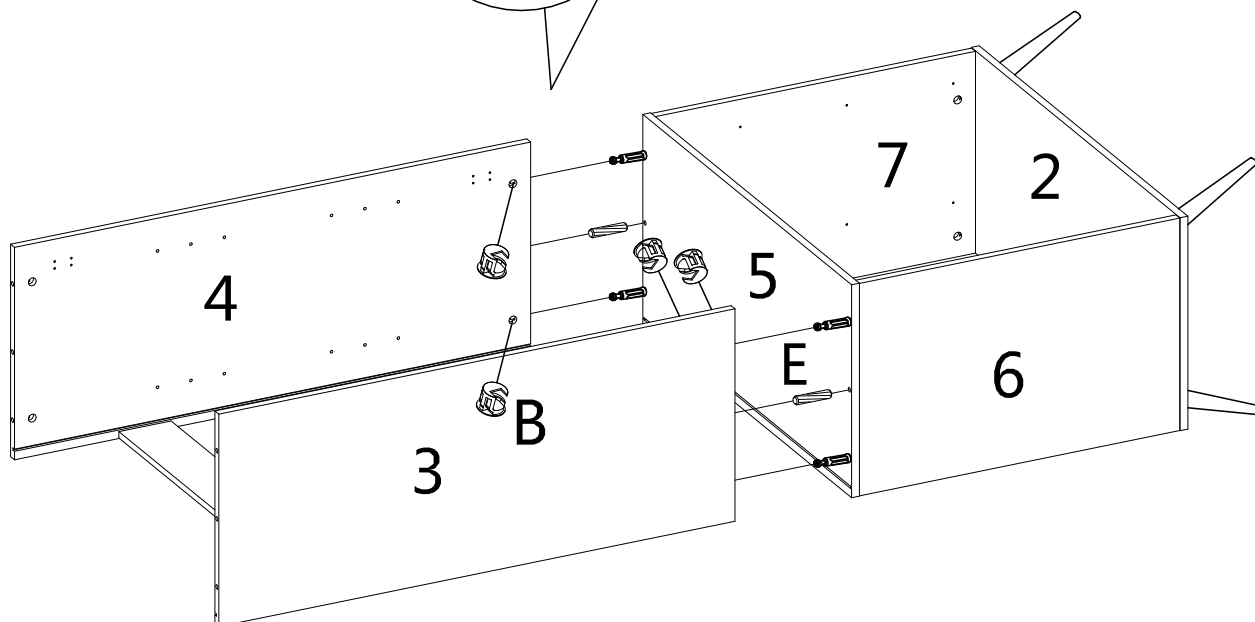
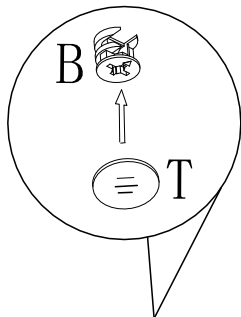
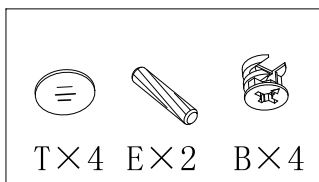

STEP 12

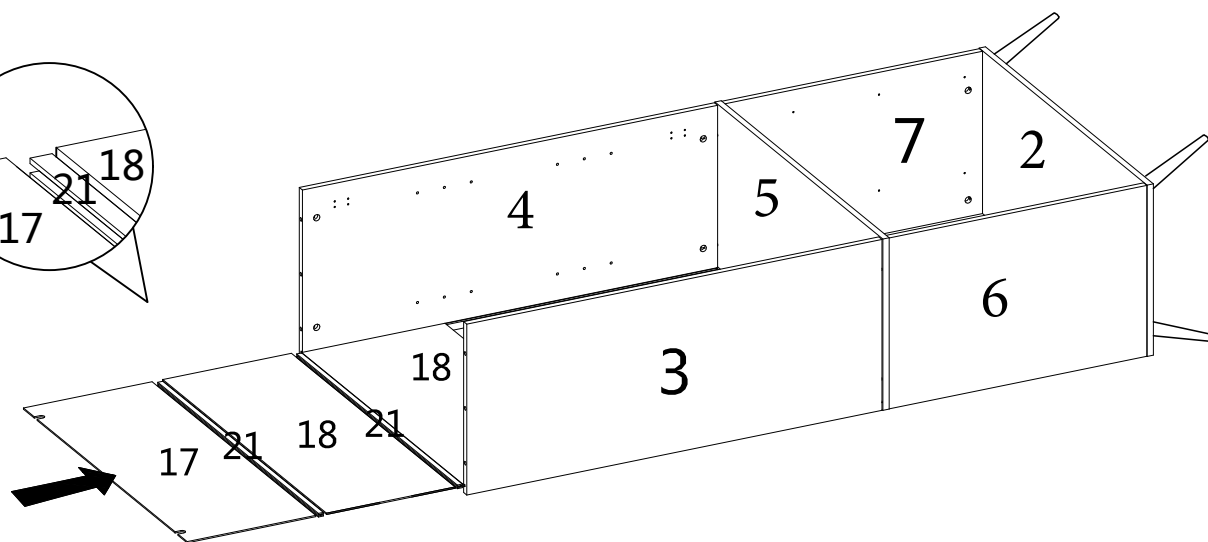
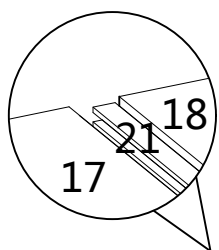
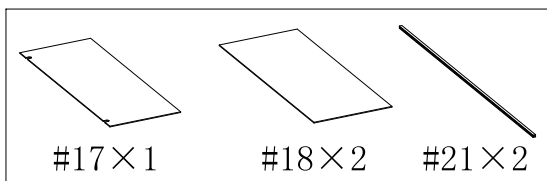

STEP 13

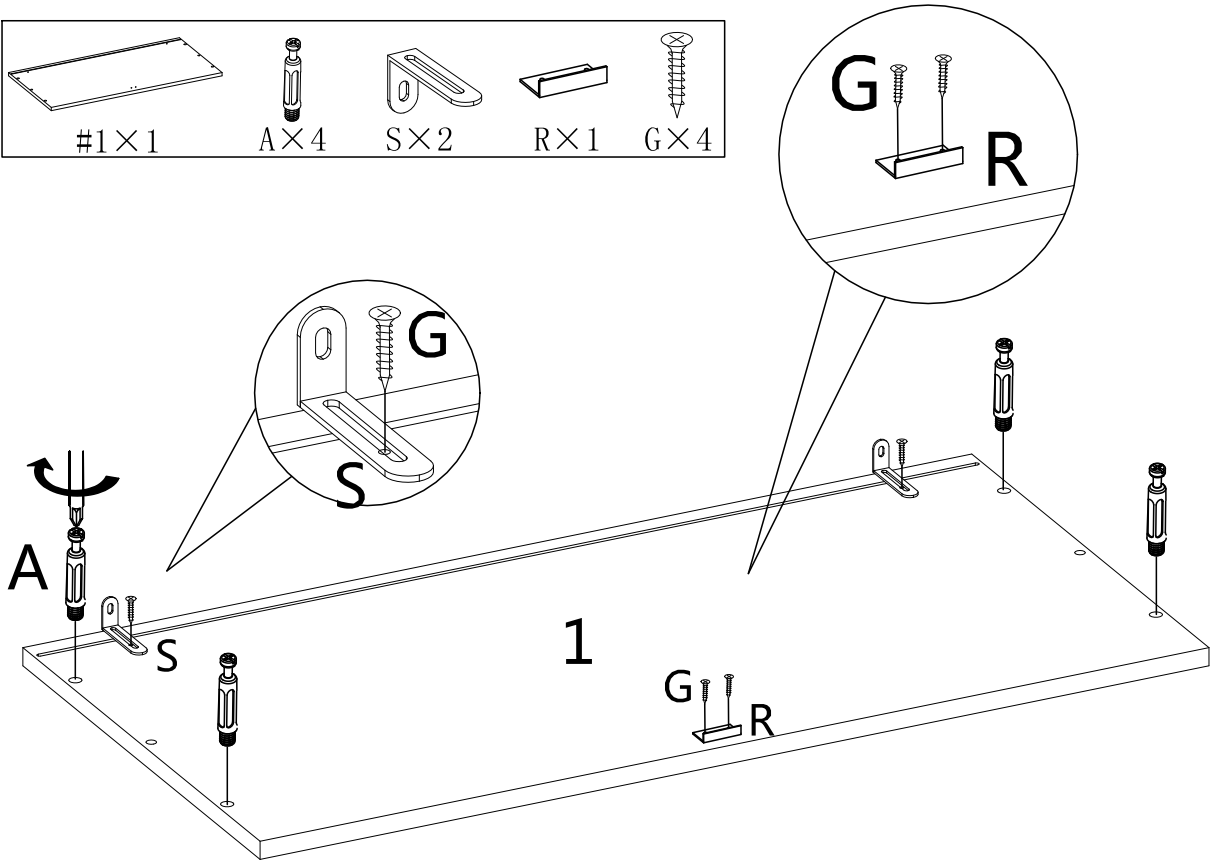
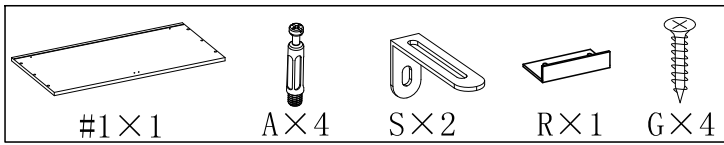

STEP 14

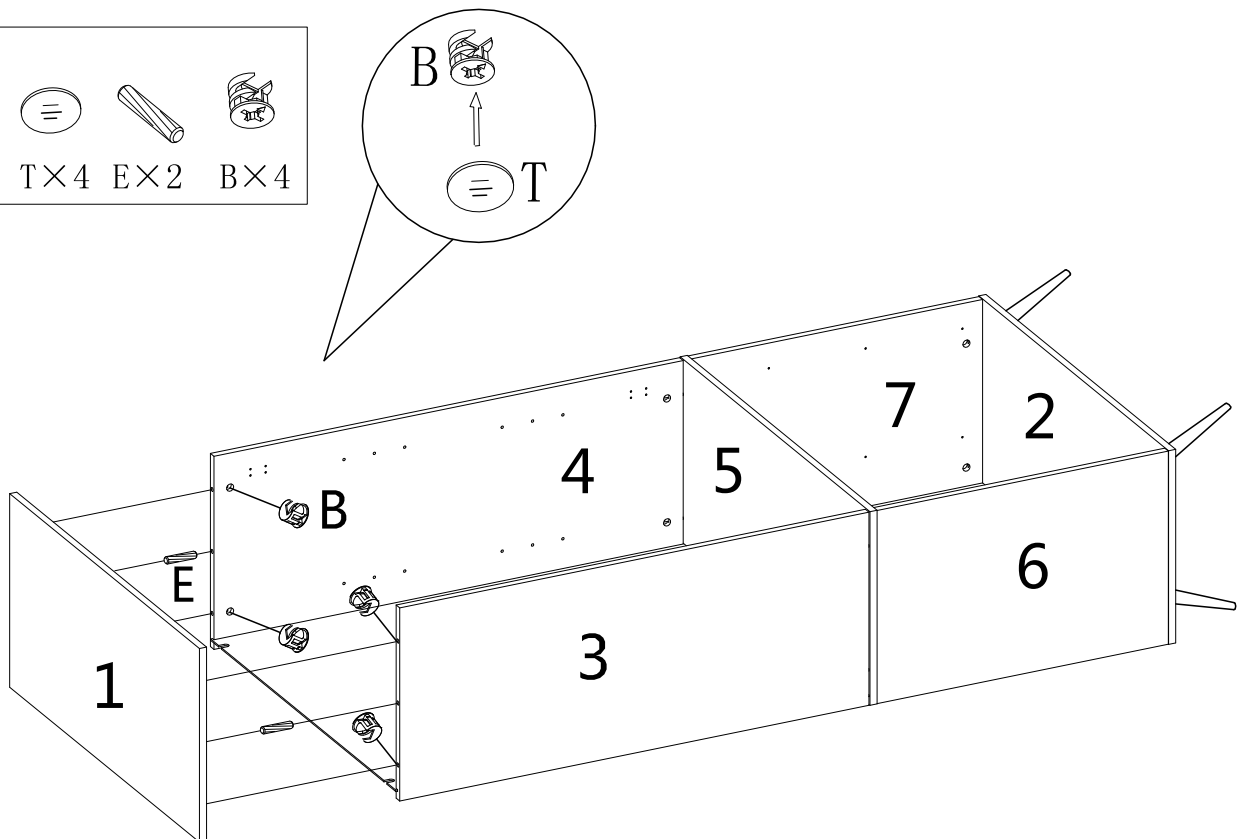
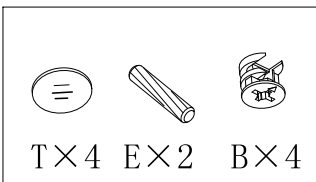

STEP 15

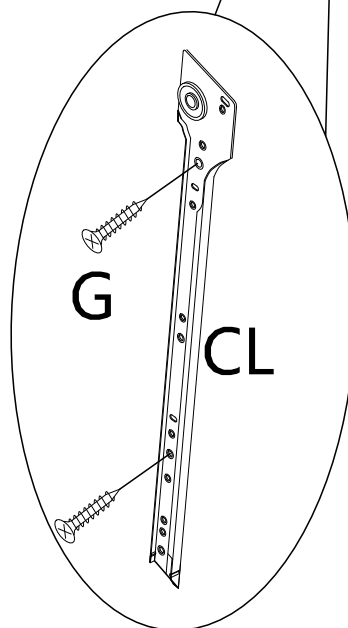
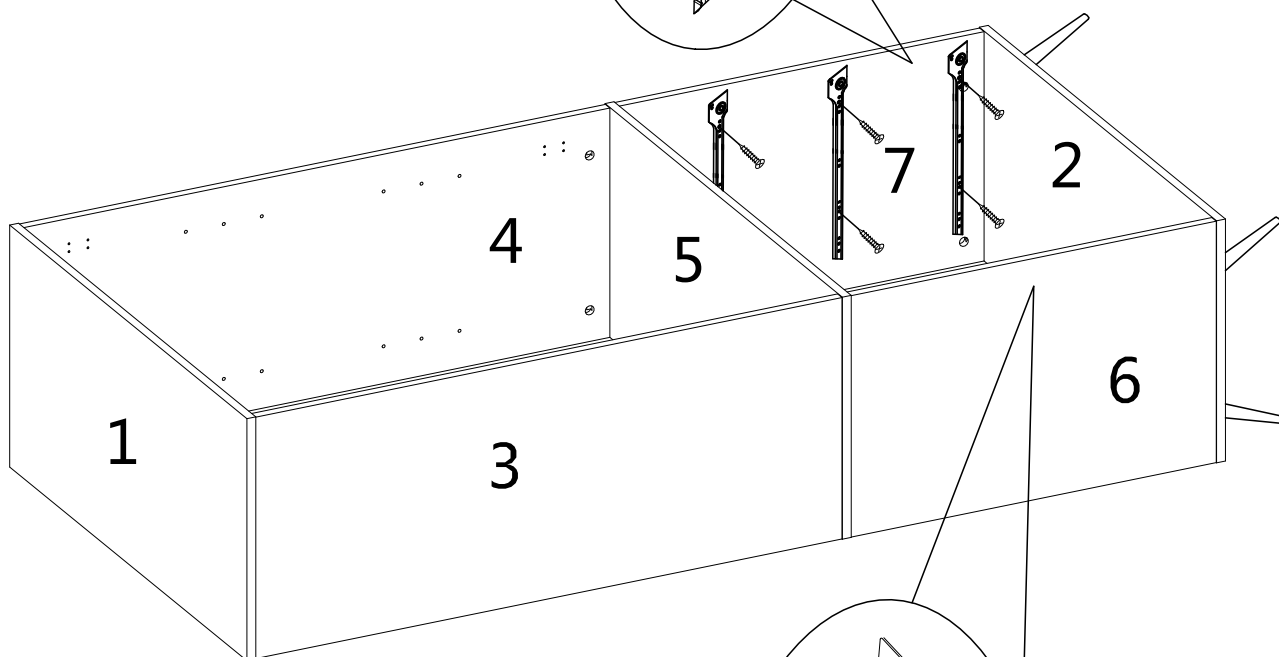
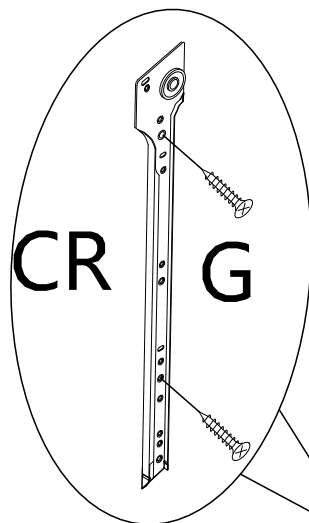
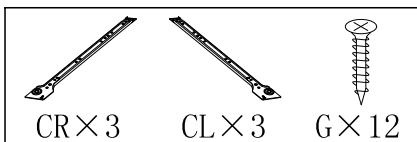

STEP 16

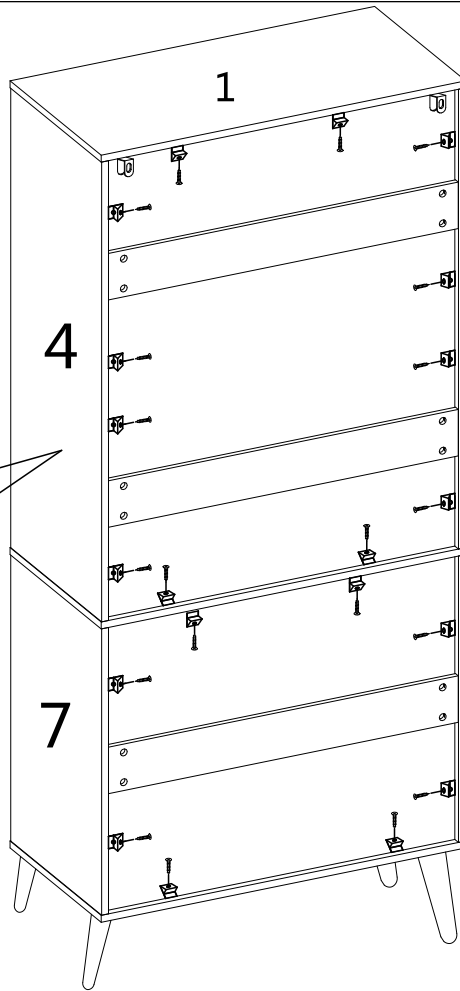
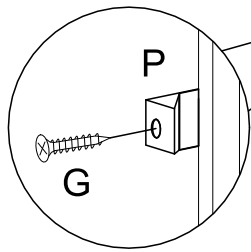
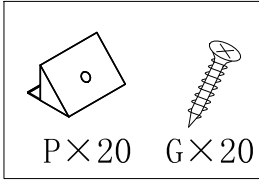

STEP 17

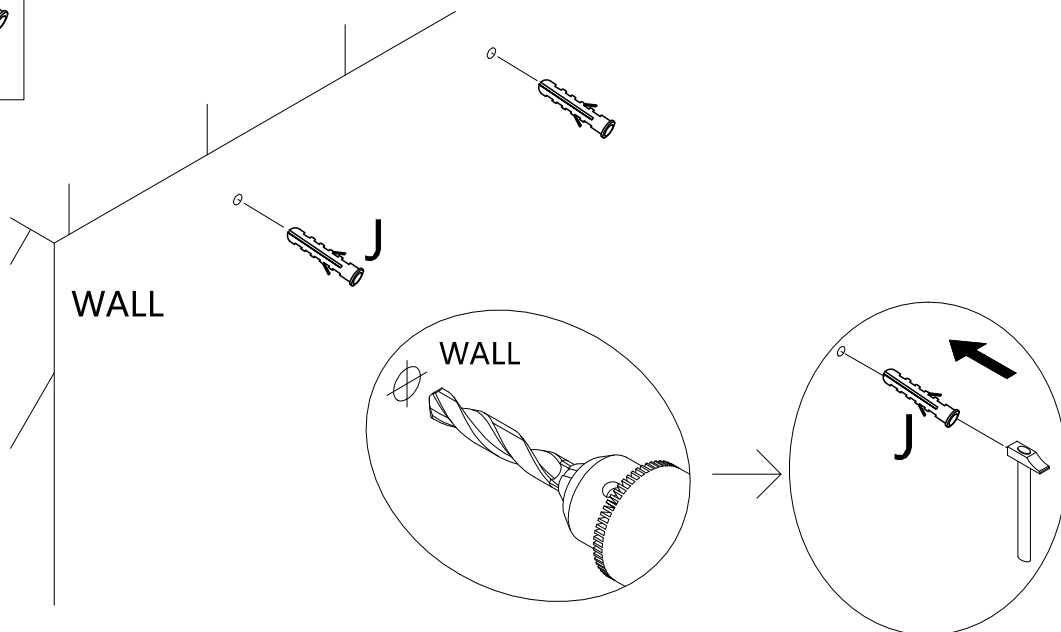

STEP 18

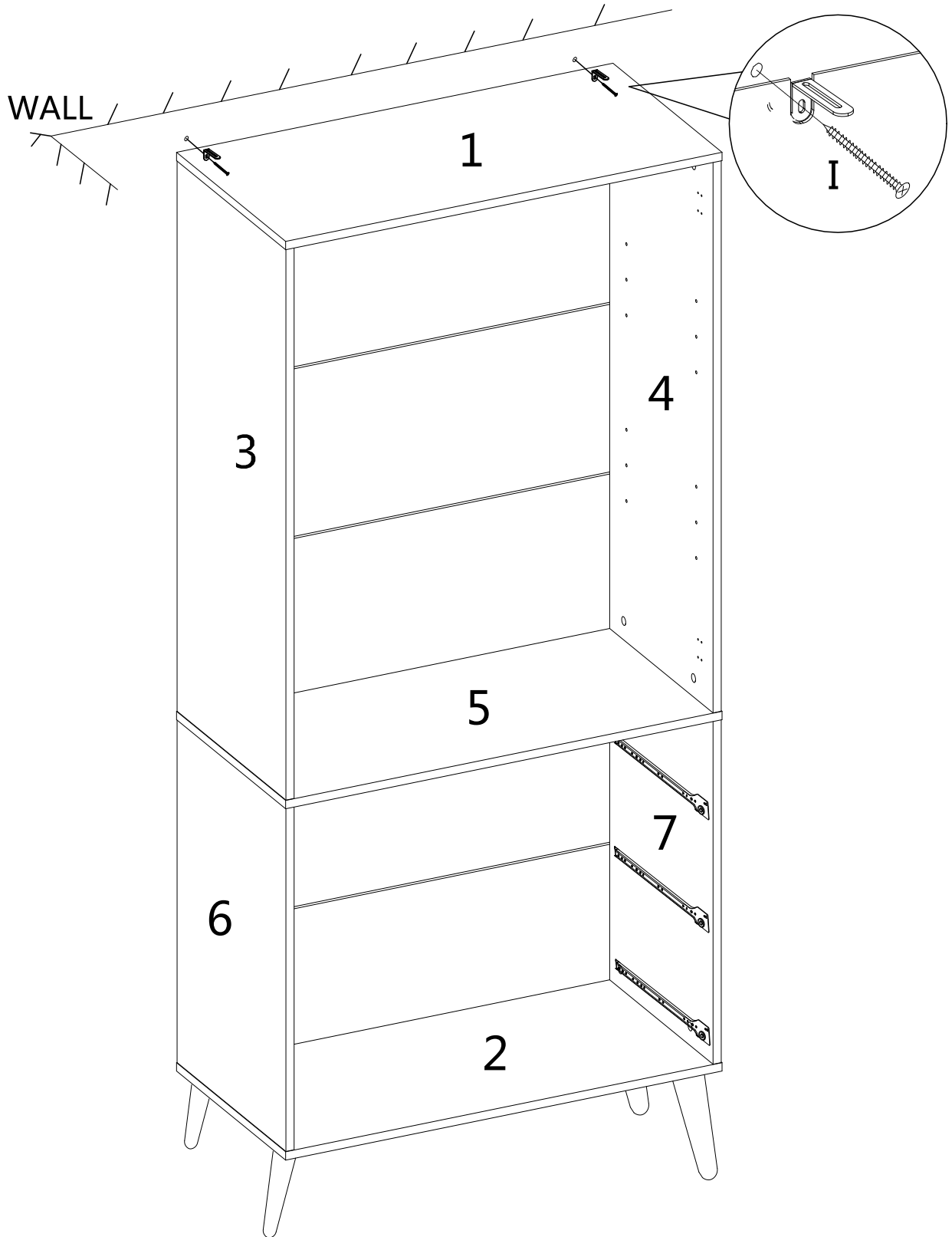
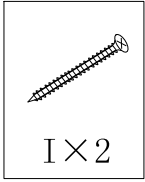

STEP 19

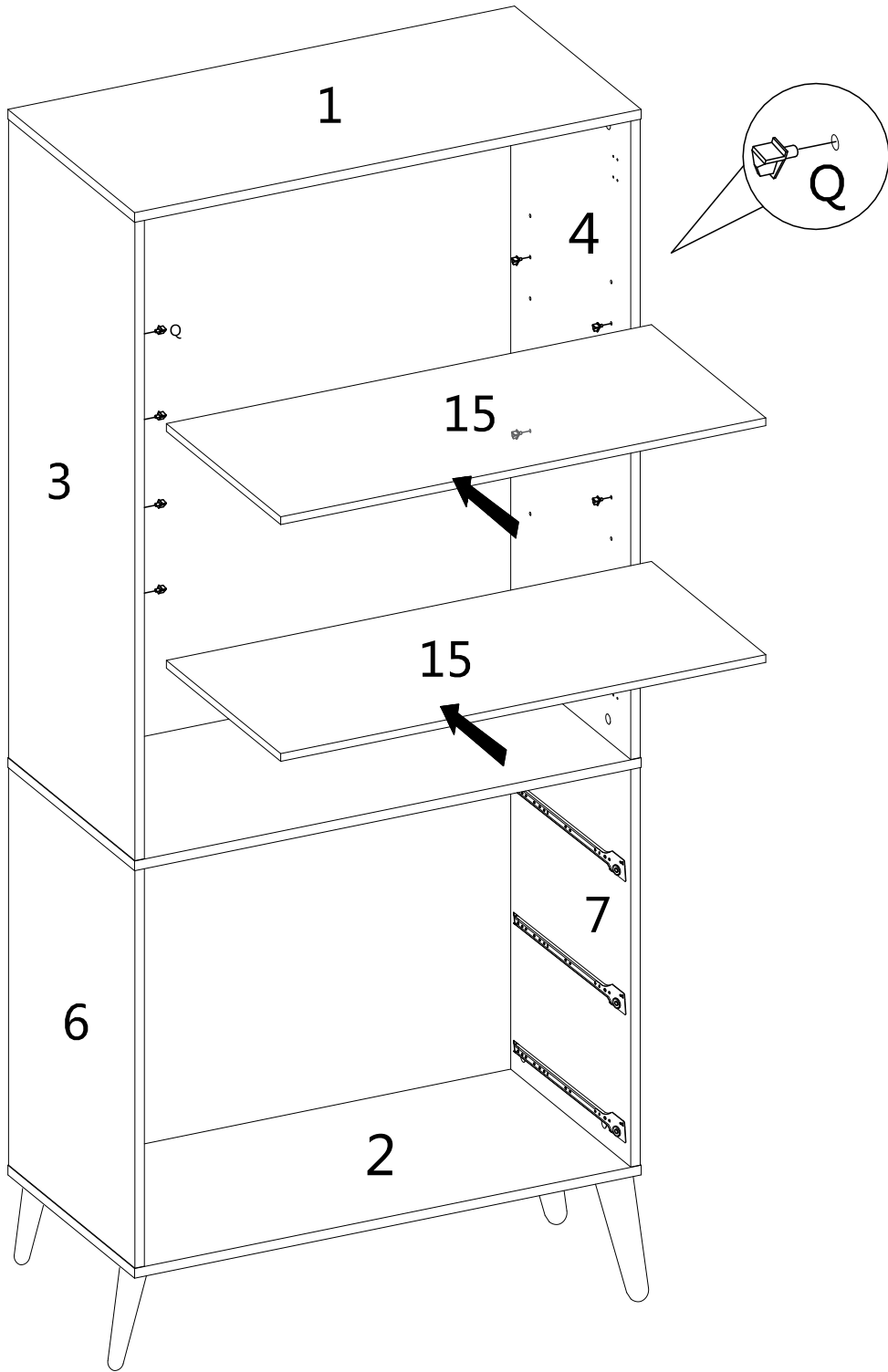
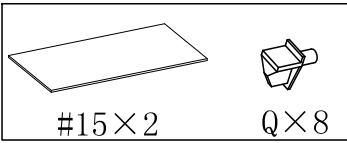

STEP 20

X3

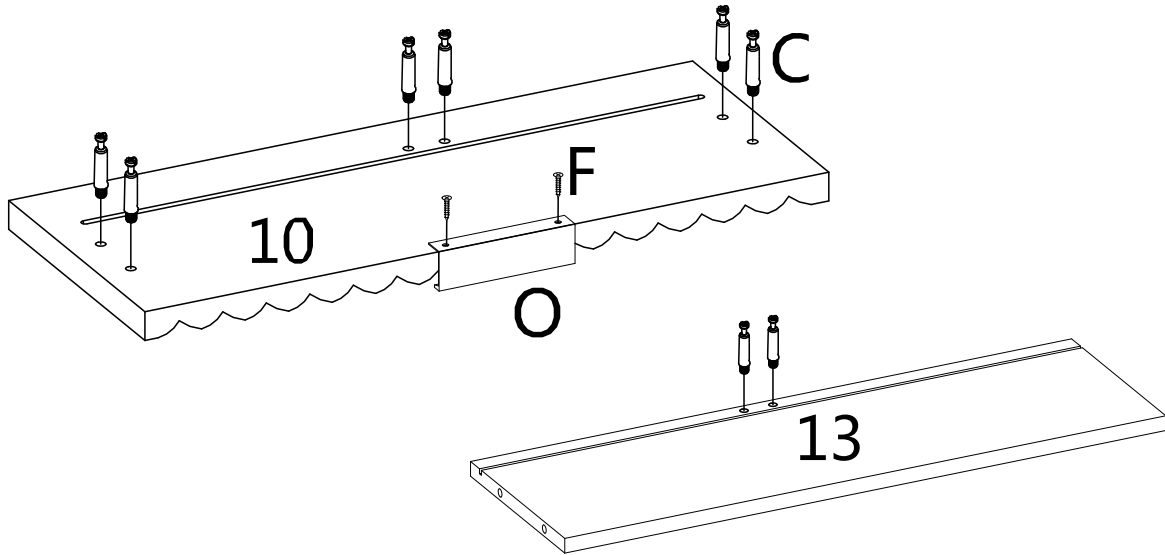
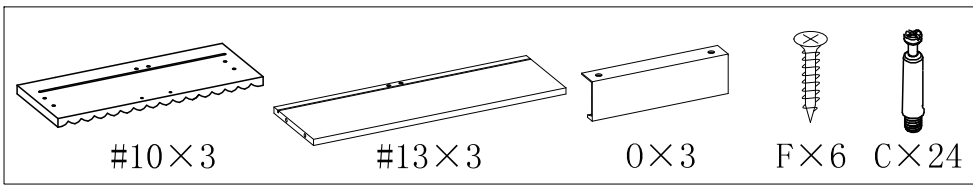

STEP 21

X3

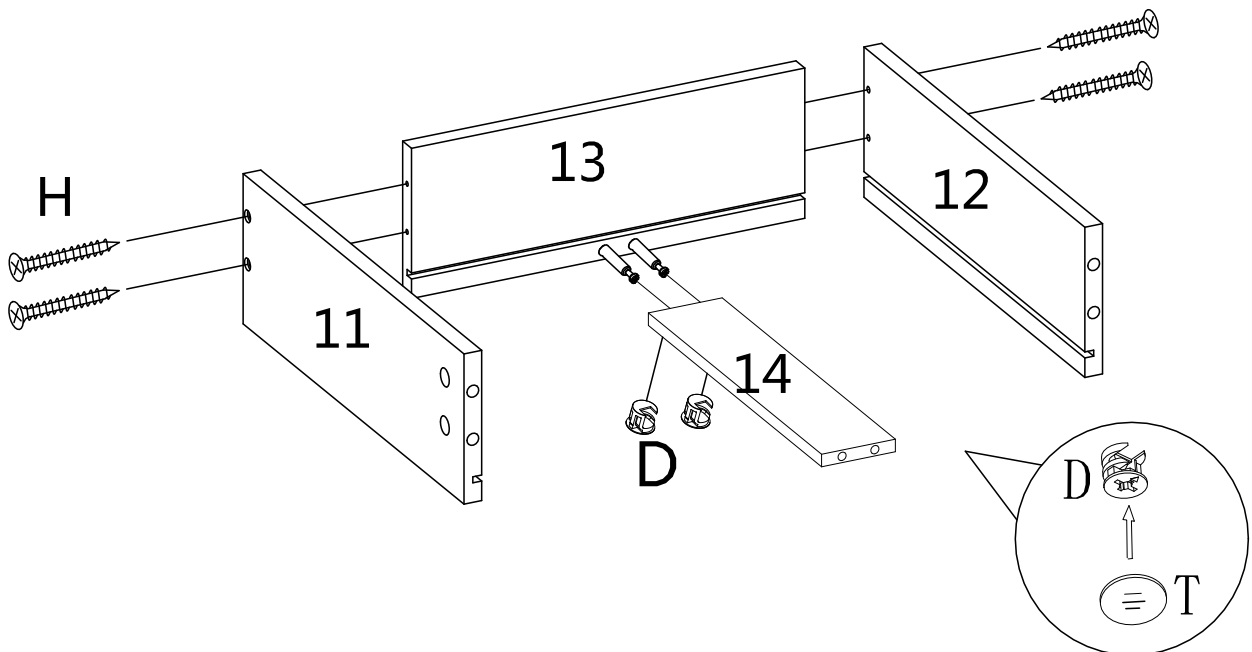
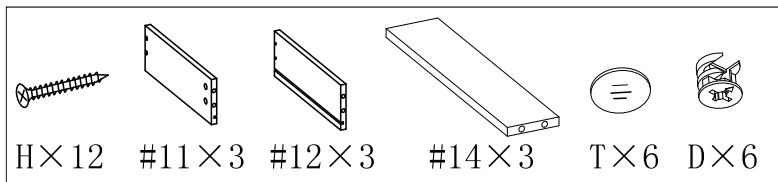

STEP 22

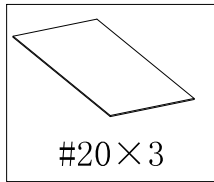

X3

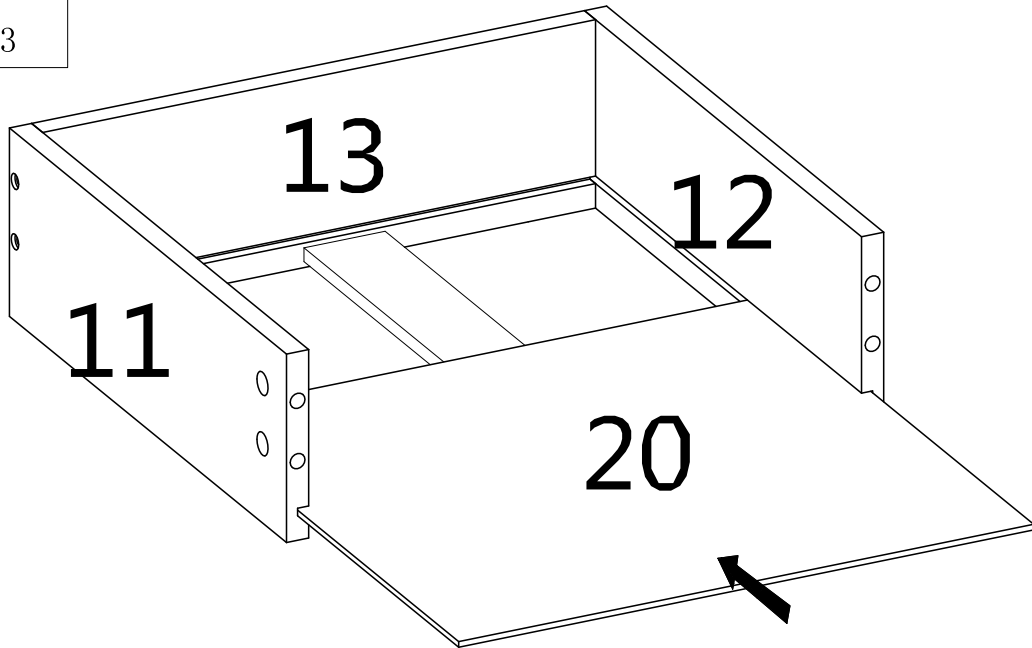

STEP 23

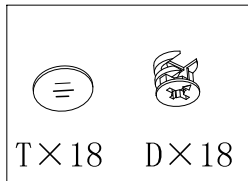

X3

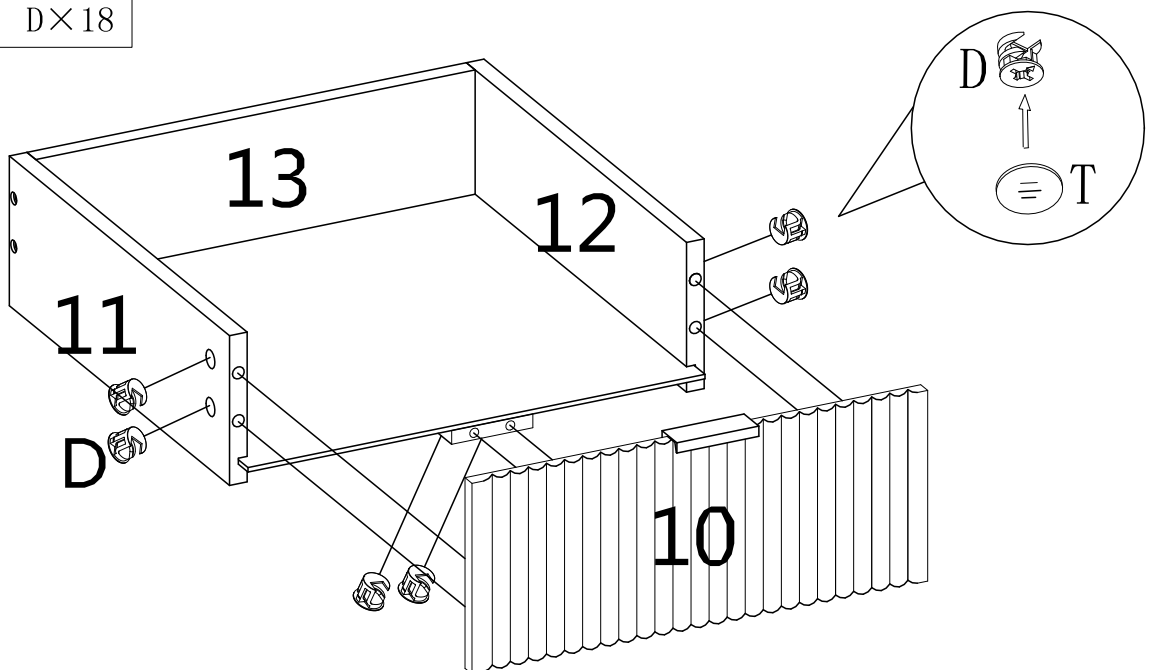

STEP 24

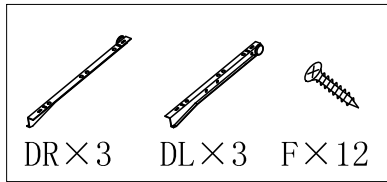

X3

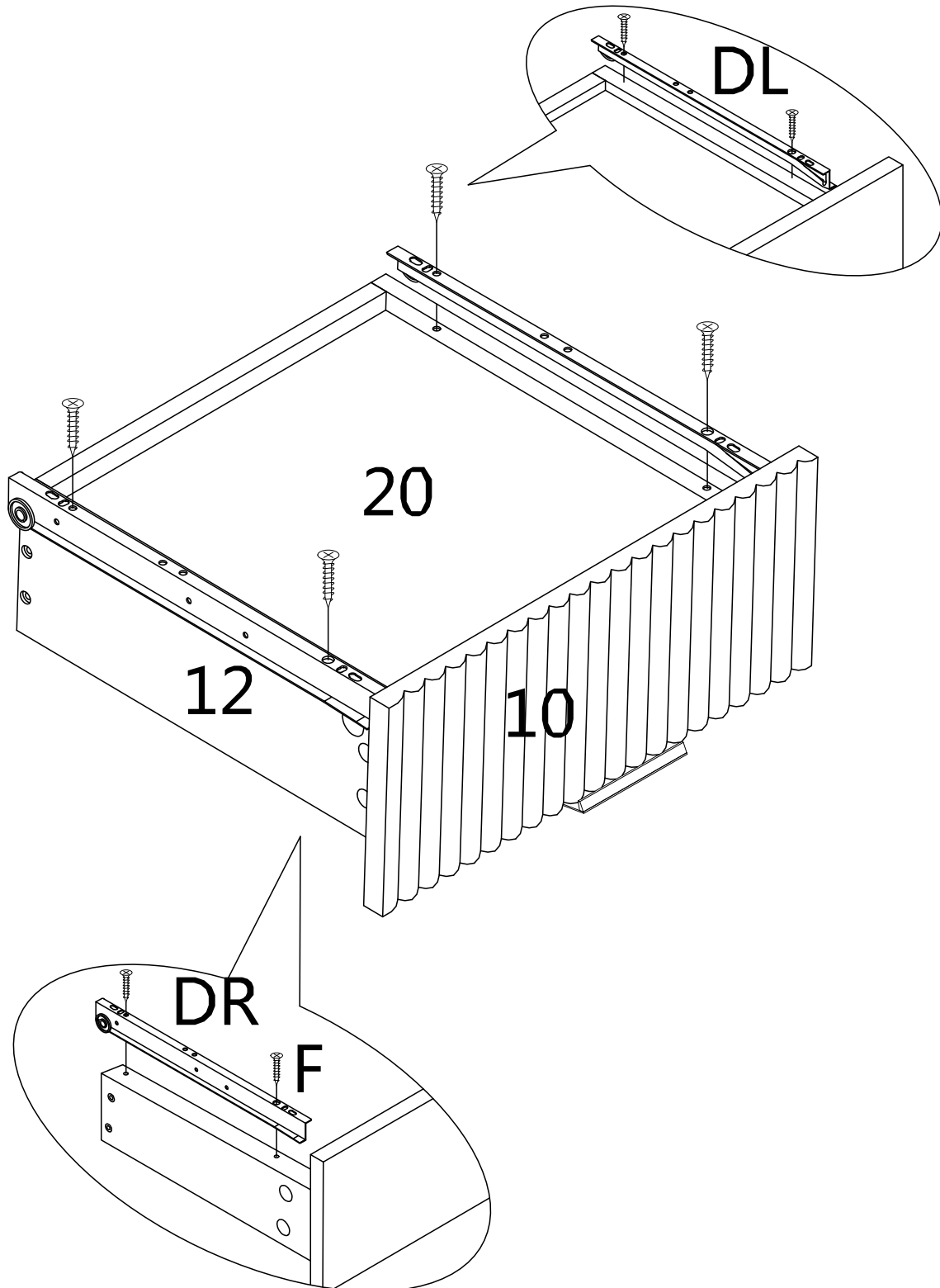

STEP 25

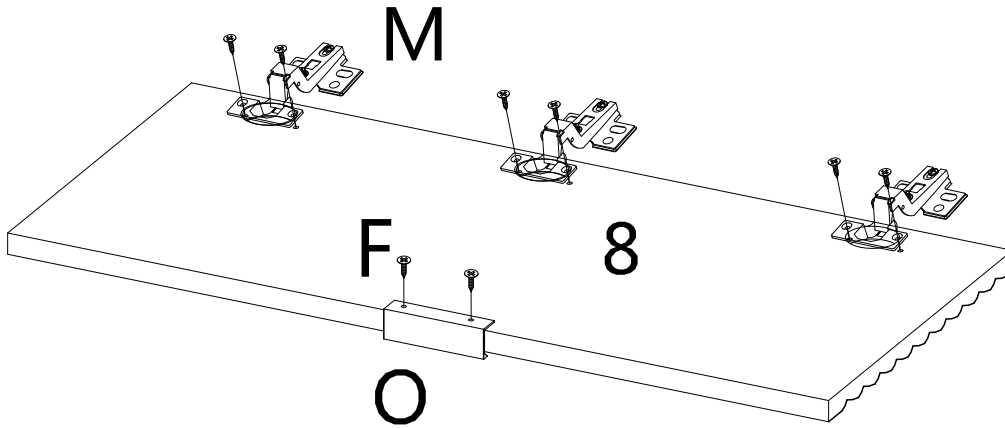
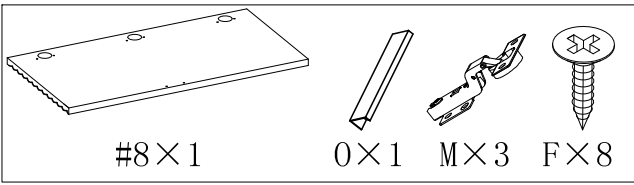

STEP 26

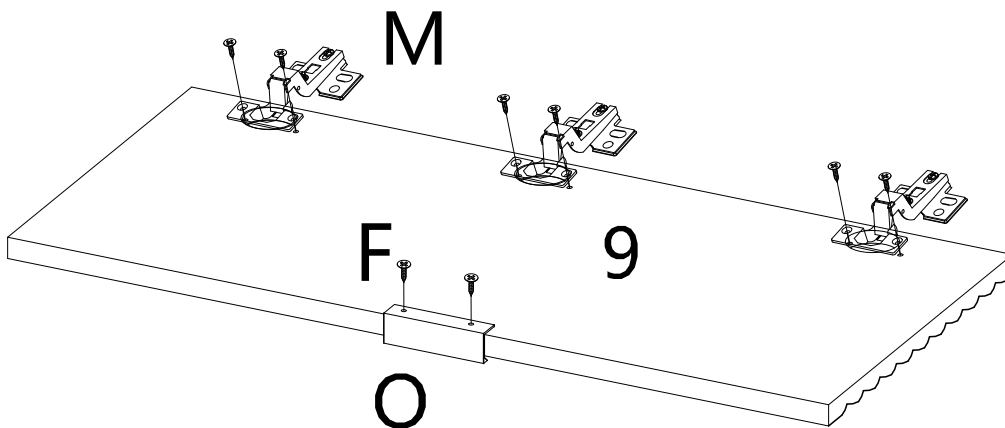
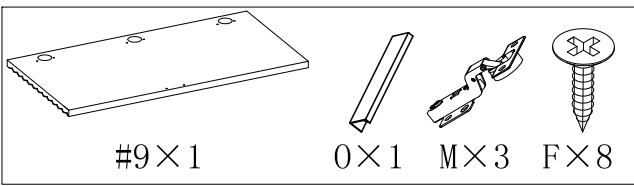

STEP 27

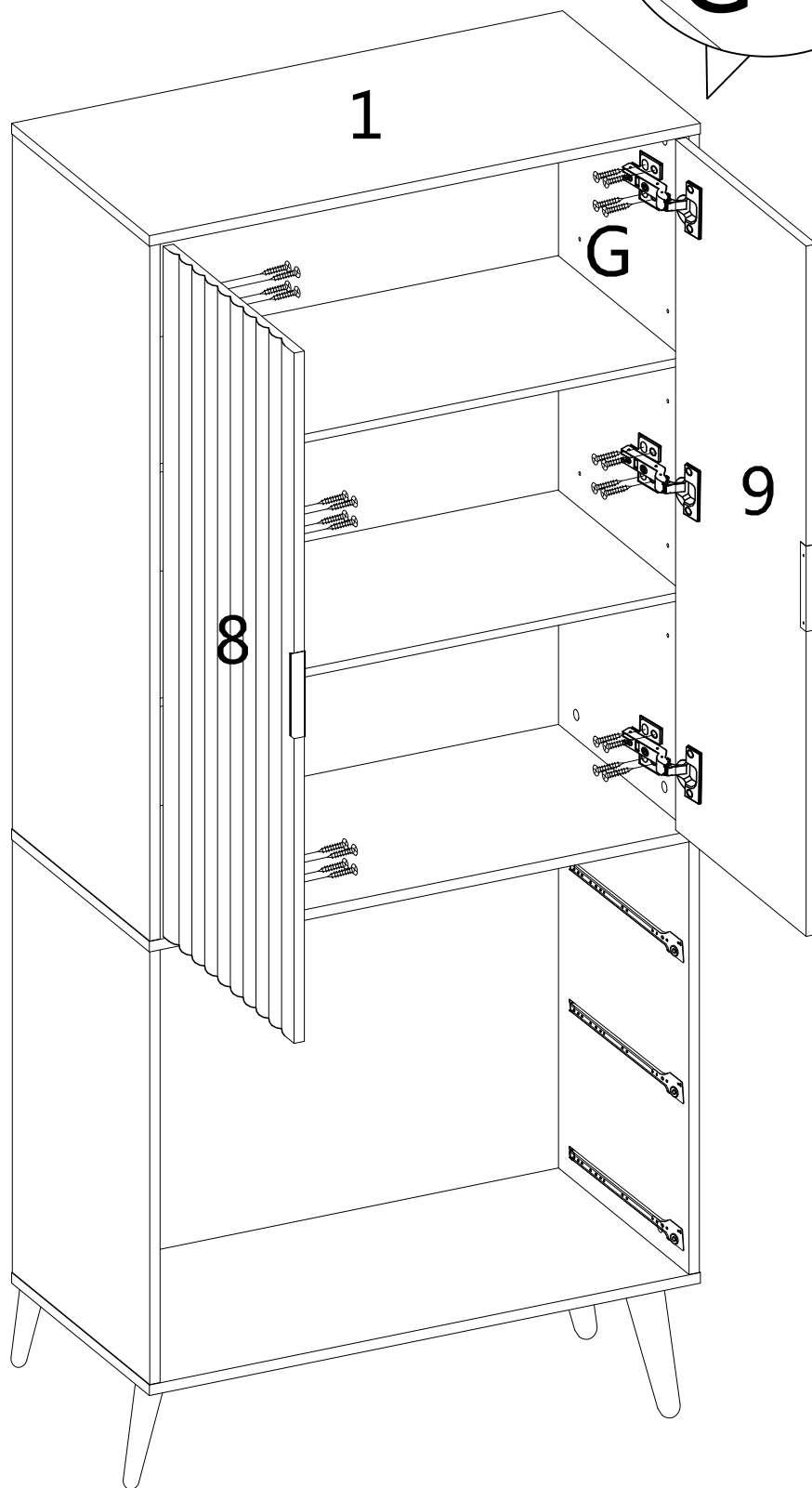
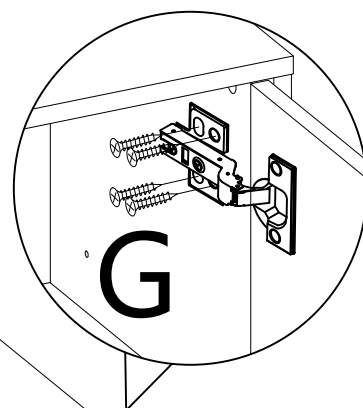
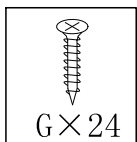

STEP 28

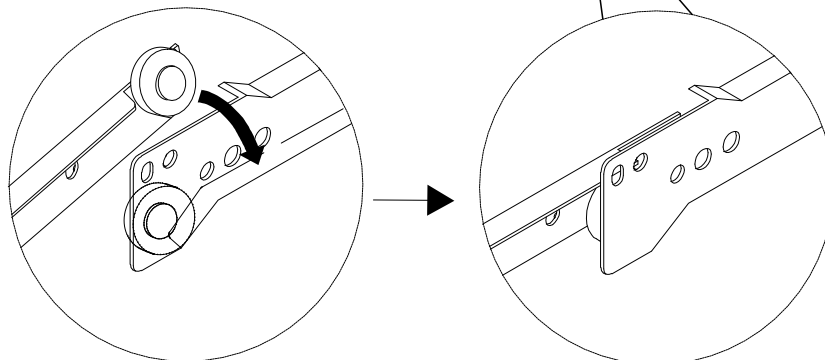
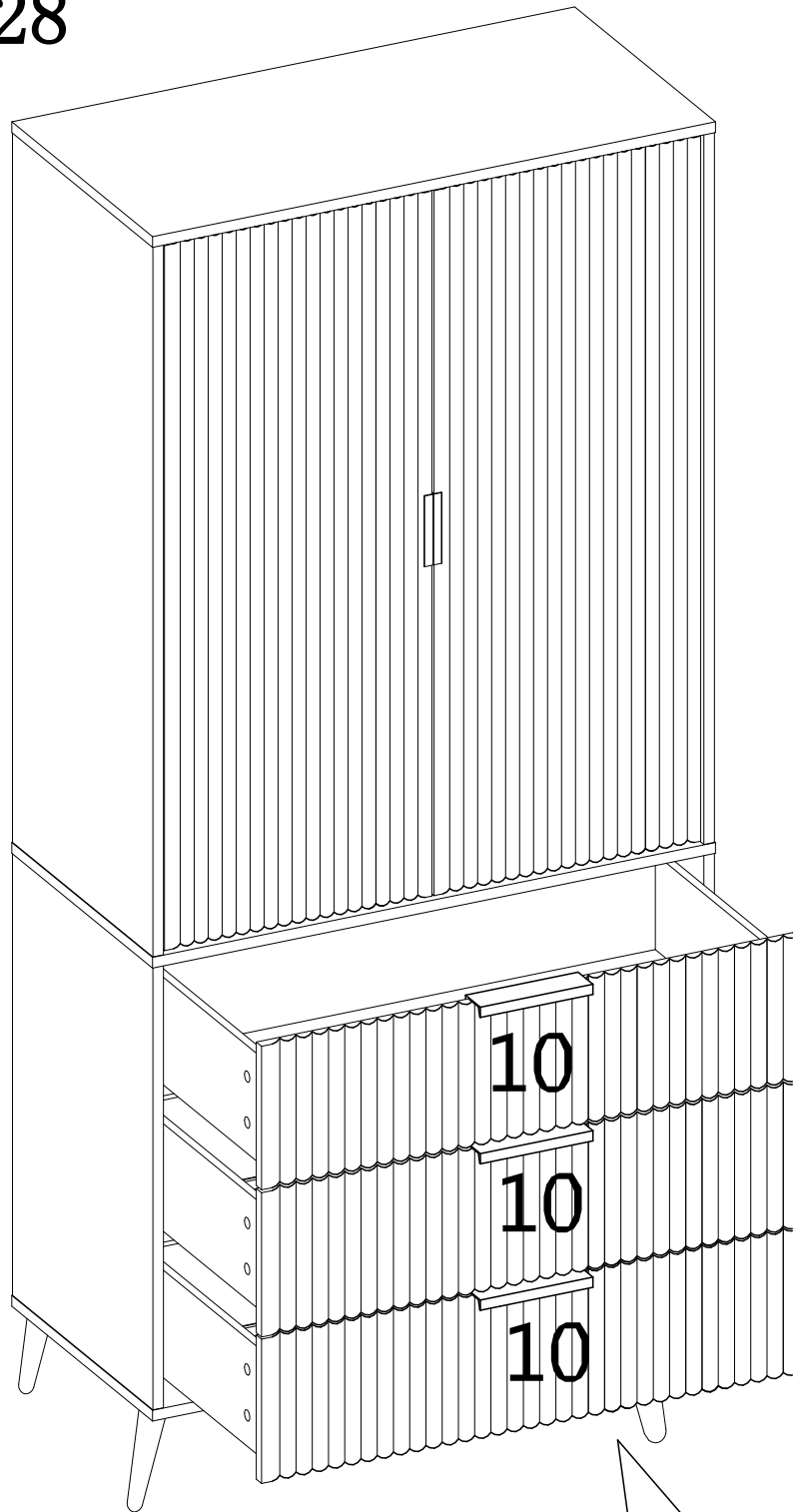

STEP 29

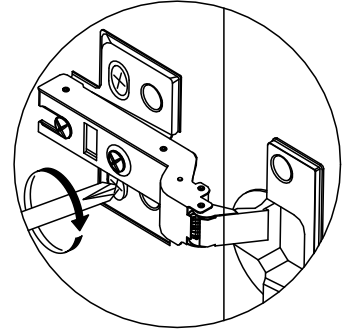
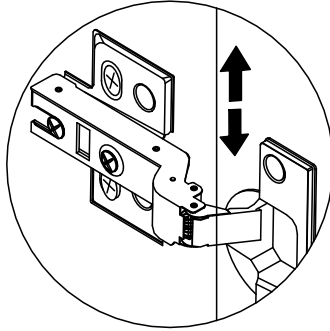
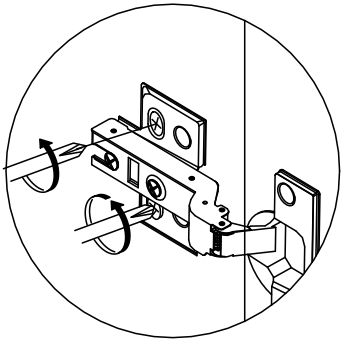

Move panel in and out to match with the screw shown, and retighten the 4 screws.

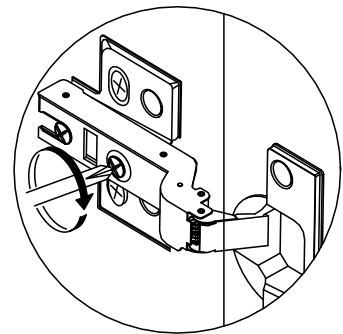
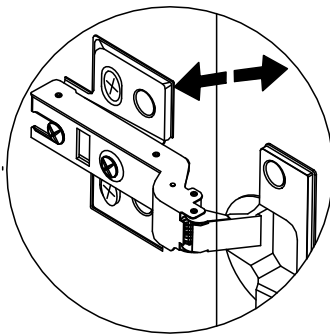
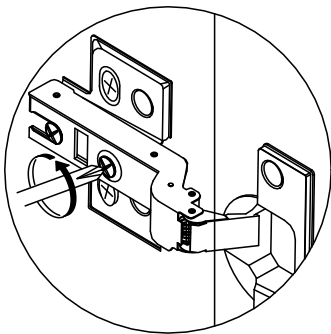

When the panels connected by the hinge cannot close properly, please loose the 4 screws and move the panel top and down to relocate the position of hinge with the screws shown.

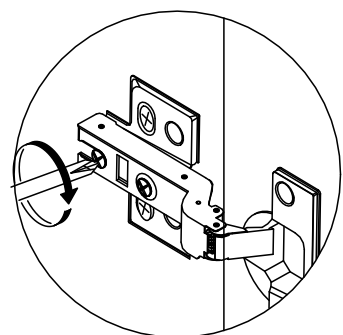
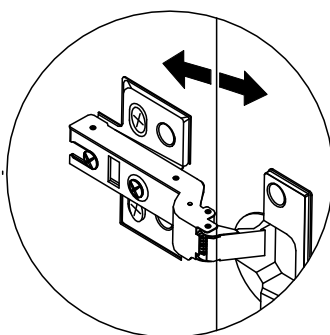
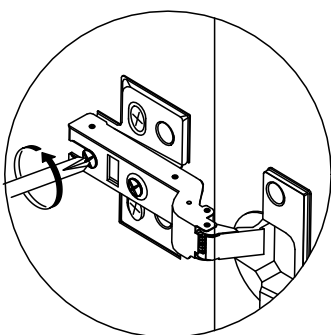

Move panel left and right to match with the screw shown.

STEP 30

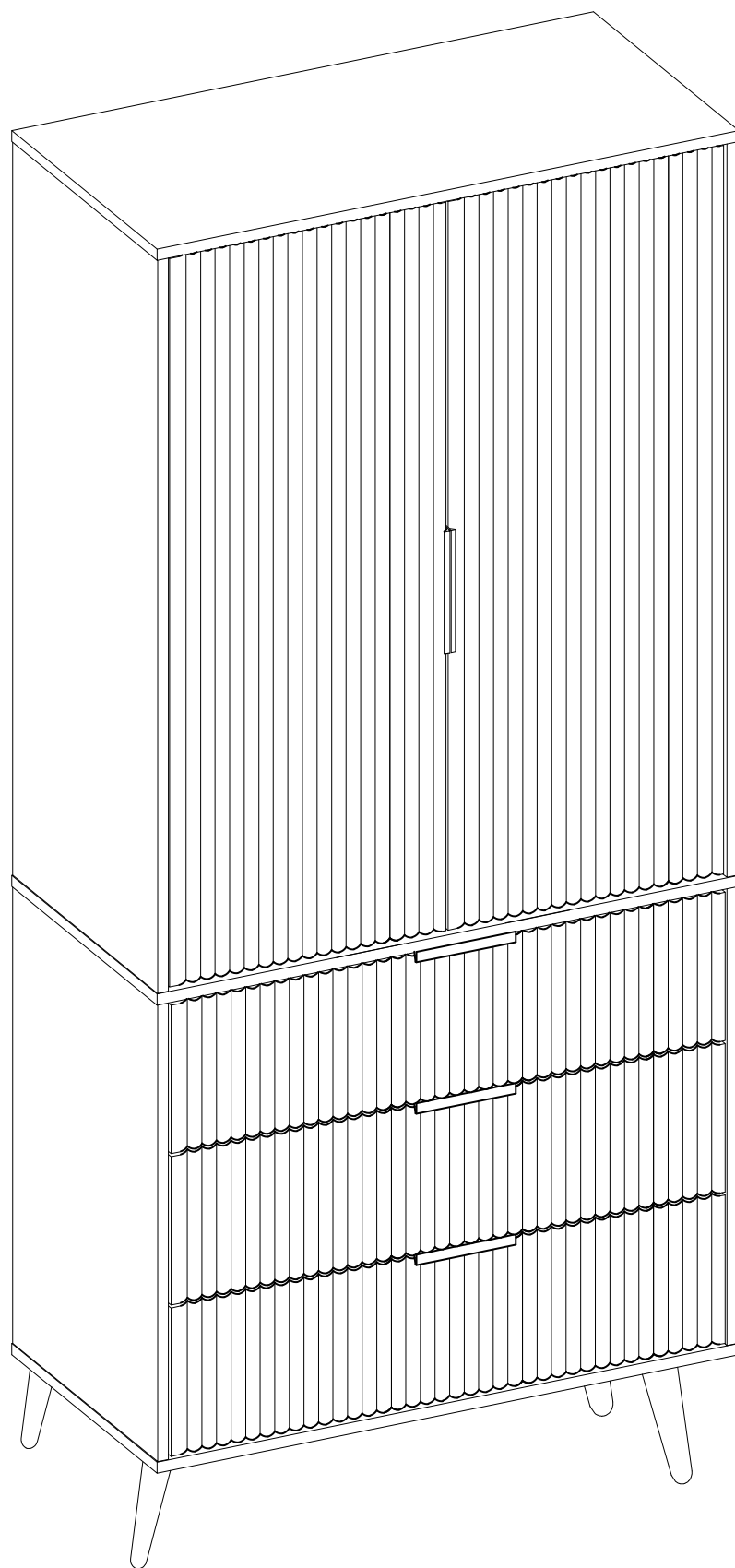

Warning:

Seller is responsible for the product-related issues occurred upon receipt, but will not be responsible for the personal injury, property damage or loss resulting from the incorrect assembly, improper use, inadequate maintenance or neglect of this product.