

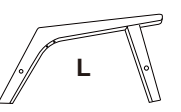

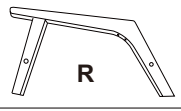

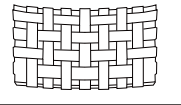

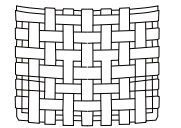
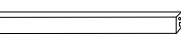

ASSEMBLY INSTRUCTIONS

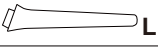
A		1PC
B		1PC
C		1PC
D		1PC
E		2PCS
F		1PC
G		1PC
H	 M8*60	8PCS
I		1PC
J	 M8*40	8PCS
K		4PCS
L		1PC
M		4PCS

Step1

EX2
LX1

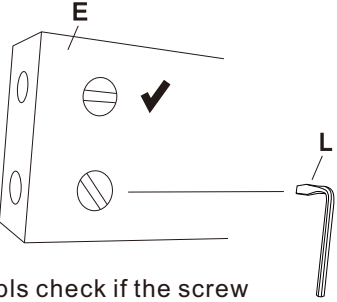

Before assembling, pls check if the screw holes of part [E] are in the right position. If not, pls use part [L] to adjust the screw holes to right position.

Step3

EX2
HX4
IX1

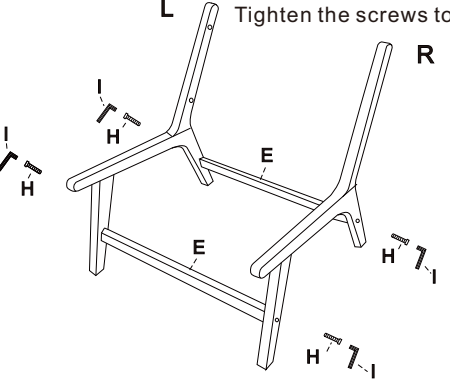

Tighten the screws to 80% tightness.

Step5

I X1

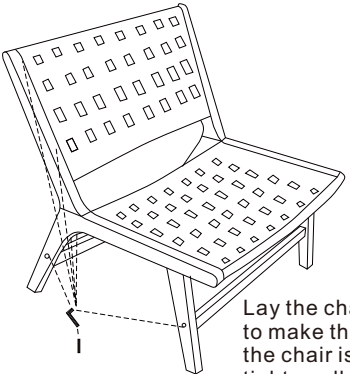

Lay the chair flat and wiggle the chair to make the screws in place. Ensure the chair is level on the floor. Then tighten all the screws to 100%.

Step2

AX1
BX1
FX1
GX1
HX4
IX1

Tighten the screws to 80% tightness.

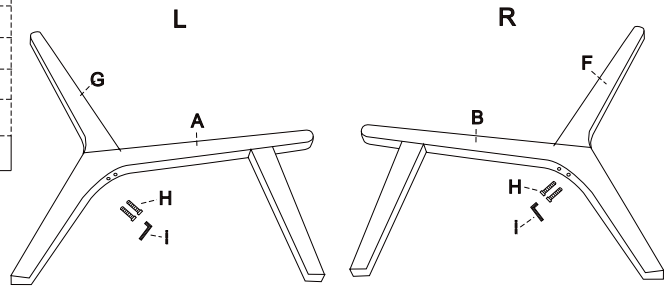

Step4

CX1
DX1
J X8
I X1

Tighten the screws to 80% tightness.

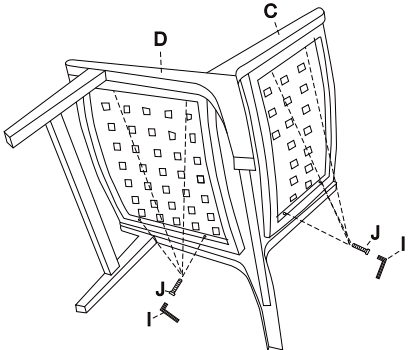

Step6

KX4
MX4

Max Weight Capacity 330LBS.
Cover all leg screws holes with part [K]; stick the anti-slip foot pads part [M].

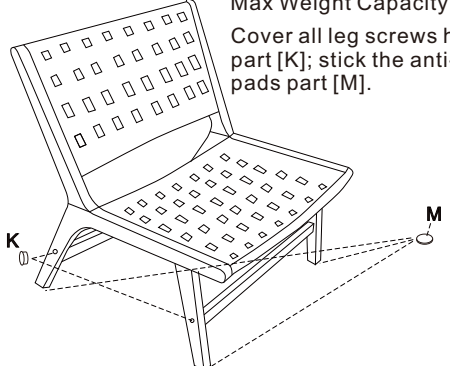

ATTENTION:

1. Please check the manual carefully and make sure you have received all the parts.
2. If there are any missing or damaged, please let us know the letter of the parts you need. Some photos will be highly appreciated. We will reply and offer you a solution soon.