

Assembly Instructions

Caution: You must read this before you proceed.

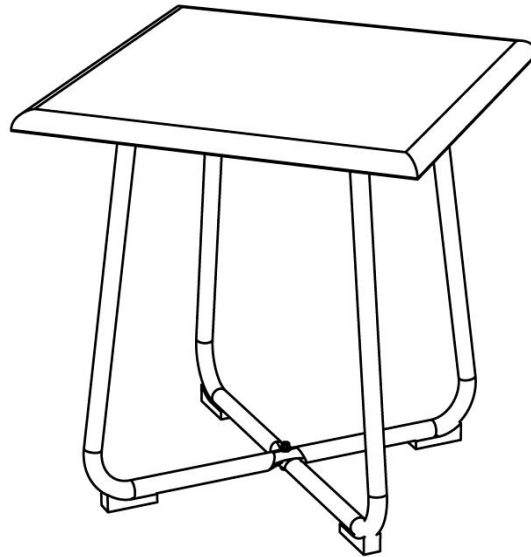



Table

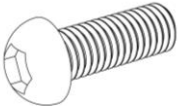

Part List

Label	Picture	Description	QTY
A		Table Top	1
B		Leg (with gap above rail)	1
C		Leg (with gap below rail)	1

Hardware

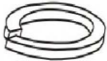
Label	Picture	Description	QTY
①		Bolt (M6X24mm)	1
②		Bolt (M6X15mm)	9
③		Allen Key	1
④		Washer	9
⑤		Nut	1
⑥		Spring Washer	9

Assembly Preparation

Before Beginning Assembly:

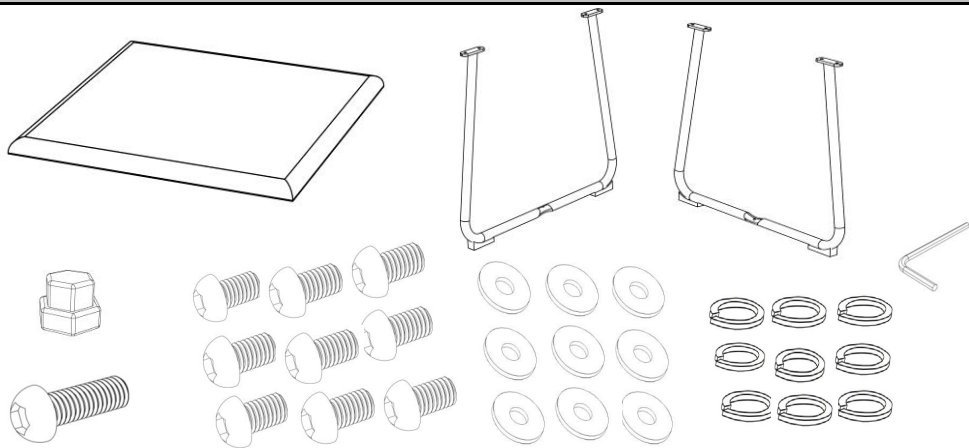

- Read instructions, cover to cover-



- Have 2 adults on hand for assembly-



- Do not assemble on flooring or carpet-



- Assemble on a clean non-marring surface (packing foam)-



- Save all packaging until finished-

Assembly Steps

Overview

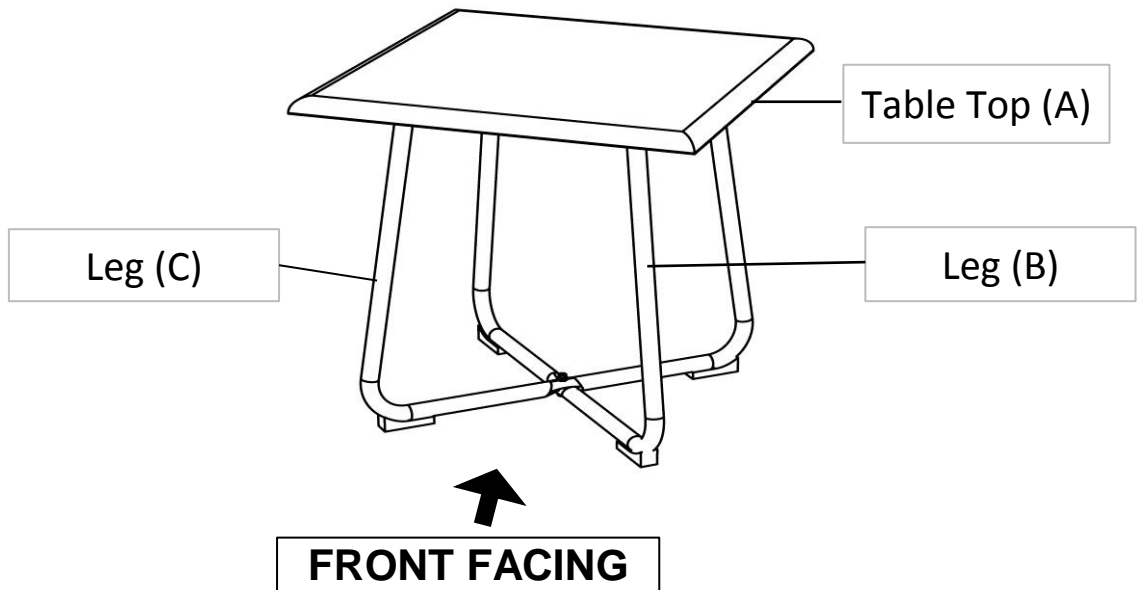

This Table has multiple parts and may require up to 30 minutes to assemble. To give you an overview of the Table parts, the above picture is to help you put the various parts into perspective. Please read through the instructions below to familiarise yourself with the parts and steps before assembly.

Step 1

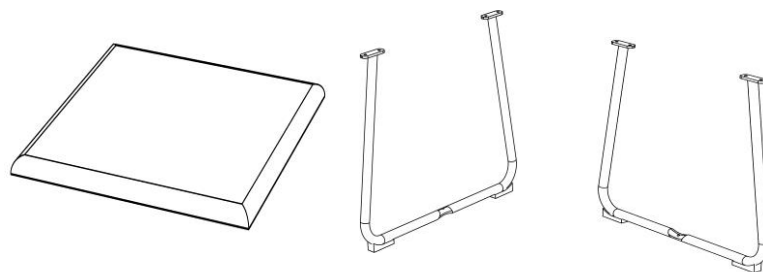

Remove all Parts from package, and place onto a clean, non-marring surface.

Step 2

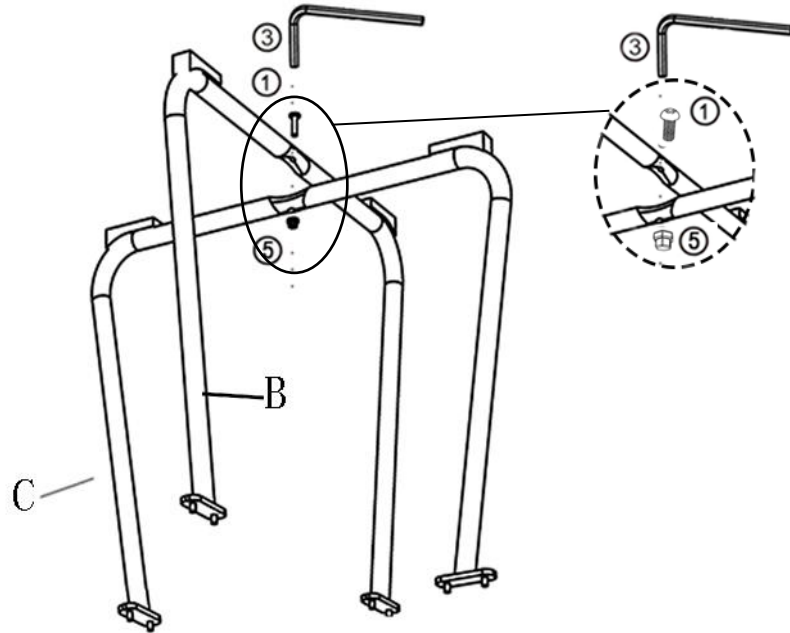

Align the mounting positions of Leg(B) and Leg(C) as shown above, then attach using Bolt(①) and Nut(⑤) with Allen Key(③).

Step 3

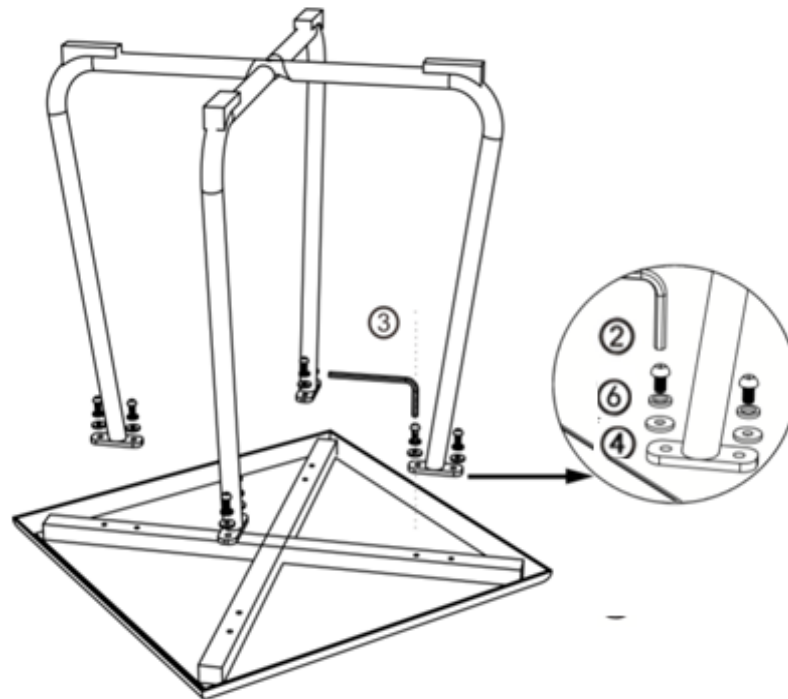

Carefully place the Table Top(A) facedown on a clean, non-marring surface.

Align the mounting positions of Legs with Table Top(A).

Attach Legs to Table Top(A) using Bolts(②), Spring Washers(⑥), and Washers(④) with Allen Key(③).

In a sequential manner, fully tighten all Bolts at all joints.

Step 4

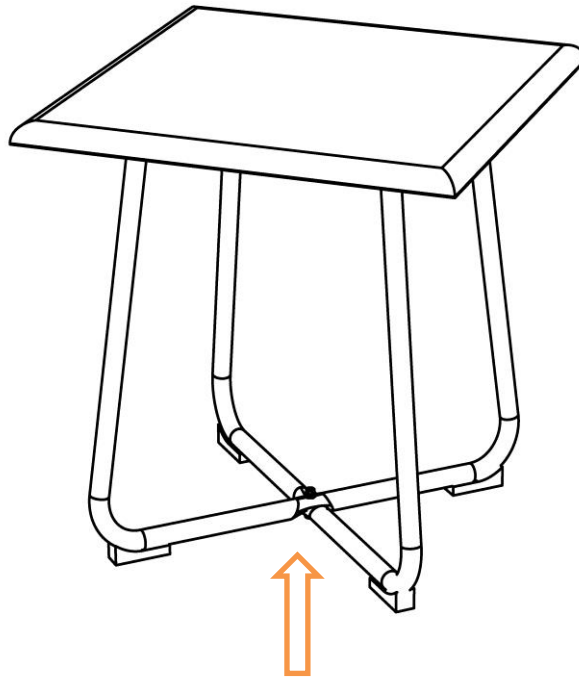



If the table legs cannot horizontal reach the plate, just press the cross as marked by picture

Your Table is now ready for use.

This Table can only be used on a flat, level surface.

Care & Maintenance

-   ● Do not put hot items directly on furniture surface
 -   ● Do not clean furniture with harsh cleansers or polish.
 -   ● To obtain the longest lifespan of your outdoor products, minimizing exposure to direct sunlight is recommended.
 -   ● Children should not climb or jump on the furniture.
 -   ● Do not write on furniture without a padded barrier to protect the surface.
 -   ● To obtain the longest lifespan of your outdoor products, avoid extended and lengthy exposure to rain, snow, and direct sunshine. Whenever possible cover the product and /or place under patio or awnings.
 -   ● Not for commercial use. For residential use only .
 -   ● Stains may be removed with mild soap solution and damp cloth.
-
-   ● Dust and pick-up spills using a clean, non-colored, lint-free cloth .