

FLEXSTEEL®

W1031 / W1032 - 0Q1 / 0Q2 / 0R3

Queen Panel Bed

IMPORTANT

Carefully remove all parts from the carton, and put them individually on a soft cloth to prevent damage to the parts.

We have taken great care in the design of this product and request that you carefully and accurately follow our assembly instructions to ensure proper set-up.

A Phillips Head Screwdriver is required for assembly (Not Provided)

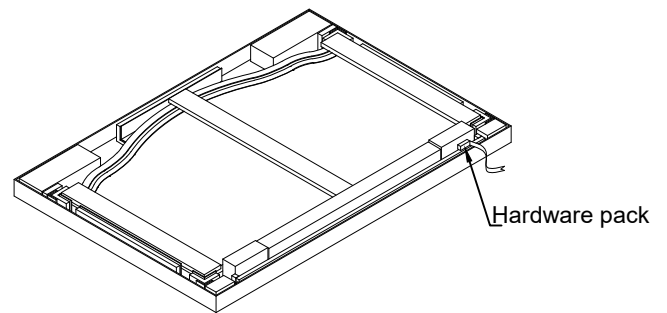
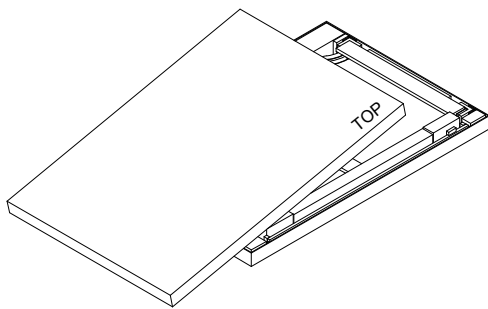
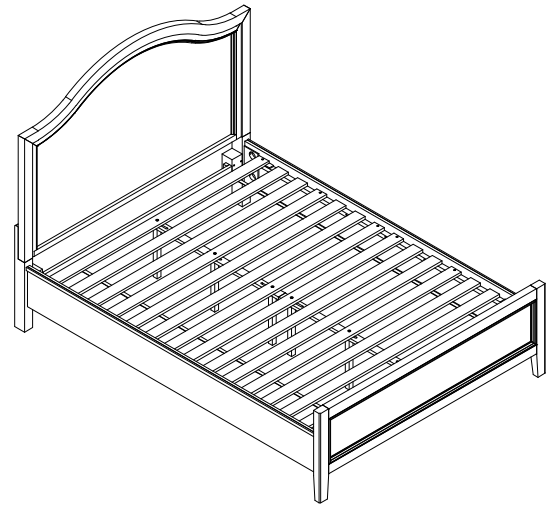

Part List

Assembly Instructions 1/4

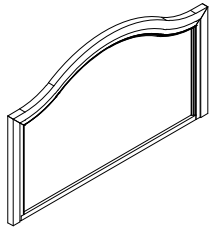

A. Headboard
1 piece

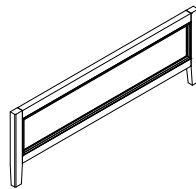

B. Footboard
1 piece

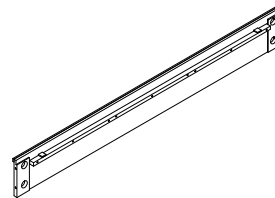

C. Side rail
2 pieces

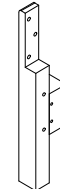

D. Headboard Post Left
1 piece

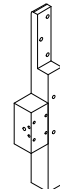

E. Headboard Post Right
1 piece

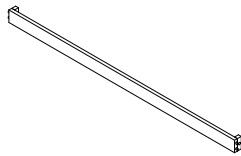

F. Headboard Bottom Rail
1 piece

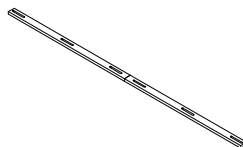

G. Center Rail
1 piece

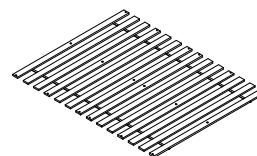

H. Roll Slats
1set



I. Slat Support
6 pieces

Hardware List

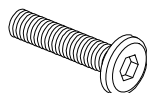

Bolt
Ø5/16" x 18 UNC x 1-1/2"
8 pieces



Spring Washer
Ø5/16" x 1.5mm
8 pieces



Flat Washer
Ø5/16" x Ø19 x 1.5mm
8 pieces

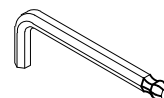

Hex Key
5/32"
1 piece

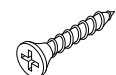

Screw
12 pieces

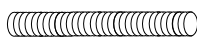

Thread Bolt
Ø5/16" x 18 UNC x 3-1/2"
8 pieces



Curved Washer
1" x 5/8" x 1/16"
8 pieces



Hexagonal Nut
Ø5/16" x 1/2"
8 pieces

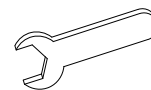

Spanner Wrench
1/2"
1 pieces

FLEXSTEEL®

Assembly Instructions 2/4

IMPORTANT NOTES

- Do not tighten up all the bolts until each part is properly assembled.
- Keep the Hex Key and Spanner Wrench in a safe place as you may need to tighten up the bolts in the future.
- Use a soft cloth between these parts and the floor.
- We recommend this product be assembled by at least two adults.

STEP 1

Fix Headboard Post Left (D) and Headboard Post Right (E) to Headboard Bottom Rail (F). Insert Bolts, Spring Washers, Flat Washers and fully tighten bolts with Hex Key. (See Figure 1)

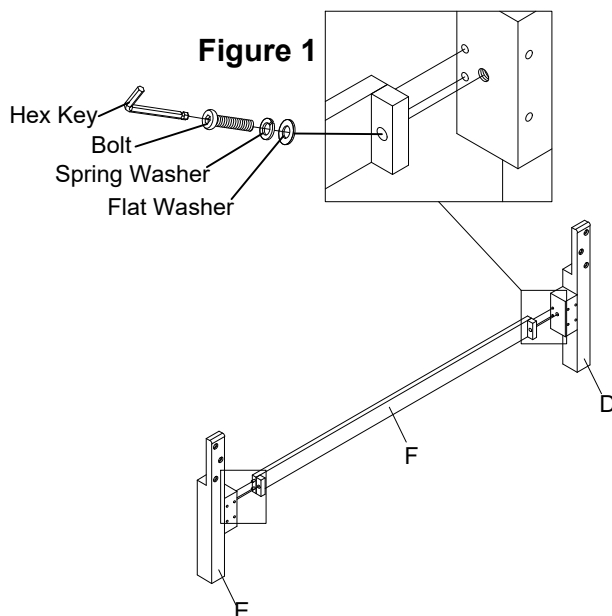

STEP 2

Fix Headboard Post Left (D) and Headboard Post Right (E) to Headboard (A). Insert Bolts, Spring Washers, Flat Washers and fully tighten bolts with Hex Key. (See Figure 2)

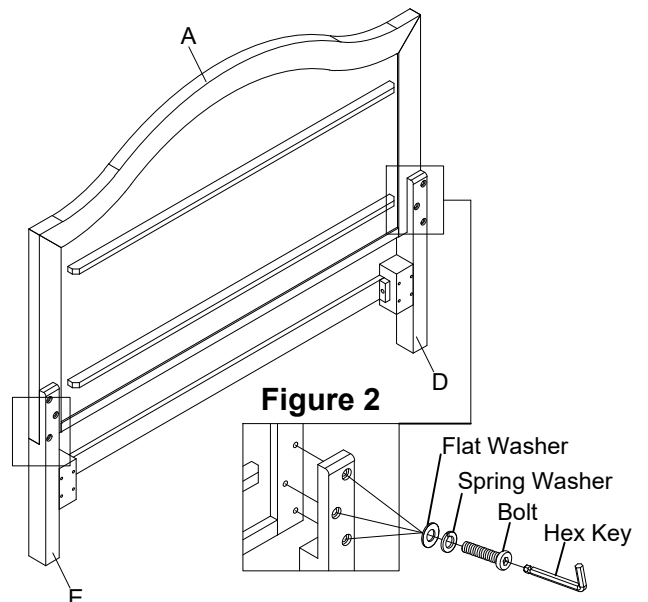

STEP 3

Connect the Side rails (C) to Headboard Post (D) and (E) and Footboard (B). Insert Thread Bolts, Curved Washers, Hexagonal Nuts and fully tighten bolts with Spanner Wrench. (See Figure 3)

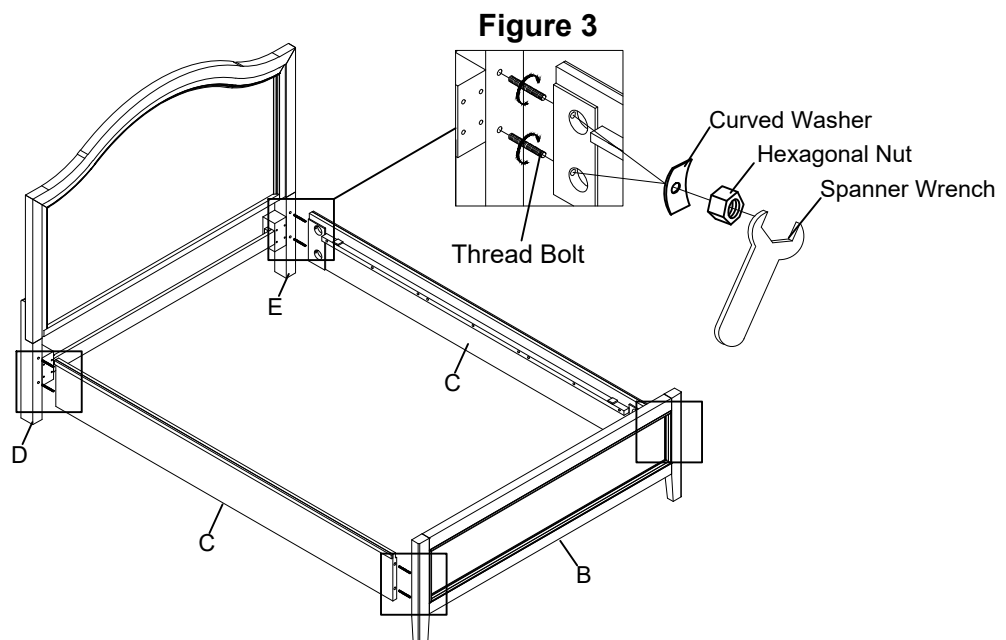

FLEXSTEEL®

Assembly Instructions 3/4

IMPORTANT NOTES

- Do not tighten up all the bolts until each part is properly assembled.
- Keep the Hex Key and Spanner Wrench in a safe place as you may need to tighten up the bolts in the future.
- Use a soft cloth between these parts and the floor.
- We recommend this product be assembled by at least two adults.

STEP 4

Connect the Slat Supports (I) and Center Rail (G) to Roll Slats (H) by passing the bolt on the Slat Supports (I) through the slots in the Center Rails (G), and rotating them by hand clockwise until tight. (See Figure 4)

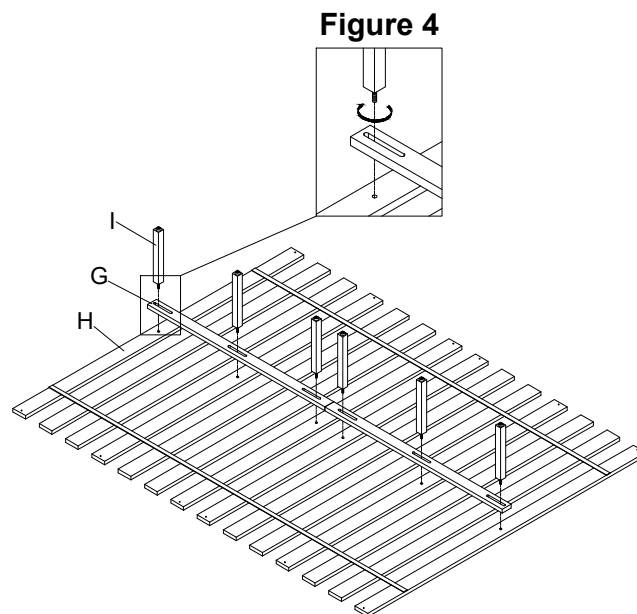

STEP 5

Fix Roll Slats (H) to Side rails (C). Insert Screws. (See Figure 5)

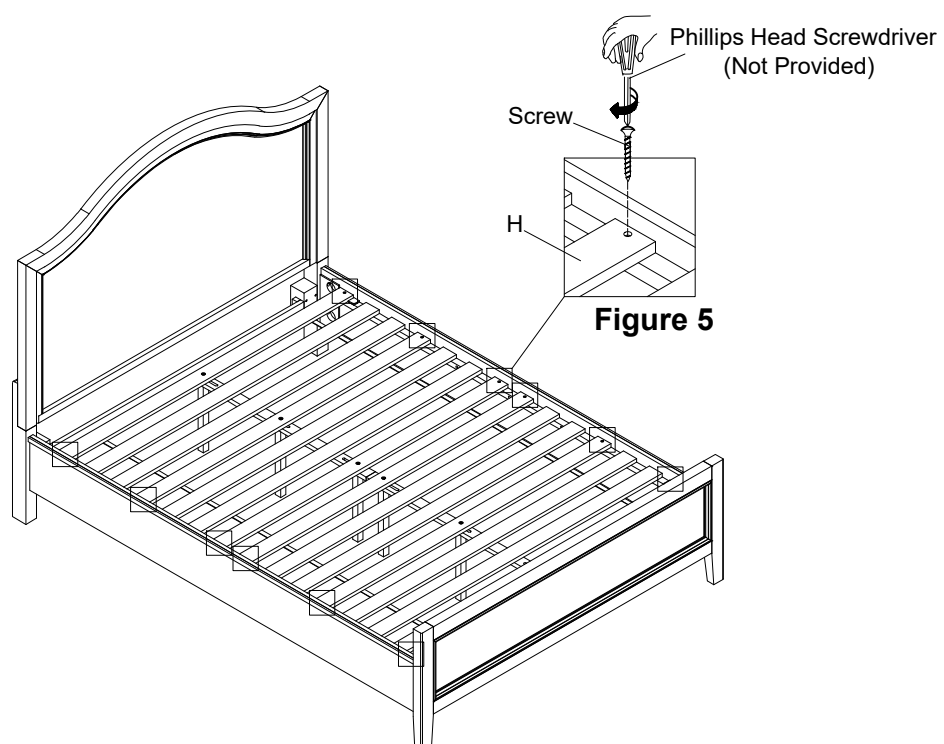

FLEXSTEEL®

Assembly Instructions 4/4

IMPORTANT NOTES

- Do not tighten up all the bolts until each part is properly assembled.
- Keep the Hex Key and Spanner Wrench in a safe place as you may need to tighten up the bolts in the future.
- Use a soft cloth between these parts and the floor.
- We recommend this product be assembled by at least two adults.

STEP 6

Adjust the levelers on the Slat Supports (I) to ensure they are all touching the floor. (See Figure 6)

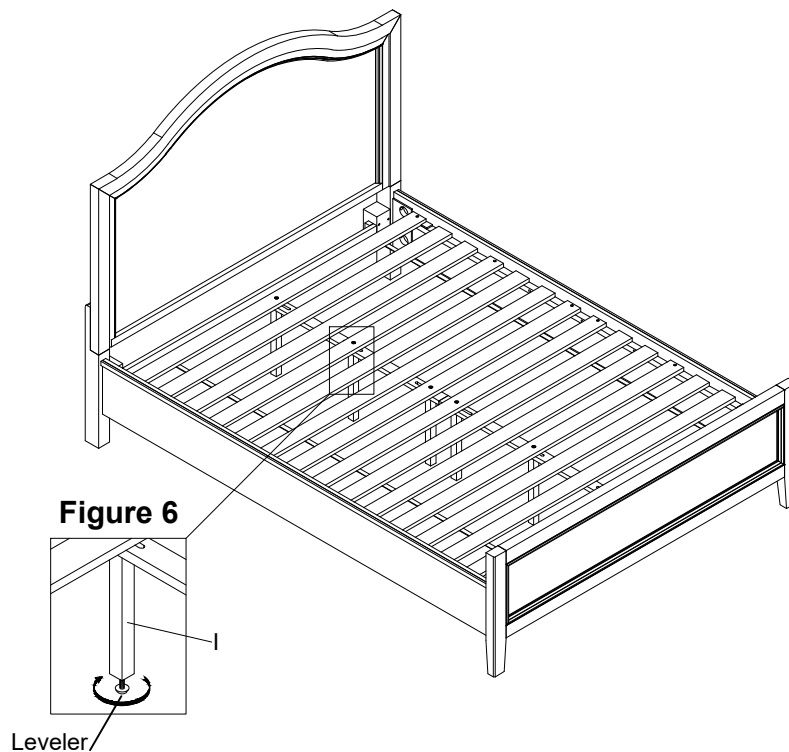

CARE INSTRUCTIONS

- To avoid scratches, do not place sharp or jagged objects directly on the bed.
- Do not place hot items directly on the bed.
- Avoid the use of harsh chemicals or abrasive cleaning materials.
- Wipe the bed clean with a soft, dry cloth after each use.
- Wipe up spills quickly with a soft, dry cloth.

Flexsteel Industries, Inc.

For Parts or Customer Service call

toll-free:

1-888-415-3979

Monday-Friday

8:00 a.m. -5:00 p.m.

(Central Time)

Email:

customersolutions@flexsteel.com

www.flexsteel.com