

THIS INSTRUCTION BOOKLET CONTAINS IMPORTANT SAFETY INFORMATION. PLEASE READ AND KEEP FOR FUTURE REFERENCE.

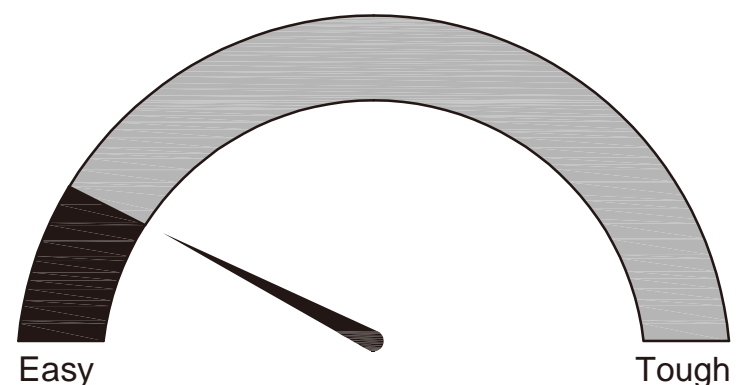

WARNING

- Unit can tip over causing severe injury or death.
- Anchor unit to stud in wall (if instructed to).
- Do Not allow children to climb on unit.
- Put heavy items on lower shelves or drawers.



Assembly Difficulty Meter

Helpful Hints

PEOPLE NEEDED FOR ASSEMBLY: 1 - 2
ESTIMATED ASSEMBLY TIME: 1 HOUR

- Open your item in the area you plan to keep it to avoid excessive heavy lifting.
- Identify, sort and count the parts before attempting assembly.
- Compression dowels are lightly tapped in with a hammer.
- Slides are labeled with a R (right) and L (left) for proper placement.
- Make sure to always face the point on the top of the Cam Lock towards the outer edge.
- Use all the nails provided for the back panel and spread them out equally.
- Back panel must be used to make sure your unit is sturdy.
- Do NOT use harsh chemicals or abrasive cleaners on this item.
- Never push, pull, or drag your furniture.



Before You Start

- Read through each step carefully and follow the proper order
- Separate and count all your parts and hardware
- Give yourself enough room for the assembly process
- Have the following tools: Hammer
- Caution: If using a power drill or power screwdriver for screwing, please be aware to slow down and stop when screw is tight. Failure to do so may result in stripping the screw.

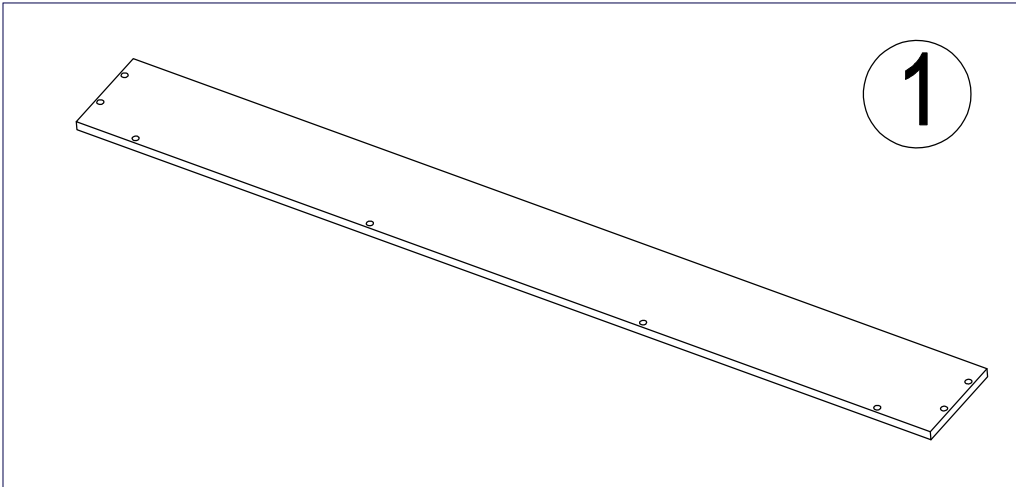
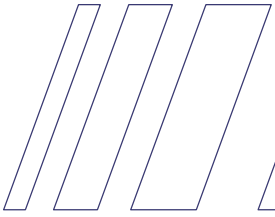

1

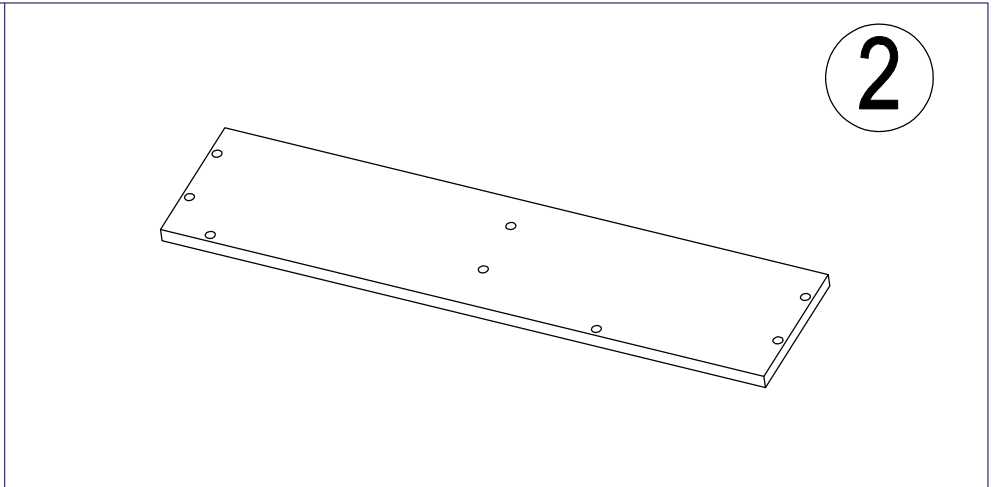

2

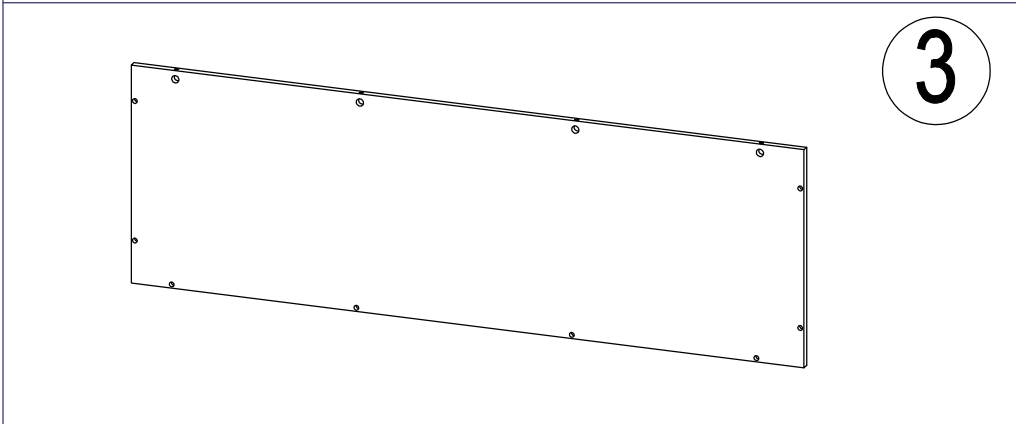

3

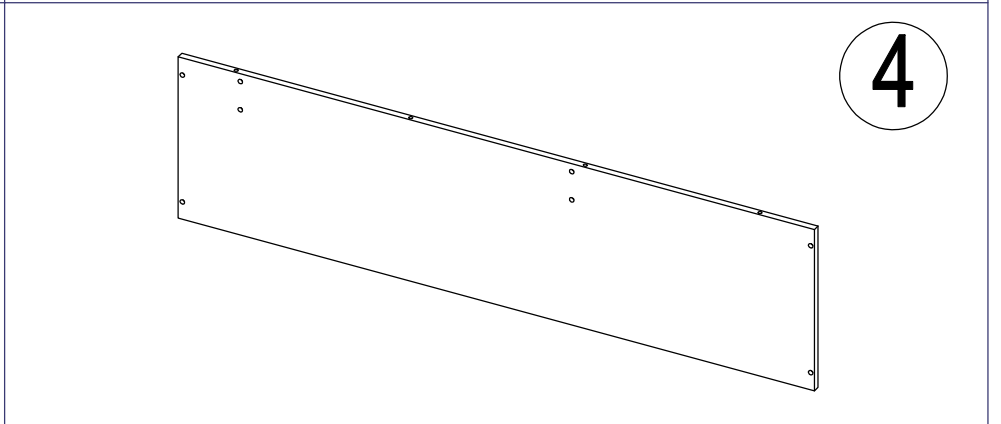

4

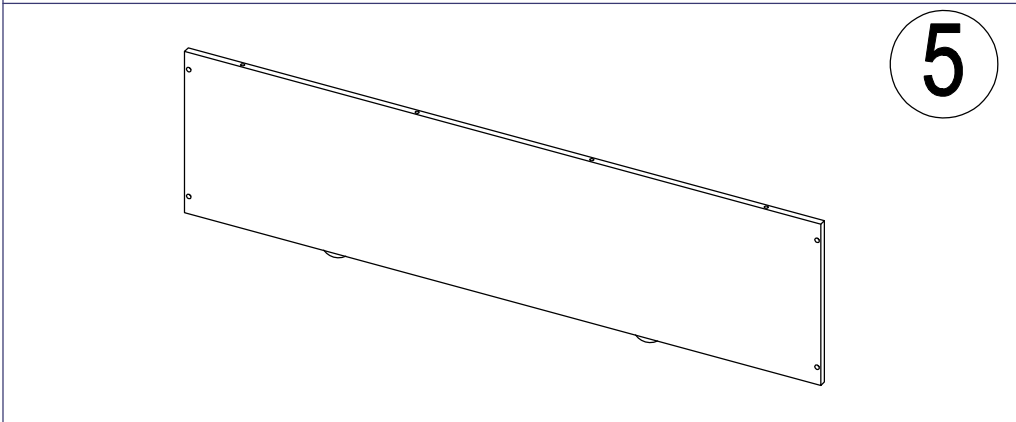

5

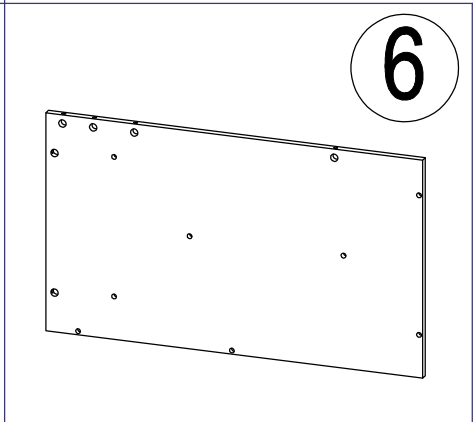

6

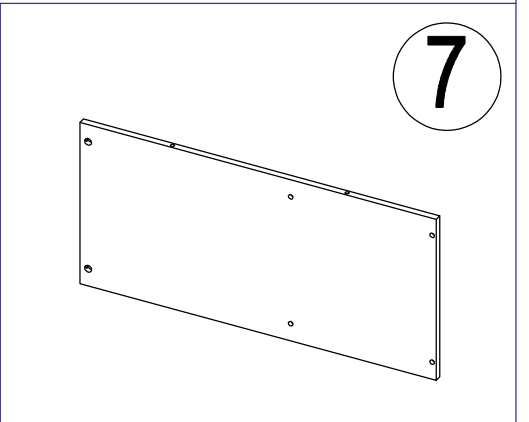

7

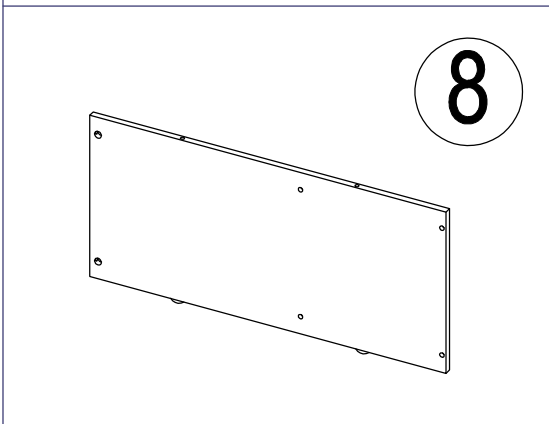

8

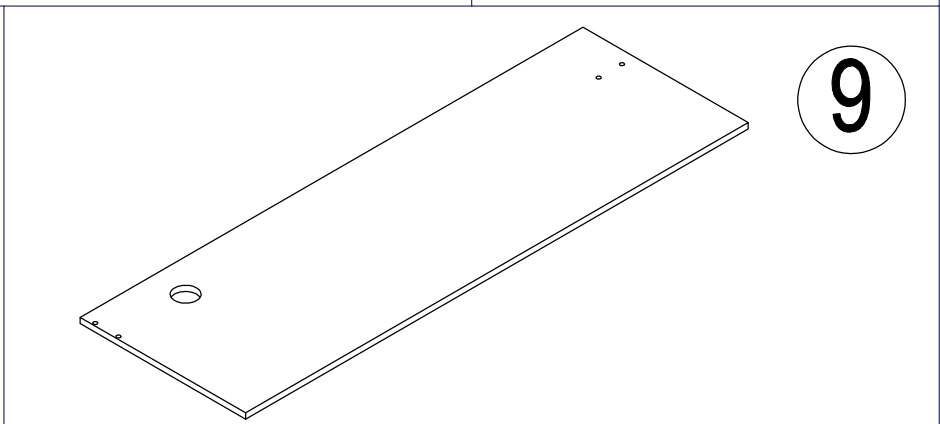

9

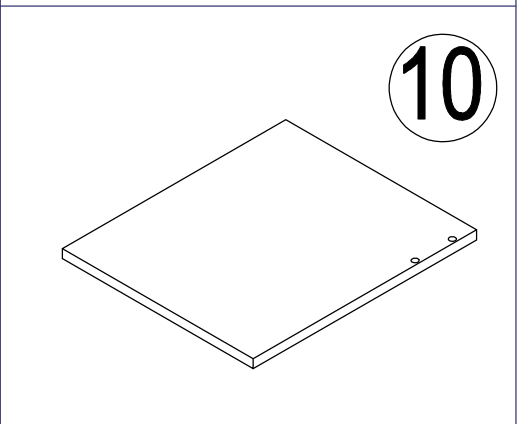

10

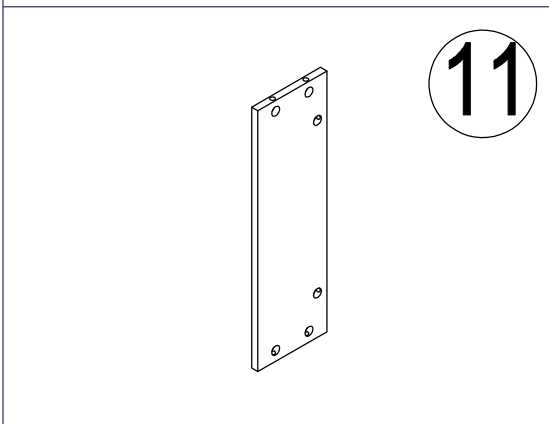

11

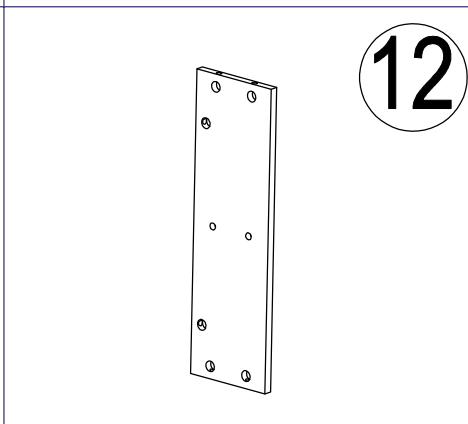

12

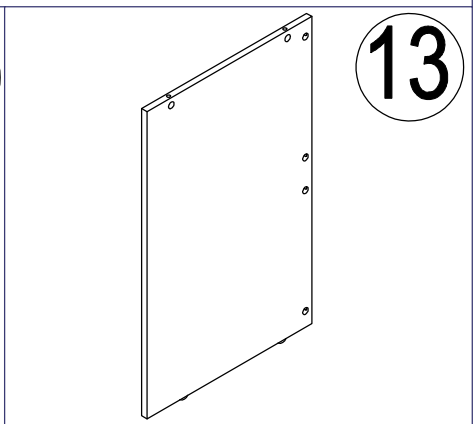

13

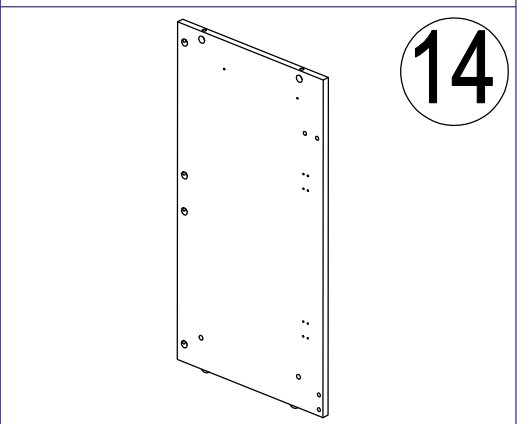

14

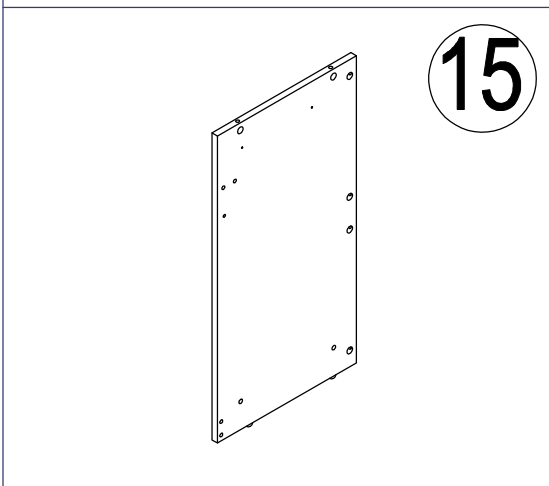

15

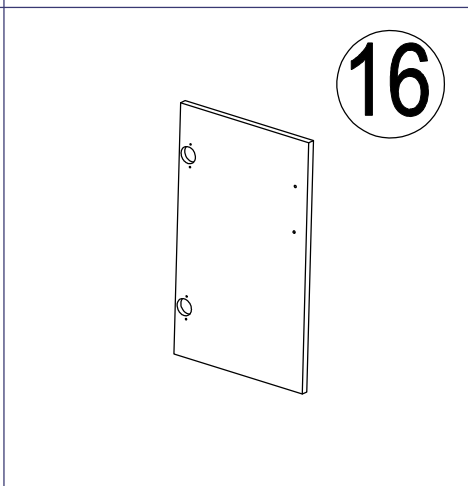

16

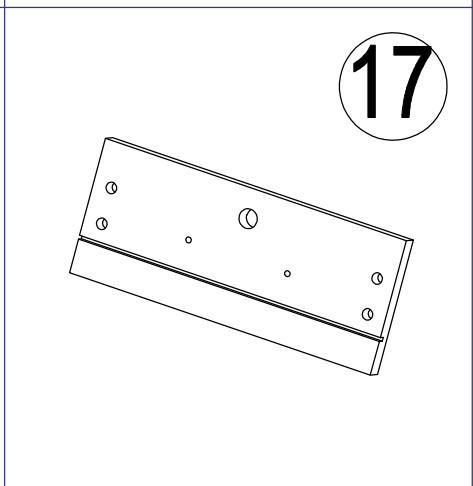

17

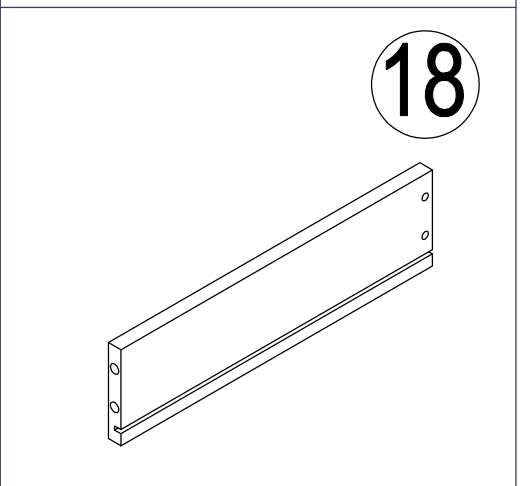

18

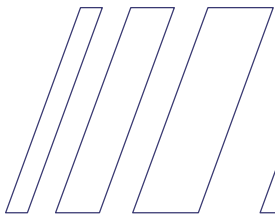

19

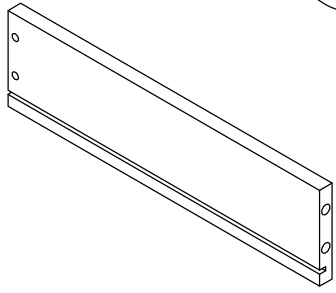

20

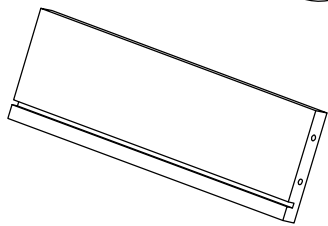

21

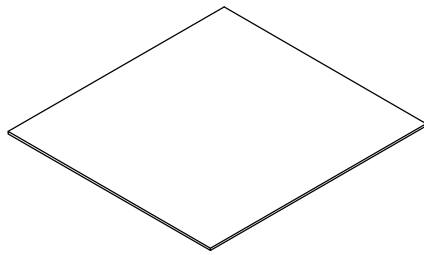

22

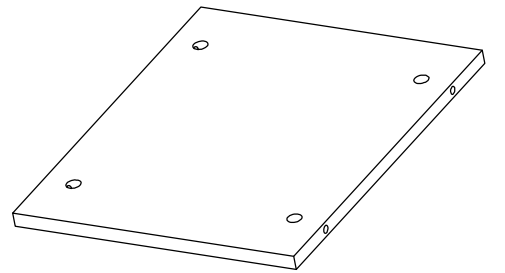

23

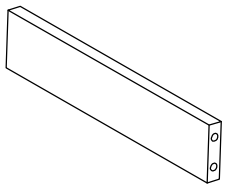

2PCS

24

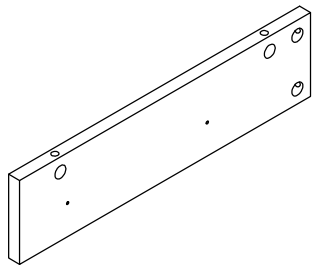

25

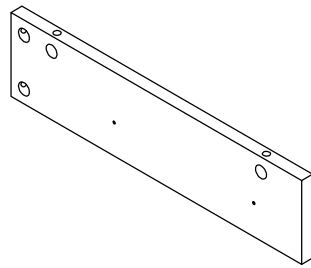

26

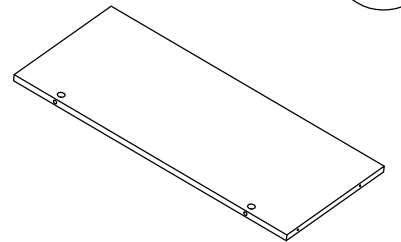

27

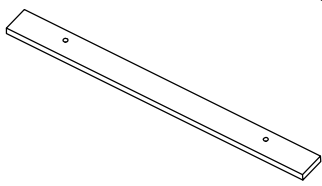

28

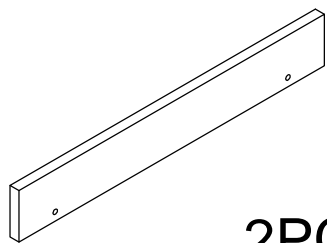

2PCS

29

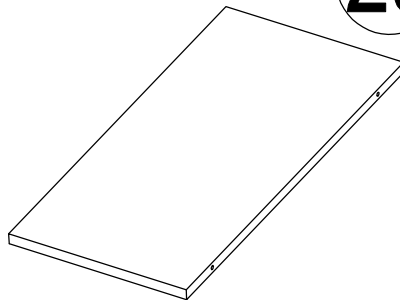

30

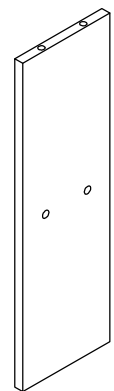

31

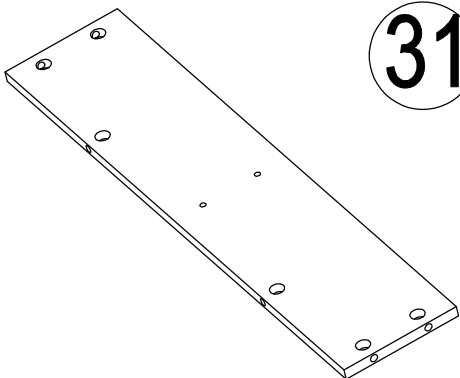

32

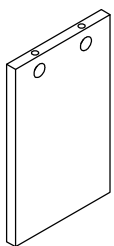

33

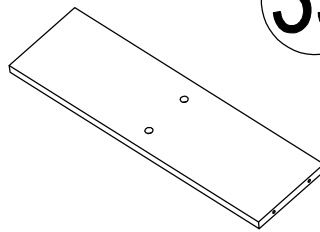

2PCS

34

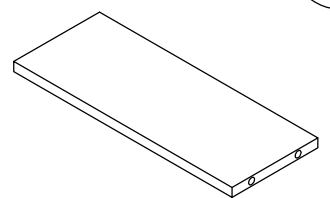

35

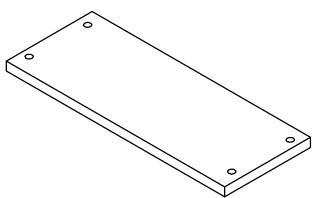

2PCS

36

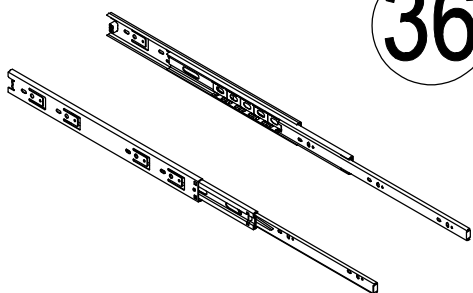



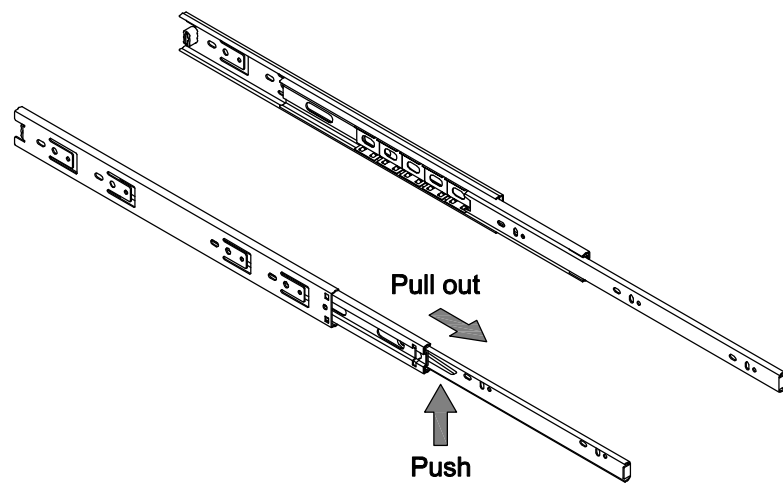



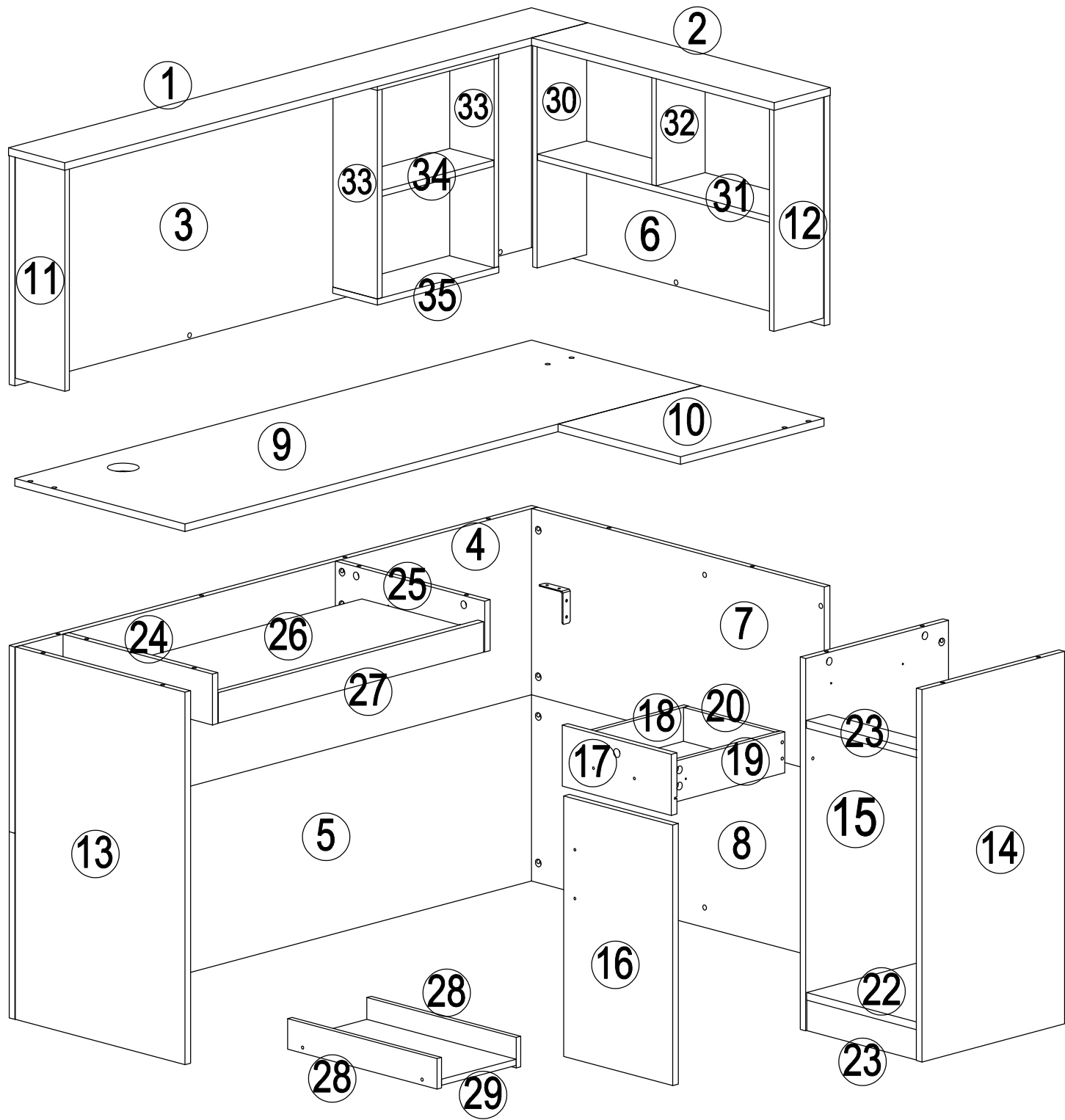

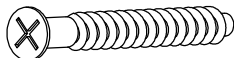

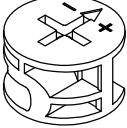
12" 3509W 2 SET

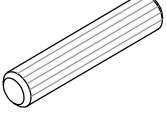

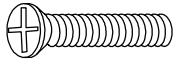
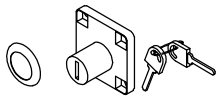
Disconnect the keyboard rail with the BLACK PLASTIC PART. It needs to be pulled down to disconnect the runners.

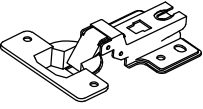
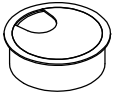

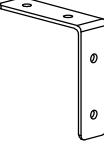
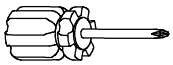
A M3.5x12  X 32+2	B M5x40  X 18+1	C M5x25  X 86+2	D Ø15x10  X 86+2	E M5  X 1	F Ø8x40  X 20+1
G M4x96  X 2	H M4x18  X 4	I  X 1	J M3x18  X 4	K DW  X 2	L Ø60  X 1
			M  X 20	N  X 1	 X 1

M5x25mm

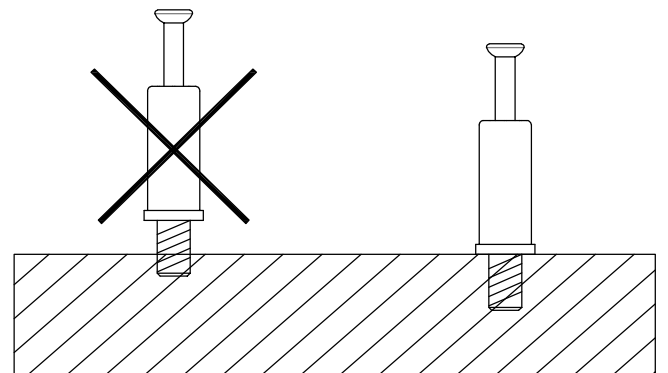
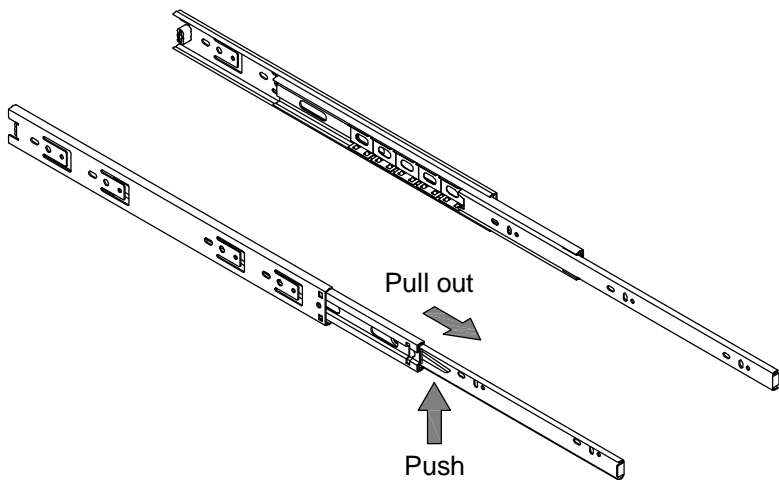
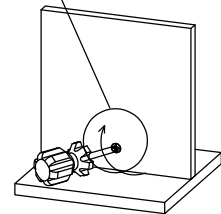
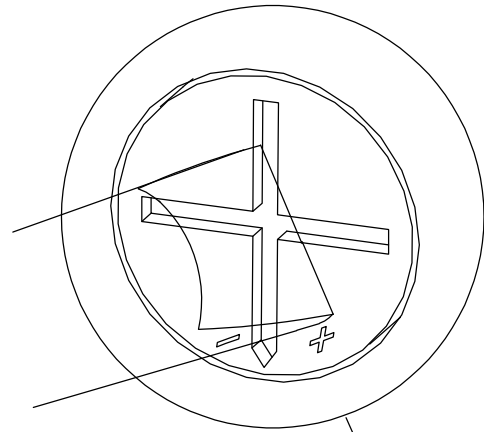
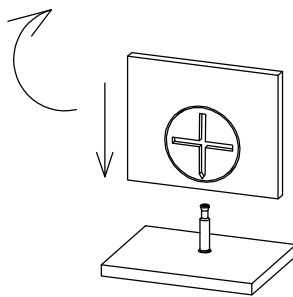
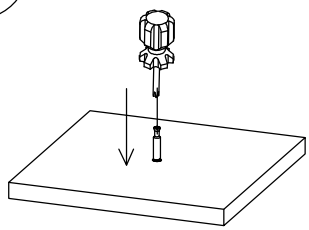
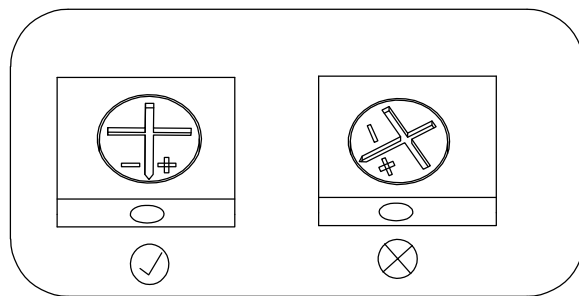
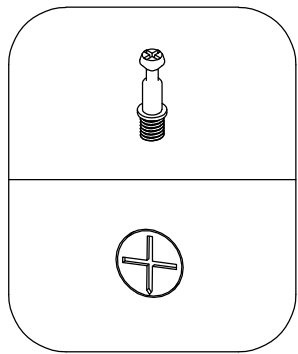

Disconnect the keyboard rail with the BLACK PLASTIC PART. It needs to be pulled down to disconnect the runners.

1

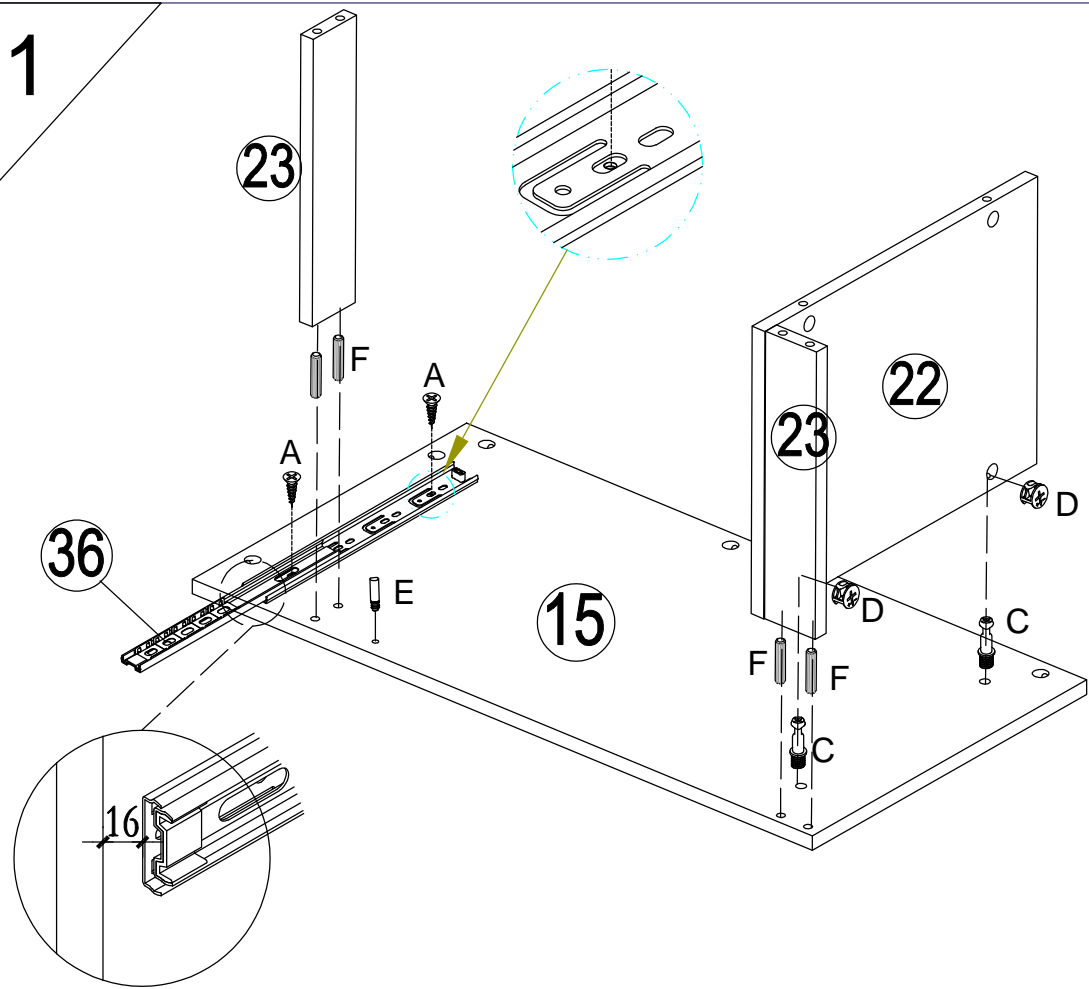

A	M3.5x12	C	M5x25	D	Ø15x10	E	M5	
	X 2		X 2		X 2		X 1	
F	Ø8x40							
								X 4

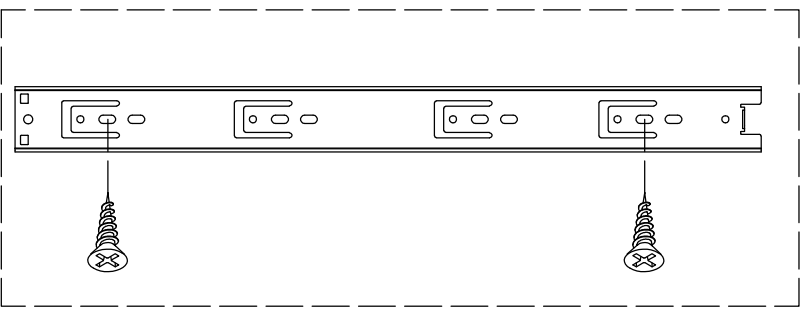
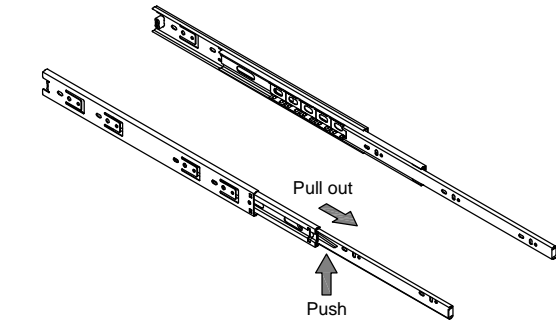

2

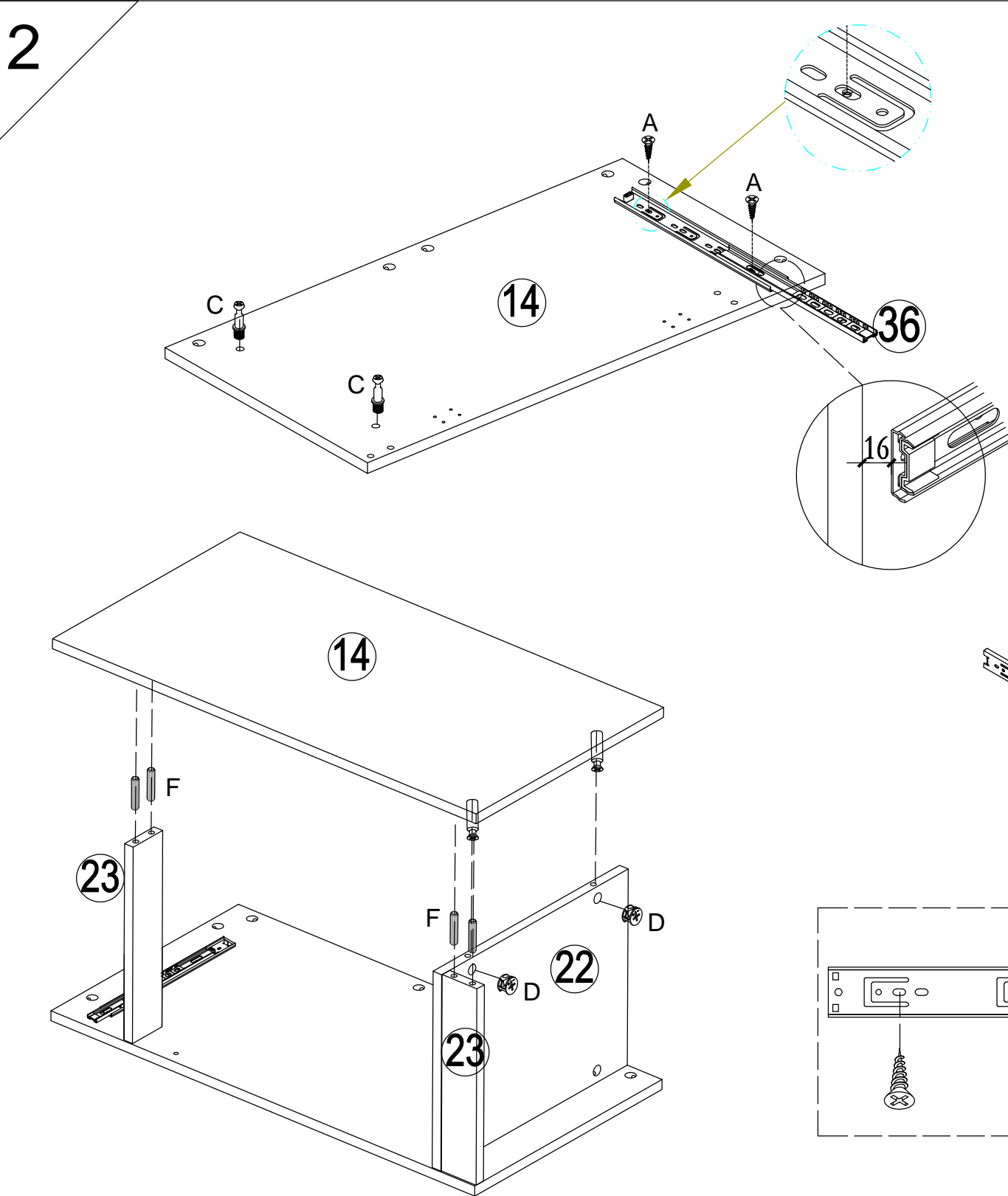

A	M3.5x12	C	M5x25	D	Ø15x10	F	Ø8x40
	X 2		X 2		X 2		X 4

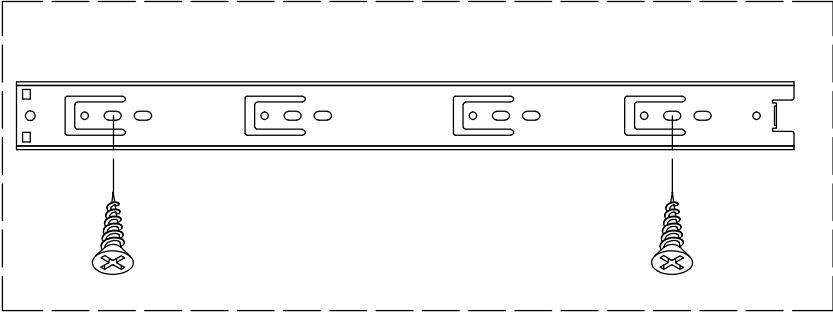
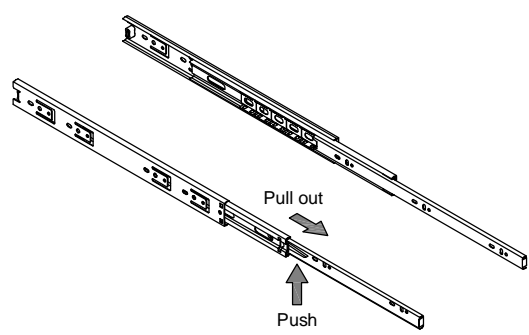

3

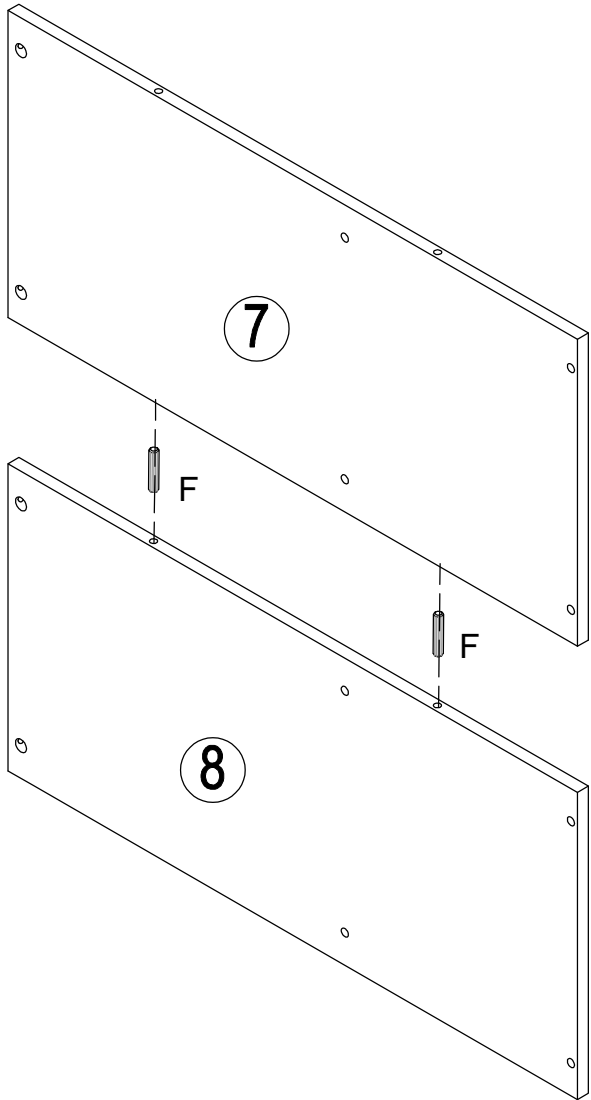

F Ø8x40
X 2

4

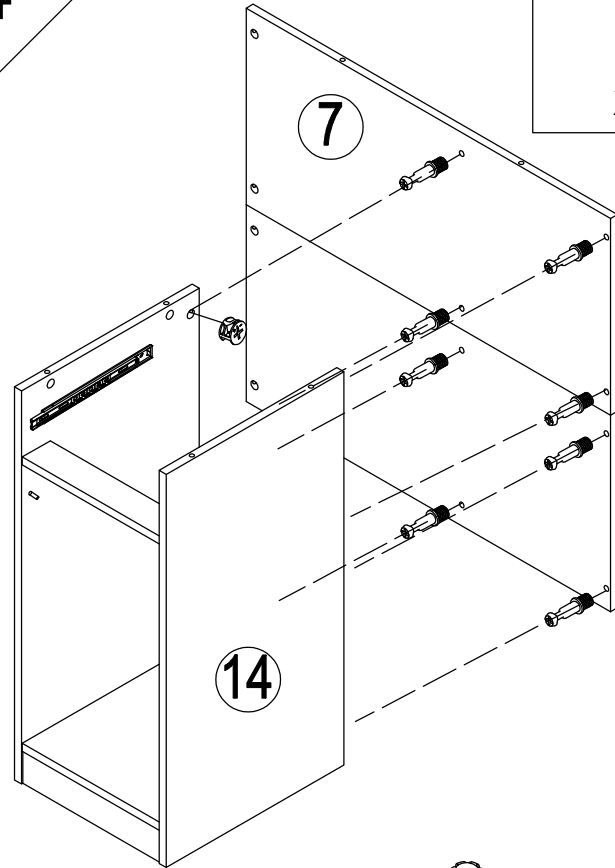

C M5x25
X 8

D Ø15x10
X 8

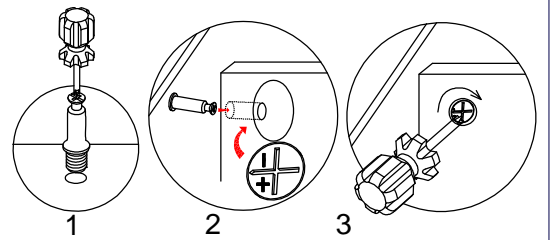

5

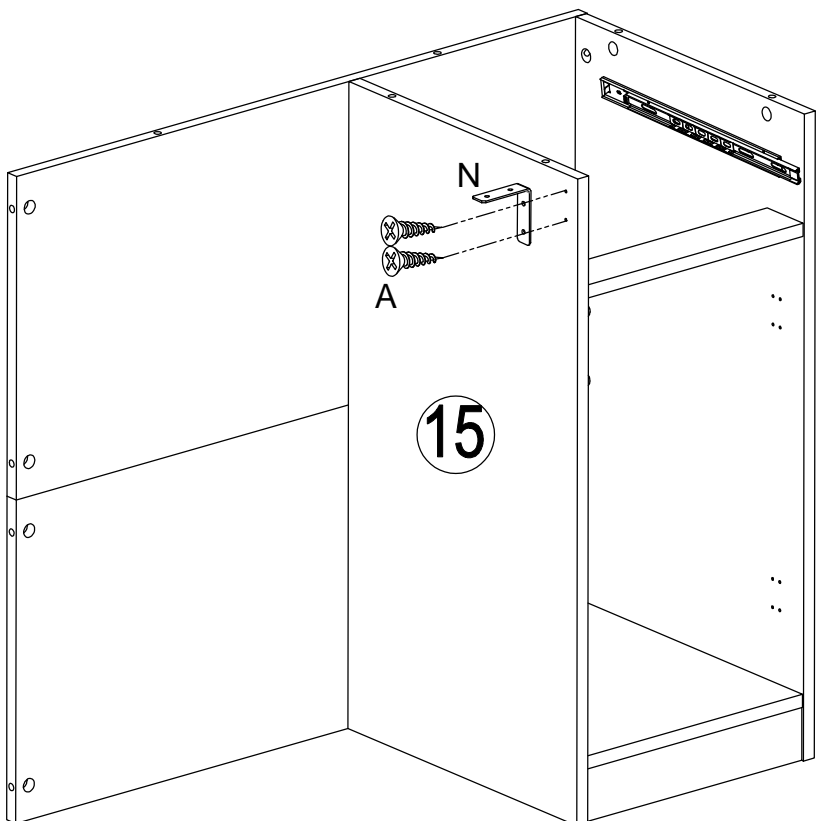

N
X 1

A M3.5x12
X 2

6

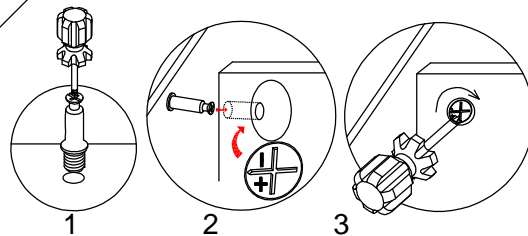

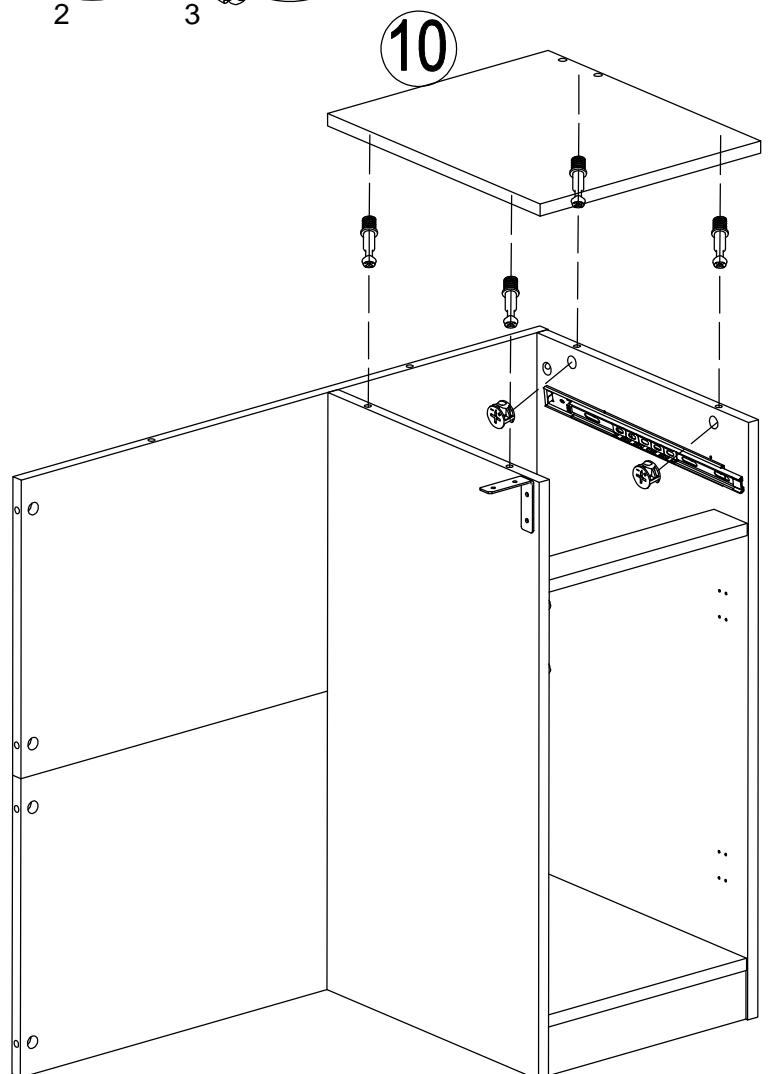

C M5x25
X 4

D Ø15x10
X 4

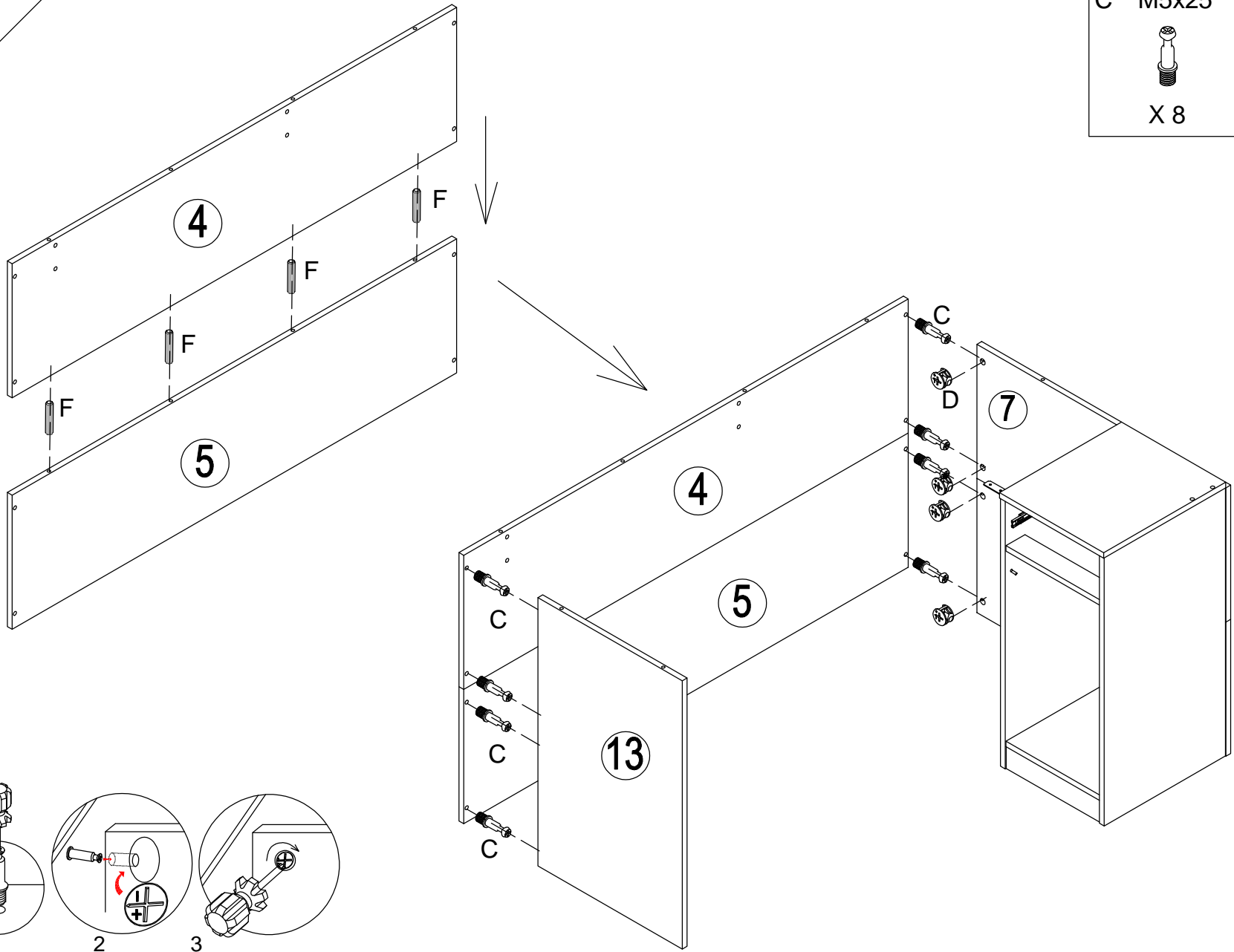

7



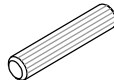

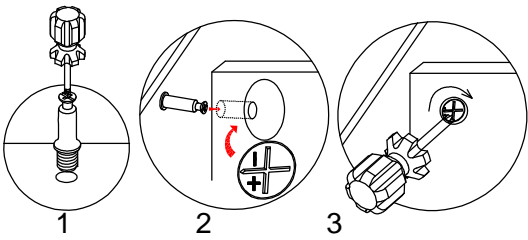
C M5x25  X 8	D Ø15x10  X 8
	F Ø8x40  X 4

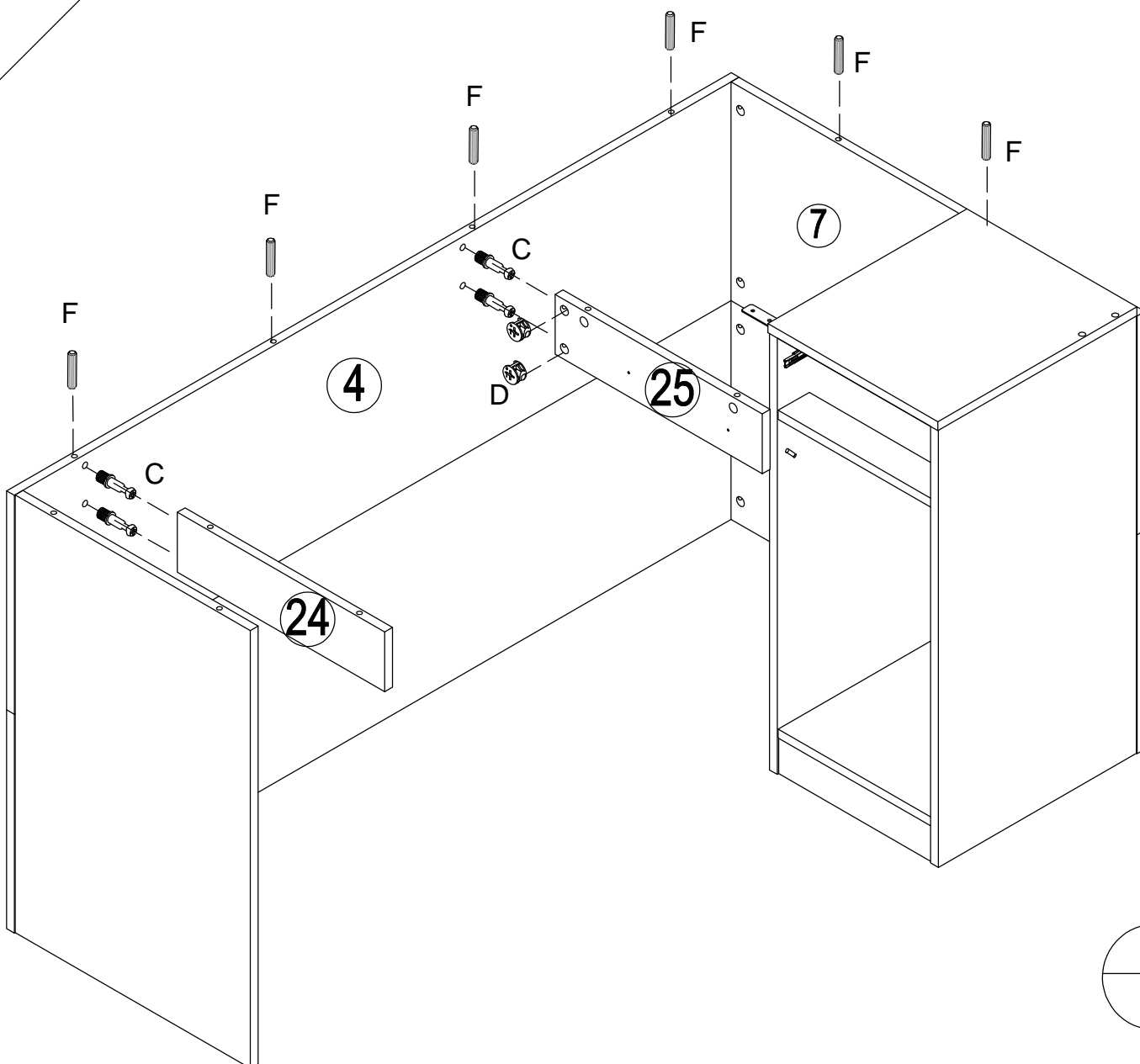

8



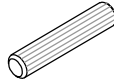

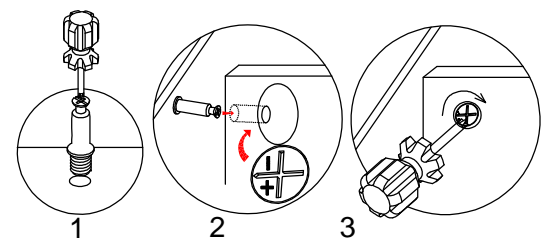
C M5x25  X 4	D Ø15x10  X 4
	F Ø8x40  X 6

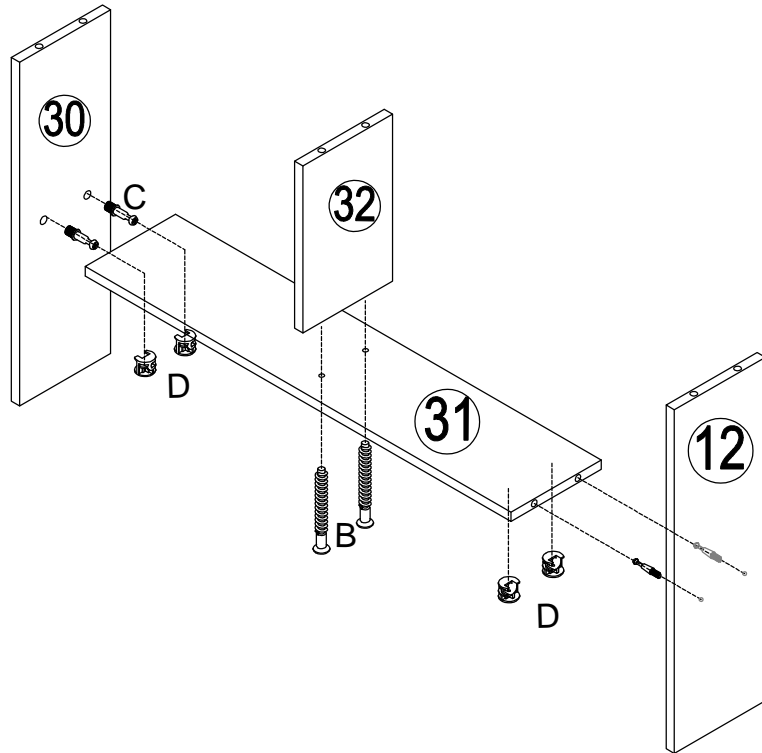

9

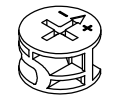

C M5x25  X 4	D Ø15x10  X 4
	B M5x40  X 2

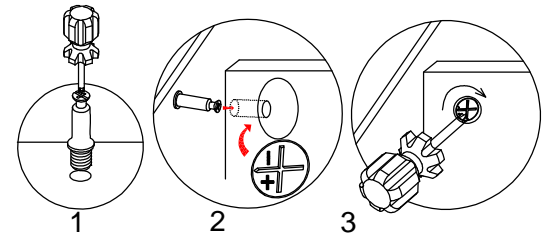

10

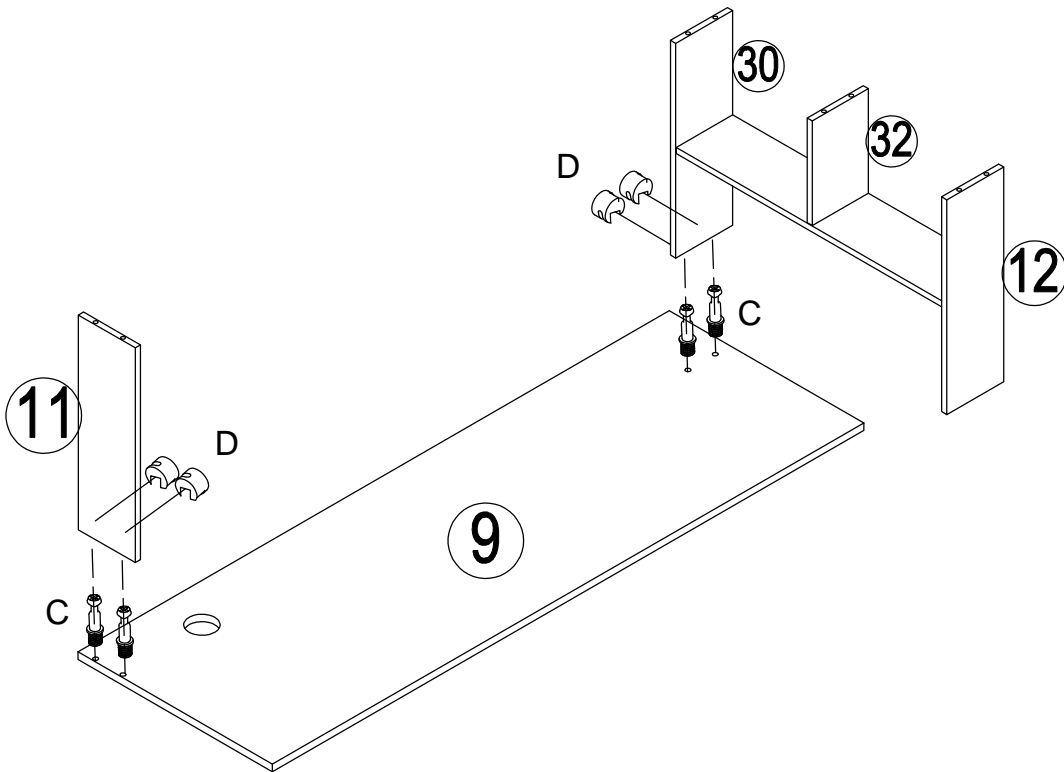

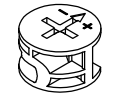
C M5x25  X 4	D Ø15x10  X 4
---	--

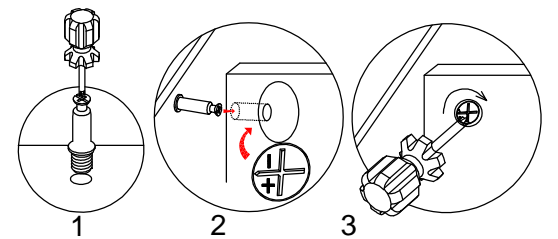

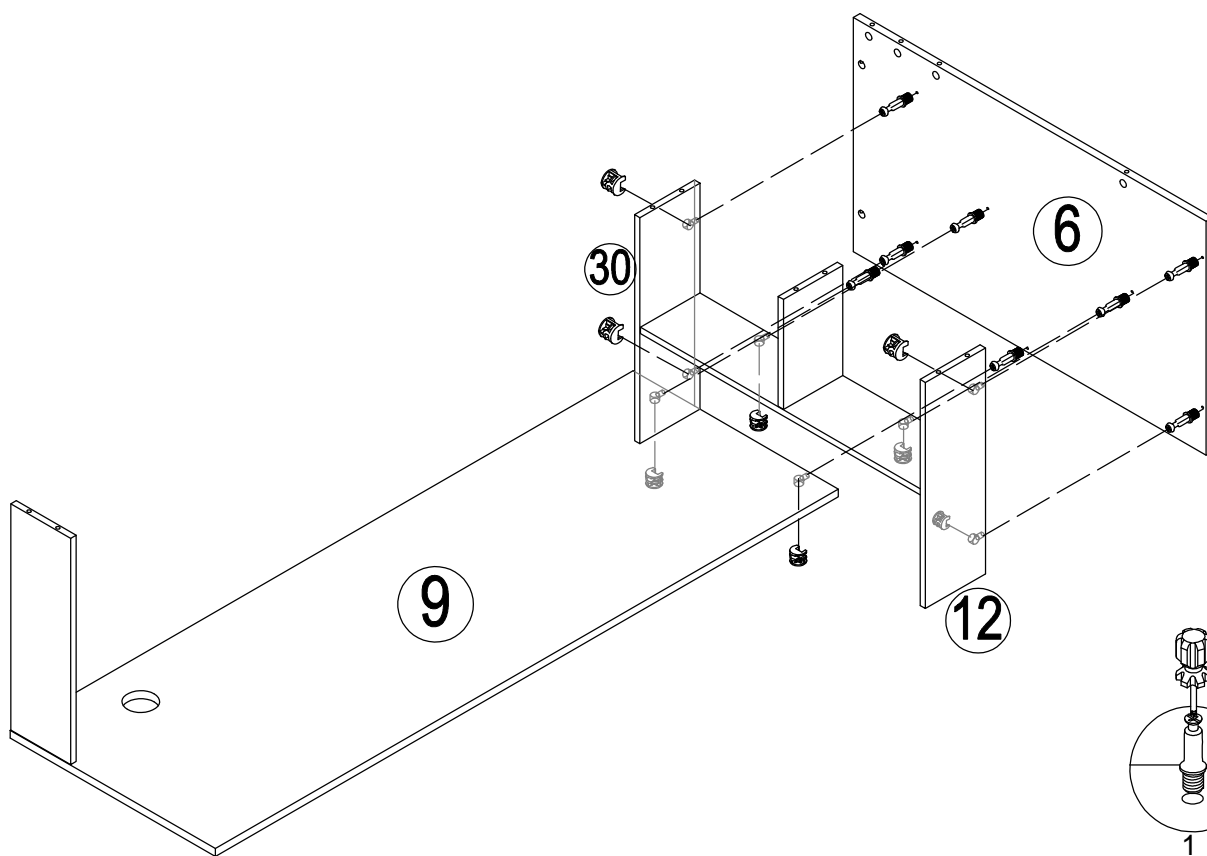

11

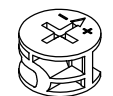

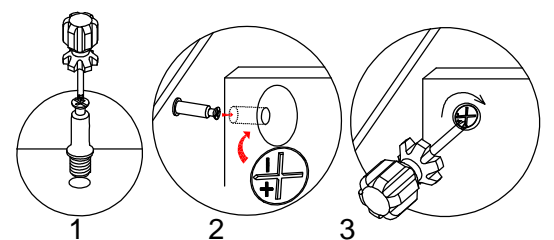
C M5x25  X 8	D Ø15x10  X 8
---	--



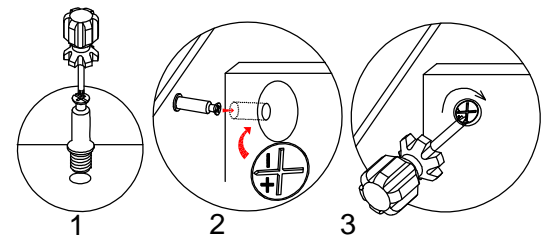
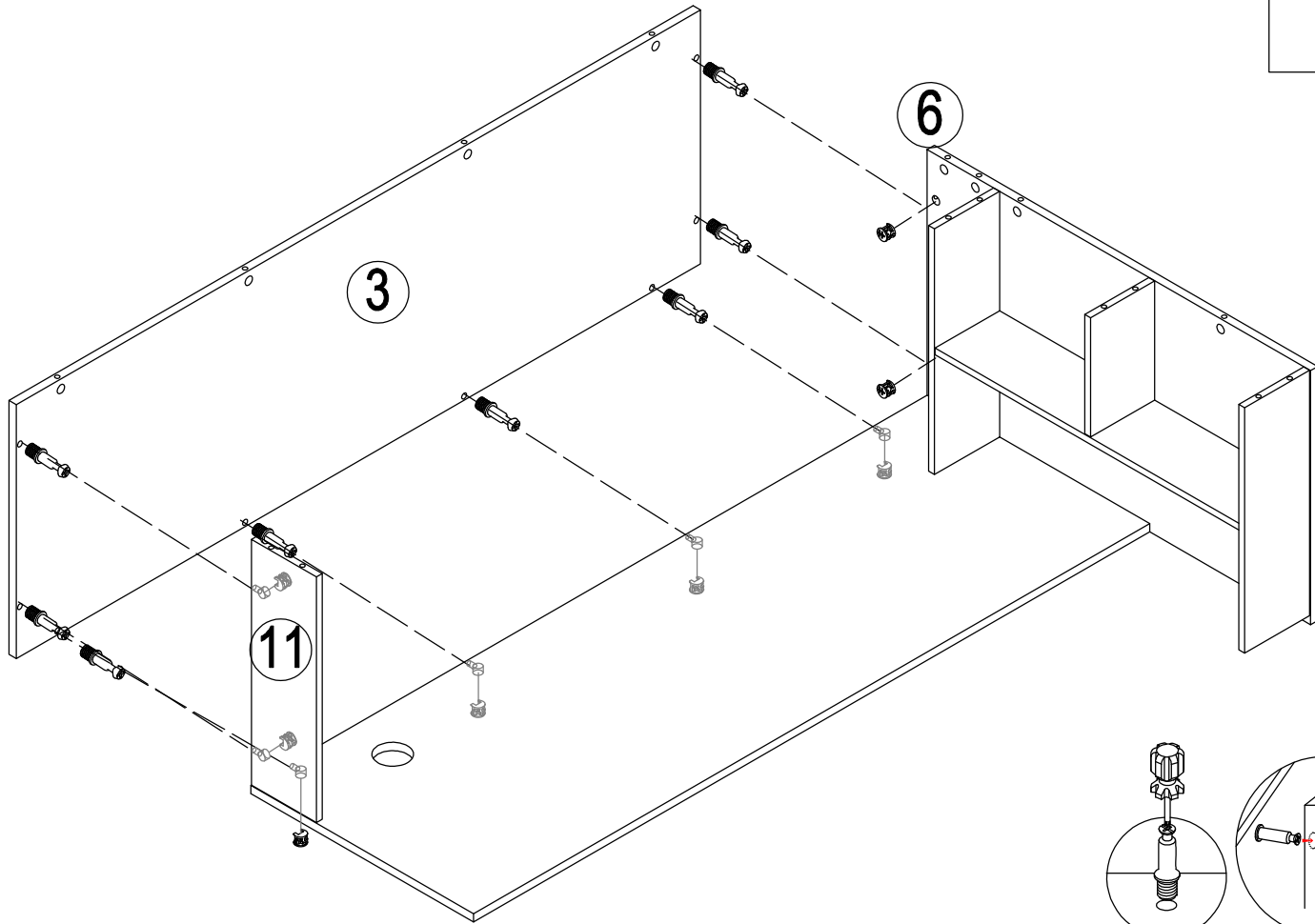

12

C	M5x25	D	Ø15x10
			
	X 8		X 8



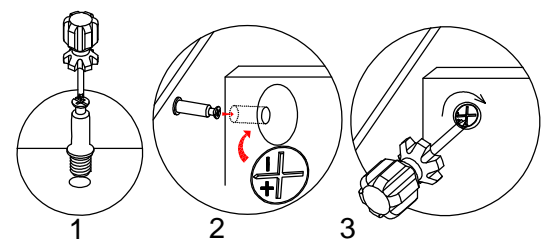
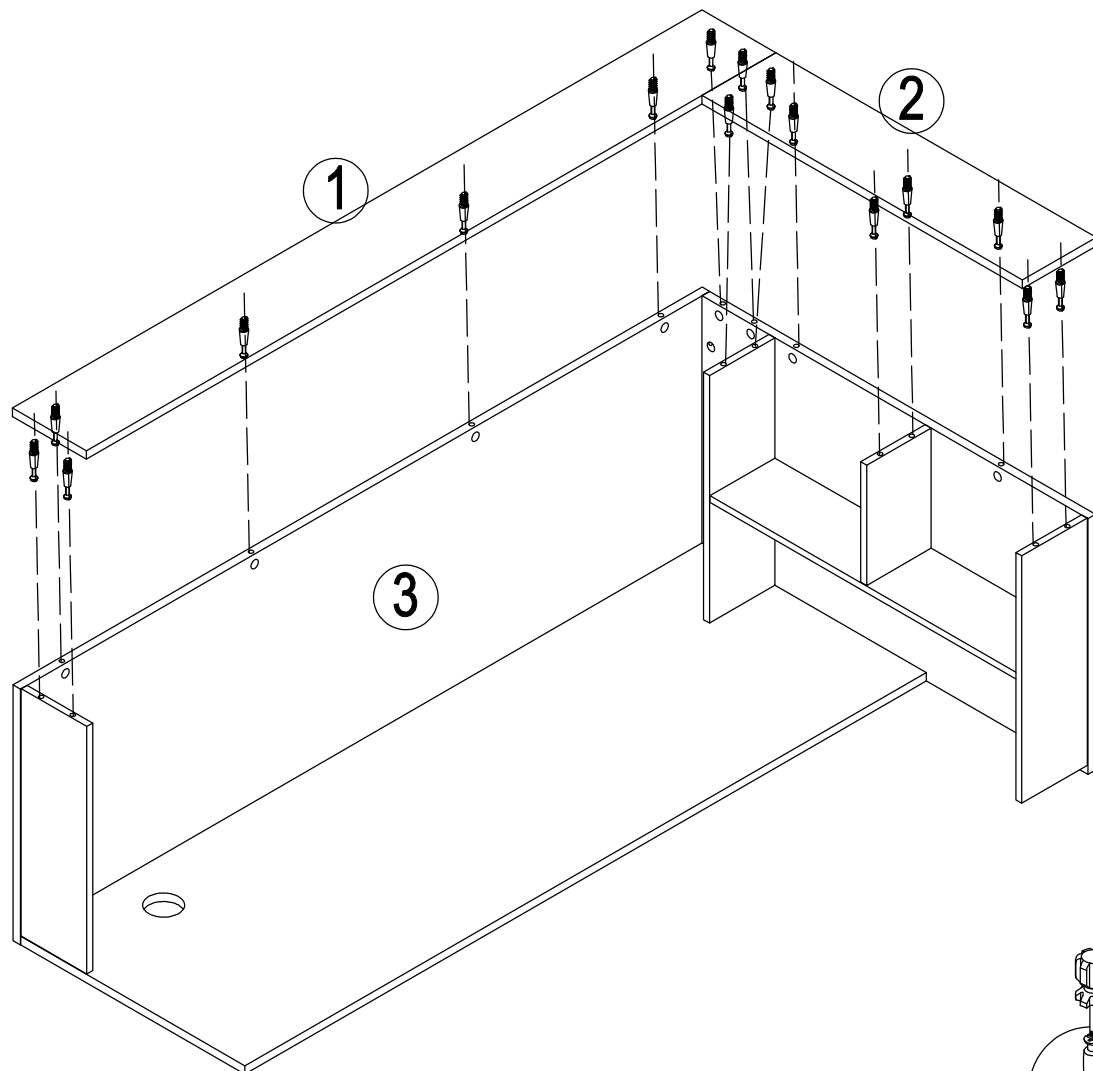

13

C	M5x25	D	Ø15x10
			
	X 16		X 16

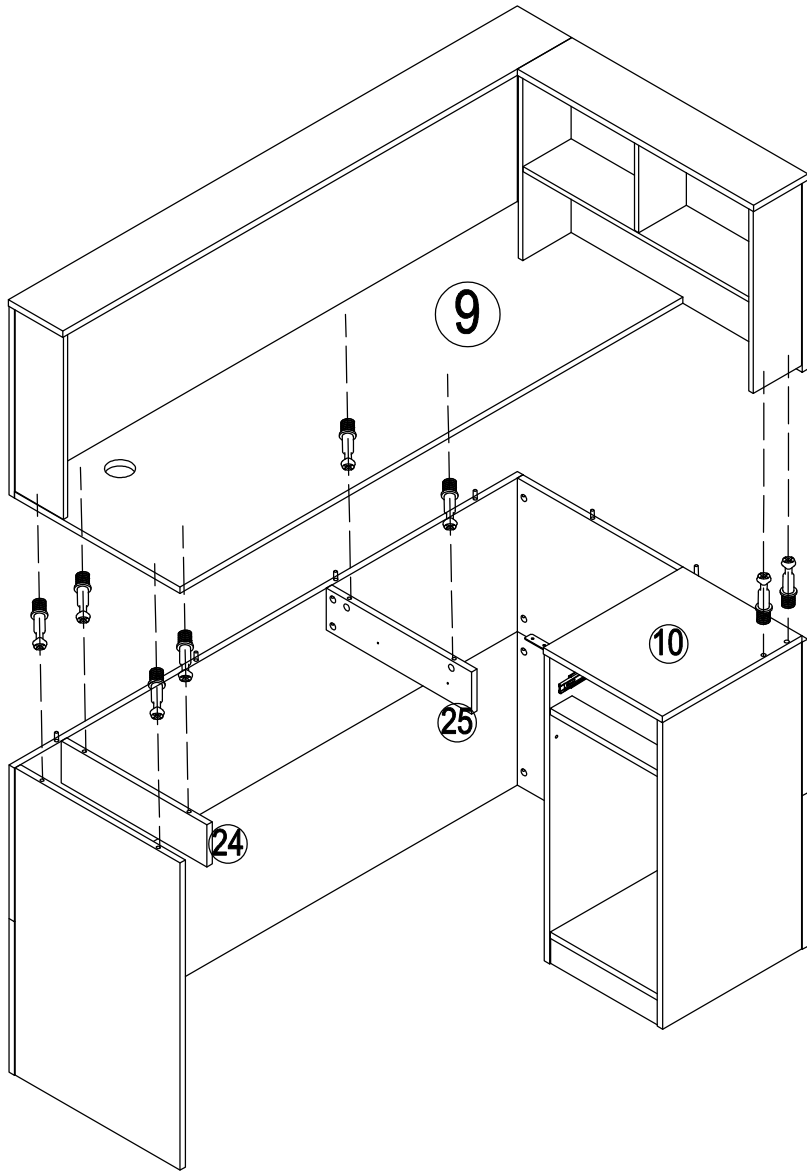

14



C	M5x25	D	Ø15x10
			
	X 8		X 8

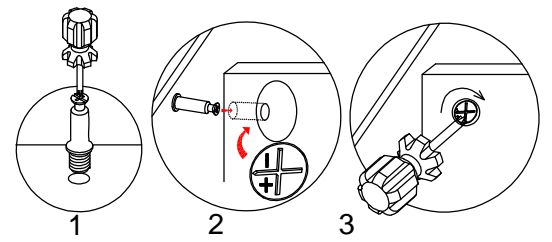
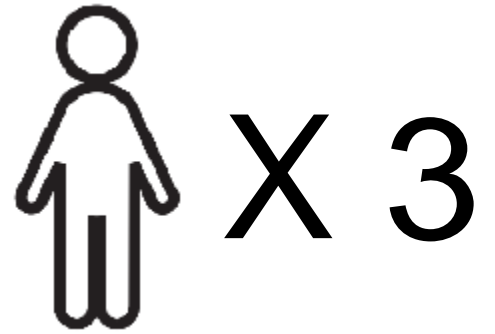

15

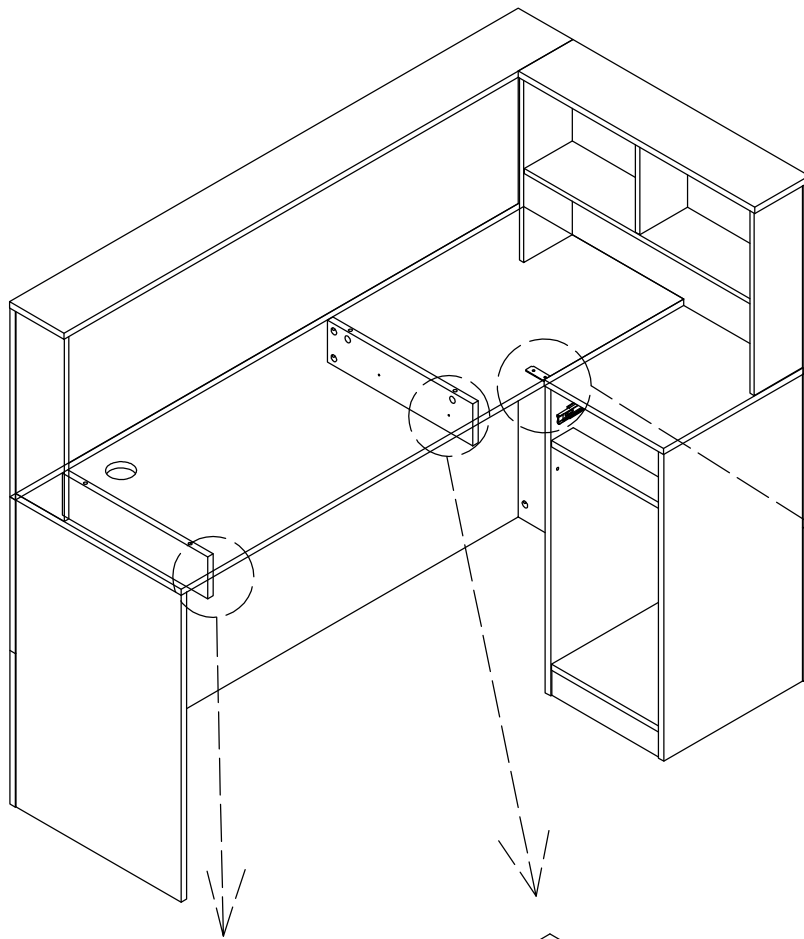
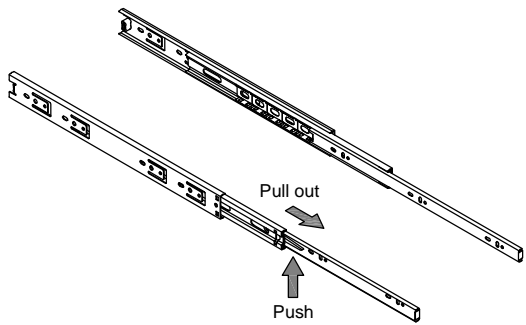

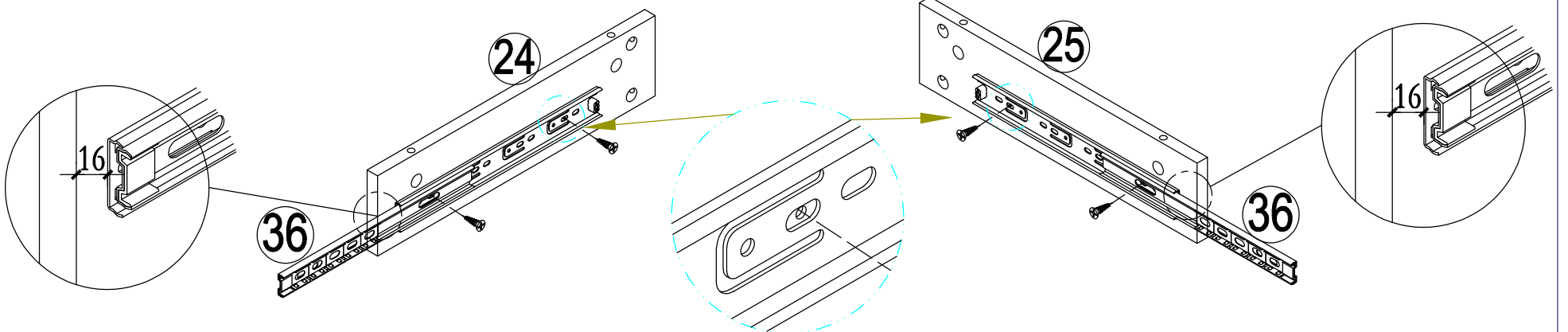

A	M3.5x12
	
	X 6

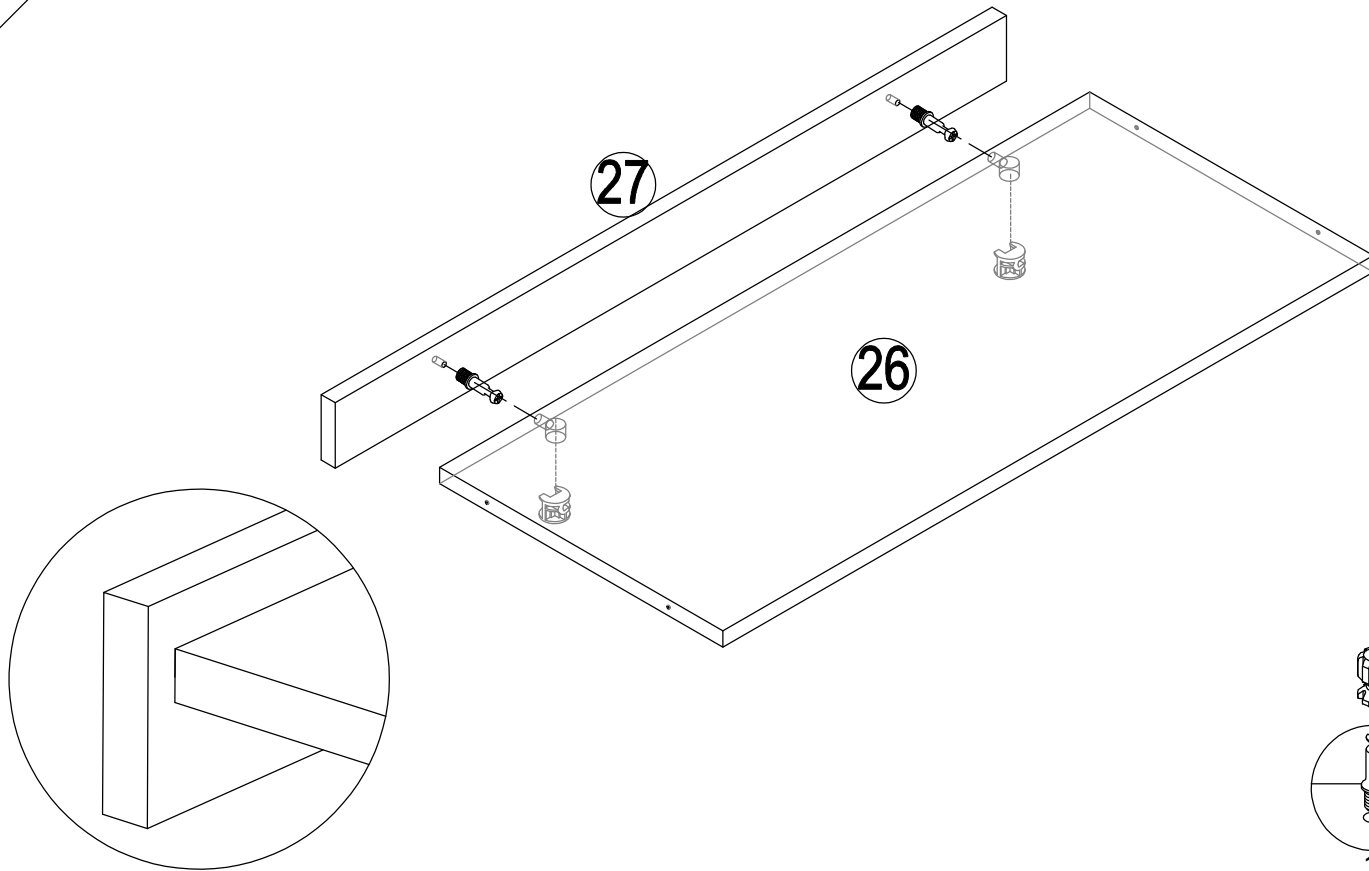

16



C	M5x25	D	Ø15x10
			
	X 2		X 2

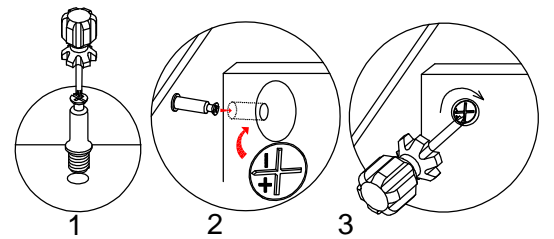

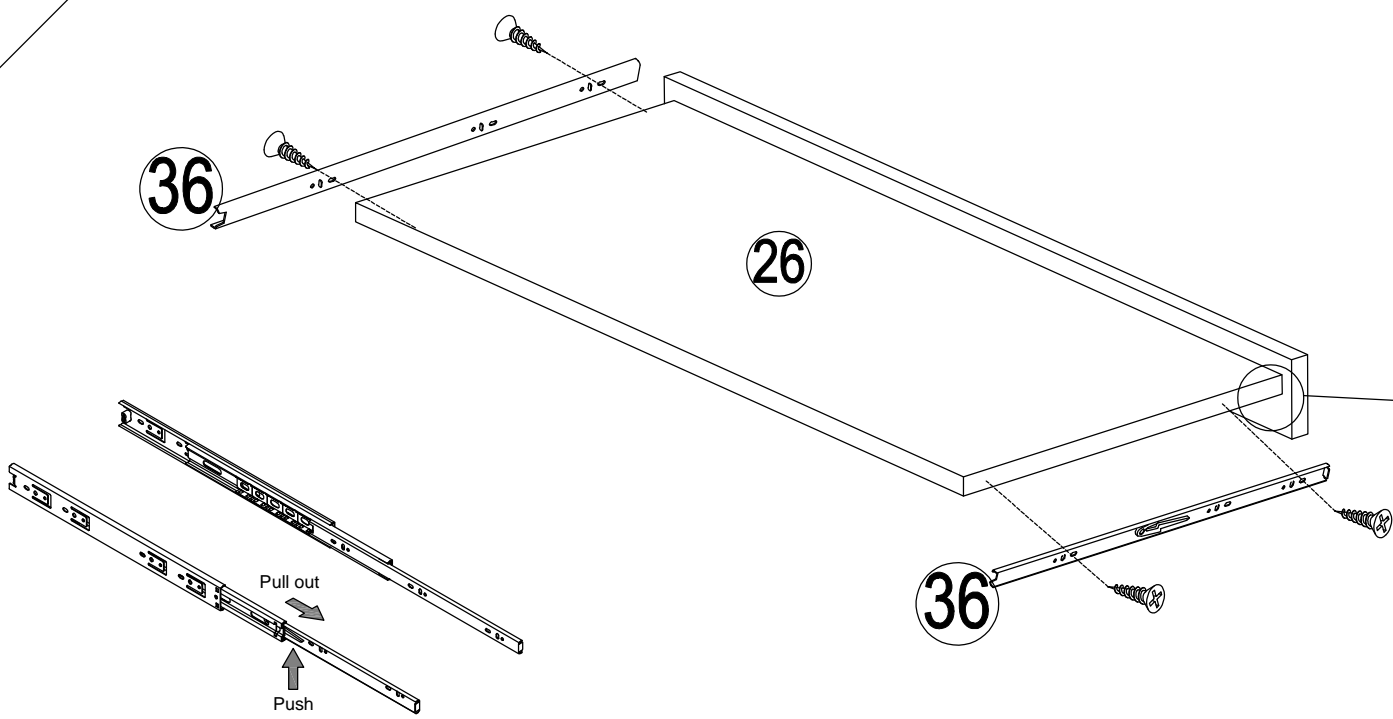

17

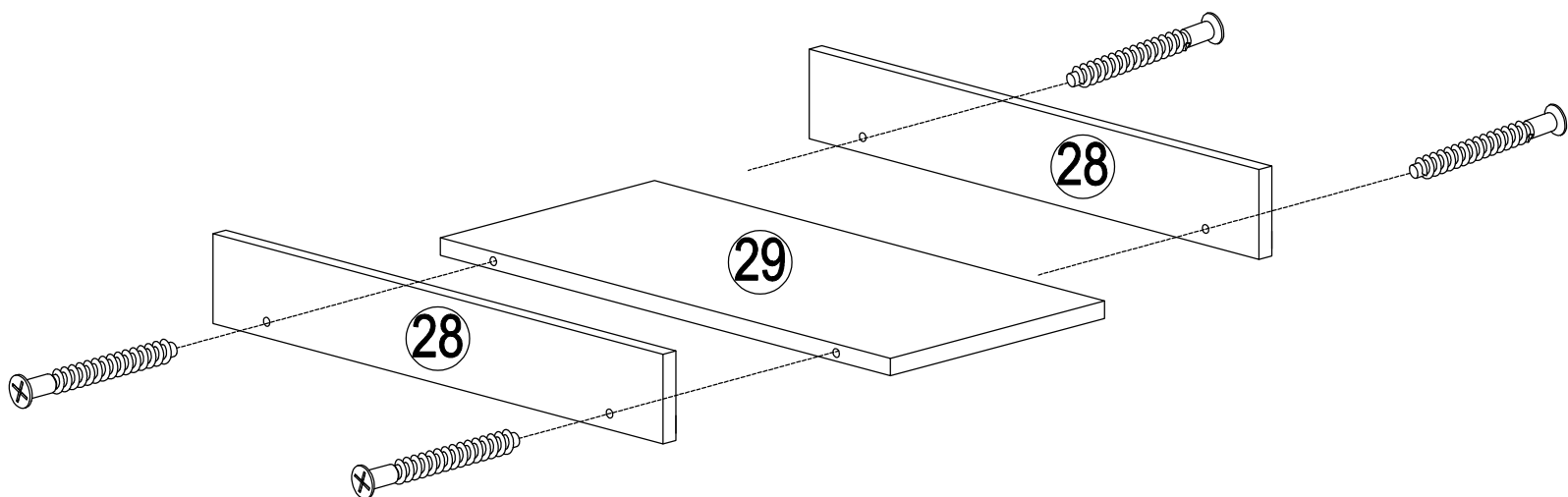

A	M3.5x12
	
	X 4

18



B	M5x40
	
	X 4

19

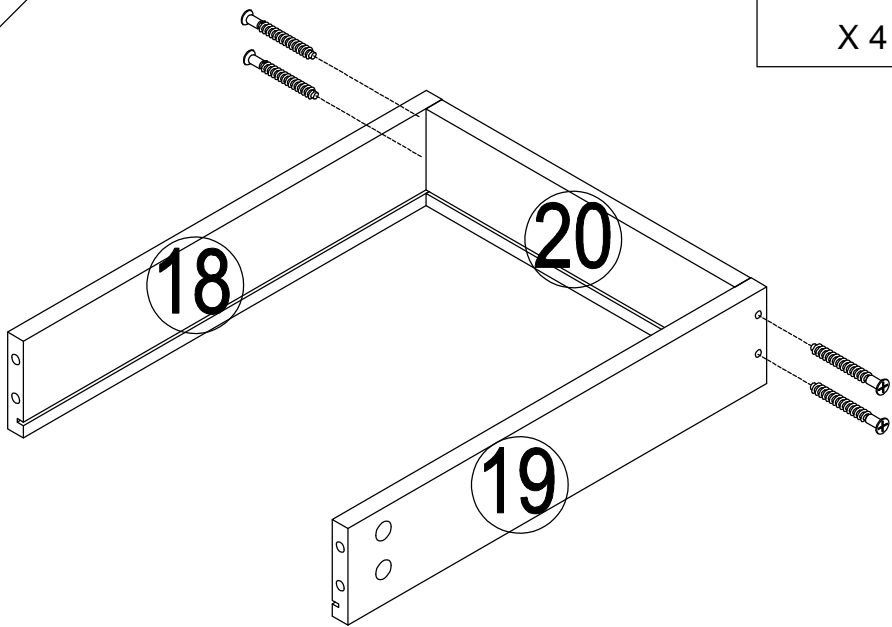

B M5x40

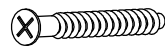

X 4

20

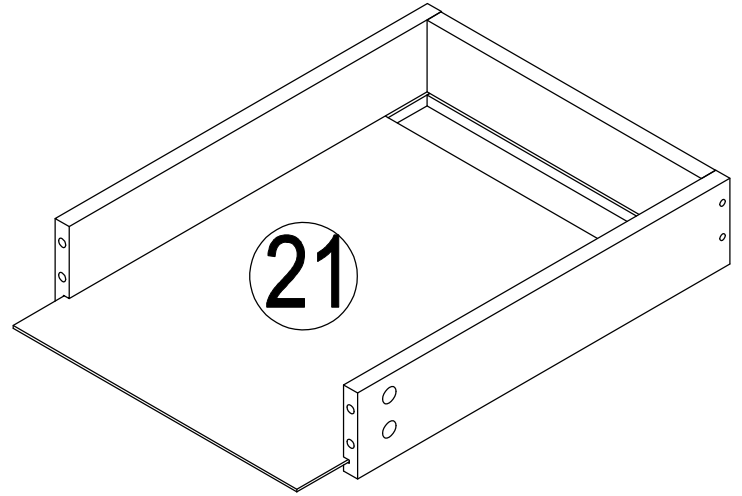

21

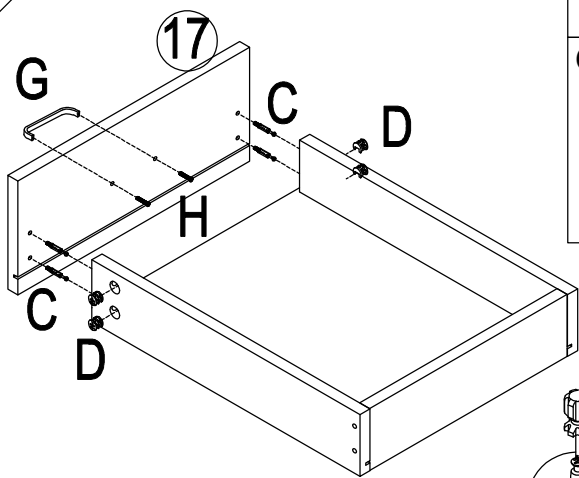

C M5x25



X 4

D Ø15x10



X 4

G M4x96

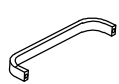

X 1

H M4x18

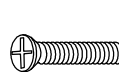

X 2

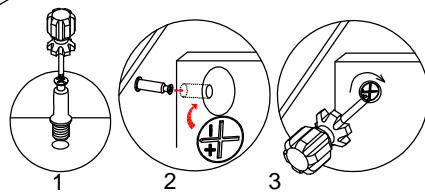

22

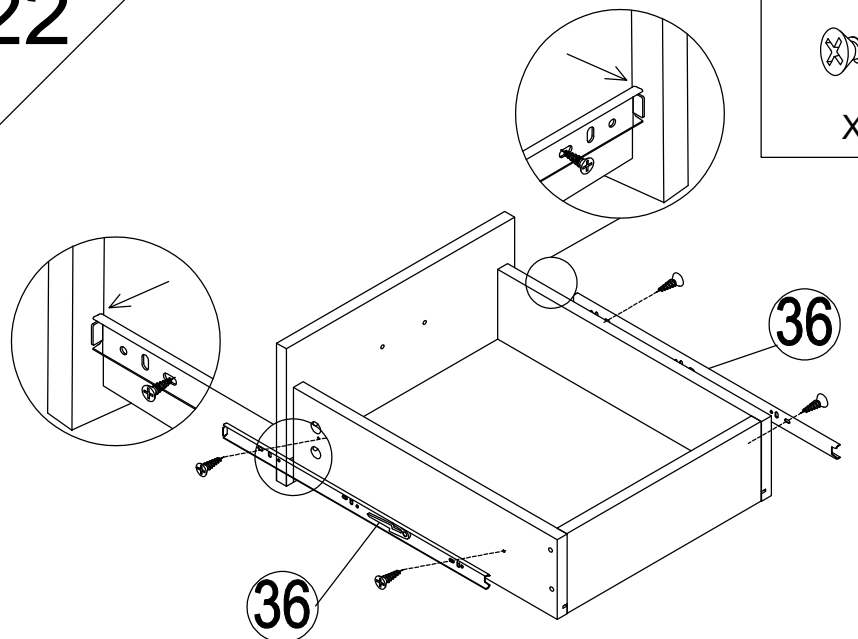

A M3.5x12

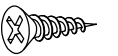

X 4

23

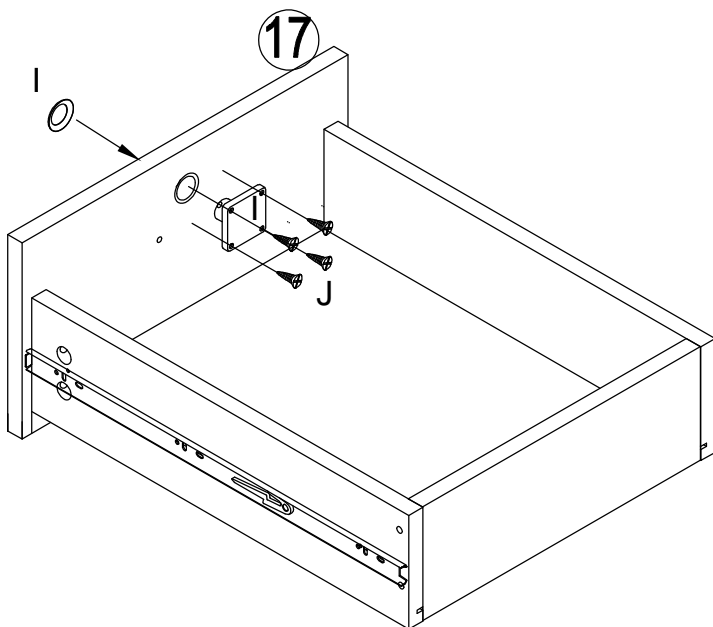

I



X 1

J M3x18





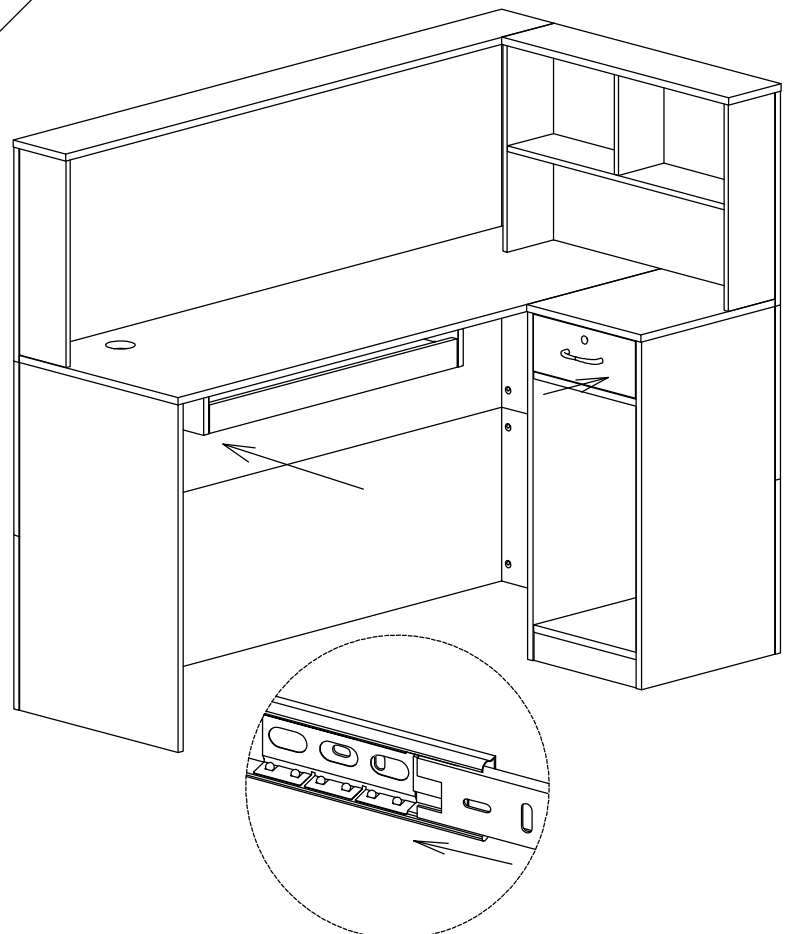

X 4

24

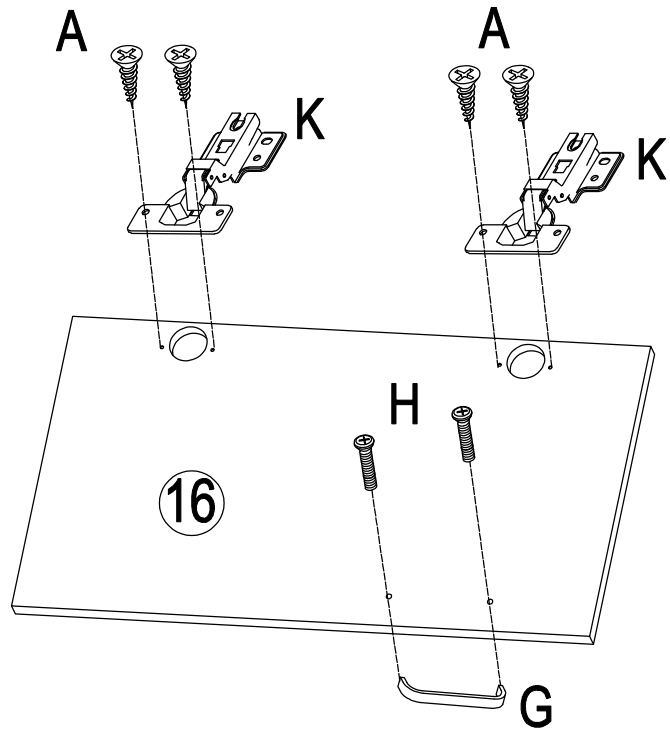

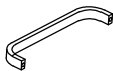

25

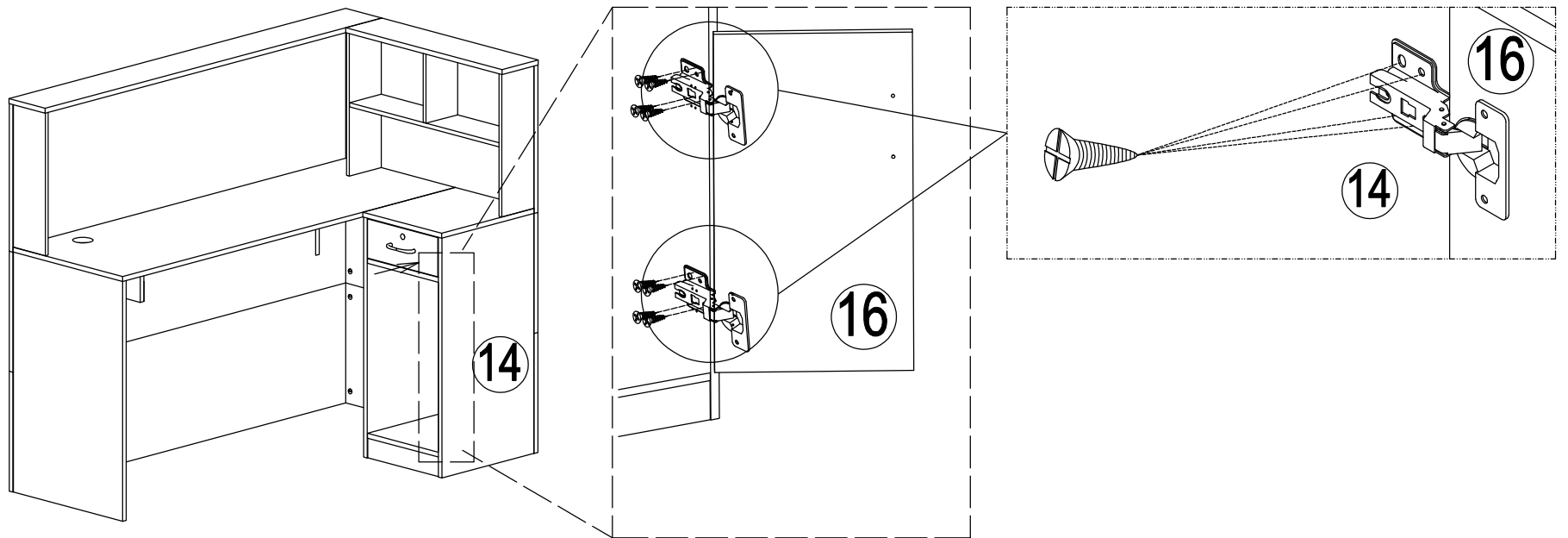

G M4x96  X 1	H M4x18  X 2	A M3.5x12  X 4
K DW  X 2		

26



A M3.5x12  X 8

27

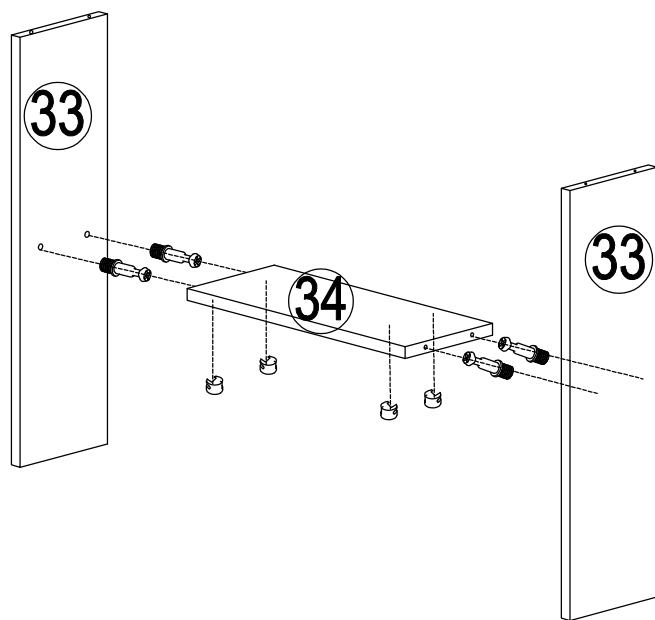

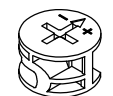
C M5x25  X 4	D Ø15x10  X 4
---	--

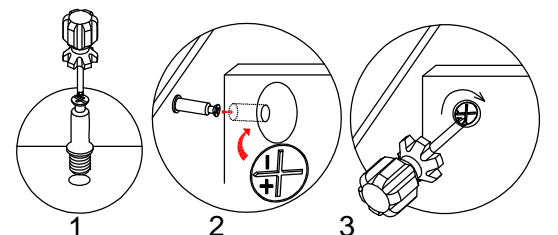

28

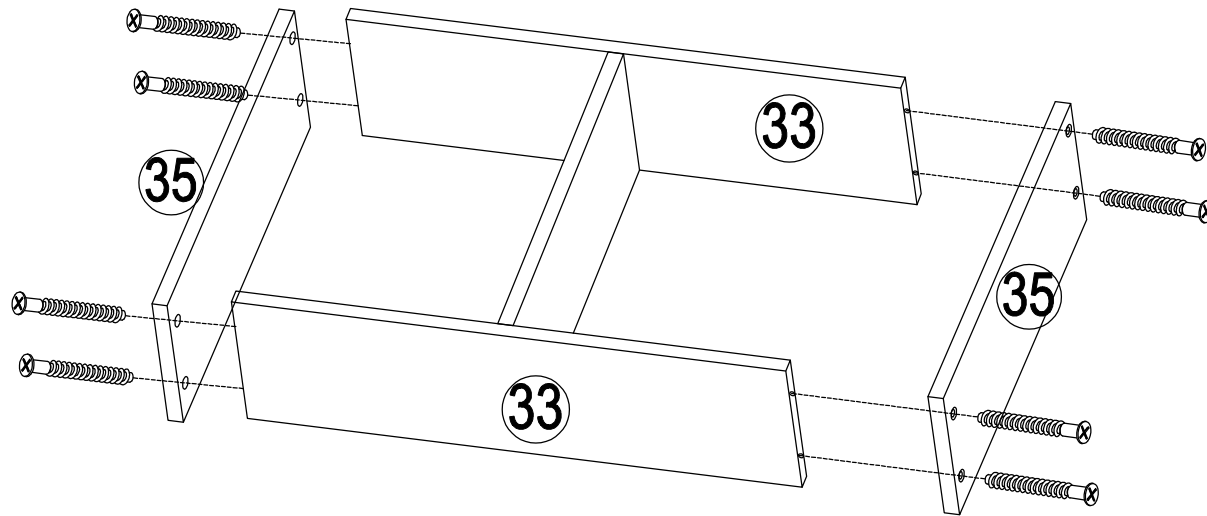

B M5x40



X 8

29

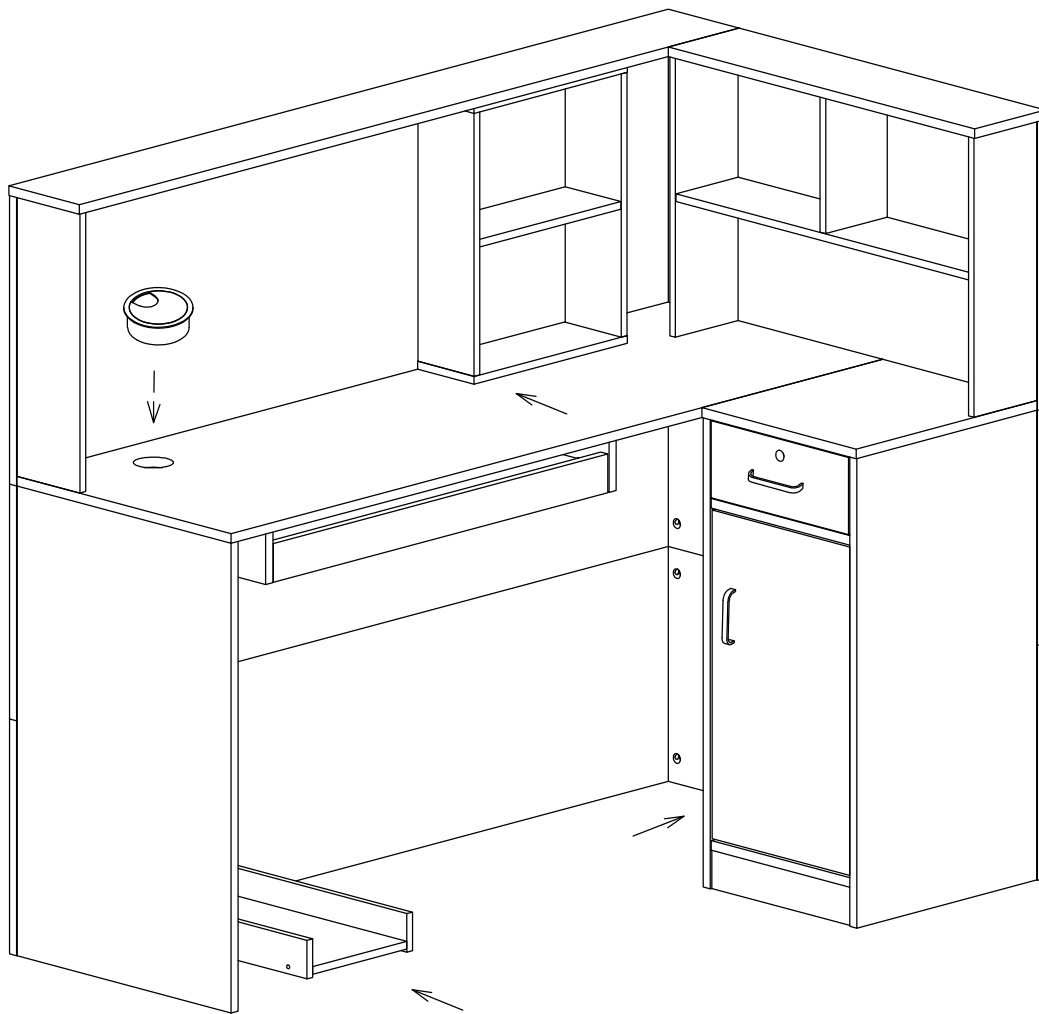

L Ø60



X 1

M



X 20

