

Table of Contents

Important Safety Instructions.....	1
Instructions.....	3
Parts List.....	4
Wall Oven Installation.....	7
How To Use.....	12
Cleaning & Maintenance.....	17
Troubleshooting.....	19
Warranty.....	20

IMPORTANT SAFETY INSTRUCTIONS

WARNING: To reduce the risk of fire, electrical shock, injury to persons, or damage when using the oven, follow basic precautions, including the following:

- Proper Installation – Be sure the oven is properly installed and grounded by a qualified technician.
- Never Use the Oven for Warming or Heating the Room.
- Do Not Leave Children Alone – Children should not be left alone or unattended in area where oven is in use. They should never be allowed to sit or stand on any part of the oven.
- Wear Proper Apparel – Loose-fitting or hanging garments should never be worn while using the oven.
- User Servicing – Do not repair or replace any part of the oven unless specifically recommended in the manual. All other servicing should be referred to a qualified technician.
- Storage in Oven – Flammable materials should not be stored in an oven.
- Do Not Use Water on Grease Fires – Smother fire or flame or use dry chemical or foam-type extinguisher.
- Use Only Dry Potholders – Moist or damp potholders on hot surfaces may result in burns from steam. Do not let potholder touch hot heating elements. Do not use a towel or other bulky cloth.
- Use Care When Opening Door – Let hot air or steam escape before removing or replacing food.
- Do Not Heat Unopened Food Containers – Build-up of pressure may cause container to burst and result in injury.
- Keep Oven Vent Ducts Unobstructed.
- Placement of Oven Racks – Always place oven racks in desired location while oven is cool. If rack must be moved while oven is hot, do not let potholder contact hot heating element in oven.
- DO NOT TOUCH HEATING ELEMENTS OR INTERIOR SURFACES OF OVEN – Heating elements may be hot even though they are dark in color. Interior surfaces of an oven become hot enough to cause burns. During and after use, do not touch, or let clothing or other flammable materials contact heating elements or interior surfaces of oven until they have had sufficient time to cool. Other surfaces of the oven may become hot enough to cause burns – among these surfaces are oven vent openings and surfaces near these openings, oven doors, and windows of oven doors.

For self-cleaning ovens:

- Do Not Clean Gasket – The gasket is essential for a good seal. Care should be taken not to rub, damage, or move the gasket.
- Do Not Use Oven Cleaners – No commercial oven cleaner or oven liner protective coating of any kind should be used in or around any part of the oven.
- Clean Only Parts Listed in Manual.
- Before Self-Cleaning the Oven – Remove broiler pan and other utensils.

When you first turn on the oven, you may notice a strong, unpleasant odor. This is caused by the adhesive used on the insulation boards around the oven heating up for the first time, and it is a normal occurrence. If you experience this, it's important to be patient and wait until the smoke dissipates before placing any food in the oven. Additionally, never roast or bake anything directly on the oven base, as this could damage the appliance.

Good Habits of Safety Awareness

- This device is designed for non-professional home use, and its functions should not be changed at will.
- The electrical system of this equipment can only be used safely if it is properly connected to a standard grounding.
- The manufacturer is not responsible for any damage caused by incorrect installation or unreasonable use of the equipment.

The following items are potentially dangerous and appropriate measures must be taken to keep children and the disabled out of the reach:

- Controls and general appliances;
- Package, such as bags, polystyrene, nails, etc;
- Electrical appliances when they are no longer in use, especially potentially hazardous parts.



Warning: Accessible parts become hot during use. To avoid burns and scalds, keep children away. The product will become hot in use, attention should be taken to avoid touching the heating elements in the oven.

Avoid the Following Situations:

- ❖ The wet body comes into contact with the appliance.
- ❖ Using the appliance when barefoot.
- ❖ Pull the appliance or power cord to unplug it from the power outlet.
- ❖ Block ventilation or cooling slots.
- ❖ Allow power supply cords of small appliances to contact with the hot parts of the unit.
- ❖ Exposing the appliance to atmospheric agents , like rain or sun.
- ❖ Use the oven as storage.
- ❖ Use flammable liquids near the appliance.
- ❖ Using adapters, multiple sockets or extension cords;
- ❖ Attempt to install or repair equipment without the assistance of qualified personnel.



Important: Do not use harsh abrasive cleaners or sharp metal scrapers to clean glass door, as they will scratch the surface to shatter.

Electric Wall Oven

Model: EB-80ERC-8BC85II







Introduction

Parameter Specifications

Dimensions	Cut Out	Voltage/ Frequency	Material	Capacity	Rated Power	Max Temp	Timer
23.4''L*23.4'' W''*21.5''H	22.05''L*23.19 W''*21.65''H	208-240V 60Hz	Stainless Steel finish+Tempered Glass door	2.8 cu. ft	2420- 3220W	480°F	120 Mins

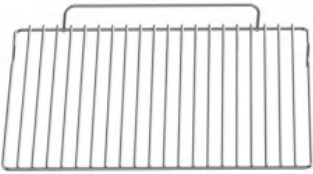
The oven runs on a single-phase alternating current with a voltage of 208-240V and a frequency of 60Hz. It is important to check the nameplate specifications affixed to the machine before installing the equipment to ensure it is compatible with your power supply.

Parts List

Parts	Number	Picture
Tray	1pcs	
Large Grill	1pcs	
Small Grill	1pcs	
Rotisserie Fork	1pcs	
Pull Handle	1pcs	
Manual	1pcs	<div style="text-align: center;"> <p data-bbox="1102 1637 1235 1671">Electric Wall Oven Model: EB-SHERC-SBC6III</p>  <p data-bbox="1098 1850 1251 1861">Viklo home User Instructions</p> <p data-bbox="1070 1868 1273 1899"><small>Thank you for purchasing this home range. Please read the instructions carefully and obey all safety messages. If you have any questions, please do not hesitate to contact our service team: info@viklohome.com</small></p> </div>

Power of the Heating Tube & Light

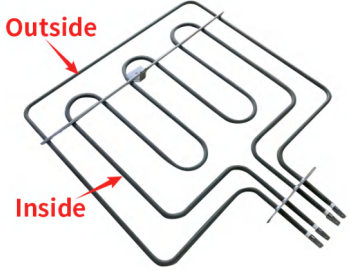
Lower Heating El.	1200W	
Circle Heating El.	2100W	
Total Upper Heating El.	1000W+1900W	
Upper Inside Heating El.	1900W	
Upper Outside Heating El.	1000W	
Oven Light	15W	/

Power of the Heating Motor

Synchronmotor	4W	
Shaded Pole	25W	
Exhaust Blower	15W	

A qualified electrician must be contacted in the following cases:

- ❖ Install according to the instructions;
- ❖ When you are unsure about operating the equipment;
- ❖ The power socket needs to be replaced when it is not compatible with the electrical plug.

Service Center authorized by the manufacturer must be contacted in the following:

- ❖ If there is any doubt about the integrity of the device after it has been removed from the packaging;
- ❖ If the power cord is damaged or needs to be replaced;
- ❖ If the equipment occurs to malfunctions or operates abnormally, you need to ask for original spare parts.

Useful tips about using oven:

- ❖ Only use the appliance to cook food instead other;
- ❖ Check the condition of the appliance after it has been unpacked;
- ❖ Before cleaning or performing maintenance, if the device is not operating properly, unplug it from the power source;
- ❖ Turn off and unplug oven when it's not in use for a long time;
- ❖ Remove the cookware from the oven by cooking pull handle or gloves;
- ❖ Always grasp the oven door in the centre because the ends may be hot due to the escape of hot air;
- ❖ Make sure the control knob is at the "o" setting when the device is not in use;

Wall Oven Installation

IMPORTANT: Unplug your oven before performing installation or maintenance. Installation should be performed by a qualified professional according to the instructions. Please note that the manufacturer is not take responsible for any damage to persons, animals or objects resulting from incorrect installation.

Opening Dimensions (General tolerance)

Width: 22.05 +/- 0.05"

Height: 23.19 +0-0.09"

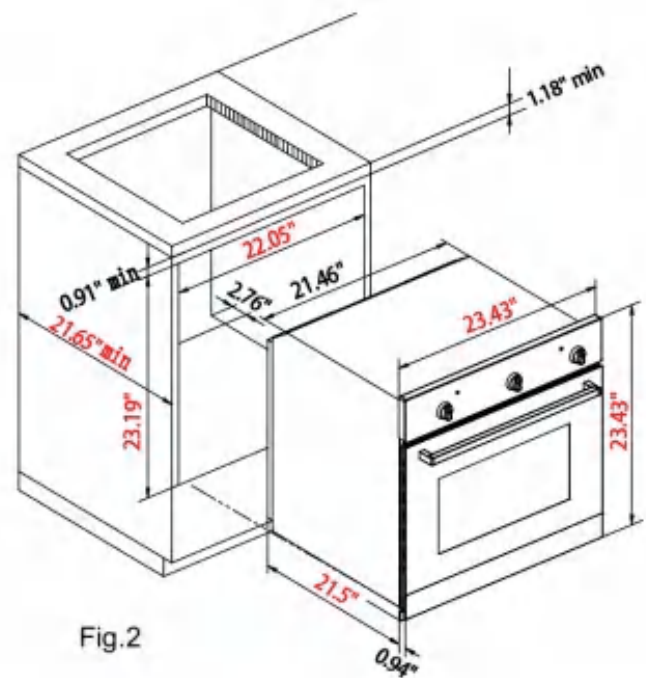
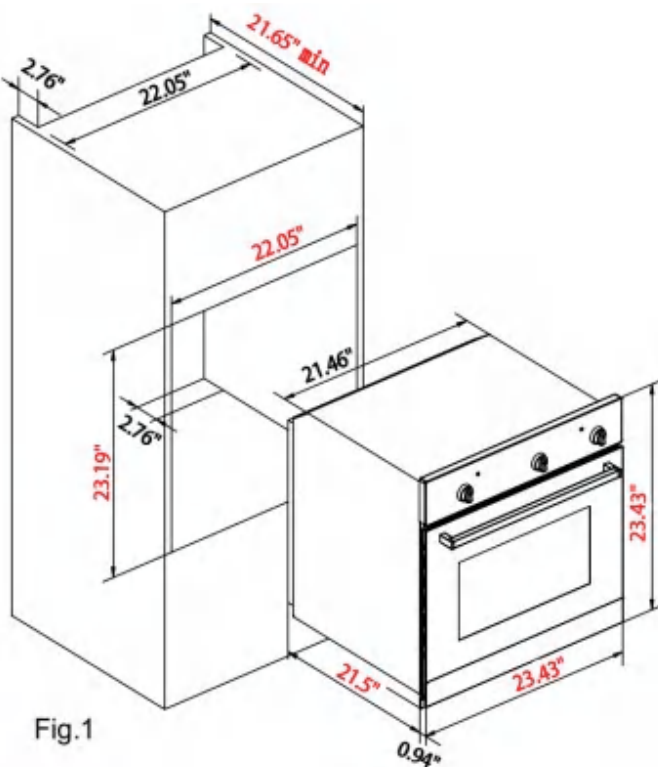

NOTE: When pairing the oven with a stovetop, it is important to carefully follow the instructions provided in the booklet accompanying the other appliance. Additionally, for efficient air circulation, the oven should be installed according to the recommended dimensions. (Fig. 1).

There are 2 holes in the door frame to mount the oven to other surroundings (under the bench or above other machines) by screwing and inserting the plastic cover (Fig. 3).

There should be at least 2.76'' (70 mm) of clearance behind the panel where the oven is installed (Fig.4-5).

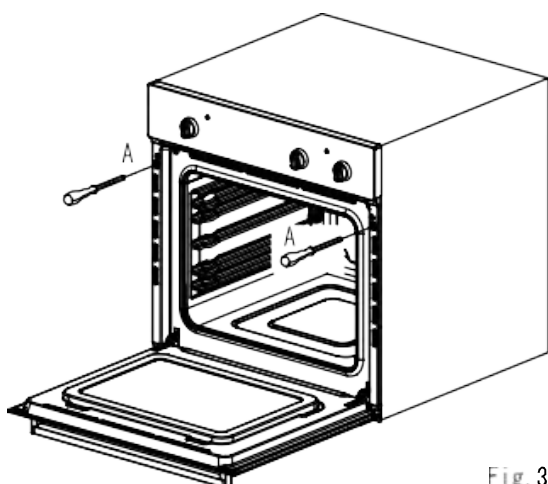

Fig.3

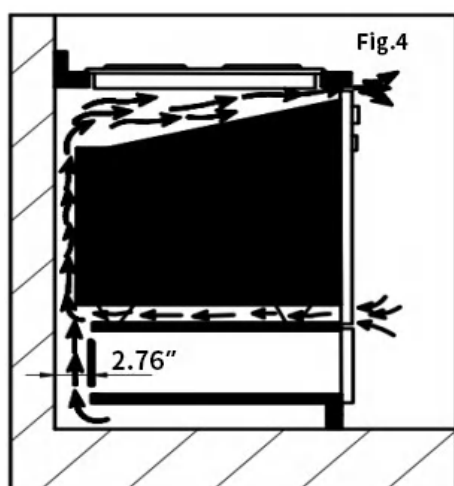
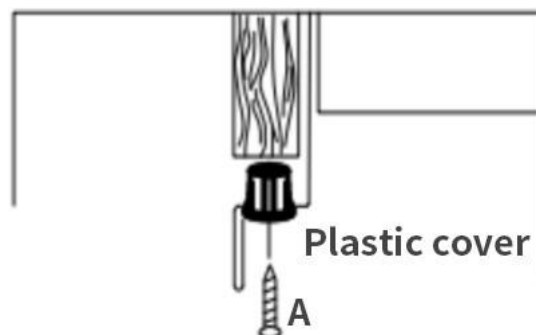

Fig.4

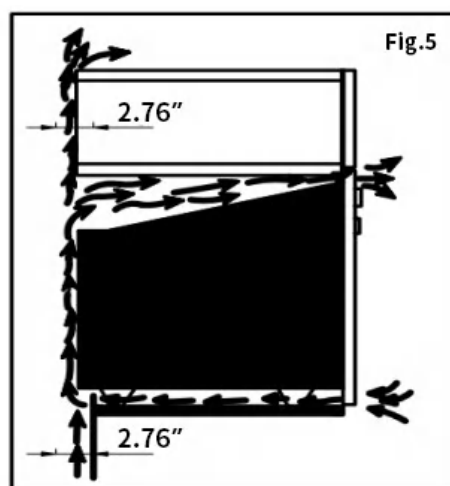

Fig.5

- ❖ To ensure proper functionality of a built-in oven, it's important to have the right type of cabinets in place. The adjacent furniture panels must be heat-resistant, particularly if they are made of wood veneers. The adhesive used should be able to withstand temperatures of at least 250°F (120°C) to prevent deformation or detachment. By taking these precautions, you can ensure your oven operates effectively and safely.
- ❖ For your safety, do not touch electrical components once the device is installed.
- ❖ All protective parts provided cannot be fixed in a non-removable way.

- ❖ Ensure the appliance is turned off before replacing the lamp to avoid the possibility of electric shock.

Connection to the Mains Supply

Devices must be connected according to current rules. It is recommended to be wired by a professional electrician.

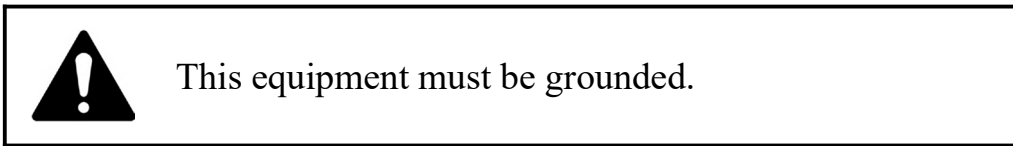

Check that the rated power of the power supply and outlet match the max wattage indicated on the nameplate. Additionally, it's crucial to make sure that you connect your appliance correctly by inserting the plug into a socket with a third contact point for grounding.

If the device has a power cord installed but no plug, wire it as follows:

- ❖ The “**Green**” grounded wire, which must be connected to the terminal, generally 0.39" (10mm) longer than other wires.
- ❖ If input voltage is 110V, you need to connect both black and white wires to live line to get 220V; If you already have junction box in kitchen can offer 220V, check another wiring.
- ❖ The green wire should connect to both the neutral and ground lines for proper grounding.
- ❖ Mains connection can also be made by fitting a double pole switch with a min gap between the contacts of 0.12 inches (3mm), proportionate to the load.

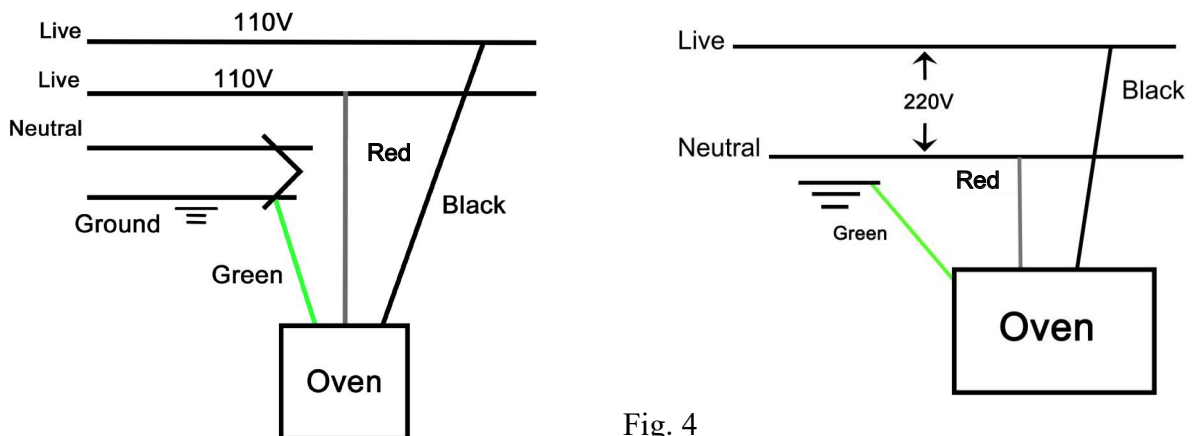

Fig. 4

- ❖ Once the appliance is in place, the plug or two-pole switch for the mains connection should be handy.

IMPORTANT

The power cord should be placed 120°F (50°C) below the ambient temperature. Safety can only be ensured if it is properly connected to a valid grounded power source in accordance with electrical safety regulations. The manufacturer is not responsible for any damage to persons or objects due to lack of a ground connection.

If a gas stove needs to be installed above the wall oven, the distance between them should be **> 1.58"**.

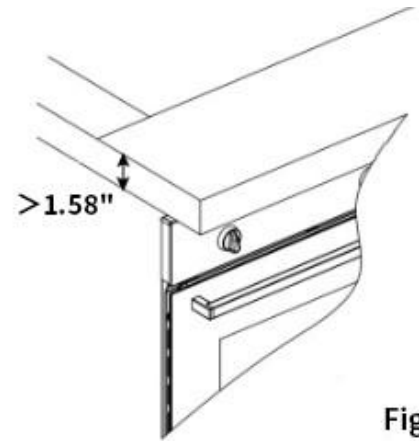

Fig.6

Removable Glass Door

The oven door consists of three layers of glass, with each layer having a flow-through top and bottom. During operation, air circulates through the door to prevent the outer pane from becoming hot. If condensation occurs between the glass panes, the door can be removed for cleaning purposes.

To remove the door, follow the instructions above and place it on a protective surface like a tablecloth to prevent scratches. Ensure that the door handle lines up with the table's edge and that the glass lies flat to prevent breakage during cleaning.

1. Press the buttons on the left and right sides of the door and remove the top rail (Fig.7).
2. Slowly remove the inner glass (Fig.8).
3. Loosen the clips (Fig.9).
4. Remove the middle glass (Fig.10).

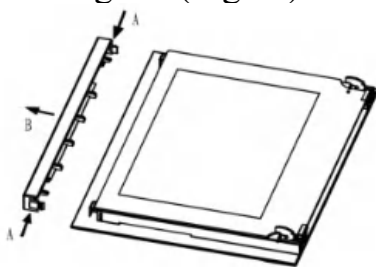

Fig.7

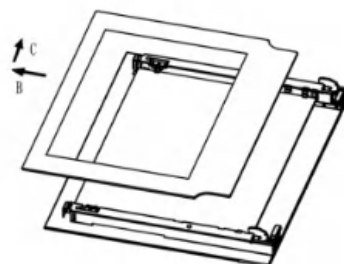

Fig.8



Fig.9

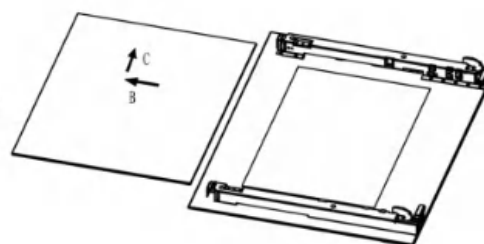

Fig.10

Clean the glass and other parts using a damp microfiber cloth, a clean sponge, or a hot water solution with a small amount of detergent. Dry everything with a soft cloth.

Disassemble/Assemble the Oven Door

To make it easier to clean the oven, the oven door can be removed as below steps:

- ❖ Open the door completely and lift the 2 levers “B” (Fig.11);
- ❖ Shut the door slightly, you can lift it out by pulling out the hooks “A” to reassemble the door. (Fig.12)
- ❖ When door is in a vertical position, insert the two hooks “A” into the slots;
- ❖ Ensure that seat “D” is hooked perfectly onto the edge of the slot (Move the oven door backwards and forward slightly)
- ❖ Keep the oven door open fully, unhook the 2 levers “B” downwards and then shut the door again.

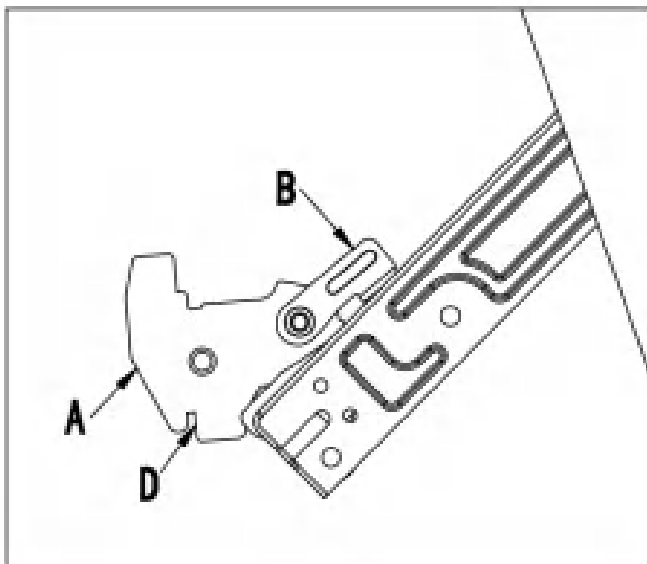

Fig.11

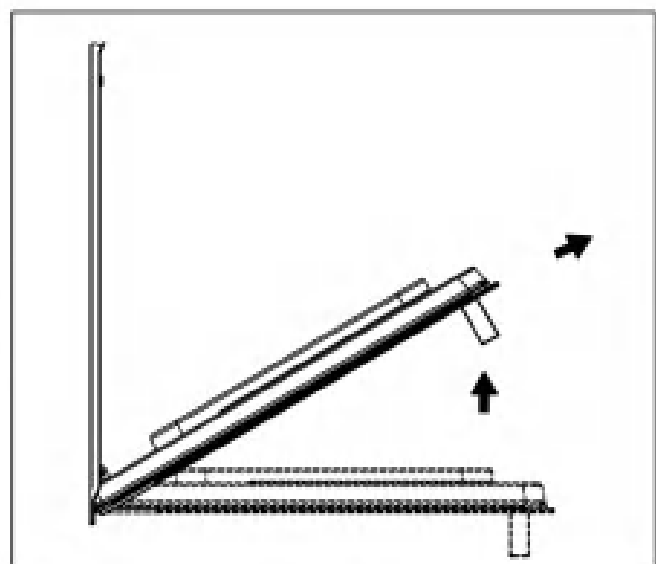
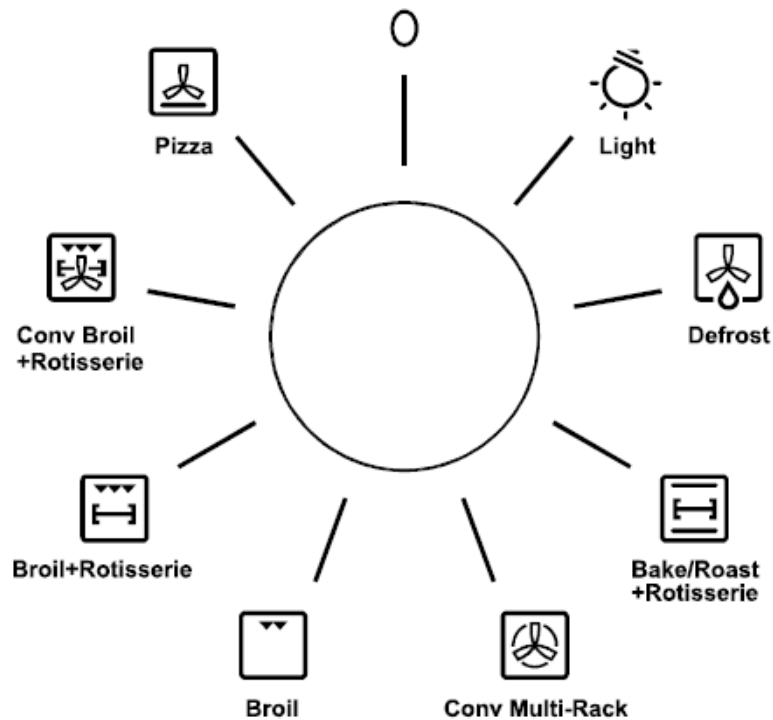

Fig.12

How To Use



About the Icon

Note: the inverted triangle represents the inside heating tube on the top



Circle Heating El.



Fan

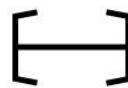

Rotisserie



Defrost



Upper Inside Heating El.



Upper Outside Heating El.











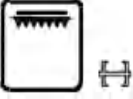

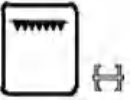

Lower Heating El.

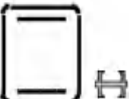

Upper Inside & Outside Heating El.

Note: the inverted triangle represents the inside heating tube in the top.

	<p>Defrost The air at ambient temperature is distributed inside the oven for defrosting food more quickly and without proteins adulteration.</p>
	<p>Broil+Rotisserie (All Upper heating element  or Rotisserie ). You can rotisserie the food in the broil function. Always broil with the door closed. In this mode, all upper heating element are working</p>
	<p>Broil+Rotisserie (Upper inside heating element  or Rotisserie ). You can rotisserie the food in the broil function. Always broil with the door closed. In this mode, only the upper inside heating tube is working.</p>
	<p>Convection Broil Convection broil is similar to broil. It combines intense heat from the upper element with heat circulated by a convection fan. This mode is well suited for cooking thick, tender cuts of meat, poultry and fish. It is not recommended for browning breads, casseroles and other foods. Always use convection broil with the door closed. Compare with standard broiling, convection broiling is faster.</p>
	<p>Proof+Rotisserie Maintains a low temperature for proofing bread or other yeast dough.</p>
	<p>Convection Bake Similar to Bake, but air is circulated by a fan at the back of the oven. Best for baked food such as cake, cornbread, pie, quick bread, tart, and yeast bread.</p>
	<p>Convection Multi-Rack Circulates heat uniformly using a fan and heating element in the back. This mode is well suited for cooking individual serving-sized foods such as cookies, biscuits, cream puffs, cupcakes, dinner rolls, and muffins, also good for cooking on multiple racks (2 or 3) at the same time.</p>
	<p>Bake/Roast+Rotisserie Bake: Cooks with dry, heated air; Perfect for cakes, cookies, pastries, quick bread, quiche and casseroles. Roast: Use more intense heat from the upper element and more browning of the exterior; Suit for meats, poultry, less tender cuts of meats and roasting vegetables</p>

	<p>Pizza Function Similar to Bake, but the air is circulated from a fan at the back of the oven that cycles on and off. All types of pizza- fresh, frozen, prebaked crust and ready-to-bake.</p>
	<p>Convection Broil Ideal for dishes that require top heat, such as rice pudding or cauliflower cheese because the heat is not as fierce as a grill.</p>
	<p>True Convection+Hot Air Economy This feature allows you to use the whole grill or just part of them for economical grilling in small quantities.</p>

Use the Rotisserie

In the icon "  " of the function panel, the rotisserie can be used in combination with the rack. After fitting the food on to the spit "S", block it with the two forks "F". then proceed as follows:

The common oven installation method is as shown below, but this product is suitable for Fig.13; And Fig.14 is just for extra reference.

- ❖ Fit the end of the spit into the motor "M" at the back of the oven (Fig. 13).
- ❖ Fit the support into the circular groove in the spit.
- ❖ Unscrew and remove handle "A".
- ❖ Number "2" hooks the oven, "1" in the circle, as shown in the middle picture.
- ❖ Place the oven tray with a little water on the lowest shelf of the oven.
- ❖ Turn the knob to position to rotisserie icon .
- ❖ Partially close the oven door.

When the cooking time is up, screw the handle on the spit and remove everything from the oven. If necessary, use an oven glove to avoid any burn.

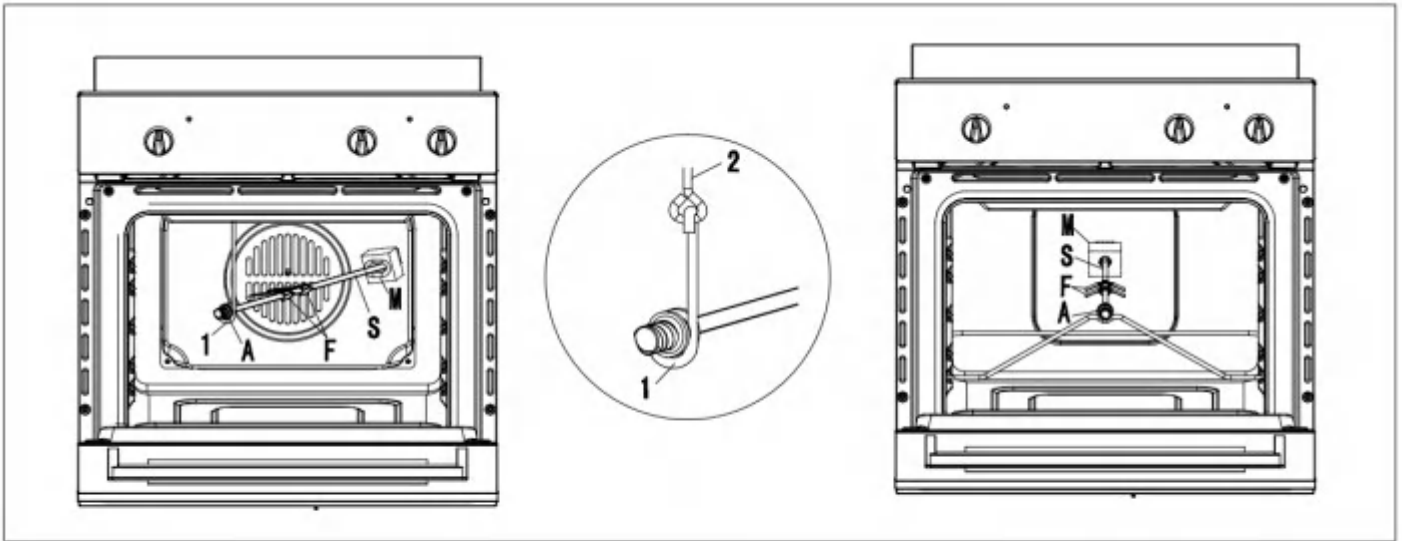

Fig.13

Fig.14

Timer & Temperature

Turn the knob clockwise to set the desired cooking time.

The adjustable range of time is 0-120 minutes.

It is recommended to be at least >5 min; there will be a sound signal and stop running when the time you set is reached.

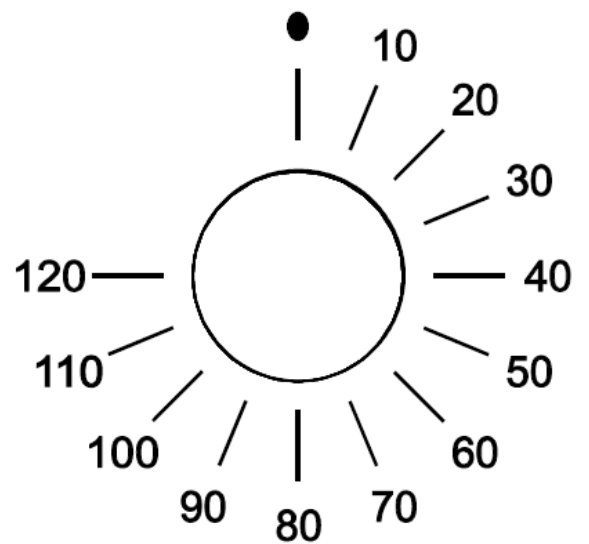

The temperature range is 0-450° F or more.

Note that the temperature difference around $\pm 59^{\circ}\text{F}$ (15°C).

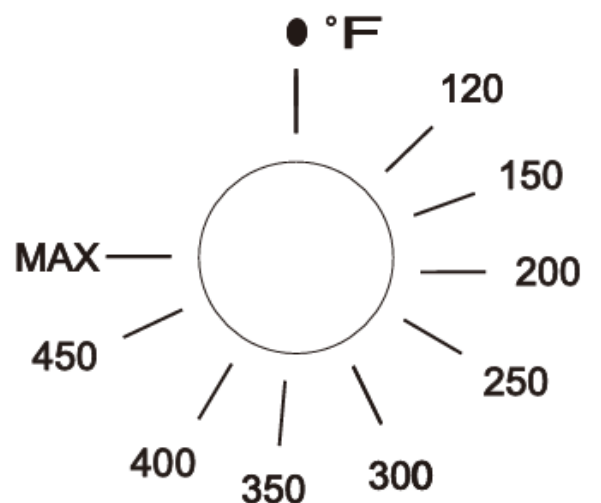

Replace the Light in Oven (Fig.15)

- ❖ Unplug your oven;
- ❖ Unscrew the glass cover attached to the lamp holder;
- ❖ Unscrew the lamp and replace it with high-temperature one, around 572°F (300°C).
- ❖ Remount the glass cover and reconnect the appliance to the power supply.



WARNING: Ensure that the appliance is unplugged before replacing the lamp to avoid the possibility of electric shock.

Warning: Do not operate the device with a damaged power cord or plug, return the unit to the nearest authorized service center for inspection and repair.

Lamp Specification:

- Voltage: AC 220V-240V
- Wattage: 25W
- Socket: G9

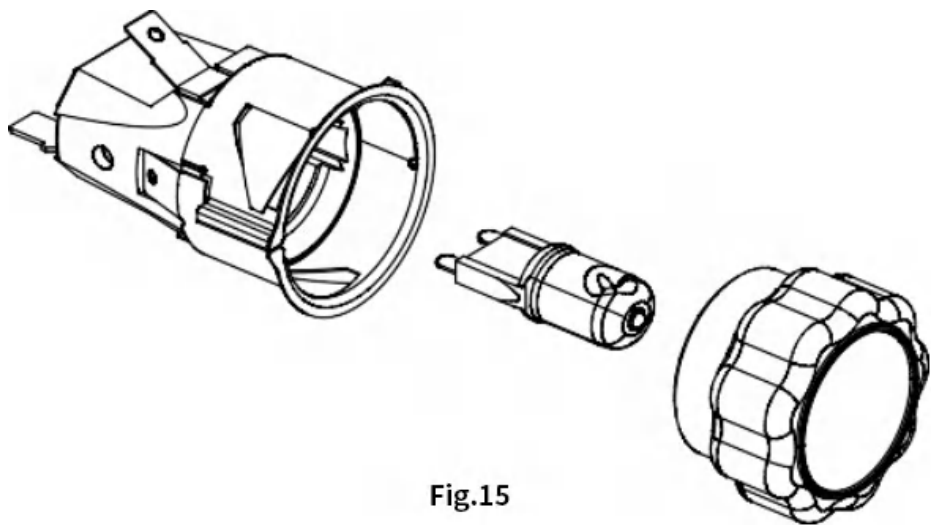

Fig.15

Cleaning & Maintenance



IMPORTANT: This appliance is only for household use, don't use it outdoors!

Important: Unplug your oven before cleaning or maintenance.

To extend the life of your oven, it must be cleaned regularly as follows:

- Do not use steam equipment to clean the appliance.
- To protect against the risk of electrical shock, do not immerse the unit, cord or plug in liquid or sprinkle water to clean the appliance.
- Don't clean the appliance when it is still hot. The inside and external surface of the oven should preferably be cleaned with damp cloth when it is cooled down.
- If you use your oven for an extended period of time, condensation may form. Dry it by using a soft cloth.
- There are rubber seals around the oven opening to ensure it works perfectly. The condition of this seal needs to be checked regularly. Avoid using abrasive products for cleaning. If damaged, please contact the nearest after-sales service center. We recommend you avoid using the oven until it has been repaired.
- Never put aluminum foil on the bottom of the oven, as heat buildup can interfere with cooking and even damage the enamel.
- Clear the glass door with a damp cloth and dry it with a soft cloth.
- Do not use harsh abrasive cleaners or sharp metal scrapers to clean the glass door since

they may scratch the surface and shatter them.



This product must not be disposed of with household waste. Disposal of electrical and electronic equipment must be carried out in a place authorized for recycling.

Collecting and recycling waste saves natural resources and ensures that products are disposed of in an environmentally friendly and healthy way.

IMPORTANT



If you decide to no longer use the oven, you should unplug and disconnect the power cord so that it cannot be used. Abandoned appliances can be a safety risk because children often play with them.

Troubleshooting

Before calling service team for support, please check the following troubleshooting tips:

Cause	Reason	Solution
The upper crust is dark but the lower part too pale	Not enough heat from the bottom.	<ul style="list-style-type: none"> ✓ Use the natural convection position; ✓ Use deeper cake tins; ✓ Lower the temp; ✓ Put the cake on a lower rack.
The lower part is dark but the upper crust too pale	Excessive heat from the bottom..	<ul style="list-style-type: none"> ✓ Use the natural convection position; ✓ Use lower side tins; ✓ Lower the temp; ✓ Put the cake on a higher rack.
Too cooked on the outside but not enough on the inside.	Temperature is too high.	Lower the temp and increase the cooking time.
The outside is too dry in the right color.	Temperature is too low.	Increase the temp and lower the cooking time.

Warranty

This warranty applies to products sold by Vikio home in the U.S. It expressly applies to a single product only.

Vikio home products come with a one-year warranty from the date of purchase against defects in material and workmanship. Please keep your receipt, as proof of purchase will be necessary to make a warranty claim. Within this warranty period, we may offer repairs, refunds, or replacements at our discretion.

The warranty provided with the product is only valid for the original consumer purchaser who buys it from an authorized retailer. It is not transferable by resale, including through unauthorized third-party retailers. If you purchase a new home, the warranty period will begin on the date you take ownership.

This warranty does not cover and excludes damage or defects caused by:

- Consumer misuse
- Abuse
- Neglect includes not cleaning and regular maintenance as described in manual
- Commercial use
- Subject the product to any voltage outside the specified range
- Loss of parts
- The affixing of any attachments not provided with the product
- Accident
- Use in a manner not intended and outlined in the manual.

Any subsequent damages caused by the above listed exclusions will not be covered and any claims determined to meet the above exclusions will be denied. All liability is limited to the purchase price and does not include any:

- Retail offered extended warranties
- Tax
- Other charges (including postage to send required materials)
- Incidental and/or consequential damages associated with the product in question.

Every implied warranty, including any statutory warranty of merchantability or fitness for a particular purpose is disclaimed except to the extent prohibited by law, in which case such warranty is limited to the duration of this written warranty. This warranty gives you specific legal rights. You may have other legal rights that vary depending on where you live. Some states do not allow limitations on implied warranties or special, incidental, or consequential damages, so the above limitations may not apply to you.

If you have a claim under this warranty, please contact : **service02@vikihome.com**
For faster service, please provide the model number, serial number, and receipt ready for the operator to assist you.