





Read this instruction carefully. See hardware and furniture part list for guidance.
 Be sure all parts are complete before assembly. Place all wooden furniture parts on a clean and flat soft surface to prevent from being scratched.
 Follow the figure to start assembling.

CAUTION : 1. Do not FULLY - TIGHTEN the nuts or nuts bolts until they are ready for assembly.
 2. Do not OVER - TIGHTEN the nuts or bolts to avoid causing damages to the thread.
 3. Keep all hardware parts out of reach of children.

NOTE : THE LIST AND QUANTITY SHOWN ARE FOR 1 UNIT ASSEMBLY.

Tools needed : Screwdriver (not provided).

PART LIST			
ITEM	DESCRIPTION	BOX	QTY
A	BACK	1	1 PC
B	CENTER WOOD	1	2 PCS
C	LEG FRONT	1	1 PC
D	CUHSION	1	1 PC

HARDWARE LIST (BOX : 1)			
ITEM	DESCRIPTION		QTY
1	JCBC BOLT M6 x 50mm		8 PCS
2	M6 SPRING WASHER		8 PCS
3	WOOD SCREW M4 x 35mm		6 PCS
4	WOOD DOWEL M8 x 30mm		4 PCS
5	M4 ALLEN KEY (BALL SHAPE)		1 PC

STEP 1

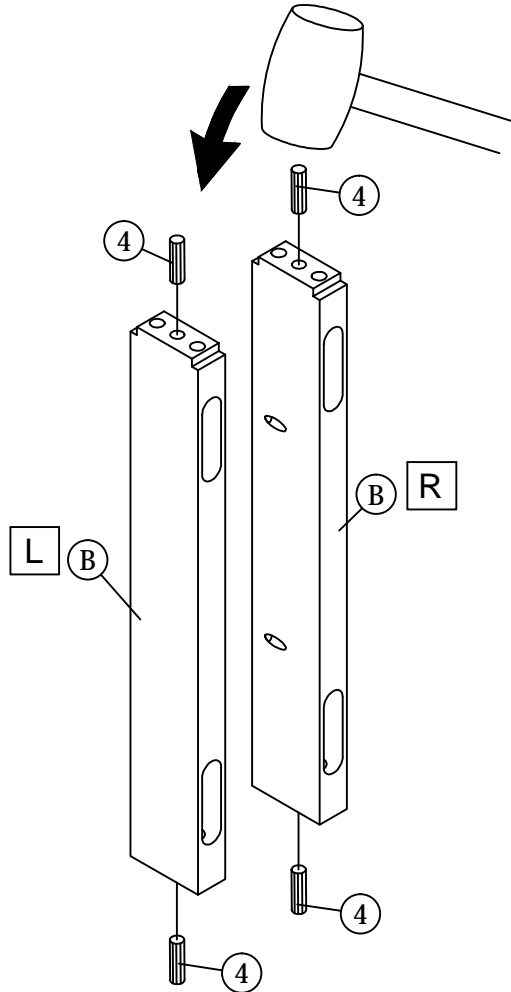

STEP 2

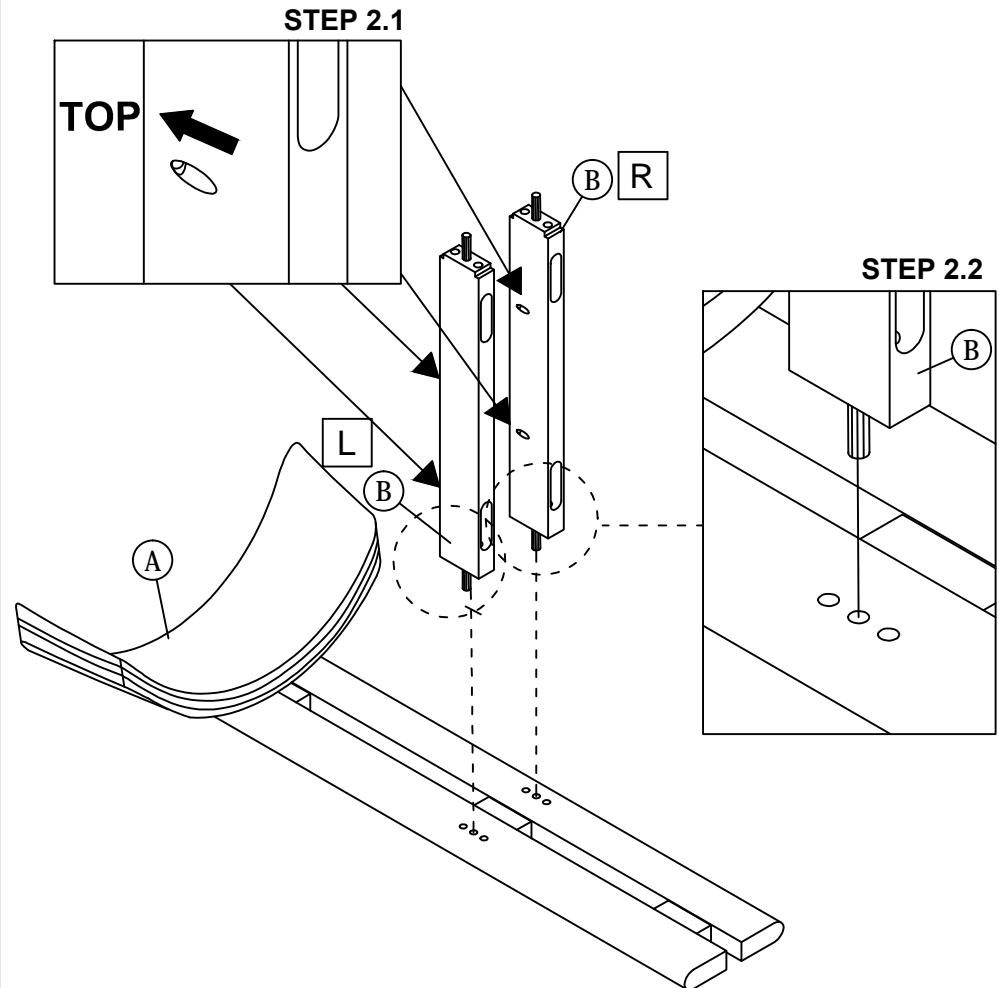

ASSEMBLY INSTRUCTIONS

STEP 3

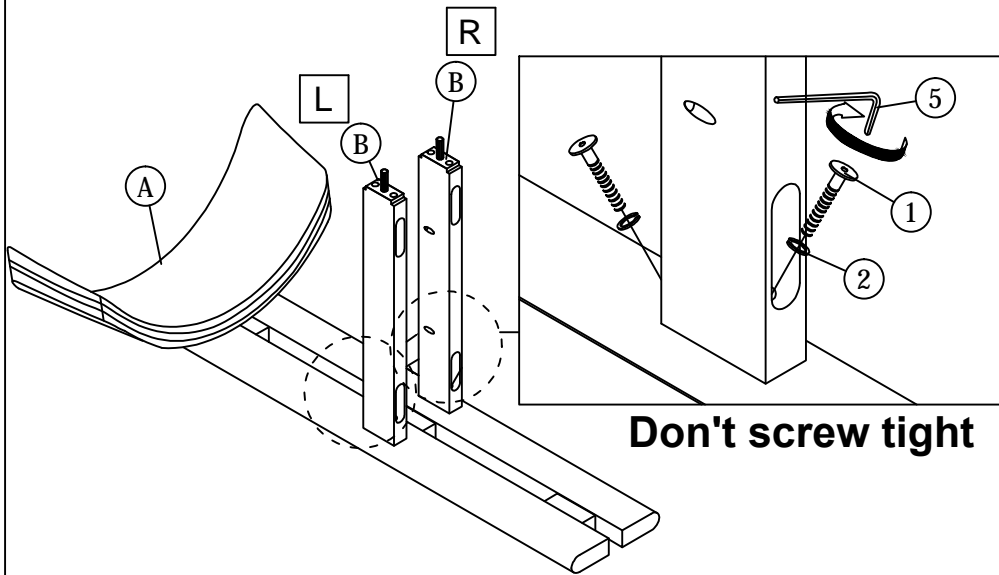

STEP 4

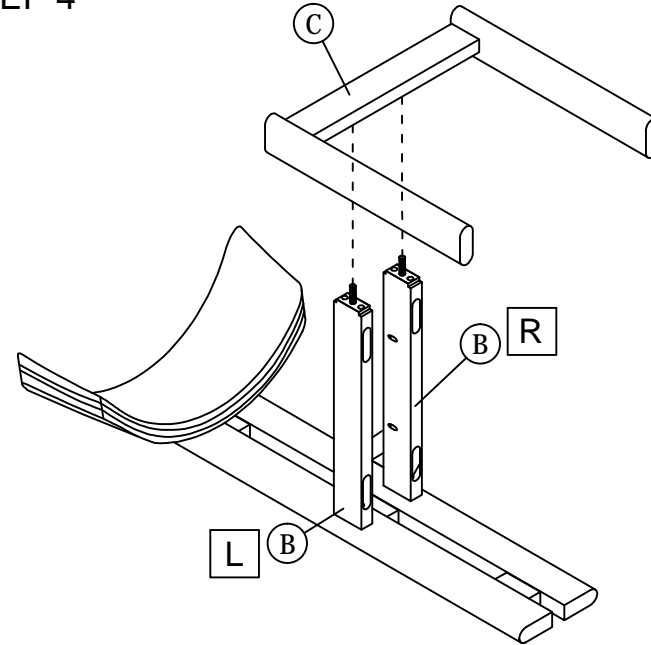

STEP 5

Don't screw tight

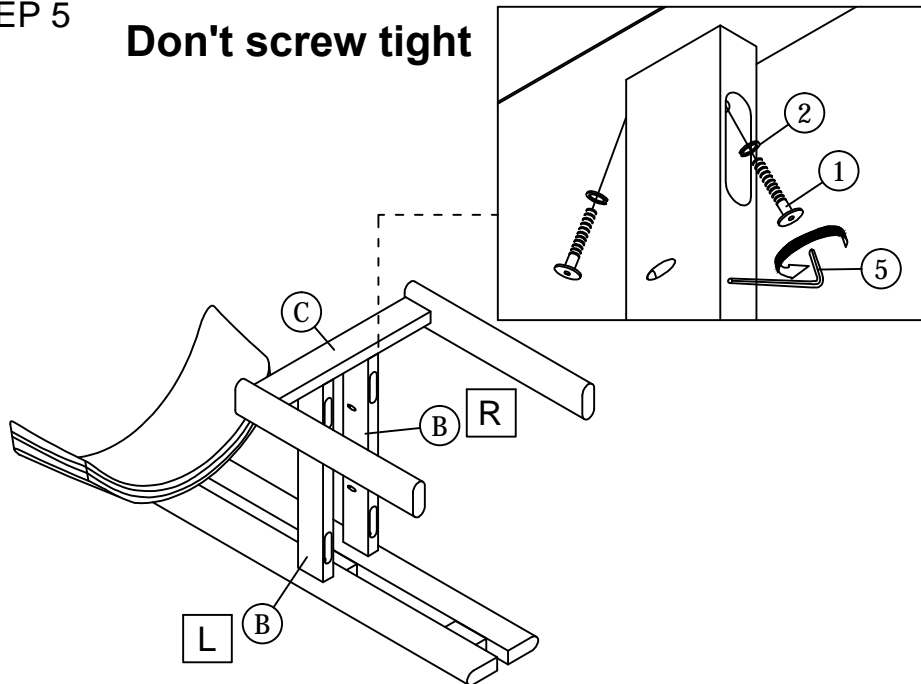

STEP 6

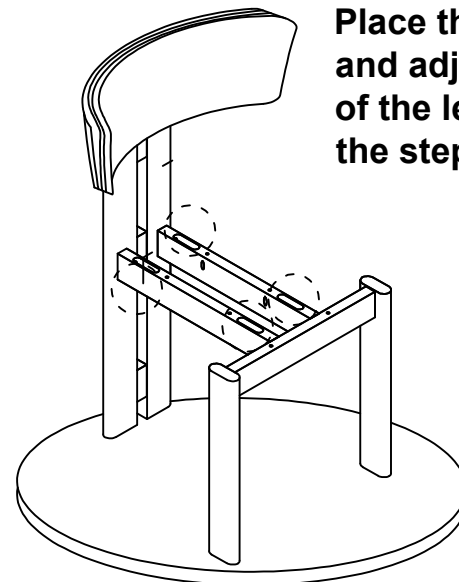

Place the chair on the flat surface and adjust the alignment and balance of the legs then , Please screw tight the steps 3 , 5 bolts.

ASSEMBLY INSTRUCTIONS

STEP 7

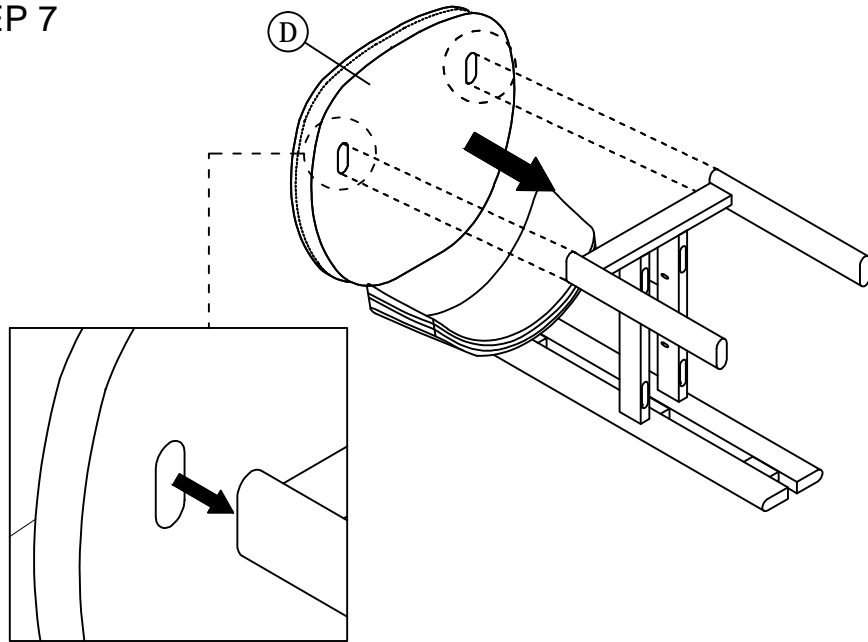

STEP 8

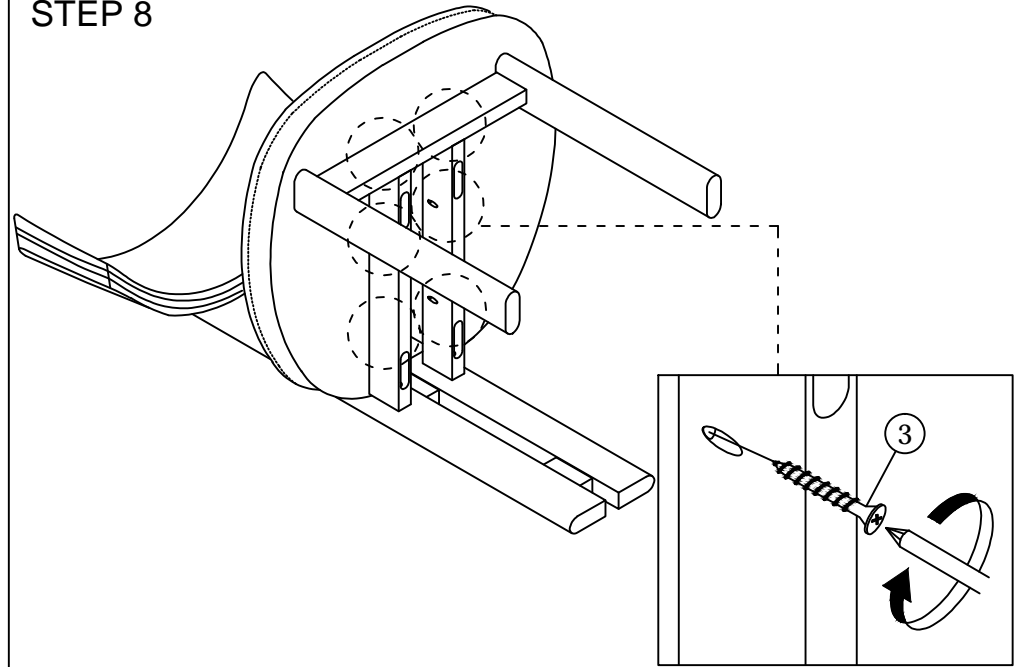

STEP 9

