

# ASSEMBLY INSTRUCTION

---

## RATTAN SOFA SET

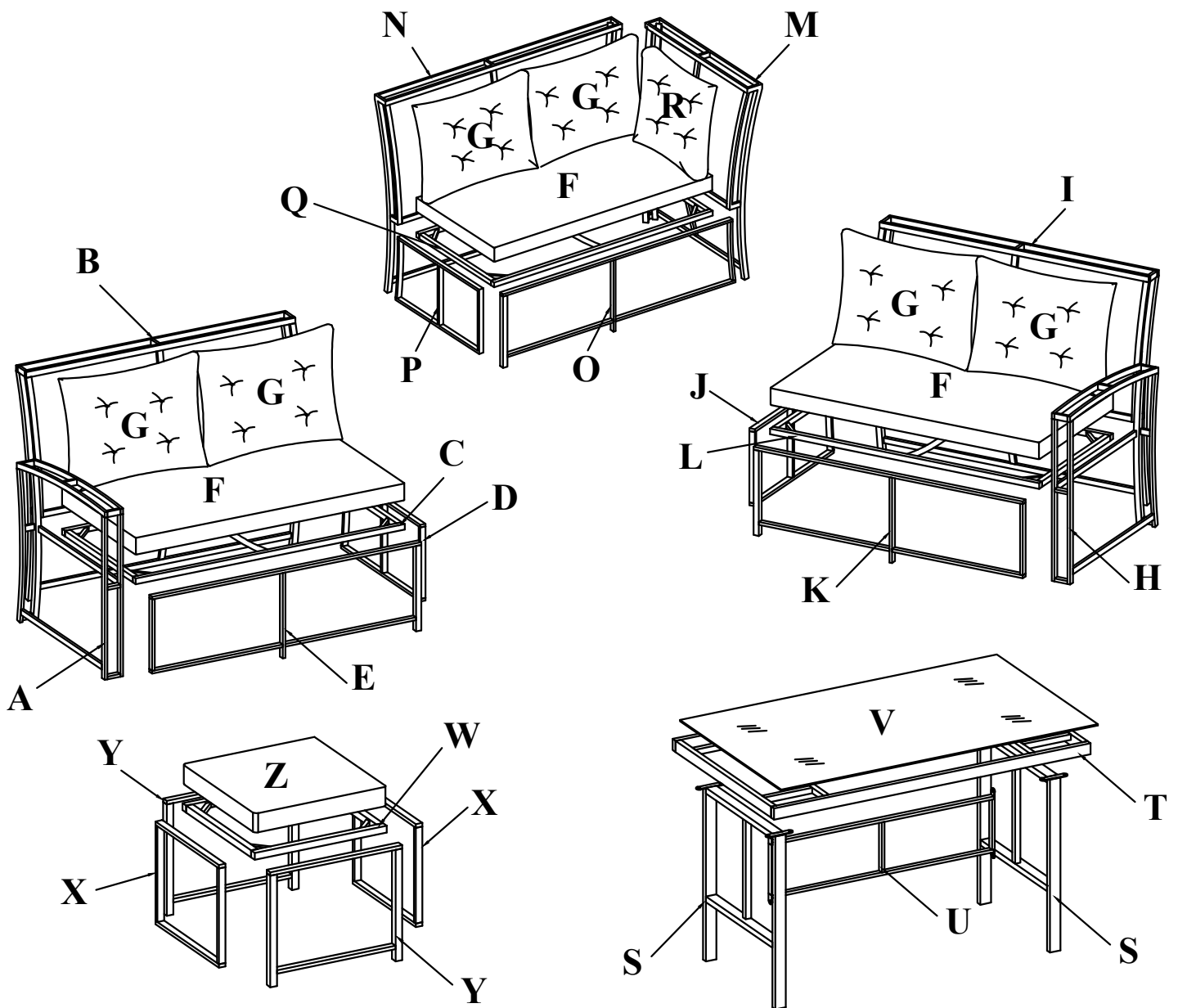



**Notice:**

1. **50% Tighten before fixing all screws, Allen wrench is recommended instead of an electric drill.**
2. **Place the item on a flat ground to adjust and make sure it remains stable.**
3. **Tighten up all screws with tools gradually.**
4. **If the screws are not aligned with holes during assembly, please loosen all the other screws to 50% and continue the assembly process.**
5. **If the item is not stable, please loosen all the screws, adjust it on a flat ground and tighten up all screws again.**
6. **Note: If one or some screws are fully tightened during assembly, chances are the others will not be aligned with holes. In addition, all the holes are designed to be relatively larger to provide more space for the adjustment of the screws.**

**Part list**

**A**

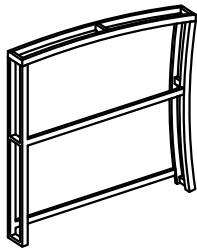

**Bench right frame (1 pc)**

**B**

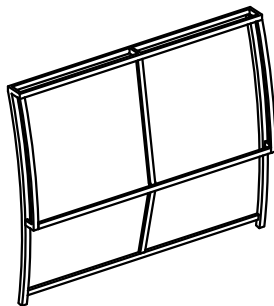

**Bench right back frame (1 pc)**

**C**

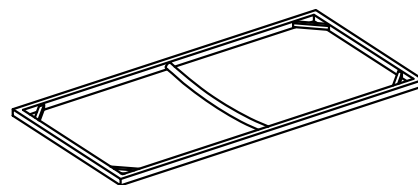

**Bench right seat frame (1 pc)**

**D**

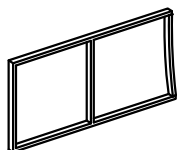

**Bench right side frame (1 pc)**

**E**

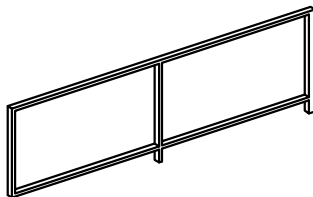

**Bench right front frame (1 pc)**

**F**

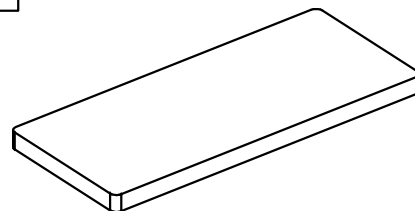

**Bench/Corner seat cushion (3 pcs)**

**G**

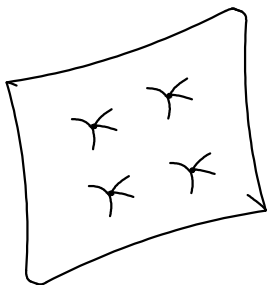

**Pillow long (6 pcs)**

**H**

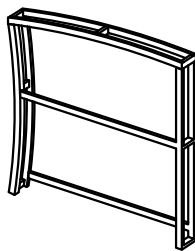

**Bench left frame (1 pc)**

**I**

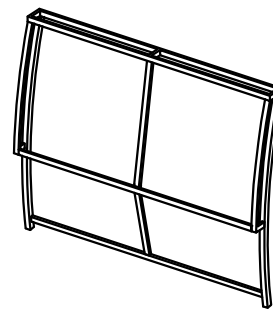

**Bench left back frame (1 pc)**

**J**

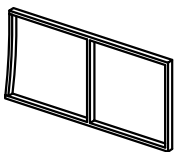

**Bench left side frame (1 pc)**

**K**

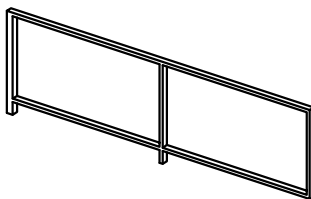

**Bench left front frame (1 pc)**

**L**

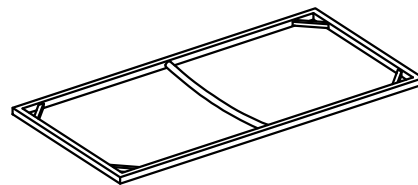

**Bench left seat frame (1 pc)**

**M**

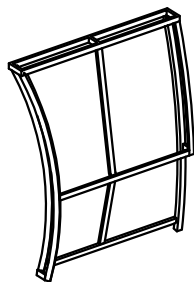

**Corner short back frame (1 pc)**

**N**

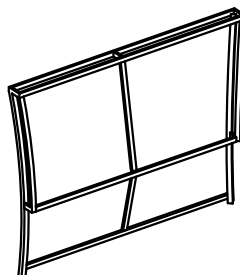

**Corner long back frame (1 pc)**

**O**

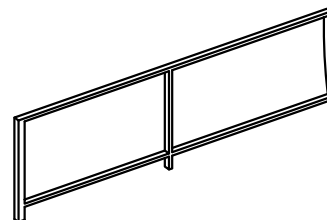

**Corner front frame (1 pc)**

**Part list**

**P**

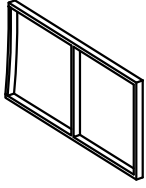

**Corner  
side frame (1 pc)**

**Q**

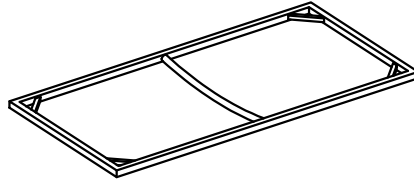

**Corner  
seat frame (1 pc)**

**R**

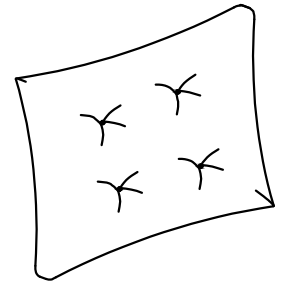

**Pillow short (1 pc)**

**S**

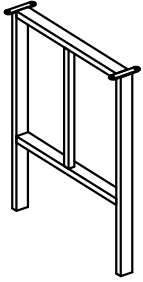

**Table leg (2 pcs)**

**T**

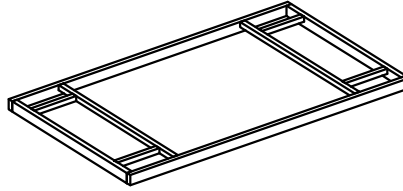

**Table top frame (1 pc)**

**U**

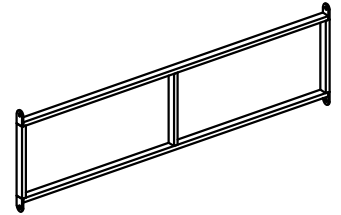

**Bracing table (1 pc)**

**V**

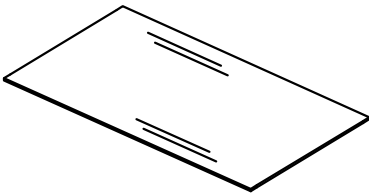

**Table glass (1 pc)**

**W**

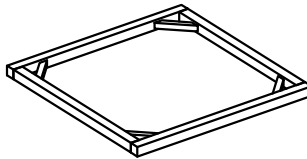

**Stool seat frame (2 pcs)**

**X**

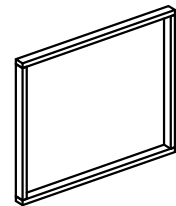

**Stool side frame (4 pcs)**

**Y**

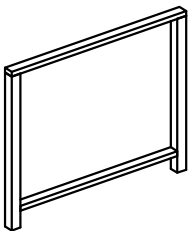

**Stool front frame (4 pcs)**

**Z**

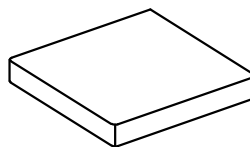

**Stool seat cushion (2 pcs)**

**1**

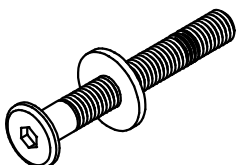

**Bolt M6 x 100 mm  
(2 pcs) + extra 1pc**

**2**

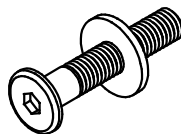

**Bolt M6 x 40 mm  
(9 pcs) + extra 1pc**

**3**

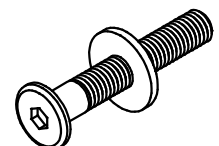

**Bolt M6x30 mm  
(45 pcs)+ extra 3pcs**

# Part list

4



**Bolt M6x20 mm  
(24 pcs)+ extra 2pcs**

5

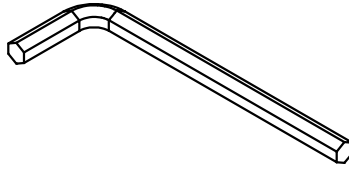

**Allen key M4 (2 pcs)**

6

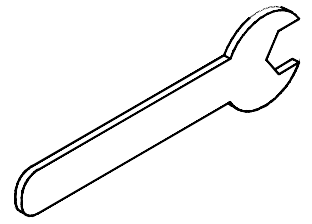

**Spanner (1 pc)**

7

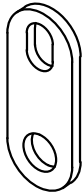

**Connector (6 pcs)**

**WF319208**

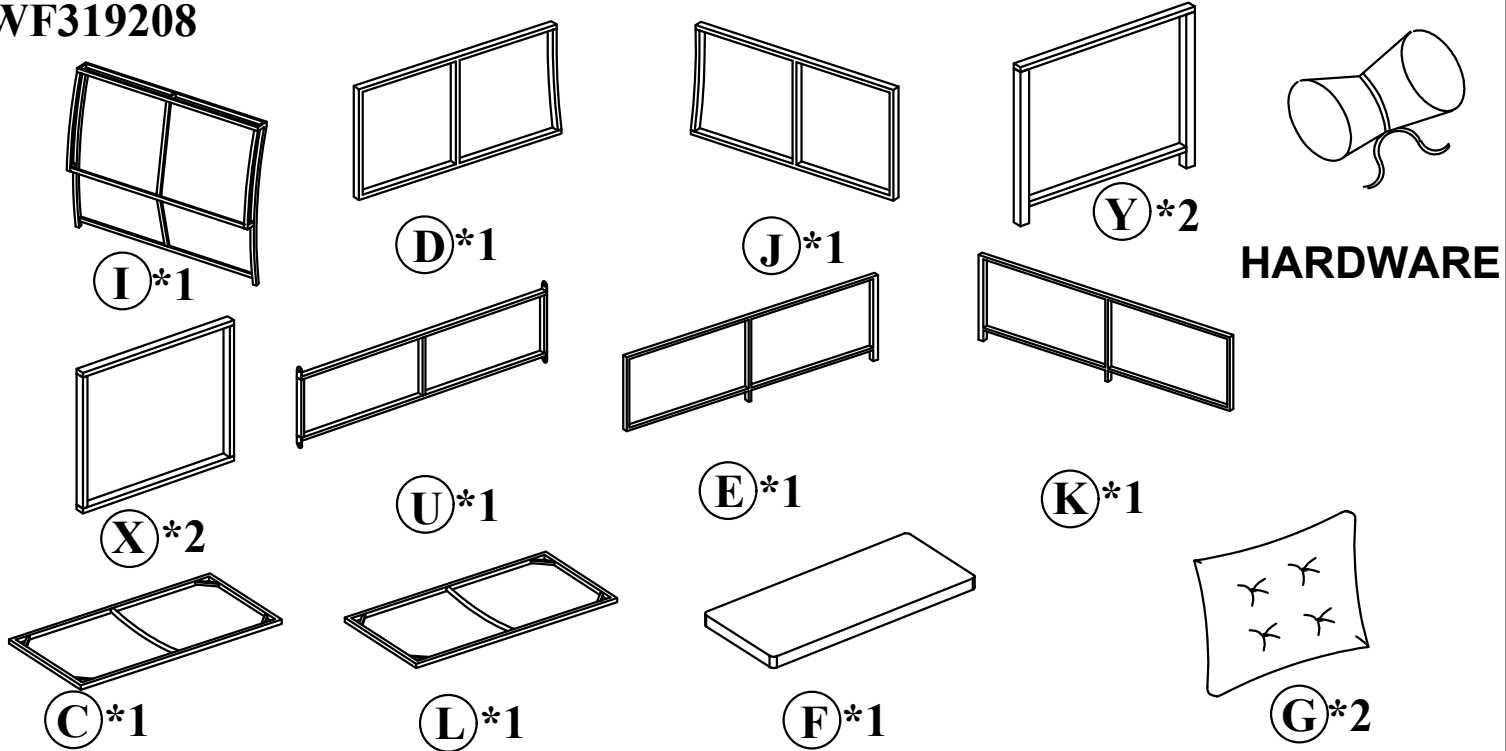

**WF319209**

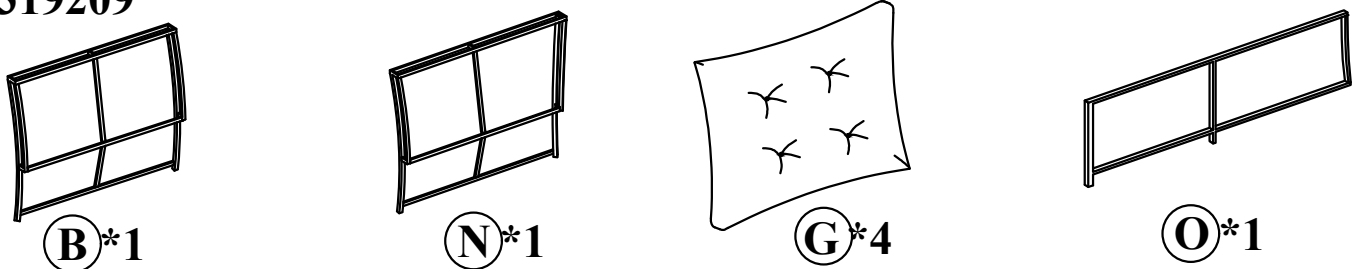

**WF319210**

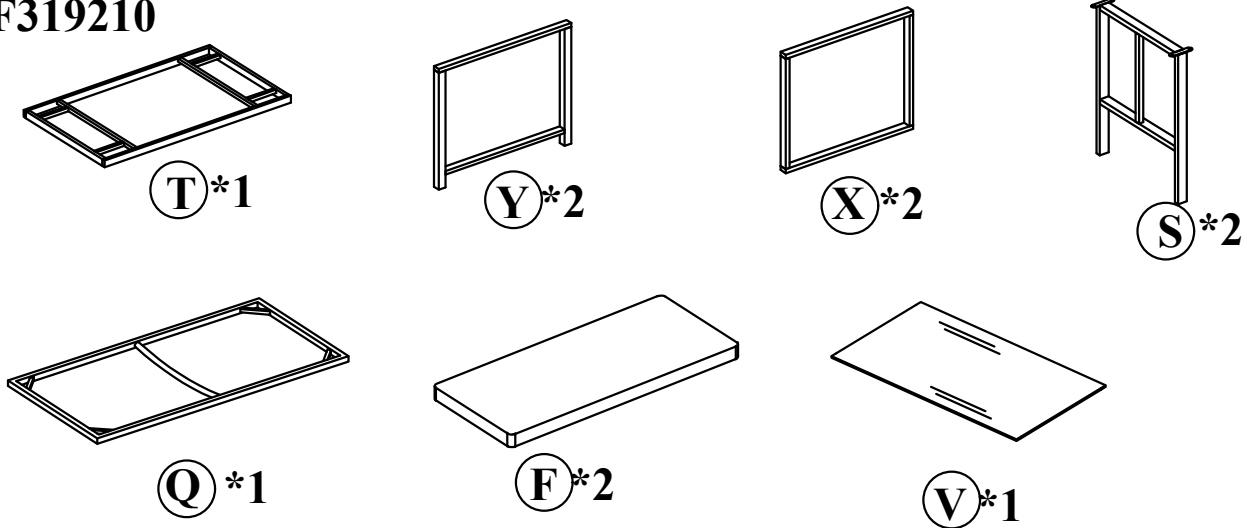

**WF319211**

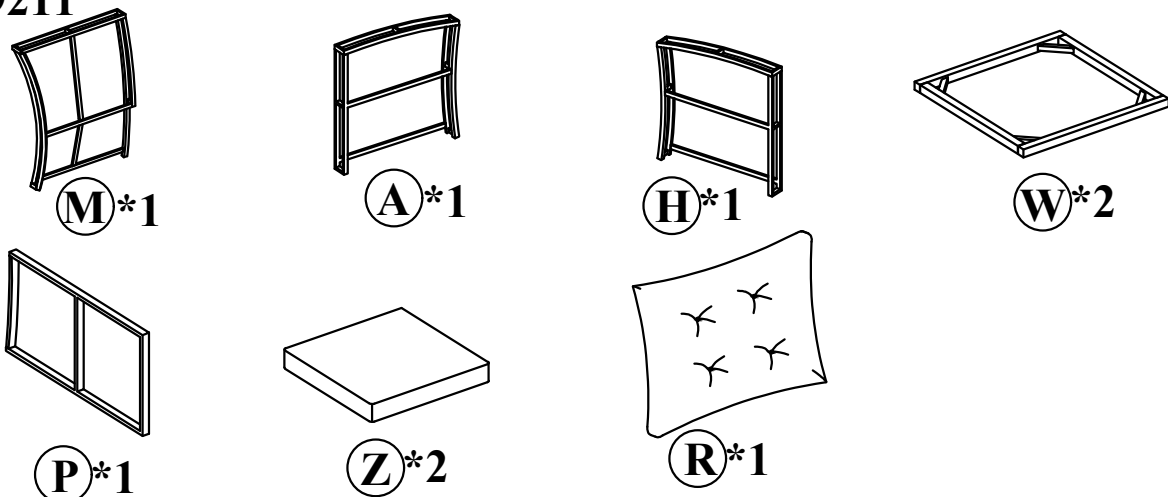

**(Bench right assembly)**  
**STEP 1**

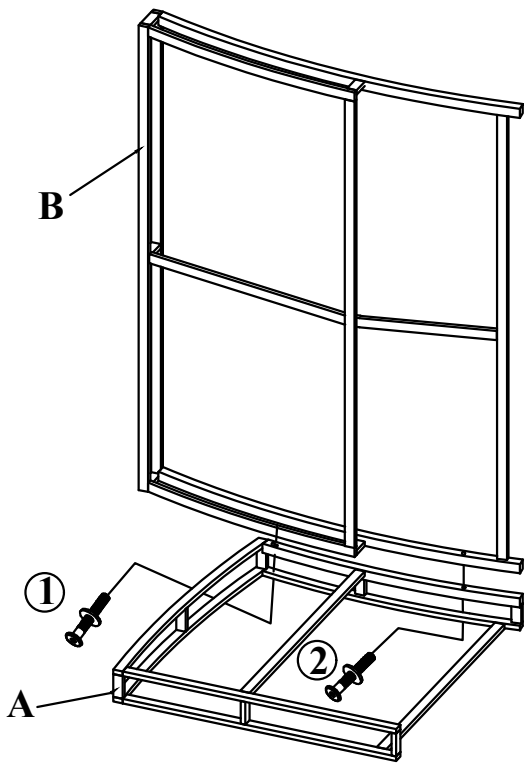
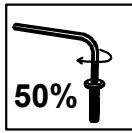

①\*1 ②\*1

**STEP 2**

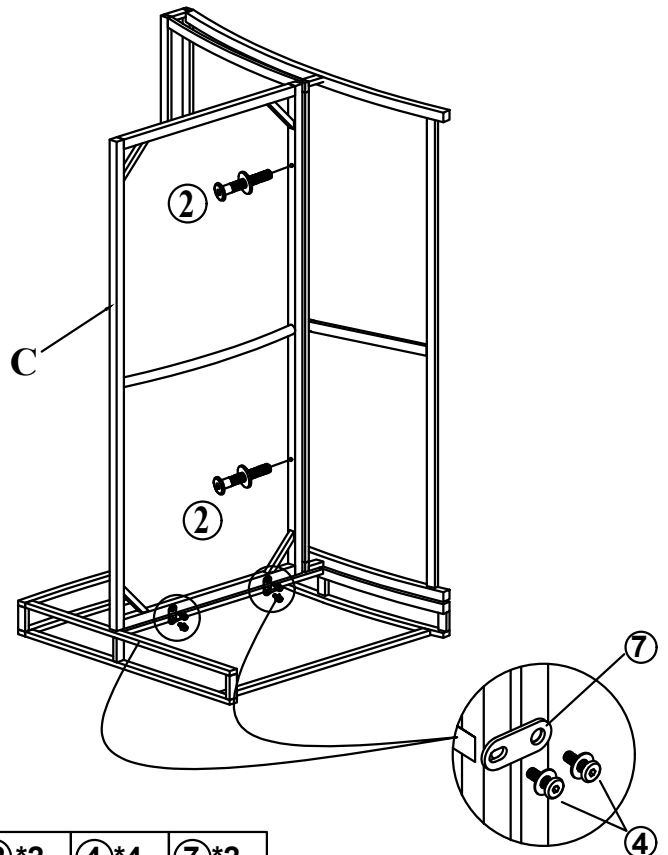

②\*2 ④\*4 ⑦\*2

**STEP 3**

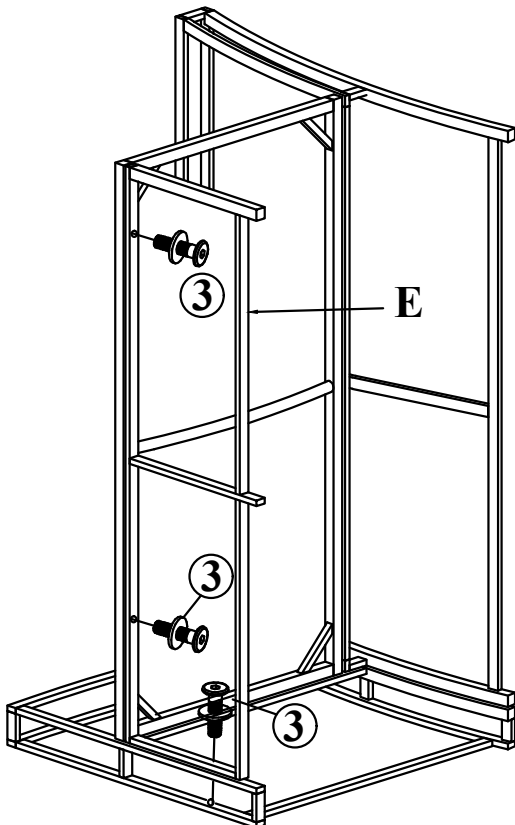
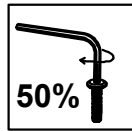

③\*3

**STEP 4**

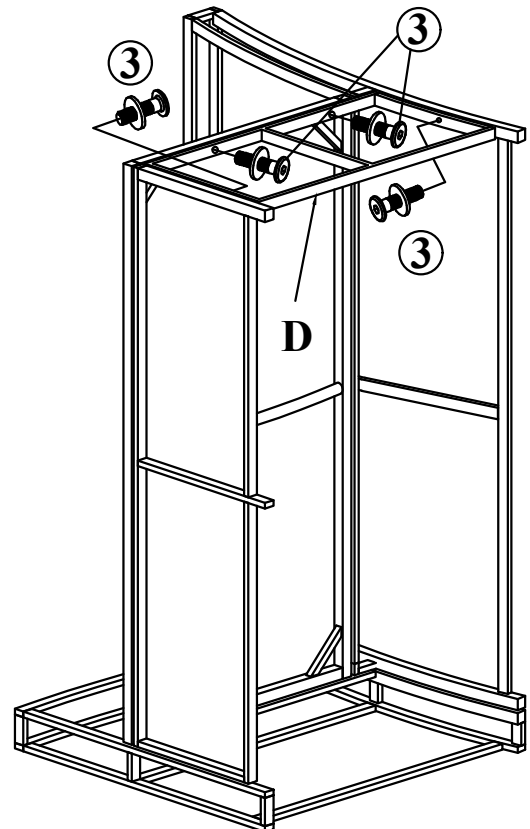
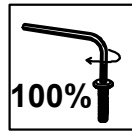

③\*4

**(Bench left assembly)**

**STEP 5**

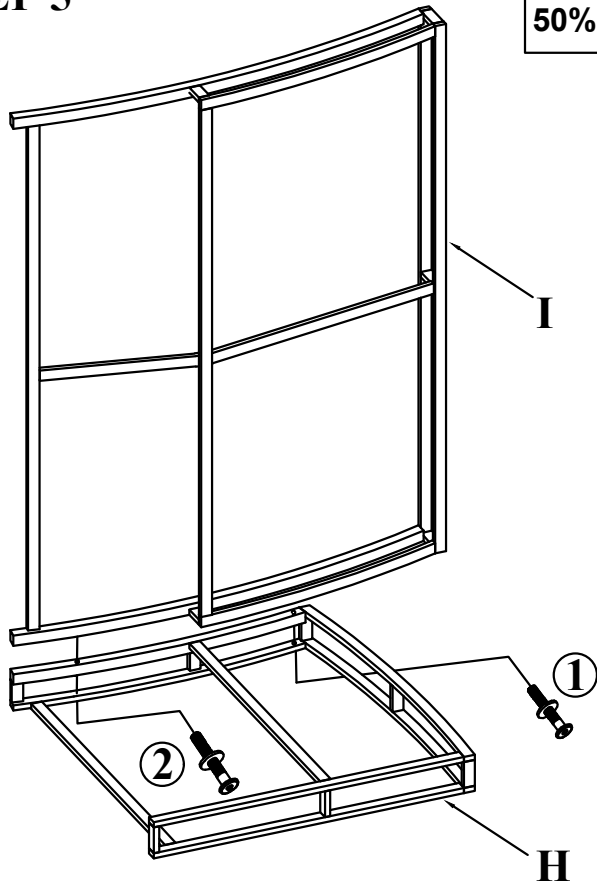

①\*1 ②\*1

**STEP 6**

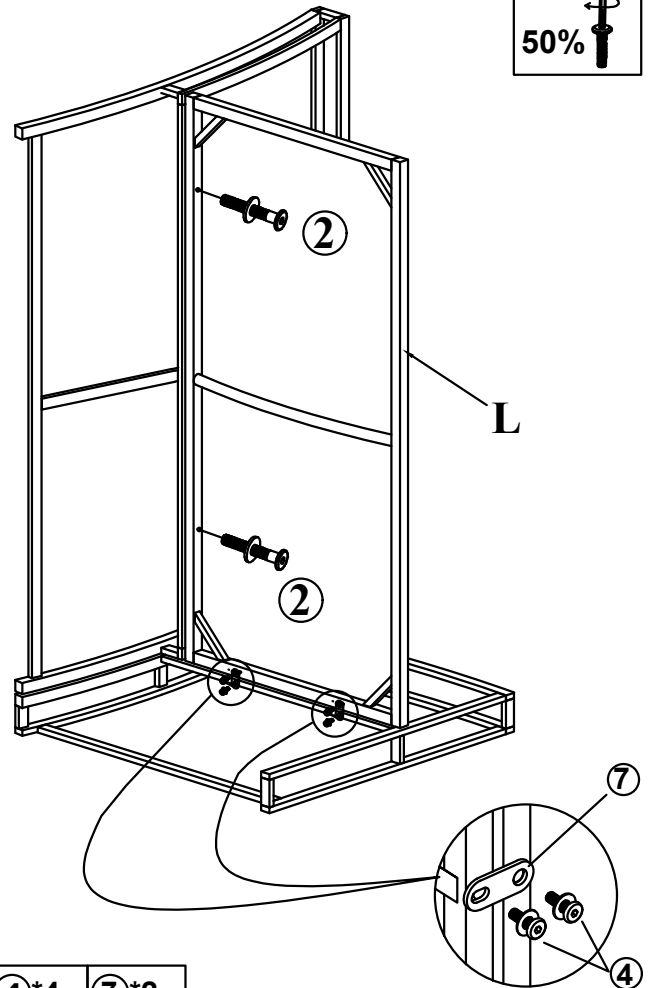

②\*2 ④\*4 ⑦\*2

**STEP 7**

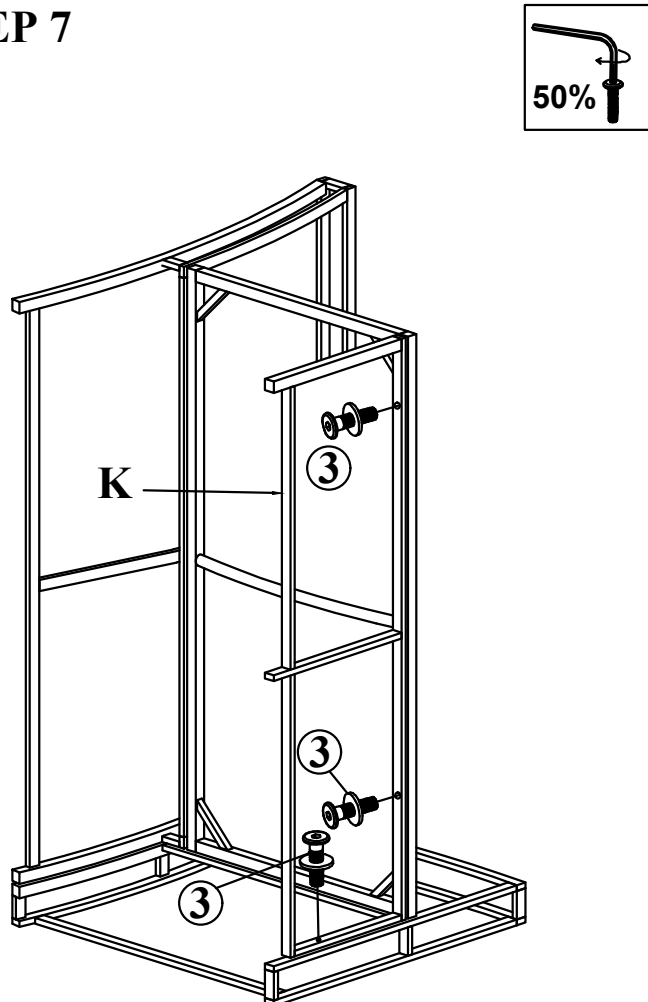

③\*3

**STEP 8**

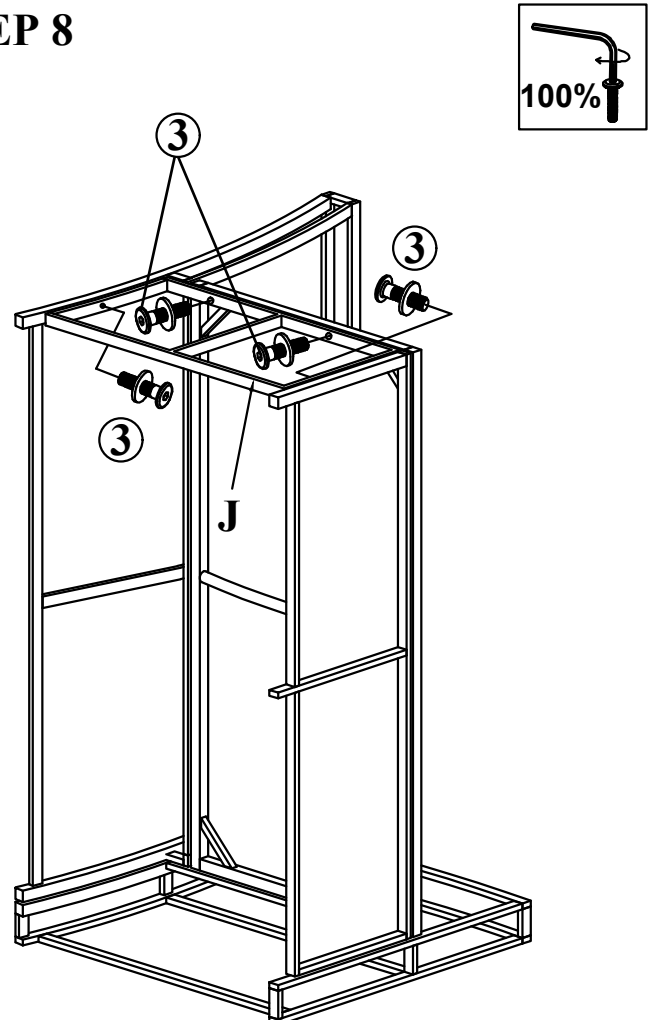

③\*4

(Corner assembly)

STEP 9

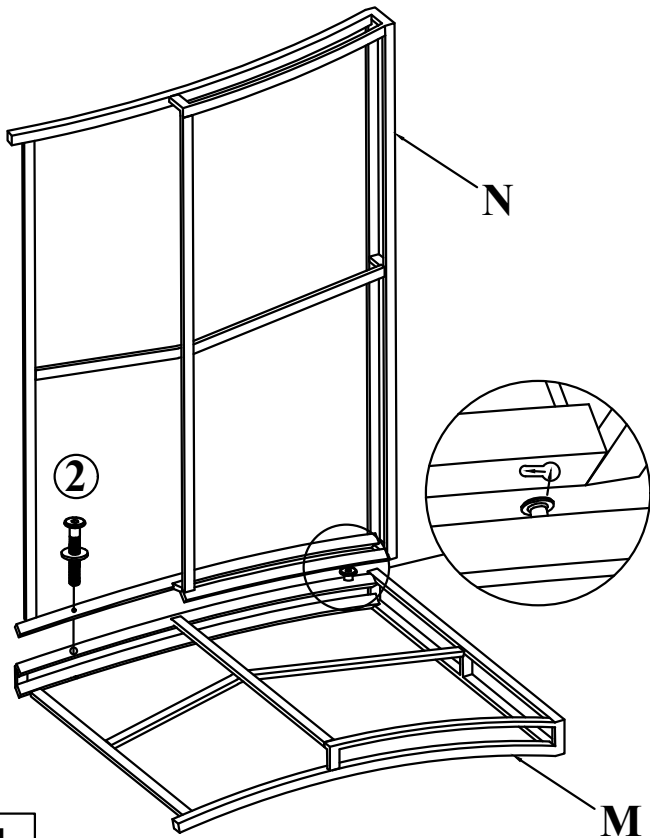
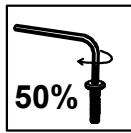

STEP 10

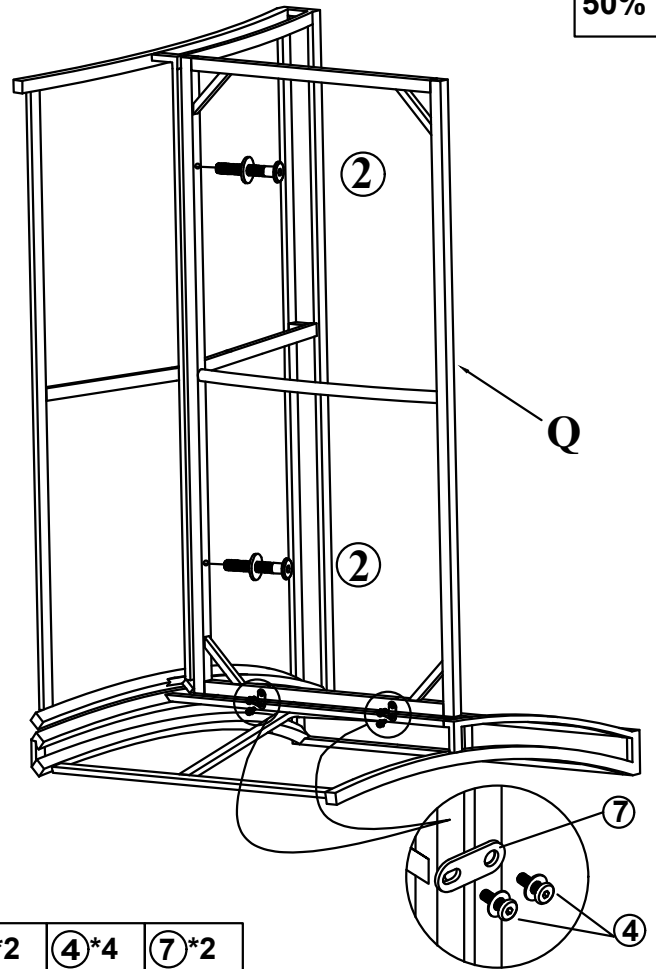
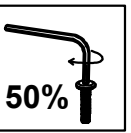

STEP 11

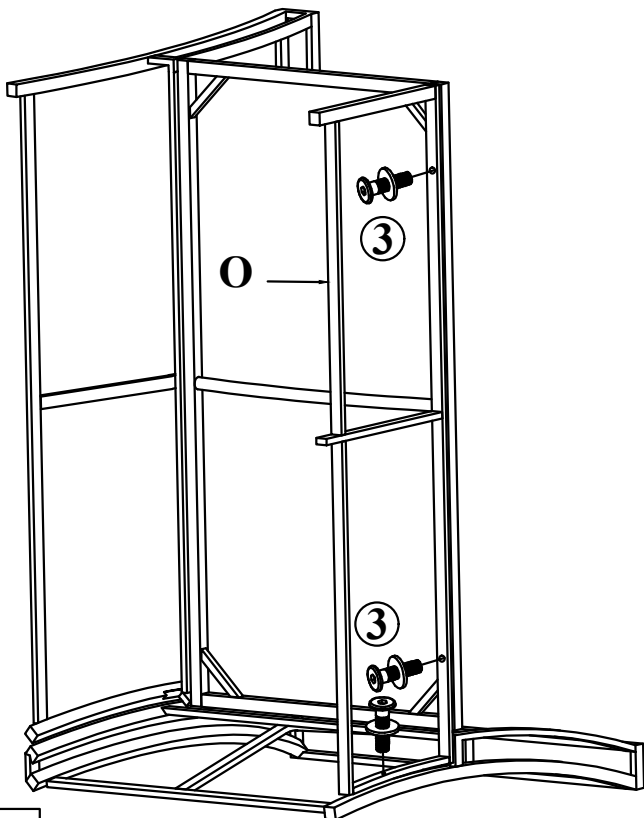
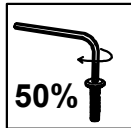

STEP 12

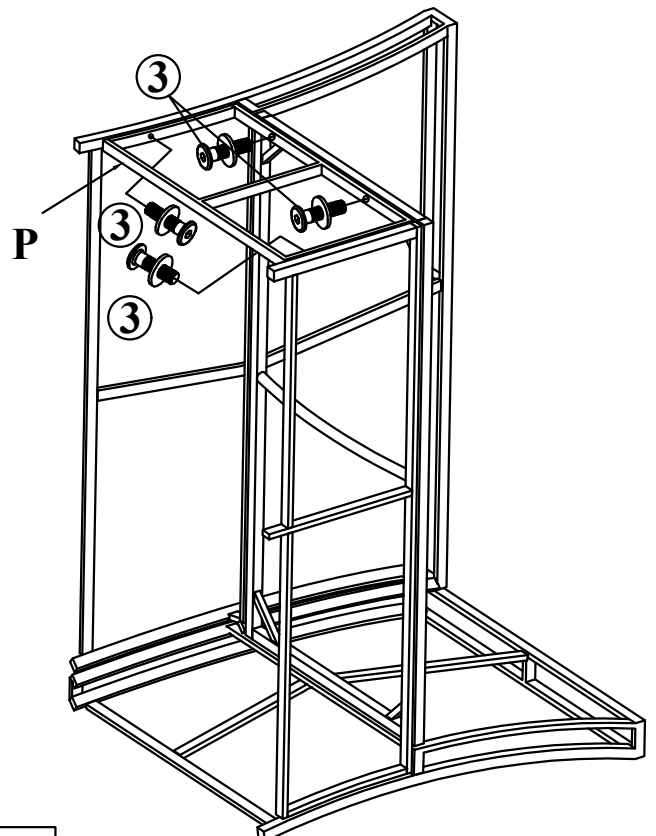
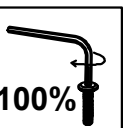

(Stool assembly)  
**STEP 13**

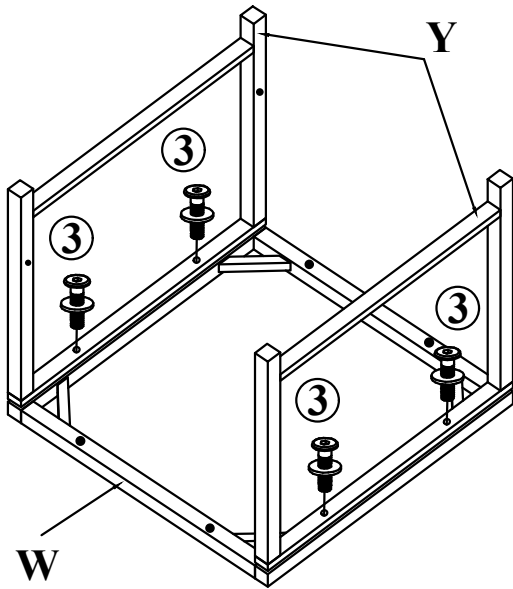
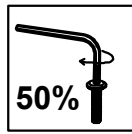

③\*4

**STEP 14**

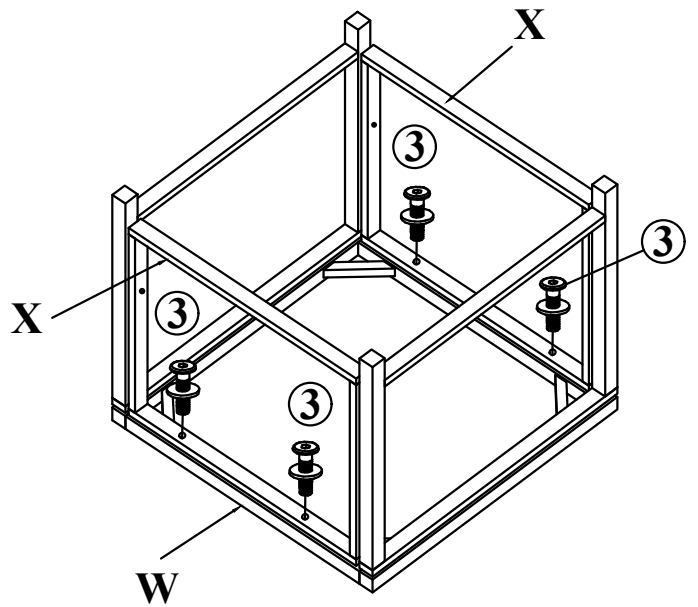

③\*4

**STEP 15**

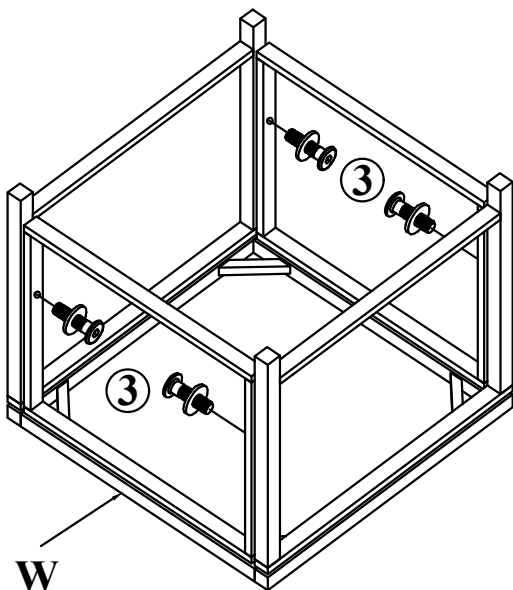
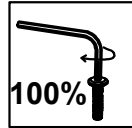

③\*4

**STEP 16**

Put on Seat Cushion (Z) to complete Stool

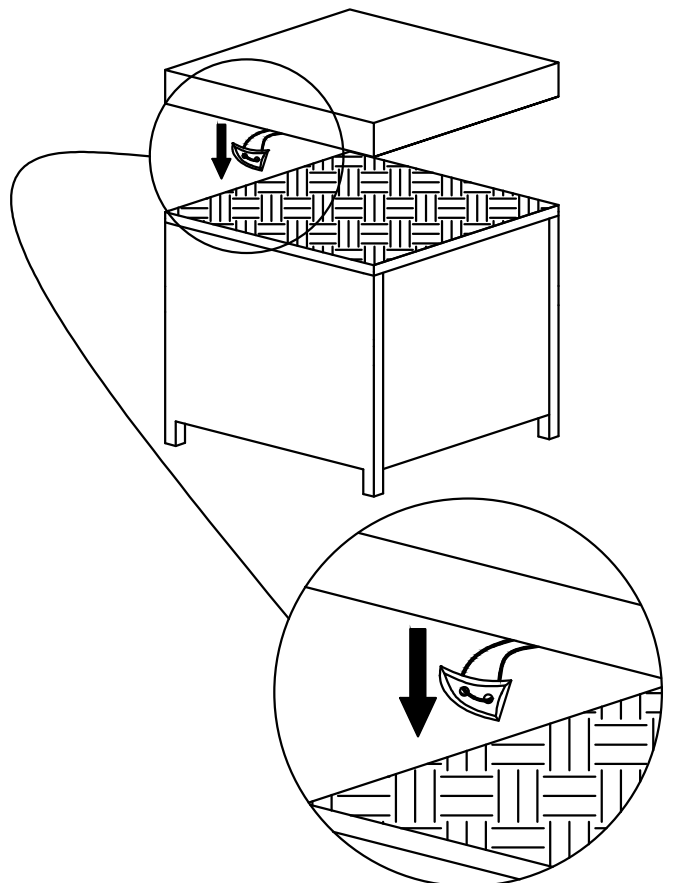

(Table assembly)

STEP 17

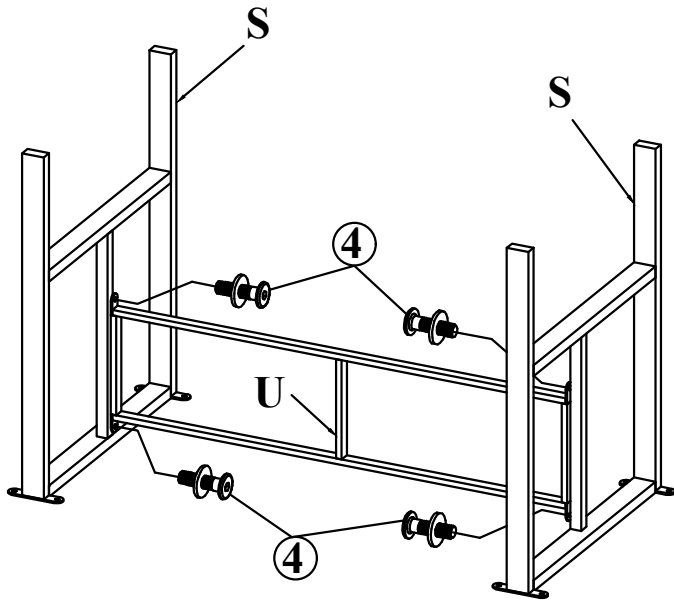
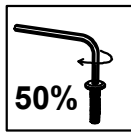

④\*4

STEP 18

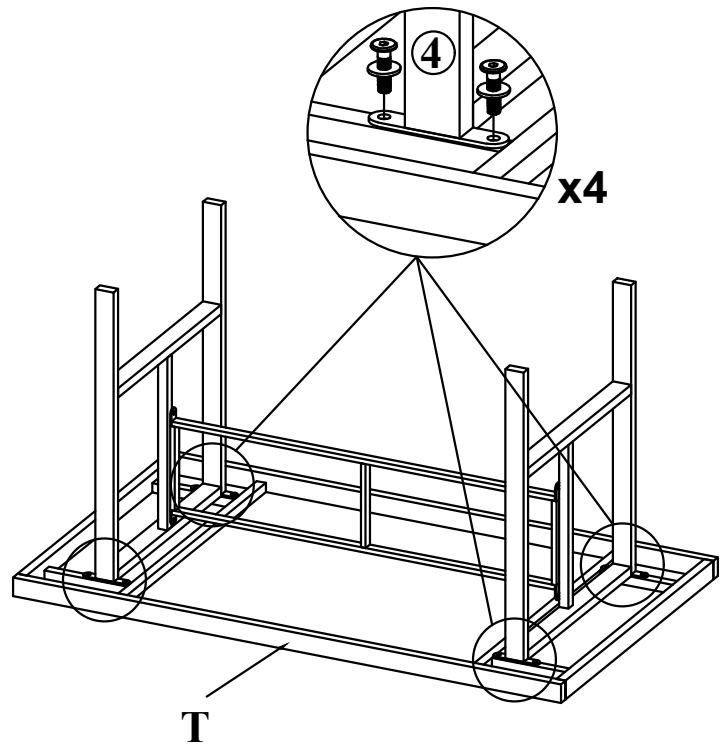

④\*8

STEP 19

Put on Bench/Corner Seat Cushion (F), Pillow (G), Pillow (R) & Glass Table (V) to complete sofa

