

# ASSEMBLY INSTRUCTIONS

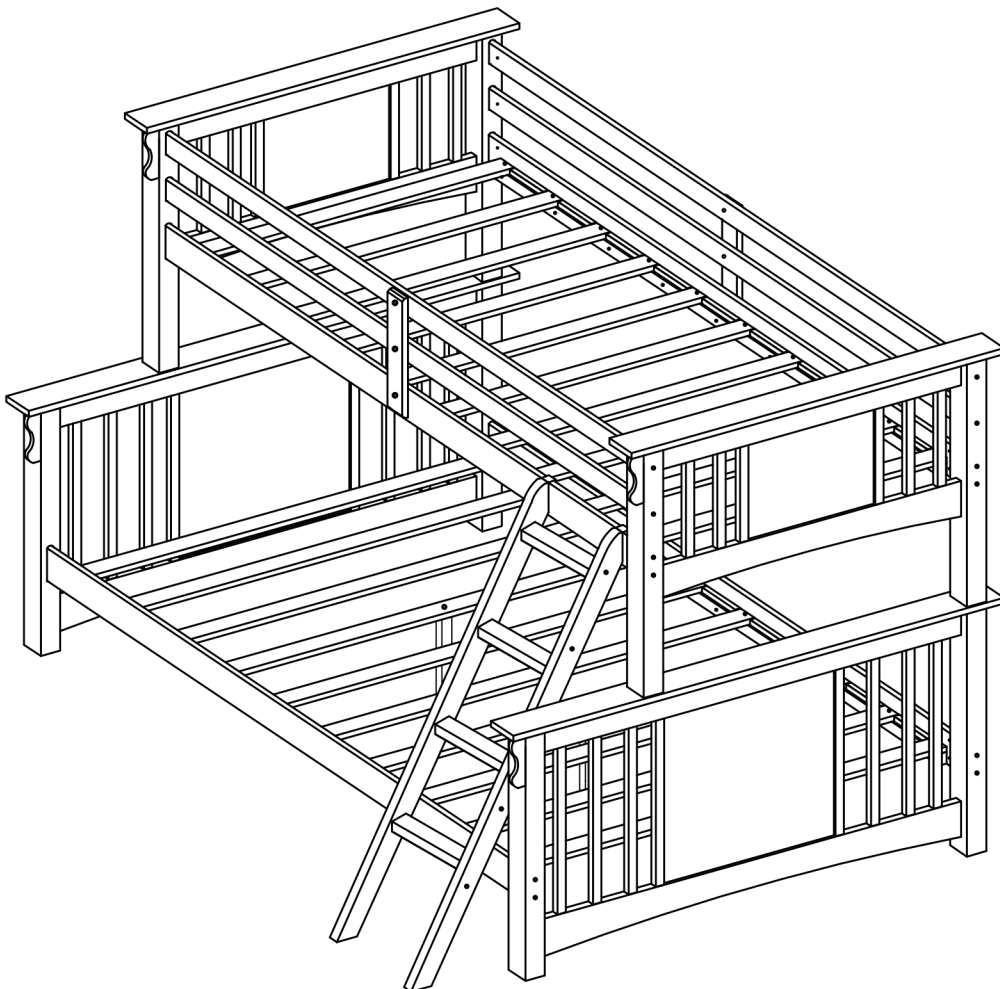

## TOOLS REQUIRED



Allen Wrench

(Included)



Phillips  
Screwdriver

(Not Included)



2 - People  
Recommended

## ASSEMBLY RATING



EASY ————— DIFFICULT

The Assembly Rating is a 5-point system showing the level of effort needed to assemble a specific product.



## CHECK BEFORE STARTING

### Are you missing anything?

Double-check all parts, hardware and accessories listed on Page 6 are accounted for.

### Should we send any replacements?

Are there any irregularities or flaws in the parts? We can send replacements!

### Check out our Quick Tips!

We recommend reviewing the pre-assembly handouts. Even experts need a refresher now and then!

### Prep Time!

Please review the assembly instructions and all diagrams prior to assembling. Arrange parts as recommended on Page 7 and group identical hardware together to make assembling easier.

# PRE ASSEMBLY INTRODUCTION

We understand building ready-to-assemble furniture can be a challenging experience for some. To help avoid confusion, we have provided some helpful tips that may speed up the process.

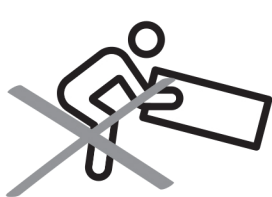

## Teamwork

ALWAYS have at least two people to help with transporting and assembling the product to avoid potential injury and/or damage.

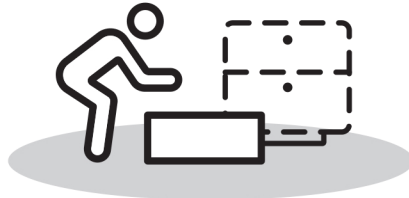

## Suitable Location

Assembling near the area of the intended location is highly recommended.



## Sufficient Space

Make sure you have enough space to move around during the assembly.



## Avoid Scratches

Use cardboard, blankets or a carpeted area while assembling furniture to prevent scratches.

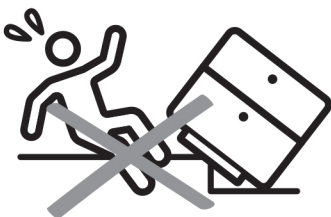

## Flat Surface

Make sure the furniture rests on a flat and level surface with each leg evenly touching the floor.

# ASSEMBLY AND CARE ADVICE



**FAILURE TO FOLLOW THE GUIDELINES BELOW MAY RESULT IN INJURY AND/OR PROPERTY DAMAGE.**



Position each part correctly and insert screws or bolts into their respective holes.



Turn clockwise to tighten and only tighten when step is completed or when instructed to do so.



Use the appropriate hand tools or power tools for assembly. Select steps, such as tightening screws and/or bolts, may require hand tools to avoid causing damage during assembly.



Save the instructions and store any supplied tools for later maintenance.



After two weeks, check and tighten any loose hardware and repeat again every six months thereafter.

**IT IS THE USER'S RESPONSIBILITY TO MAINTAIN THE FURNITURE. THE HARDWARE MAY LOOSEN OVER TIME AND MAY CAUSE THE FURNITURE TO BE WOBBLY AND UNABLE TO SUPPORT ITS INTENDED WEIGHT CAPACITY. THIS MAY LEAD TO COLLAPSE AND MAY CAUSE SERIOUS INJURY.**

# DAYBED



- Please keep instructions for future reference.
- Check the quantity and irregularity of parts and hardware before you start.

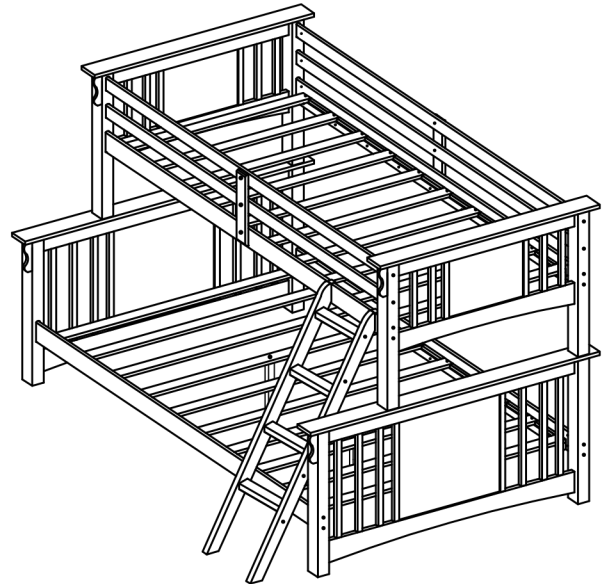

## PARTS

#1 1pc

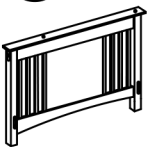

#2 1pc

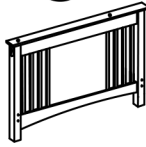

#3 2pcs

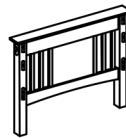

#4 2pcs

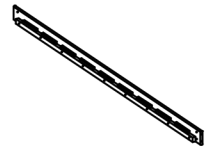

Lower Headboard (L) Lower Headboard (R) Upper Headboard/Footboard Lower Side Rail

#5 2pcs



Upper Side Rail

#6 4pcs

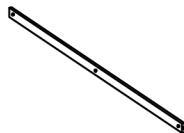

Guardrail

#7 2pcs



Full Slat Kit

#8 2pcs



Support Leg  
271x40x40mm

#9 8pcs



Full Slat Kit

#10 10pcs



Twin Slat Kit

#11 2pcs

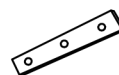

Guardrail Support

#12 4pcs



Ladder Steps

#13 1pc



Ladder Rail (L)

#14 1pc



Ladder Rail (R)

## HARDWARE

#A 24pcs



Bolt  
Ø1/4" x 4-7/8"

#B 24pcs



Barrel Nut  
Ø1/4" x 1/2"

#C 2pcs



Screw  
#4x40mm

#D 40pcs



Screw  
#4x30mm

#E 6pcs



Bolt  
Ø1/4" x 1-3/16"

#F 4pcs

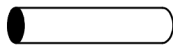

Metal Dowel  
Ø9 x 90mm

#G 8pcs

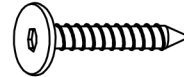

Screw  
Ø1/4" x 1/2"

#H 2pcs



Screw  
#4x20mm









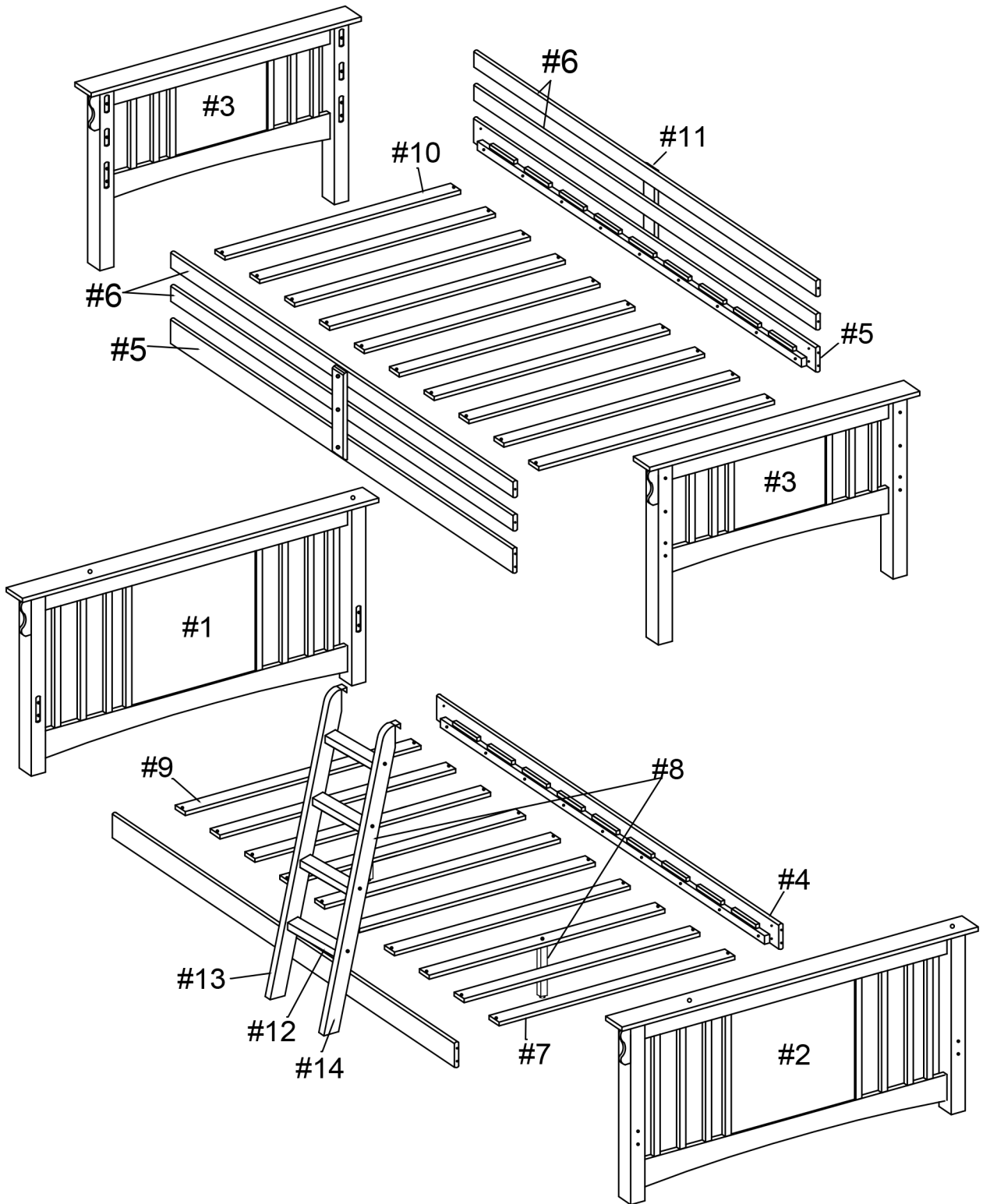

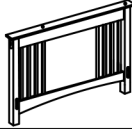
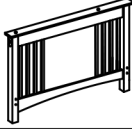
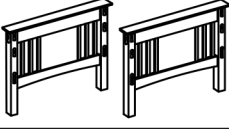
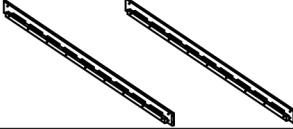
#I 1pc

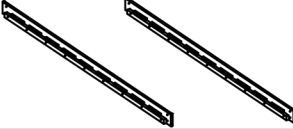

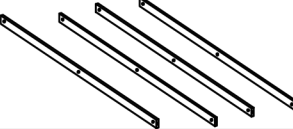
Allen Wrench 4mm

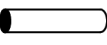
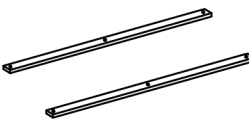
# Exploded View

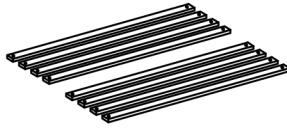
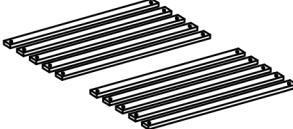
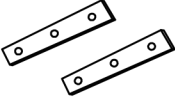
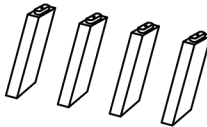

Carton	Disignation	Part	Hardware
	Lower Headboard (L)	#1 	
	Lower Headboard (R)	#2 	
	Upper Headboard/Footboard	#3 	
	Lower Side Rail	#4 	 #Ax24pcs  #Bx24pcs
	Upper Side Rail	#5 	 #Cx2pcs  #Dx40pcs
	Guardrail	#6 	 #Ex6pcs  #Fx4pcs
	Full Slat Kit	#7 	 #Gx8pcs  #Hx2pcs
	Support Leg	#8 	 #Ix1pc
	Full Slat Kit	#9 	
	Twin Slat Kit	#10 	
	Guardrail Support	#11 	
	Ladder Steps	#12 	

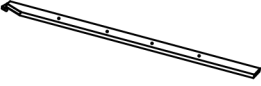
Carton	Disignation	Part		Hardware
	Ladder Rail (L)	#13		
	Ladder Rail (R)	#14		

# ASSEMBLY INSTRUCTIONS

## 1

- Part #1 x 1pc
- Part #2 x 1pc
- Part #4 x 2pcs
- Hardware #A x 8pcs
- Hardware #B x 8pcs

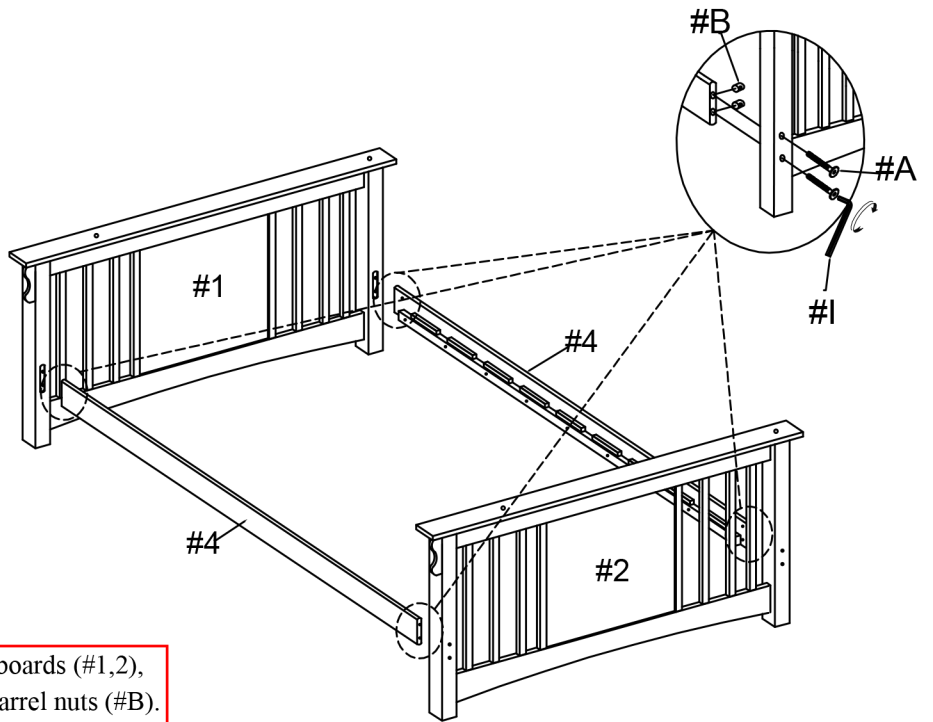

Align side rails (#4) to the lower headboards (#1,2), then secure by using bolts (#A) onto barrel nuts (#B).

## 2

- Part #7 x 1pc
- Part #8 x 1pc
- Hardware #C x 1pc

Align support leg (#8) to the slats (#7), then secure by using screws (#C).

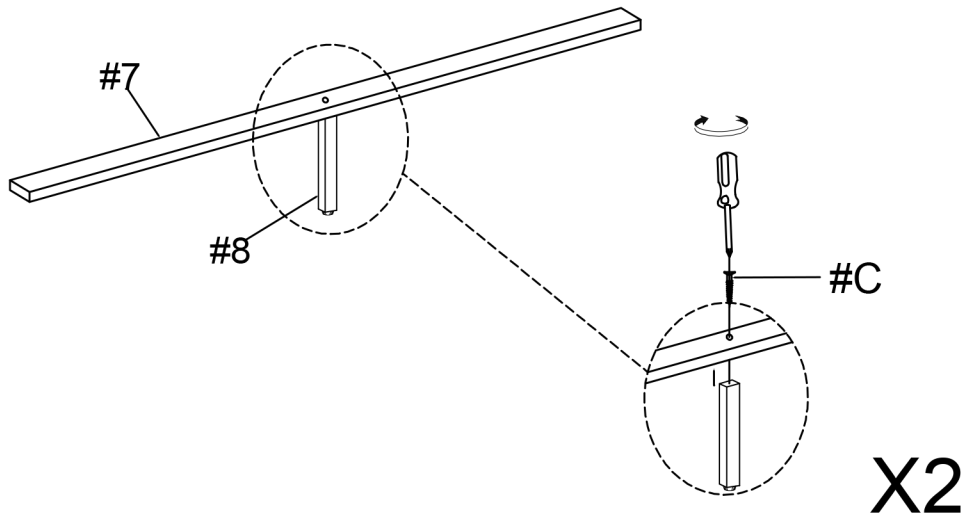

# ASSEMBLY INSTRUCTIONS

## 3

Part #7 x 2pcs

Part #9 x 8pcs

Hardware #D x 20pcs

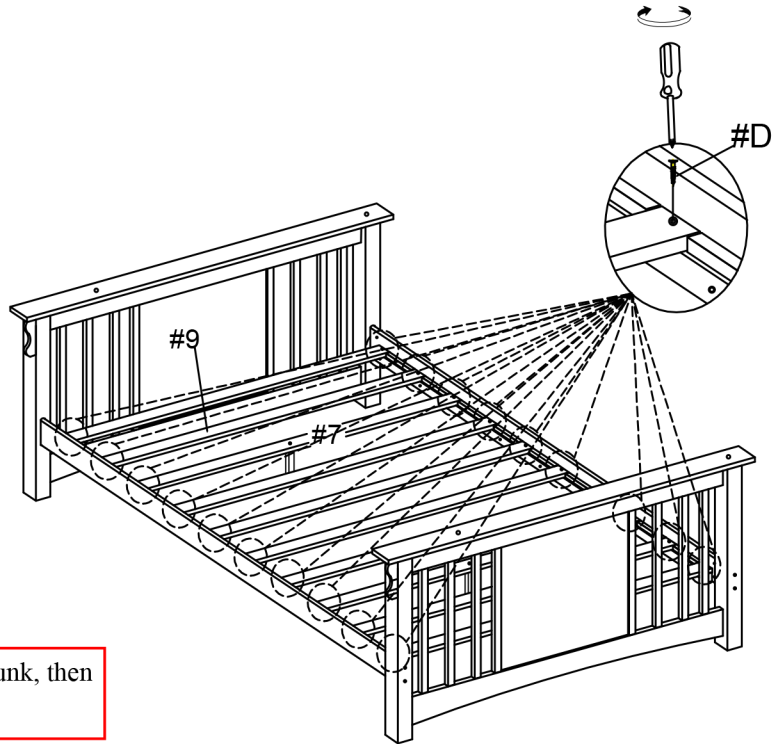

Align slats (#7,9) to the lower bunk, then secure by using screws (#D).

## 4

Part #3 x 2pcs

Part #5 x 2pcs

Part #6 x 4pcs

Hardware #A x 16pcs

Hardware #B x 16pcs

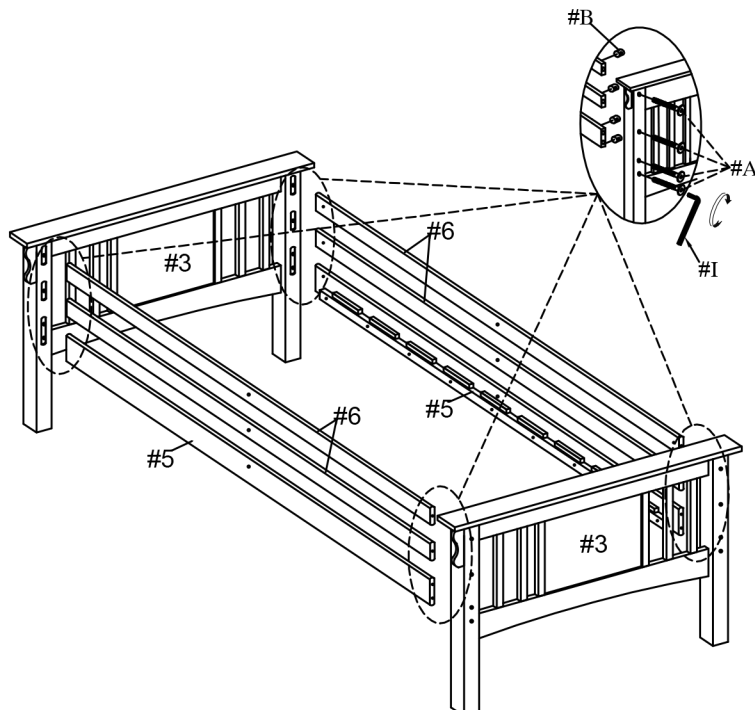

Align guardrails (#6) and side rails (#5) to the upper headboards (#3), then secure by using bolts (#A) onto barrel nuts (#B).

# ASSEMBLY INSTRUCTIONS

## 5

Part #11 x 2pcs  
Hardware #E x 6pcs

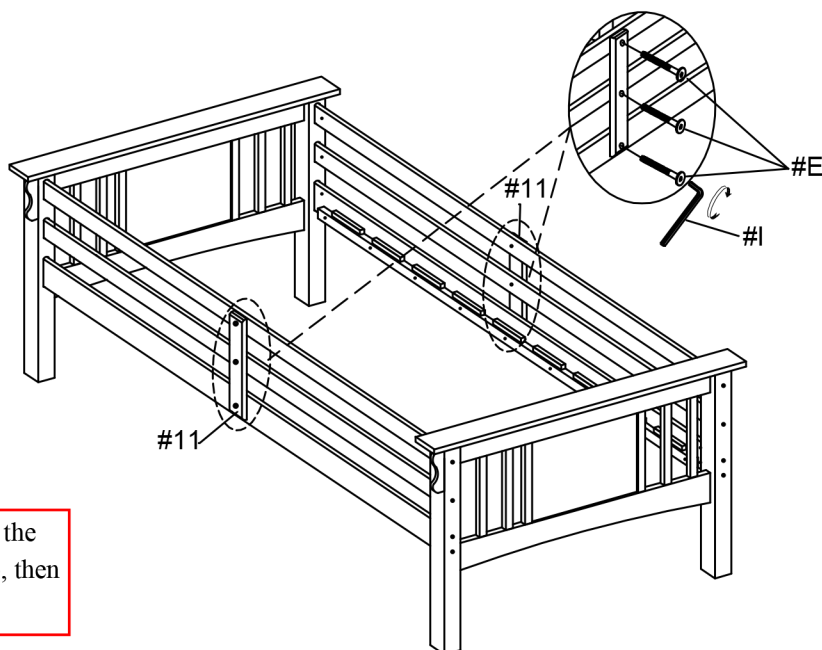

Align guardrail supports (#11) to the guardrails (#6) and side rails (#5), then secure by using bolts (#E).

## 6

Part #10 x 10pcs  
Hardware #D x 20pcs

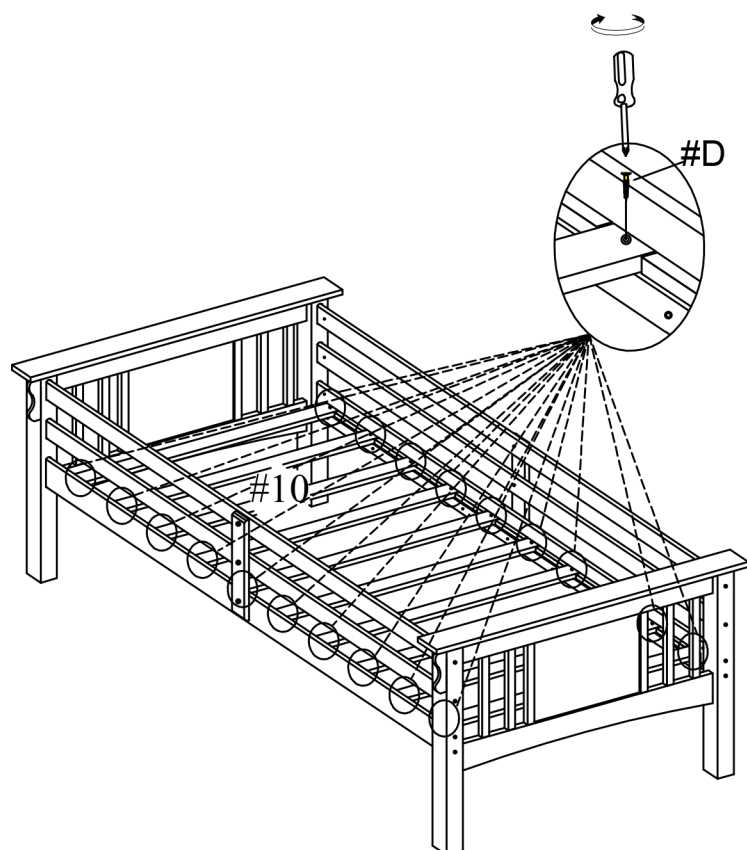

Align slats (#10) to the upper bunk, then secure by using screws (#D).

# ASSEMBLY INSTRUCTIONS

## 7

Hardware #F x 4pcs

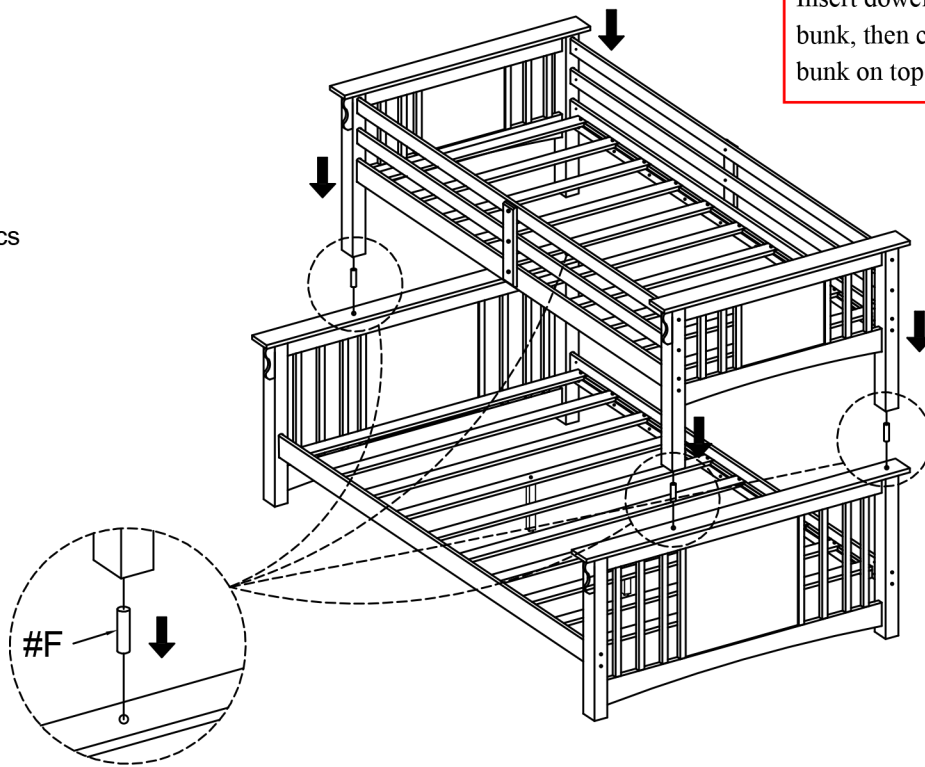

## 8

Part #12 x 4pcs

Part #13 x 1pc

Part #14 x 1pc

Hardware #G x 8pcs

Align ladder rungs (#12) to the ladder rails (#13,14), then secure by using screws (#G).

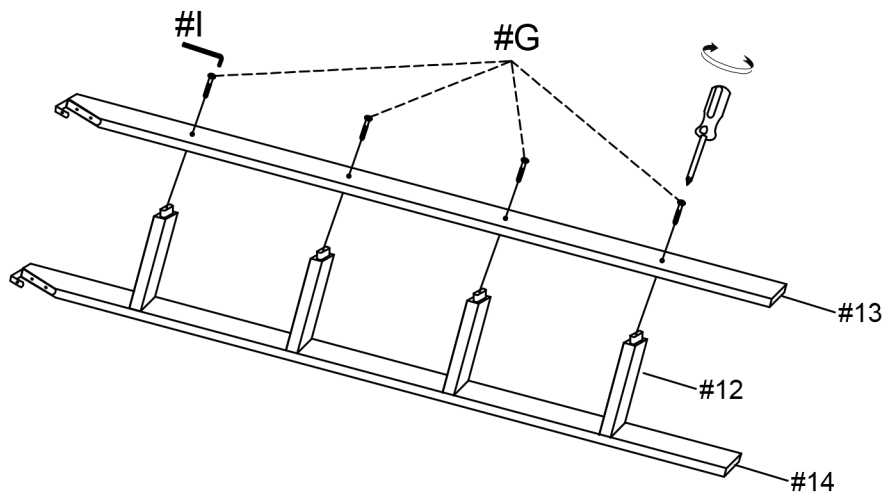

# ASSEMBLY INSTRUCTIONS

9

Hardware  x 2 pcs

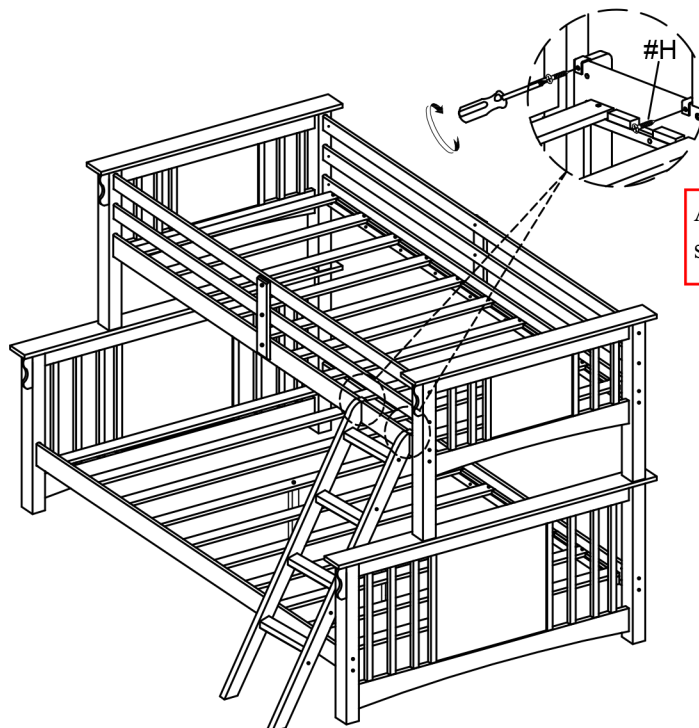

Align ladder to bunk bed, then secure by using screws (#H).

10

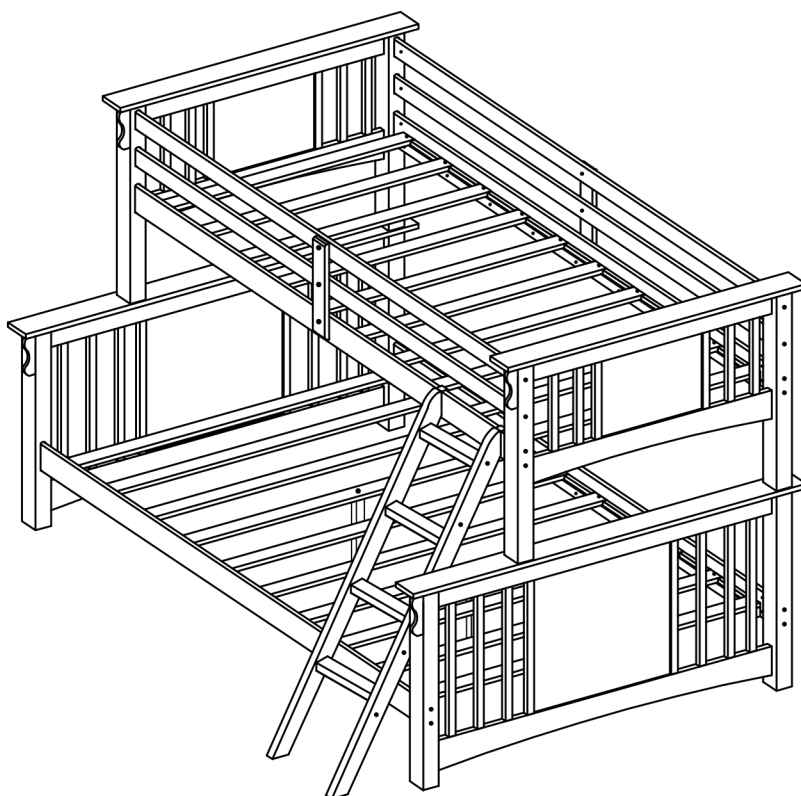

## ASSEMBLY COMPLETED



Please ensure the furniture rests on an even and flat surface. If the product wobbles or feels loose, double-check all bolts and/or screws are properly tightened and secured.

 **Keep this handy!**

Please retain this instruction manual and any order-related information for future reference.

 **Lift, don't drag!**

To avoid damage to product please always LIFT the product when transporting or adjusting the placement.

## Safety Warnings for Bunk Beds

1. Read and follow the information on the WARNINGS shown on the end structure of the upper bunk and on the carton.
2. Do not remove warning label from the bed.
3. Keep these instructions for future reference.
4. **IMPORTANT: Must use Bunkie mattress or Bunkie board.** The proper sizes for the **UPPER/LOWER TWIN-SIZE** Bunkie mattress or Bunkie board should be 74" long and 37½" - 38½" wide with no more than 6" thickness and for the **UPPER/LOWER FULL-SIZE** should be 74" long and 53" - 54" wide with no more than 6" thickness.
5. Surface of mattress must be at least 5 inches (127 mm) **BELOW** the upper edge of guardrails.
6. The **MAXIMUM** weight capacity for the upper bunk is not to exceed 175 lbs.
7. Do not allow children under 6 years of age to use the upper bunk.
8. Periodically check and ensure that the guardrails, ladder, handle and other components are in their proper position, free from damage, and that all connectors are tightened and secured.
9. **DO NOT** allow horseplay, rough playing or jumping on the beds and do not allow playing or hiding under the beds.
10. Always use the ladder for entering or leaving the upper bunk.
11. Do not use substitute parts. Contact the manufacturer or dealer for replacement parts.
12. Use of a nightlight may provide added safety precaution for a person using the upper bunk.
13. Always use the guardrails on both sides of the upper bunk.
14. If the bunk bed will be placed next to a wall, the guardrail that runs the full length of the bed should be placed against the wall to prevent entrapment between the bed and the wall.
15. The use of water or sleep flotation mattresses is prohibited.
16. No more than one person is allowed on the upper bunk at all times.



## **WARNING: STRANGULATION HAZARD**

Never attach or hang objects to any part of the bunk bed that are not designed for use with the bed. Objects such as hanger, hook, belt, bag, rope, string, etc. should not be used on or around the bunk bed.