

# DTB500

## Parcel drop box 20"

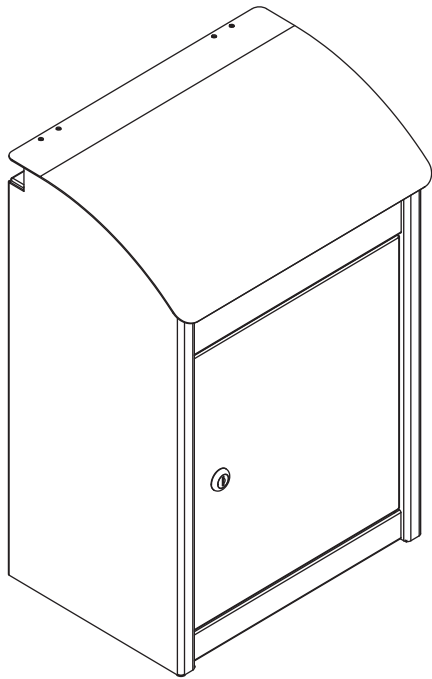

### Installation Instructions

### Installation Instructions



Always install the Parcel Box where it is easily accessible.

1. Set the Parcel Box in the desired location. Place the box on the wall and mark each location through the bottom of the box in each corner.
2. Remove the Parcel Box and drill holes in the marked places using the correct diameter and depth (3/8 inch drill bit, depth 2.36").
3. Re-position the Parcel Box and insert the bolts and washers so that it is tightly fixed to the wall ensuring that it is securely in place.

### Construction diagram & tools

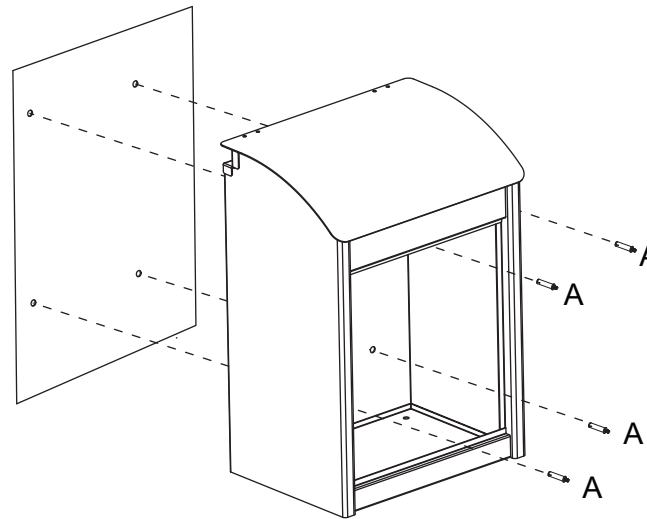
Installation will require 2 people. You will need a pencil, drill and spanner to install your parcel box.



A		M8*80 x 4
B		key x 2

Important: The fixtures provided may not be suitable for your property. Please ensure you use the appropriate fixtures for your construction. Please take due care when drilling into your walls, and damages to your property or the box is not the responsibility of the manufacturer or retailer.

### 1 YEAR LIMITED WARRANTY

This warranty applies to the drop box and not to the drop box it has been mounted to where damage may occur from the installation process.

This warranty covers defects in material and workmanship for this model from the original date of purchase. During the warranty period, we will replace any part which in our opinion is defective, if the drop box has not been subjected to tampering, vandalism, alteration, accidental damage after installation, roadside hazards, or improper use after delivery. Our obligation does not include the cost of transportation. We are not responsible for damage in transit, and claims for such damage should be presented to the carrier by the customer. This drop box is not warranted against misuse, use in extreme temperature conditions, exposure to damaging chemicals, or use in a commercial operation.

WE MAKE NO WARRANTIES, EXPRESSED OR IMPLIED, INCLUDING, WITHOUT LIMITATION, ANY WARRANTIES OF FITNESS OR MERCHANTABILITY EXCEPT AS EXPRESSLY SET FORTH ABOVE, WE SHALL NOT BE LIABLE FOR ANY ANTICIPATED OR LOST PROFITS, INCIDENTAL DAMAGES, CONSEQUENTIAL DAMAGES, COSTS, TIME CHARGES OR OTHER LOSSES INCURRED IN CONNECTION WITH THE PURCHASE, INSTALLATION, REPAIR OR OPERATION OF THE DROP BOX, AND WE DO NOT AUTHORIZE ANYONE TO ASSUME FOR US ANY LIABILITY IN CONNECTION WITH THE DROP BOX OR ANY PART THEREOF.