

ASSEMBLY INSTRUCTIONS

TOOLS REQUIRED:

Allen Wrench (Provided, Part G)

BEFORE YOU START:

1. Check the parts against the parts list to make sure all items are present.
2. Assemble your furniture on a soft, flat surface to avoid scratching the finish.
3. **CAUTION:** Do not over tighten screws, nuts or bolts during assembly.
4. Your furniture may require occasional tightening.

INSTRUCTIONS:

1. Turn the table top upside down on to a clean soft surface. Attach legs to the table top with Bolt (B), Lock Washer (E), Flat Washer (C) by Allen Wrench (G) as shown in Figure 1.
2. Attach the leg rails to the legs with Wood Dowel (A), Bolt (F), Lock Washer (E) and Flat Washer (D) by Allen Wrench (G) as shown in Figure 2.
3. Attach the remaining two leg to the assembly with Wood Dowel (A), Bolt (B), Bolt (F), Lock Washer (D), Flat Washer (C) and Flat Washer (D) by Allen Wrench (G) as shown in Figure 3.
4. Attach the stretcher to the leg rails with Wood Dowel (A), Bolt (F), Lock washer (E) and Flat washer (C) by Allen Wrench (G) as show in Figure 4.

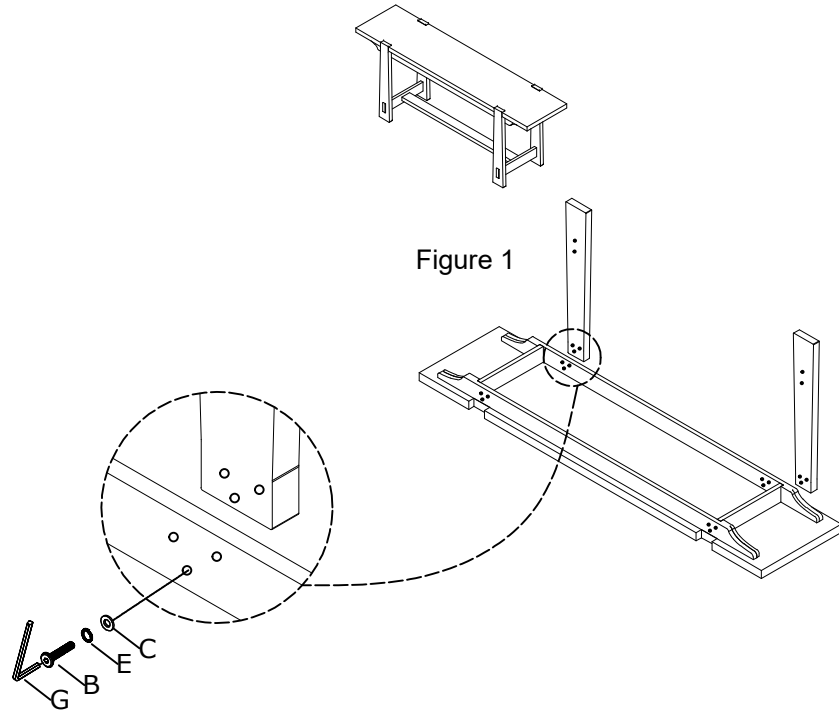

Figure 1

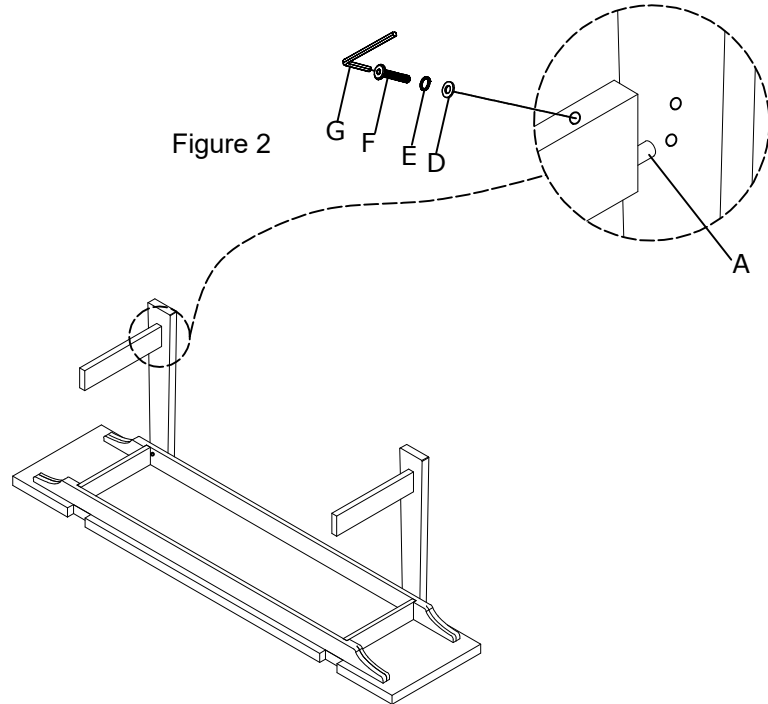









Figure 2

HARDWARE LIST

NO.	Drawing	Description	Q'TY
A		Wood Dowel Ø10*30mm	8 pcs
B		Bolt Ø1/4"*1 5/8"	12 pcs
C		Flat Washer Ø1/4"*19*1.5MM	14 pcs
D		Flat Washer Ø1/4"*13*1.5MM	4 pcs
E		Lock Washer Ø1/4"	18 pcs
F		Bolt Ø1/4"*2"	6 pcs
G		Allen Wrench 110*60*4MM	1 pc

ASSEMBLY INSTRUCTIONS

TOOLS REQUIRED:

Allen Wrench (Provided, Part G)

BEFORE YOU START:

1. Check the parts against the parts list to make sure all items are present.
2. Assemble your furniture on a soft, flat surface to avoid scratching the finish.
3. **CAUTION:** Do not over tighten screws, nuts or bolts during assembly.
4. Your furniture may require occasional tightening.

INSTRUCTIONS:

1. Turn the table top upside down on to a clean soft surface. Attach legs to the table top with Bolt (B), Lock Washer (E), Flat Washer (C) by Allen Wrench (G) as shown in Figure 1
2. Attach the leg rails to the legs with Wood Dowel (A), Bolt (F), Lock Washer (E) and Flat Washer (D) by Allen Wrench (G) as shown in Figure 2.
3. Attach the remaining two leg to the assembly with Wood Dowel (A), Bolt (B), Bolt (F), Lock Washer (E), Flat Washer (C) and Flat Washer (D) by Allen Wrench (G) as shown in Figure 3.
4. Attach the stretcher to the leg rails with Wood Dowel (A), Bolt (F), Lock washer (E) and Flat washer (C) by Allen Wrench (G) as show in Figure 4.

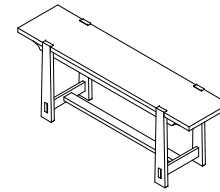

Figure 3

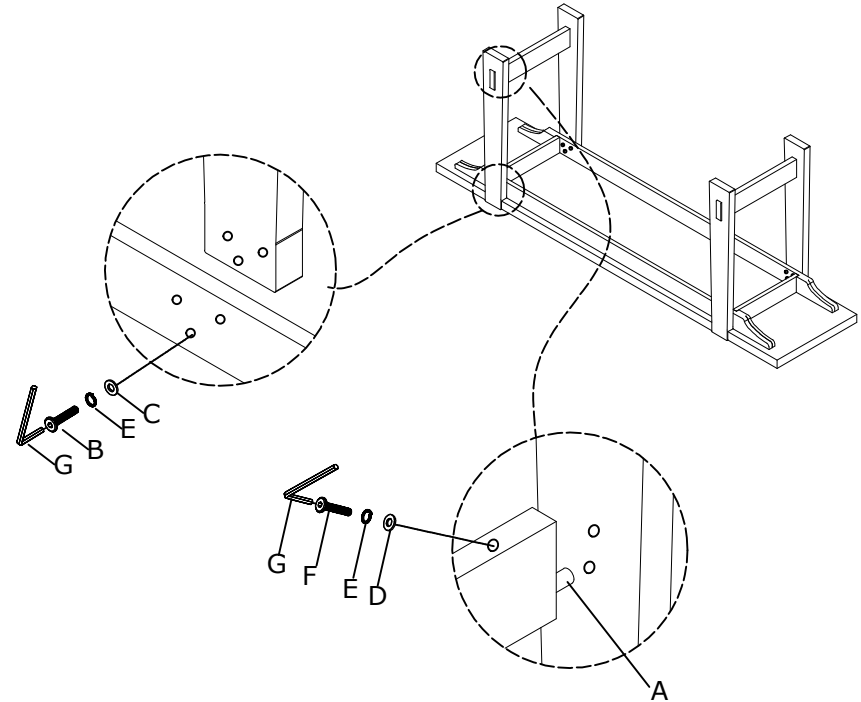
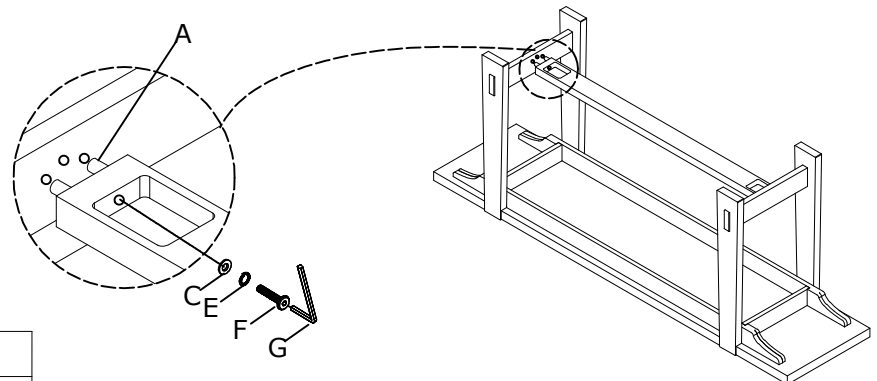

Figure 4



HARDWARE LIST

NO.	Drawing	Description	Q'TY
A		Wood Dowel Ø10*30mm	8 pcs
B		Bolt Ø1/4"*1 5/8"	12 pcs
C		Flat Washer Ø1/4"*19*1.5MM	14 pcs
D		Flat Washer Ø1/4"*13*1.5MM	4 pcs
E		Lock Washer Ø1/4"	18 pcs
F		Bolt Ø1/4"*2"	6 pcs
G		Allen Wrench 110*60*4MM	1 pc