

Bidet Toilet Seat USER MANUAL

Model No: 658G

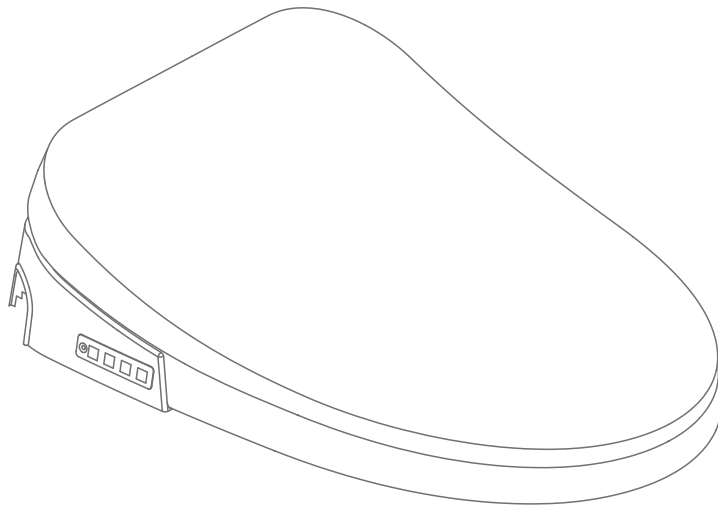

Edition: V 2021.09.01

Dear customers,

Thank you for purchasing our intelligent toilet series products, to ensure safety before using this product, please read this instruction carefully and keep it carefully for reference.

IMPORTANT SAFEGUARDS	02
PRODUCT FUNCTIONS	06
USING GUIDE	06
PACKING LIST	06
PRODUCT SIZE	06
SIDE BUTTON	06
TECHNICAL DATA	07
REMOTE CONTROL USER MANUAL	08
PRODUCT INSTALLATION METHODS	10
PRODUCT CLEANING AND MAINTENANCE METHODS	12
HOW TO DEAL WITH COMMON PROBLEMS	14

- Before beginning installation, read all instructions first. Save these instructions for future use.
- This product is subject to standard of UL 1431.

IMPORTANT SAFEGUARDS

When using electrical products, especially when children are present, basic safety precautions should always be followed, including the following:

READ ALL INSTRUCTIONS BEFORE USING

DANGER – To reduce the risk of electrocution:

1. Do not pour water or detergent on the power plug. It may cause fire, electric shock and other accidents.
Ne versez pas d'eau ou de détergent sur la prise d'alimentation. Cela peut causer un incendie, un choc électrique ou d'autres accidents.
2. Do not bring lit cigarettes or burning species close to the product. It may cause a fire.
N'amenez pas de cigarettes allumées ou d'espèces en feu à proximité du produit. Cela pourrait provoquer un incendie.
3. Please do not continue to use the product when the product fails. Please contact the after-sales service staff for maintenance. When the following situation occurs, please remove the power plug and close the inlet angle valve.

- ① Leakage from the inside of the product line;
- ② The product is unusually hot;
- ③ The product makes an abnormal sound and smell;
- ④ The product is burnt.

If the product is still used in the event of malfunction, it may cause problems such as fire, electric shock, water inflow in the room. (The normal life of this product is six years, the continued use beyond the service life may lead to accidents.)

Veillez ne pas continuer à utiliser le produit lorsqu'il tombe en panne. Veuillez contacter le personnel du service après-vente pour la maintenance. Lorsque la situation suivante se produit, veuillez retirer la fiche d'alimentation et fermer la vanne d'angle d'entrée.

- ① Fuite de l'intérieur de la ligne de produits;
- ② le produit est anormalement chaud;
- ③ le produit émet un bruit et une odeur anormaux;
- ④ le produit est brûlé.

Si le produit est encore utilisé en cas de dysfonctionnement, il peut causer des problèmes tels qu'un incendie, choc électrique, infiltration d'eau dans la pièce (la durée de vie normale de ce produit est de six ans, la poursuite de son utilisation au-delà de la durée de vie peut entraîner des accidents).

4. ① This product belongs to the electrical products, do not put it in places where there is water or the places of high humidity. When used in the bathroom, please install ventilation fan or ventilation port to keep the bathroom in good air circulation. Otherwise, it may cause a fire or electric shock.
② If the power cord is damaged, do not disassemble it yourself and must be replaced by the manufacturer or its service department or relative department.
① Ce produit est un produit électrique, ne le placez pas là où il y a de l'eau ou où l'humidité est élevée. e le mettez pas dans des endroits où il y a de l'eau ou des endroits très humides. Lorsqu'il est utilisé dans la salle de bain, veuillez installer un ventilateur ou un orifice de ventilation pour maintenir la salle de bain en bonne circulation d'air. Dans le cas contraire, cela pourrait provoquer un incendie ou un choc électrique.
② Si le cordon d'alimentation est endommagé, ne le démontez pas vous-même et il doit être remplacé par le fabricant ou son service après-vente ou le service concerné.

WARNING – To reduce the risk of burns, electrocution, fire, or injury to persons.

1. It is absolutely forbidden to disassemble, repair and transform this product by yourself.
It may cause fire, electric shock and other accidents.
Il est absolument interdit de démonter, réparer et transformer ce produit par vous-même.
Il peut causer un incendie, un choc électrique et d'autres accidents.
2. Only tap water can be used. Otherwise may cause infectious dermatitis and other diseases.
N'utilisez que de l'eau courante. Sinon, cela peut causer une dermatite infectieuse et d'autres maladies.

3. Forbiddance sitting on the seat for a long time, the seat temperature should be adjusted in low-grade, please note that low-temperature burns. The following personnel should set the seat temperature at low-grade when using the toilet.
- ① Children and elderly people who cannot adjust the temperature to the right degree.
 - ② Patients, persons with disabilities and other people who can not move freely.
 - ③ Lethargic crowd because of taking hypnotics (Such as sleeping pills, cold medicine, etc.) deep drinking and over fatigue.
- Ne vous asseyez pas sur le siège pendant une longue période, la température du siège doit être ajustée en bas de gamme, veuillez noter les brûlures à basse température. Les personnes suivantes doivent régler la température du siège à un niveau bas lorsqu'elles utilisent les toilettes.
- ① Les enfants et les personnes âgées qui ne peuvent pas régler la température au bon degré.
 - ② Les patients, les personnes handicapées et les autres personnes qui ne peuvent pas se déplacer librement.
 - ③ Les personnes léthargiques en raison de la prise d'hypnotiques (tels que les somnifères, les médicaments contre le rhume, etc.), de la consommation d'alcool et de la fatigue excessive.
4. Do not forcibly stretch the connecting pipe of the water supply pipe. Otherwise it may cause water leakage.
- Ne pas étirer de force le tuyau de raccordement de la conduite d'alimentation en eau. Sinon, cela pourrait provoquer des fuites d'eau.
5. Defecation clean function, a special cleaning function, only allowed to use one time whenever you use the toilet, non-repeated use!
- La fonction de nettoyage de la défécation, une fonction de nettoyage spéciale, ne peut être utilisée qu'une seule fois à chaque fois que vous utilisez les toilettes, usage non répété!
6. Do not rely on the seat cover or forcibly press the control panel. Otherwise it may result in malfunction or breakage. Forced application of force may cause seat cover and control panel damage, resulting in personal injury.
- Ne vous fiez pas à la housse du siège et n'appuyez pas de force sur le panneau de commande. Sinon, cela pourrait entraîner un dysfonctionnement ou une rupture.
- L'application forcée de la force peut endommager la housse du siège et le panneau de contrôle, ce qui peut entraîner des blessures.
7. Do not place containers containing liquid such as vials, cups, cosmetics, pharmaceuticals, etc. or small metal objects on top of the product. Inadvertent entry into the product may result in fire or electric shock.
- Ne placez pas de récipients contenant des liquides, tels que des flacons, des tasses, des cosmétiques, des produits pharmaceutiques, etc. Ou de petits objets métalliques sur le dessus du produit. L'entrée accidentelle dans le produit peut entraîner un incendie ou une électrocution.
8. Do not place the product in direct sunlight, otherwise the appearance of products may be aging deformation.
- Ne placez pas le produit à la lumière directe du soleil, sinon l'apparence du produit peut vieillir et se déformer.
9. People with disabilities, mental retardation, etc. (including children) need to use this toilet under supervision, do not let children play with this toilet.
- Personnes handicapées, retard mental, etc. (y compris les enfants) doivent utiliser ces toilettes sous surveillance, ne laissez pas les enfants jouer avec ces toilettes.
10. Do not use the toilet to flush expect shit, urinate and toilet paper, or it may cause toilet jam, sewage overflow.
- N'utilisez pas la chasse d'eau pour vous attendre à ce que vous chiez, urinez et utilisez du papier toilette, car cela pourrait provoquer un blocage des toilettes ou un débordement des eaux usées.
11. Please do not hit the ceramic to prevent damages that result in leakage.
- Veuillez ne pas frapper la céramique afin d'éviter des dommages qui pourraient entraîner des fuites.
12. Please do not use in the environment below 3°C.
- S'il vous plaît ne pas utiliser dans un environnement inférieur à 3 °C.
13. When installing the inlet angle valve, please tighten firmly. Otherwise it will lead to water leakage.
- Lors de l'installation de la vanne d'angle d'entrée, veuillez la serrer fermement. Sinon, cela entraînera des fuites d'eau.

14. Prevent damage caused by freezing. Freezing can cause damage to the water hose and product interiors and cause water leakage.
Prévenir les dommages causés par la congélation. La congélation peut endommager le tuyau d'eau et à l'intérieur du produit et entraîner des fuites d'eau.
15. When traveling for long periods of time or when not in use, please unplug the power plug from the outlet.
En cas de long voyage ou de non-utilisation, veuillez débrancher la prise de courant.
16. This product is only for bathroom, and should not be used for any purposes other than the ones described in this manual. Otherwise maybe cause to fire, electric shock, personal injury or malfunction.
Ce produit est destiné uniquement aux salles de bains et ne doit pas être utilisé à d'autres fins que celles décrites dans ce manuel. Sinon, cela peut causer un incendie, un choc électrique, des blessures Ou l'échec.
17. Do not allow urine and other contaminants to touch the smart toilet. Doing so may cause odor or cause malfunction.
Ne laissez pas l'urine et les autres polluants entrer en contact avec les toilettes intelligentes. Cela peut causer des odeurs ou causer des problèmes.
18. Do not forcibly close the seat and seat cover. It is necessary to avoid the collision of the seat lid and the seat cover when turning them. Otherwise maybe cause malfunction.
Don't clip to the fingers while seat and seat cover switch, otherwise maybe cause bruise.
Ne fermez pas de force les sièges et les housses de siège. Évitez la collision du couvercle de siège et du couvercle de siège lors de la rotation. Sinon, cela peut entraîner un échec. Ne pas couper à Interrupteur de siège et de siège lorsque le doigt, sinon il peut causer des ecchymoses.

SAVE THESE INSTRUCTIONS

DANGER – Improper use of the grounding plug can result in a risk of electric shock.

1. Do not use loose power outlet. It may cause a fire or electric shock.
N'utilisez pas de prise de courant mal fixée. Cela peut causer un incendie ou un choc électrique.
2. Please use the power outlet within the specified conditions (110-120V~, 13A, 60Hz socket).
Do only use 110-120V~ power supply. Using power beyond the socket regulations may cause the socket to heat up and cause a fire.
Veuillez utiliser la prise de courant dans les conditions spécifiées (prise 110-120V ~, 13A, 60Hz). Utilisez seulement l'alimentation électrique de 110-120V~. L'utilisation d'une alimentation électrique non conforme à la réglementation sur les prises peut entraîner un réchauffement de la prise et provoquer un incendie.
3. Do not damage the power cord and seat wire.
 - ① Do not damage, do not process, do not heat;
 - ② Do not force bending, do not curly tied, do not pull;
 - ③ Do not put heavy objects on the power cord and the seat lid connection, ignoring product damage and continuing to use may result in fire, electric shorts and other conditions.
N'endommagez pas le cordon d'alimentation et le fil du siège.
 - ① ne pas endommager, ne pas traiter, ne pas chauffer;
 - ② ne pas forcer la flexion, ne pas lier, ne pas tirer;
 - ③ ne pas poser d'objets lourds sur le cordon d'alimentation et le raccord du couvercle du siège, en ignorant les dommages causés par le produit et en continuant à l'utiliser, ce qui pourrait provoquer un incendie, des court-circuits électriques et d'autres problèmes.
4. Please check if grounding is done. A product that is not grounded may cause an electric shock in the event of a malfunction or leakage.
Veuillez vérifier si la mise à la terre est effectuée. Un produit qui n'est pas mis à la terre peut provoquer un choc électrique en cas de dysfonctionnement ou de fuite.
5. Unplug the power plug when lightning occurs.
Débranchez la prise d'alimentation lorsque la foudre se produit.
6. For external maintenance, unplug the power plug from the socket for safety reasons. Otherwise maybe get an electric shock.
Pour la maintenance externe, débranchez la prise d'alimentation de la prise pour des raisons de sécurité. Sinon, il peut être électrocuté.

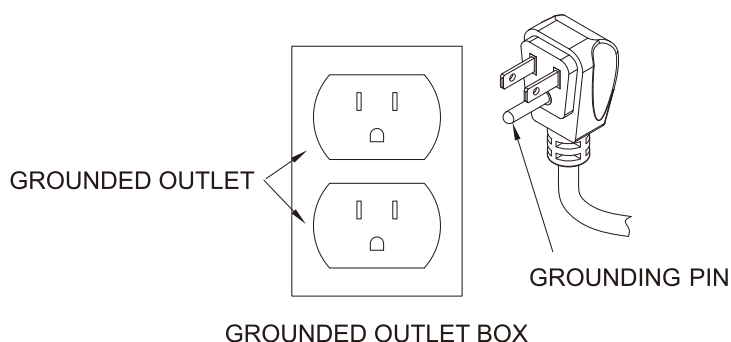

This device complies with Part 15 of the FCC Rules. Operation is subject to the following two conditions:

(1) this device may not cause harmful interference, and (2) this device must accept any interference received, including interference that may cause undesired operation.

Caution: The user is cautioned that changes or modifications not expressly approved by the party responsible for compliance could void the user's authority to operate the equipment.

Note: This equipment has been tested and found to comply with the limits for a Class B digital device, pursuant to part 15 of the FCC Rules. These limits are designed to provide reasonable protection against harmful interference in a residential installation. This equipment generates uses and can radiate radio frequency energy and, if not installed and used in accordance with the instructions, may cause harmful interference to radio communications. However, there is no guarantee that interference will not occur in a particular installation. If this equipment does cause harmful interference to radio or television reception, which can be determined by turning the equipment off and on, the user is encouraged to try to correct the interference by one or more of the following measures:

- Reorient or relocate the receiving antenna.
- Increase the separation between the equipment and receiver.
- Connect the equipment into an outlet on a circuit different from that to which the receiver is connected.
- Consult the dealer or an experienced radio/TV technician for help.

This device contains licence-exempt transmitter(s)/receiver(s) that comply with Innovation, Science and Economic Development Canada's licence-exempt RSS(s). Operation is subject to the following two conditions:

- (1) This device may not cause interference.
- (2) This device must accept any interference, including interference that may cause undesired operation of the device.

L'émetteur/récepteur exempt de licence contenu dans le présent appareil est conforme aux CNR d'Innovation, Sciences et Développement économique Canada applicables aux appareils radio exempts de licence. L'exploitation est autorisée aux deux conditions suivantes:

- (1) L'appareil ne doit pas produire de brouillage;
- (2) L'appareil doit accepter tout brouillage radioélectrique subi, même si le brouillage est susceptible d'en compromettre le fonctionnement.

Product functions

Heated Seat, Soft Night Light, Energy Saving, Deodorization, Warm Air Drying, Rear Wash, Front Wash, Defecation Wash, Menstrual, Cold & hot SPA, Children Wash, Nozzle Self-clean, One Touch, Adjustable Water Temperature, Adjustable Seat Temperature, Adjustable Air Temperature, Adjustable Water Pressure.

Using guide

Please follow up the process below before product operation.

1. Turn on the valve.
2. Plug the power cord into electrical inlet.
3. If power button indicator lights, the bidet seat is good to use.

Standby Model

By pressing the power button on the control panel.

1. Short touch: stop washing or drying model.
2. Long press: start or stop standby model when it's in off seat model.

Rear Wash

Touch rear wash button when you are in seat, and start washing process.

Front Wash

Touch Front wash button when you are in seat, and start washing process.

Warm Air Drying

Touch air drying button when you are in seat, and start washing process. It's off in 4 minutes.

Packing list

No.	Name	Quantity	No.	Name	Quantity
1	Bidet Seat	1	6	Prefilter	1
2	User Manual	1	7	Remote Controller	1
3	Fixed movable plate	2	8	Water Supply Pipe	1
4	Mounting Screw Set	2	9	T valve	1
5	Remote Expansion Nut	2	10	Remote Screw	2

Product size

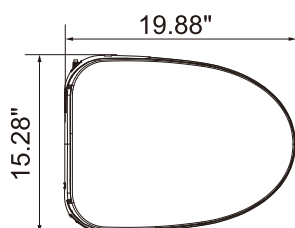

Side button

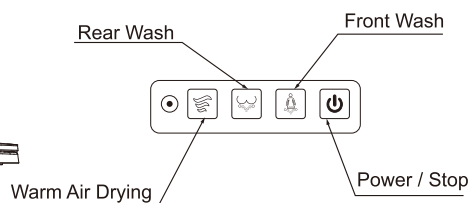

Technical data

Rated voltage		110-120V~	
Rated frequency		60Hz	
Rated power		1100W (15°C±1°C inlet water temperature)	
Water supply mode		Directly connected to the channel	
Ambient temperature		About 3°C to 40°C	
Water supply temperature		About 3°C to 35°C	
Water pressure range		11.6Psi-108.8Psi	
Safety devices		Seated sensor, water over-pressure protection device	
Decontaminating apparatus	Heating method		Instant heating
	Warm water temperature		Four grades (Room temperature to 40°C)
	Spray volume	Buttock cleaning	About 0.5 to 0.8L/min
		Women-only	About 0.5 to 0.8L/min
	Warm water heater		1100W
	Safety applause		Temperature sensor, temperature fuse, temperature jumper, flowmeter
Drying device	Wind speed		>4m/s
	Air temperature		Four grades (Room temperature to 40°C)
	Drying heater		250W
	Safety devices		Double-sheet-metal switch, temperature fuse
Deodorizing device	Deodorant		Activated carbon
	Power consumption		1.5W
Thermal seat	Seat temperature		Four grades (Room temperature to 40°C)
	Seat heater		28W
	Safety devices		Temperature sensor, temperature fuse
	Switch structure		Seat and cover with damping slow down device

Rated power: at room temperature 20±5°C, inlet water static pressure is 0.18+0.02Mpa.
The average power of turning on the cleaning function and working steadily for one cleaning cycle at the inlet temperature of 15±1°C.



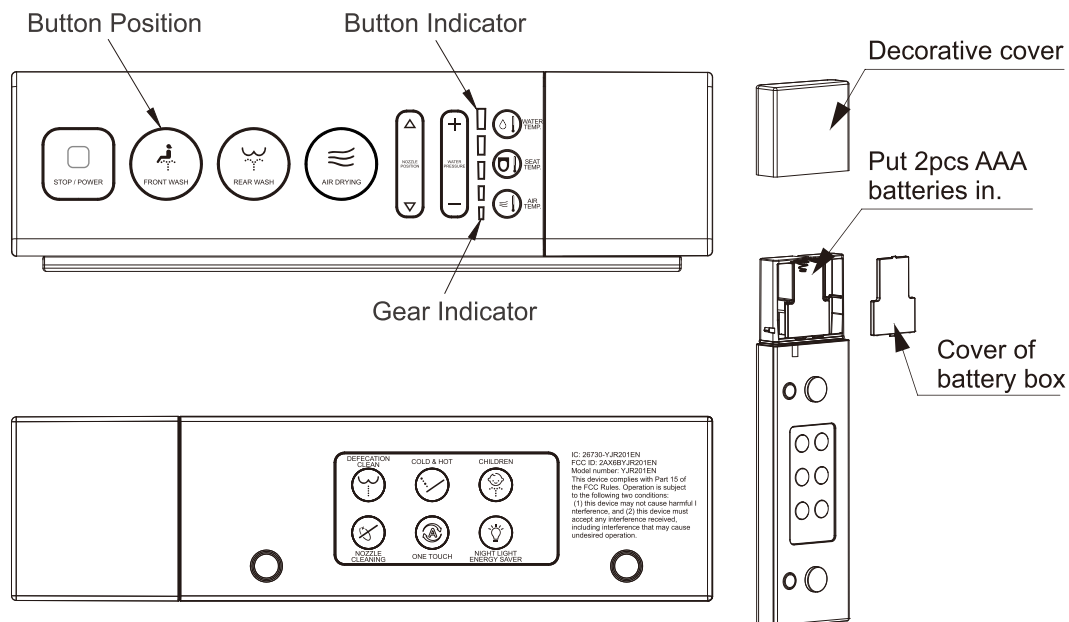

Remote control user manual



Remote control code matching steps:

1. Power off the bidet,
2. Press and hold STOP/POWER and NOZZLE CLEANING buttons simultaneously for about 2 seconds , until the 4 indicator lights are turned on and flashing.
3. Turn on the bidet
4. When the remote control is connected to the bidet , the third and fourth indicator lights will be on, it means code matching succeeded. If not succeeded , try again after 15 seconds.

1. Main function

 <p>Rear Wash Short press: start wash buttocks. Double press: start / stop mobile wash.</p>	 <p>Warm Air Drying Short press: start warm air drying.</p>
 <p>Front Wash Short press: start female wash. Double press: start / stop mobile wash.</p>	 <p>Stop Current Work Short press: quit current wash or drying. Long press: turn the toilet power on or off.</p>

2. Parameter adjustment

<p>+</p> Adjust water pressure Short press "+", water pressure grade +1, short press "-", water pressure grade -1. <p>△</p> Adjust tube front and rear position. Short press "△", tube position grade +1, short press "▽", tube position grade -1.	<p>🪑</p> Adjust seat temperature Short press: cyclically adjust seat temperature. <p>💧</p> Adjust water temperature Short press: cyclically adjust water temperature. <p>🌬️</p> Adjust air temperature Short press: cyclically adjust air drying temperature.
--	---

3. Auxiliary functions



<p>🔄</p> One-touch completes rear wash and warm air drying. Short press: start automatic "One Touch" mode. <p>💩</p> Defecation clean: clean water column shoots into the end of the anorectal to help defecation. Short press: start defecation clean. <p>👶</p> Children: customized the appropriate parameters for children, wash the buttocks. Short press: start children care cleaning.	<p>🌡️</p> Cold & Hot SPA: water alternately massages and washes. Short press: start cold & hot massage. Press continuously: turn mobile cleaning on or off. <p>💡</p> Night light during night Short press: turn night light on or off. Press continuously: enter or exit energy saving mode. <p>🧼</p> Nozzle cleaning: when not seated, stick out the nozzle for daily cleaning. Short press: start nozzle cleaning.
---	---

4. Others

Energy saving

After the user leaves the seat, intelligently adjust the heating power of the seat.

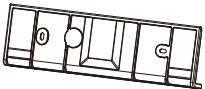
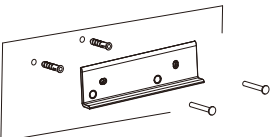
Remote control installation steps

- ①  remove 3M protective film
- ② 
 - A. Determine the screw position.
 - B. Put the expansion nut.
 - C. Remove the sticker on the back of the remote control holder, Stick it to the right place on the wall.
 - D. Screw on.
- ③ 

↓



Insert the remote control into the holder
- ④  Completed

Product installation methods

1. Precautions before installing the toilet

- ① This product uses the 110-120V~ voltage, electrical construction requires the commission of professional electrical companies.
- ② When using this product, tap water pressure must be 0.08Mpa - 0.75Mpa.
- ③ After the installation, plug the product power into the socket. When you hear a "D", it means that the product is powered on and the self-test is completed.
- ④ Please use the water supply pipe attached to the toilet for installation. Do not use the old water supply pipe, otherwise it may affect the performance of the product.
- ⑤ Please do not use cloth cover or cushion on the seat, otherwise it may cause seat induction not good.
- ⑥ In low-temperature environment, please leave the product in a warm room for 2 hours before installation to prevent internal moisture from damaging the machine.
- ⑦ The following picture shows the toilet standard specifications of the product that can be installed.

Dimensions of the toilet that can be installed

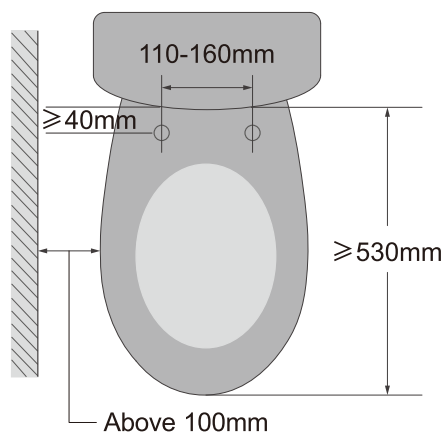

- This series toilet seat cover not suitable for children-toilet and arch water-tank toilet (as below pictures shown)



One-piece water tank rear arch toilet



Installable water supply valve

2. The method of separating the installed toilet seat and fixed water purification filter.

- ① Turn the hose valve (supply stop) to the right and lock it, and then separate the water tank from the water pipe valve (supply stop) with the water supply pipe.
- ② Detach the installed toilet seat. (Disassemble the product according to the original method of toilet seat.)

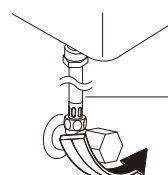

Pipe of water tank

- Take proper care of seat cover, bolt, nut seal. They will be needed when moving or reinstalling.

- ③ Connect the T valve to the water stop valve (supply stop), and then separately connect the water tank and the seat water supply pipe to the assembled T valve.

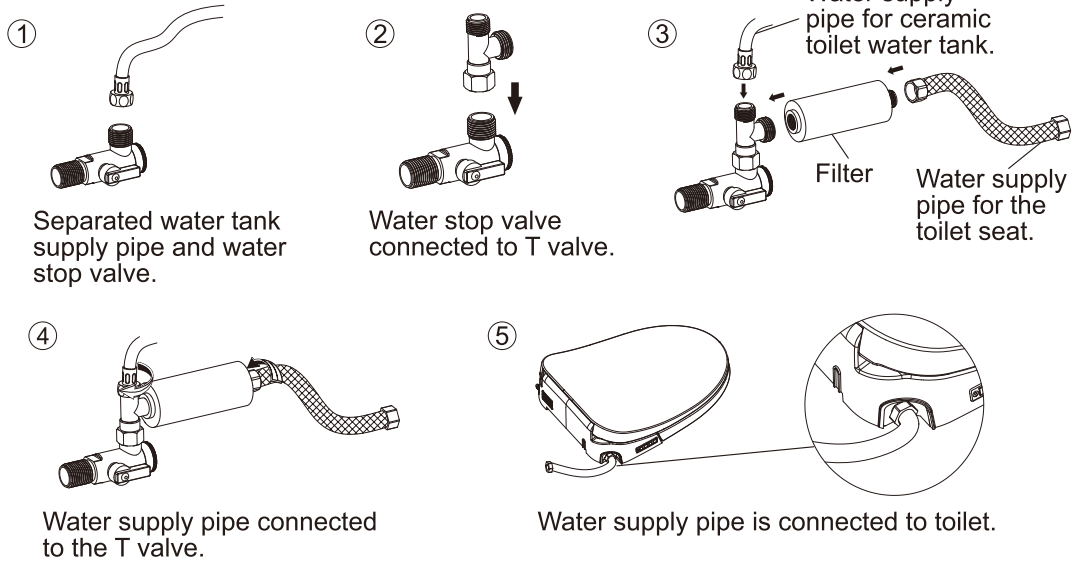

3. Fixing method of fixed plate and intelligent toilet

- ① Insert expansion nut into toilet seat holder. Place mounting plate on toilet seat. Stainless steel screws are threaded in turn Square gasket, moving fixed plate, fixed on the installation plate fixed plate, the installation plate fixed plate fastening on the toilet.

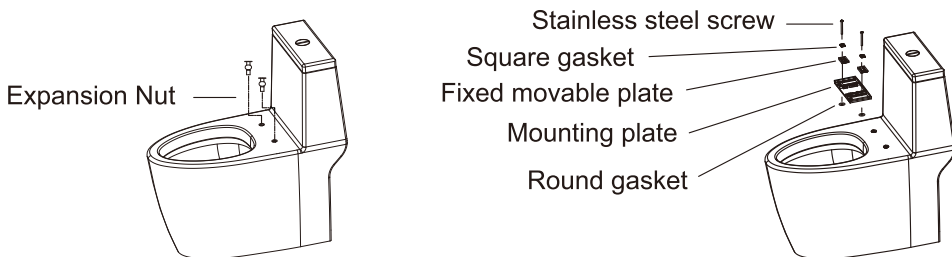

- ② Insert the mounting plate assembly into the center of the rear of the smart toilet seat cover. If there is "click" sound, it is in normal installation state.

- Do not flip the toilet during operation.

- ③ Sway the smart toilet seat cover back and forth, and left and right to check whether it will come off.

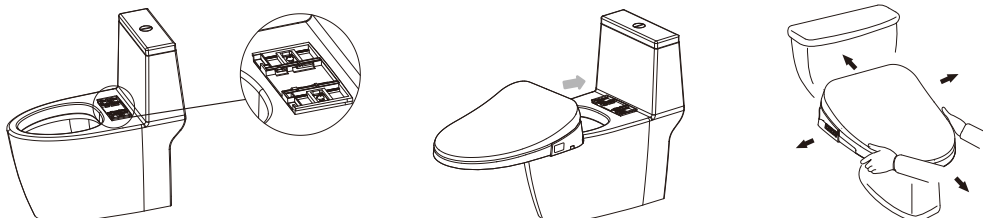

4. Smart toilet disassembly method

Press the removal button on the side of the smart toilet and pull the product forward in this state, then the toilet is separated from the seat.

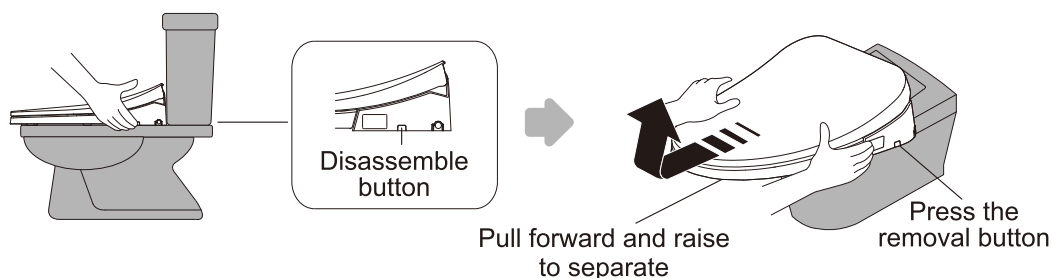

5. Instruction for testing after installation

After the installation is complete, it must be commissioned and record the results of the installation points in the following form.

Check items				Results
Is it connected to the 110-120V~, 13A, 60Hz power outlet? Grounding the equipment is required.				
Is the power outlet loose?				
Is the water supply opened?				
Tighten the various joints (such as the filter, water supply pipes and screw, etc) ?				
Is the indicator light on?				
The spraying nozzle is leaking? After wiping the nozzle, check if there is any water leakage.				
The various functions of the product is normal: Rear wash and front wash, water temperature and seat temperature adjustment, cold & hot SPA, soft lighting and nozzle cleaning, etc. Are they normal use? The above series of actions should be checked.				
Date of installation		Name of the installation store		Installer

Product cleaning and maintenance methods

Warning: waterproof toilet cleaning precautions

- Do not clean the product with your hands in case of damage or failure, to avoid secondary failure.
- Do not use hydrochloric acid detergent, thinner, bleach, benzene or strong detergent to clean the surface of the toilet. Do not allow pesticides, air fresheners and deodorants to stick to the toilet bowl.

• **The body discoloration, cracking and damage caused by the use of the above-mentioned reagents, even within the warranty period also need to paid the services.**

1. Nozzle cleaning

- ① On the machine power mode, do not sit on the seat.
- ② Press "Nozzle cleaning", entering the manual cleaning nozzle mode.
(Can not activate "nozzle cleaning" mode when seated)
- ③ Please use soft brush or soft cloth when cleaning.
- ④ After the cleaning is completed, press the stop button or in the seating state, the cleaning tube is automatically retracted.

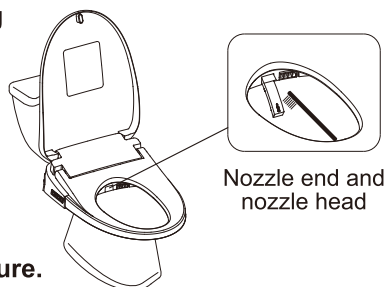

- **Warning: do not force out or push into the cleaning tube during cleaning, or it may lead to machine failure.**

2. Toilet appearance cleaning method

Clean the toilet when the toilet is in fixed state.

- ① Please use sponge or soft cloth stained with neutral detergent to clean the surface of the toilet.
- ② Please use a soft cloth to clean the nozzle cover and dry nozzle cover. Be careful not to damage the rubber seal.
- ③ Spray water on the toilet and clean it.
- ④ After cleaning, clean the whole cotton cloth.



- **Do not use strong detergent containing hydrochloric acid. Do not use deodorant. Refer to cleaning precautions.**

3. How to clean the gap between smart cover and ceramic toilet.

- ① Press the disassemble button below the right side of the toilet to detach it.
- ② Clean the nozzle cover and the drying nozzle cover under the toilet bowl with a soft cloth or and clean the lower part of the toilet bowl and the ceramic seat toilet with a tool for cleaning.
- ③ After cleaning, clean the whole a cotton cloth and install the toilet.

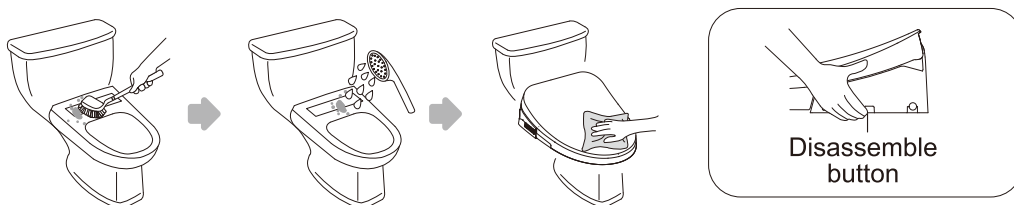

4. Seat toilet management methods in winter

In order to prevent freezing in winter, please follow the following methods to manage.

- ① Check whether the power plug is properly inserted into the socket.
- ② When the bathroom has no heating device, please use cloth to wrap connecting pipes or other insulating materials for insulation.
- ③ When the toilet will not be used for a long time in winter, please unplug the power plug and discharge the water inside the body.

Note:

Please tighten the filter firmly, otherwise it may cause water leakage.

Do not grab the filter net too strongly as it may distort or rupture.

When blockage blocks the filter, the pressure of the flushing water may not be enough, so please change the filter regularly. The filter is usually replaced every six months. If you do not regularly change the filter, the buyer shall be responsible for the consequences of the malfunction. Please clean the toilet filter regularly once in three months.

We recommend that you do not use detergent when cleaning.

Clean it directly with tap water.

Trouble shooting

Problems		Check	Handling
Functions does not work at all.		The seat sensing area uses cloth cover, mat and other items.	Please remove the cloth cover, mat and other items.
		Power is cut.	Please wait for power recovery.
		Socket is loose or poor contact.	Plug in, ensure good power supply.
		Whether the power reset button is pressed.	Please press the power button on the toilet.
Flushing	Water doesn't come out.	No water.	Please wait for the water supply to resume.
		Water inlet valve is clogged with dirt.	Open the inlet valve.
		Filter is clogged with dirt.	Please change or clean the filter.
		Whether the water supply tube is bent and clogged.	Eliminate the water supply pipe bending.
	Flushing power is not strong enough.	Water pressure is set at low-grade.	Please adjust the water potential power by "button description" on the remote control.
		Filter is clogged with dirt.	Please change or clean the filter.
		Clean the nozzle to see if there is any blockage.	Please clean the nozzle.
	Water temperature is not high enough.	Whether the water temperature is set at low or normal temperature.	Please reset the water temperature by "button description" on the remote control.
	No water supply when flushing.	Press the "Rear Wash" or "Front Wash" key for about 60s, the machine will automatically stop.	Please click "Rear Wash" or "Front Wash" key again.
	Toilet Seat	The heated seat is not heating.	Thermal seat's heating strength is set in the low or off state.
The toilet is set in the energy-saving state.			Please press the power button to exit energy-saving state.
Whether the power outage.			Please wait for power recovery.

Thank you for choosing us

The company is committed to product development and improvement. If there is any difference between the original manual and the improved one, please read the corresponding version of the manual. We apologize for any inconvenience.

尺寸：18.3x25.7cm

材质：封面和内页材质：80g双胶纸

装订工艺：骑马钉