

INSTALLATION INSTRUCTIONS

DeerValley®

Undermount & Drop-in Kitchen Sink

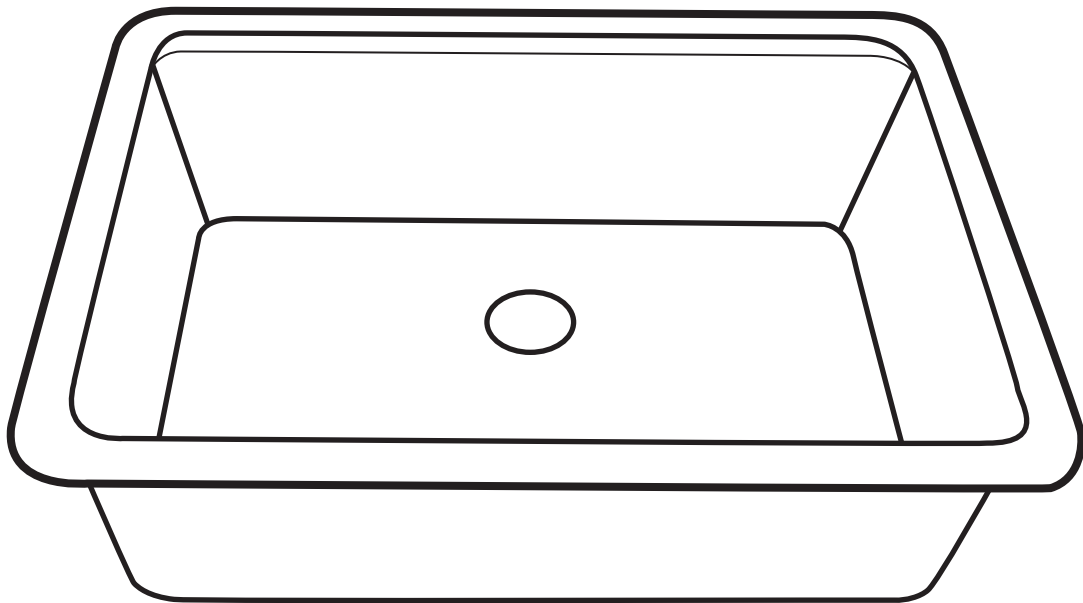

Illustrations for reference only, actual product may vary.



Prior to Installation:

- Inspect kitchen sink to ensure no damages have occurred while in shipping.
- Observe all plumbing and building codes in accordance with your state and local requirements.
- Additional floor and wall preparations may be necessary to avoid damage to the product.
- Make sure to purchase the correct cabinet for your undermount sink.
- Installation with laminate countertop not recommended.
- All dimensions are nominal! Be sure to measure your cabinet to installation.
- Kitchen sinks are very heavy. Get assistance lifting the sink.

General Recommendations:

Please read installation and maintenance instructions thoroughly before installing the kitchen sink.
Be sure to use proper tools and always wear proper personal safety accessories for your protection.

**If you have any questions or concerns
please contact us:**

(312) 626-9466
service@deervalleybath.com

RECOMMENDED TOOLS AND MATERIALS (NOT INCLUDED)

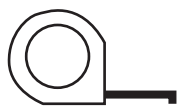

Tape Measure



Pencil



Clean Rags



Level

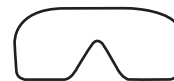

Safety Glasses

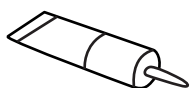

Construction Adhesive

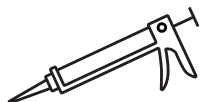

Silicone Sealant Adhesive



Screws

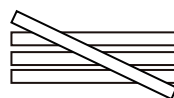

Suitable Support Framing Material



Drill and Drill Bits



Screwdriver

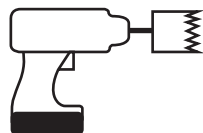

Hole Saw



Jigsaw



Painter's Tape

Note: The actual tools and materials required may vary depending on your specific installation conditions.

INSTALLATION OPTIONS

This sink can be installed in two ways:

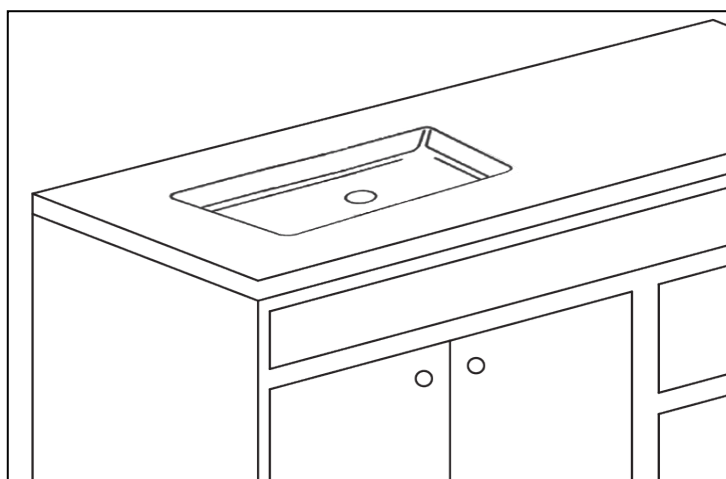

Undermount Installation

For a seamless look beneath the countertop.

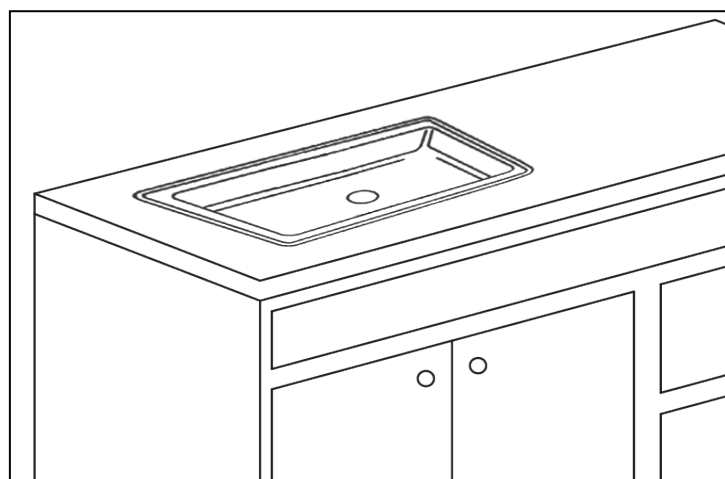

Drop-In Installation

For easy installation from above the countertop.

Illustrations are for reference only; please refer to the actual product.

UNDERMOUNT INSTALLATION

Step 1: Prepare the Base Cabinet

Measure the sink and base cabinet, and ensure the cutout or opening is at least 3 inches wider than the sink to allow proper installation and adjustments.

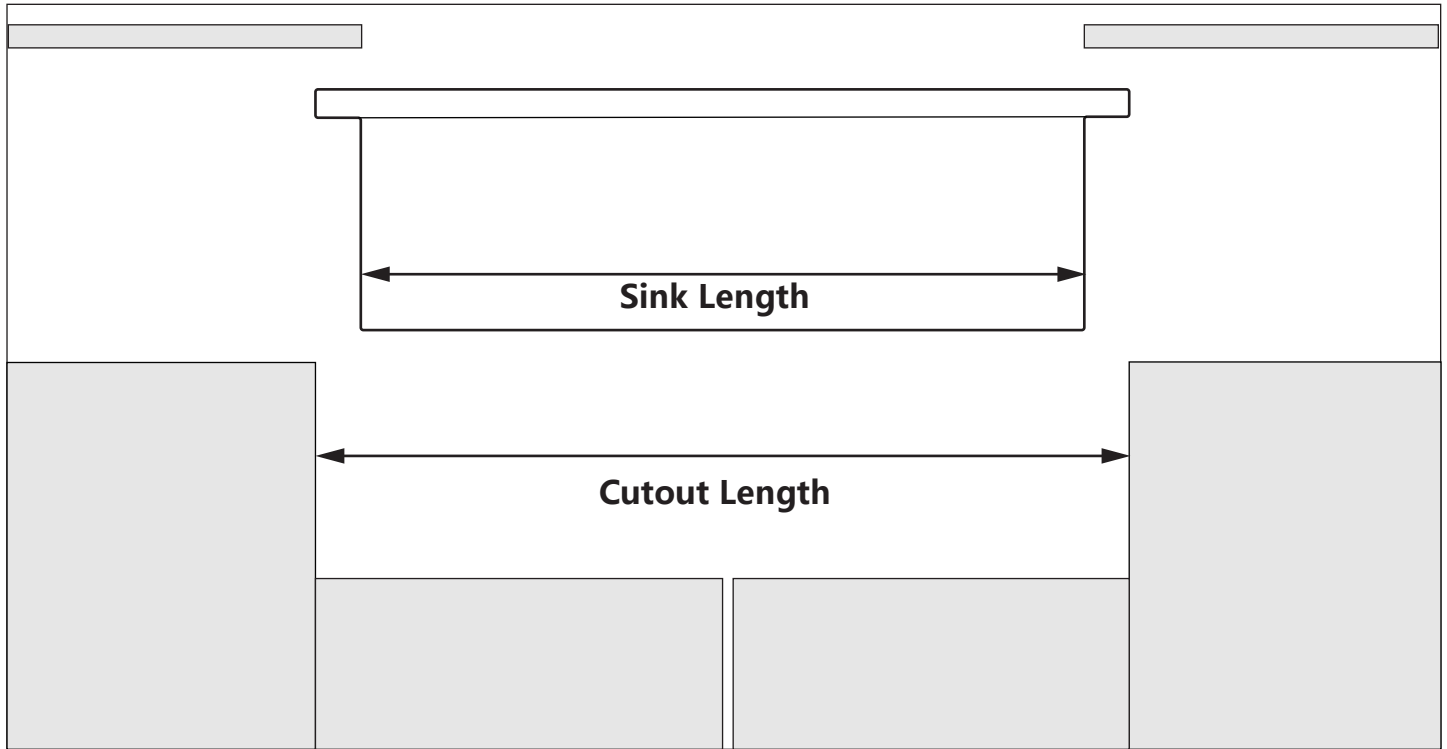

Step 2: Undermount Installation Options

The sink can be installed in three different ways:

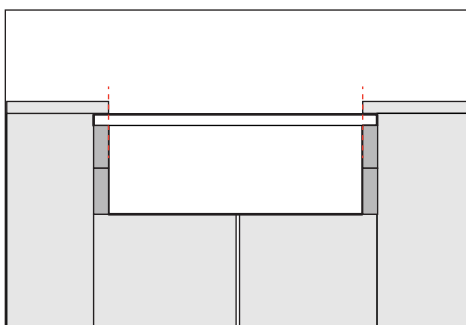

Flush Installation – Install the sink flush with the countertop surface, with no overhang or reveal.

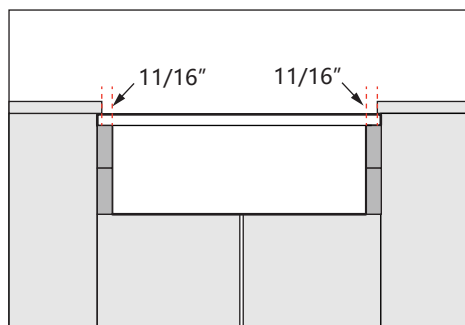

Positive 11/16" Reveal Installation – The sink rim is exposed 11/16" beyond the countertop opening.

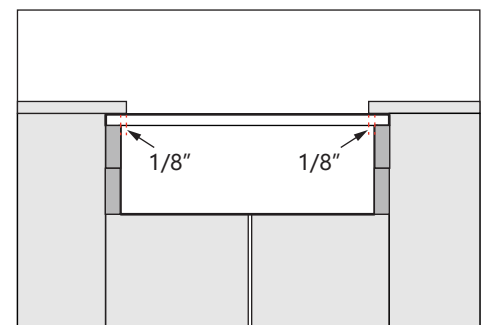

Negative 1/8" Overhang Installation – The sink overhangs the countertop opening by 1/8".

Illustrations are for reference only; please refer to the actual product.

Step 3: Support Framing Construction

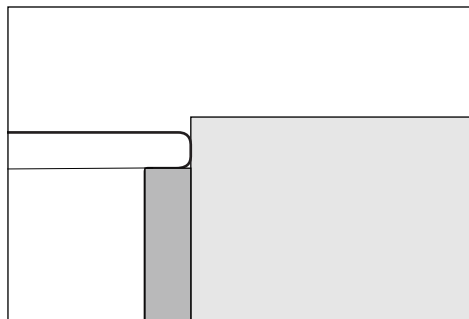

1. Use appropriate fasteners and techniques to ensure the support framing can hold at least 300 pounds.

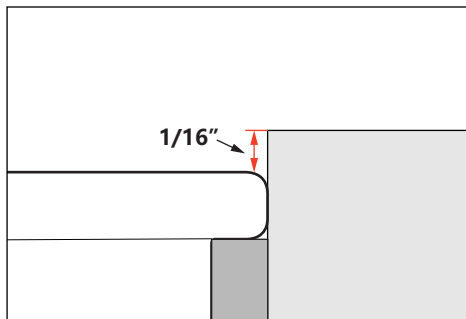

2. The sink top must not extend above the cabinet top; it should sit about 1/16 inch below the top edge.

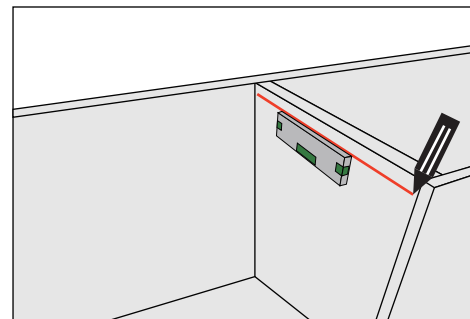

3. Measure down the sink height from the cabinet top, mark this distance on both inside walls, and verify the marks are level.

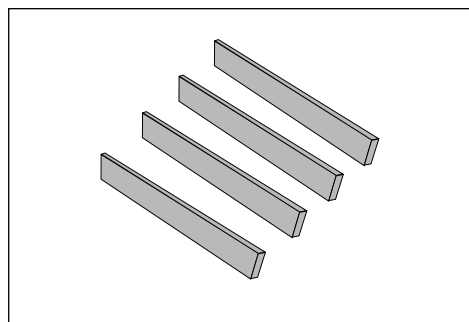

4. Cut four lengths of support framing to fit along the cabinet walls.

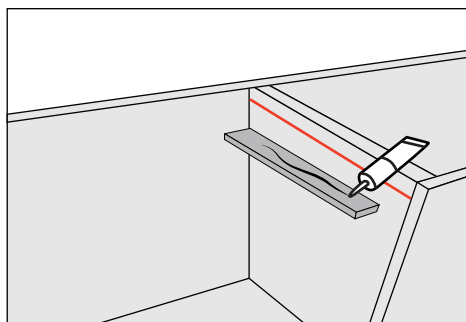

5. Apply construction adhesive to each support.

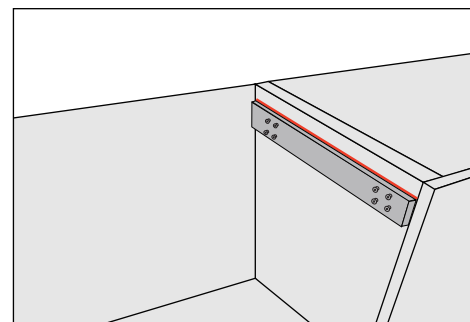

6. Secure the supports with screws at the previously marked positions, ensuring the tops of the supports are aligned with the marks.

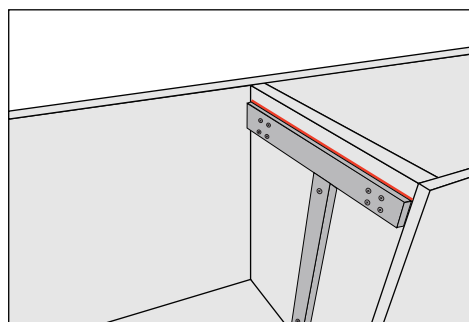

7. Install the vertical supports (customized according to the actual cabinet dimensions) and secure them with screws.

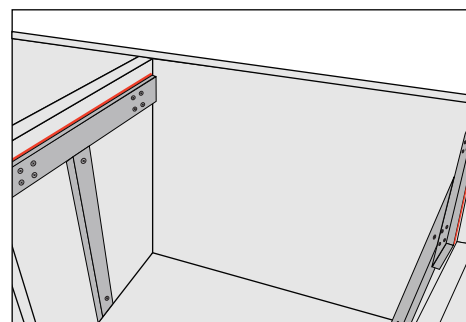

8. Install the remaining supports in the same way. These supports ensure that the sink top will align with the cabinet top during installation.

Illustrations are for reference only; please refer to the actual product.

Step 4: Sink Installation

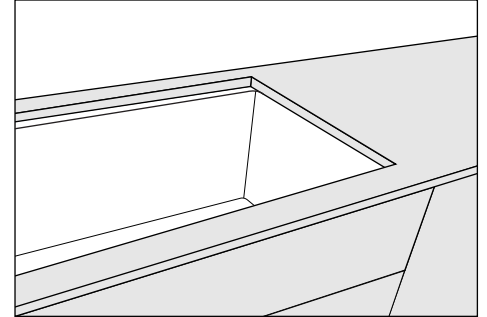
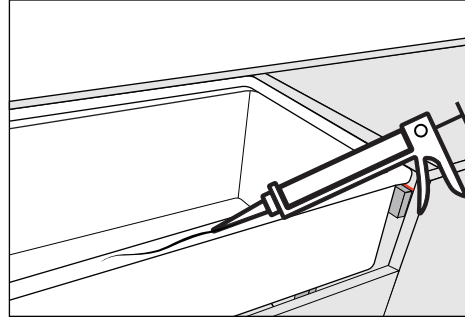
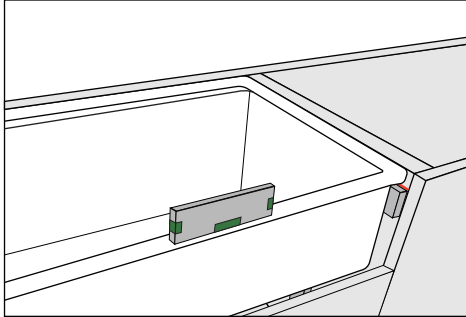

1. Lower the sink onto the supports and verify it is fully supported and level.
2. Make adjustments if needed by sanding the opening or adding wood filler strips or shims.

3. Apply silicone sealant around the sides of the sink.

4. Install the countertop over the sink opening according to the countertop manufacturer's instructions.
5. Wipe away any excess sealant and allow it to dry.

Step 5: Faucet Installation

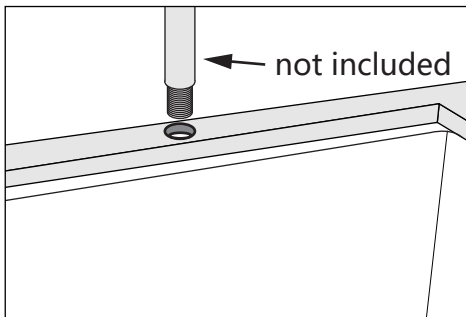

Install the faucet (not included) as needed, ensuring sufficient space is reserved on the countertop for installation.

Illustrations are for reference only; please refer to the actual product.

DROP-IN INSTALLATION

Step 1: Mark the Cutout

1. Place the sink upside down on the countertop and adjust it to the desired position. Use a pencil to trace the outer edge of the sink.
2. Draw another line inside the outer edge, about 0.39" inch inward, as the cutting line.

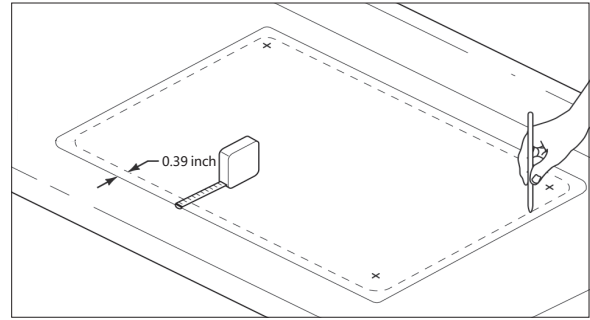
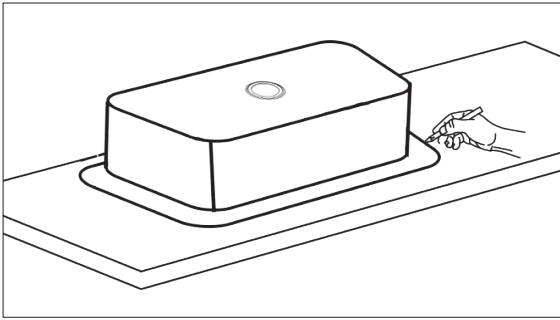

Step 2: Countertop Cut-Out

1. Drill a starter hole inside the marked cutting line.
2. Use a jigsaw saw to cut along the inner pencil line and create the opening.
3. Place the sink in the opening for a trial fit to ensure proper placement.

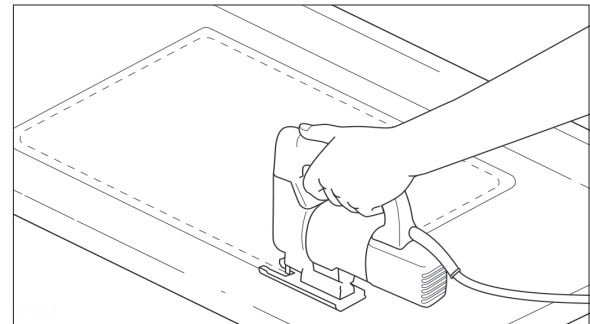
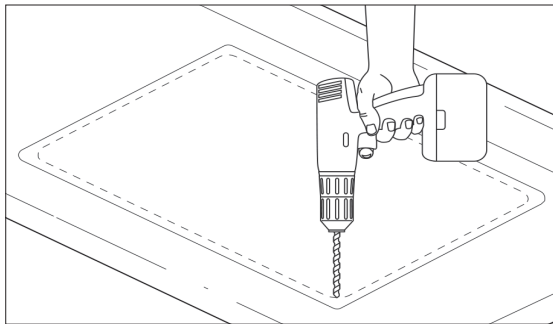

Step 3: Apply Silicone Sealant

Apply silicone sealant (not included) evenly to the underside of the sink edge.

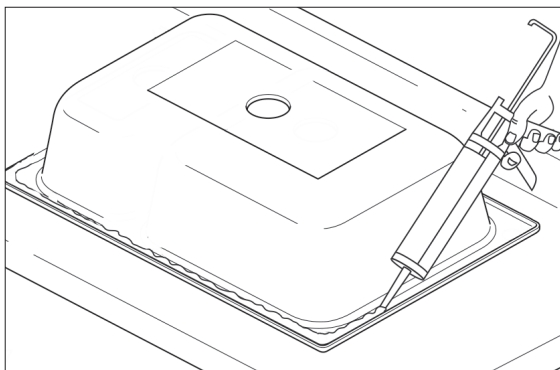

Illustrations are for reference only; please refer to the actual product.

Step 4: Set the Sink into the Opening

1. Carefully place the sink into the countertop opening, pressing the edges down so the sealant makes full contact.
2. Verify that the sink is properly aligned and sits securely in the opening.

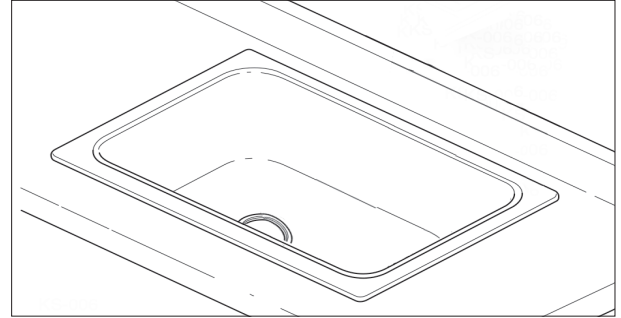
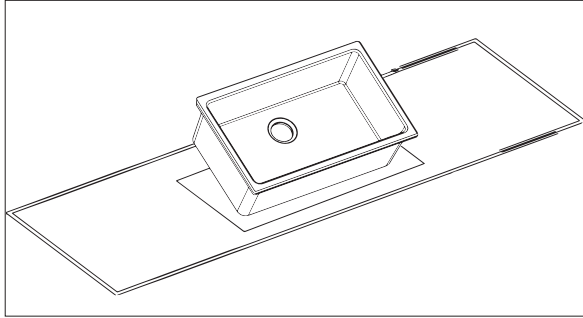

Step 5: Faucet Installation

Install the faucet (not included) as needed, ensuring sufficient space is reserved on the countertop for installation.

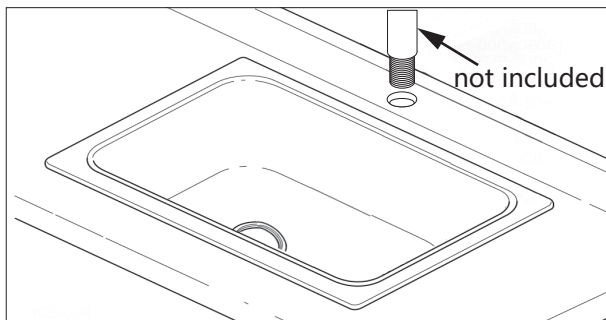

Illustrations are for reference only; please refer to the actual product.

CLEANING & MAINTENANCE GUIDE

1. Daily Cleaning

- Rinse the sink thoroughly with warm water after each use to remove food particles and debris.
- Wipe with a soft cloth or sponge using a mild dish soap.
- Avoid letting acidic or staining substances sit on the surface for long periods.

2. Deep Cleaning

- 1) Prepare a solution of warm water and baking soda or a non-abrasive cleaner.
- 2) Apply the solution to the sink surface and scrub gently with a soft cloth or sponge.
- 3) Rinse thoroughly with clean water and dry with a soft towel.
- 4) For stubborn stains, apply white vinegar or a ceramic-safe cleaner, leave for a few minutes, then rinse and wipe.

3. Avoid

- Do not use steel wool, abrasive pads, or harsh chemicals that may scratch or damage the surface.
- Avoid dropping heavy objects into the sink to prevent chipping or cracking.
- Do not allow prolonged contact with bleach or strong acids.

4. Maintenance Tips

- Dry the sink after each use to prevent water spots and mineral deposits.
- Use a sink mat or protective grid to reduce the risk of scratches.
- Periodically polish the ceramic surface with a ceramic-safe polish to maintain shine.

5. Stain Removal

- 1) For coffee, tea, or rust stains, apply a paste of baking soda and water.
- 2) Let it sit for 10–15 minutes, then gently scrub and rinse.
- 3) Repeat if necessary.

6. Long-Term Care

- Avoid exposing the sink to direct heat or extreme temperature changes.
- Do not cut food directly on the sink surface.
- Inspect the sink edges and drain periodically for signs of wear or damage.

Illustrations are for reference only; please refer to the actual product.

LIMITED WARRANTY COVERAGE

1 YEAR LIMITED WARRANTY

DeerValley products are made with quality materials and excellent craftsmanship to provide the customers a long-lasting product. In the case of any defects in materials or craftsmanship under regular use were inspected in the first one year of delivery, DeerValley will provide replacement parts at no charge, or at its option, replace any product or part of the product that is deemed defective, under normal installation, use, service and maintenance. This warranty applies only to the original purchaser. Proof of purchase will be required in the case of a claim. **SCRATCHES ARE NOT COVERED UNDER WARRANTY.**

The manufacturer warrants this product to be free of manufacture defects during the above mentioned warranty time. Please keep a copy of the original invoice as proof of purchase.

DeerValley will, as its option, (1) repair or replace the defective part(s) or product(s) at no charge; (2) issue a refund of the original purchase price of the product(s) (Valid within 30 days from the date of delivery); or (3) issue a credit to be applied toward the purchase of a new DeerValley product shipping/delivery charges may apply and are in DeerValley sole discretion.

DeerValley recommends the installations to be made by a licensed, professional plumber. DeerValley will not be held responsible for any damage or product failure due to improper installation, misuse, or failure to use a licensed professional. DeerValley is not responsible for any removal or installation cost.

This limited warranty shall not apply to goods which have been subject to accident, negligence, improper installation, product abuse, product misuse, or use of cleaners containing abrasives, alcohol or other organic solvents, whether performed by a contractor, service company, or yourself, are excluded from this warranty.

DeerValley responsibility under this limited warranty is limited to only to replacement parts and no other costs. DeerValley will not be responsible for labor charges and/or damage incurred by installation, repair or replacement, nor for any indirect incidental or consequential damages, losses, injury or costs of any nature relating to this product Except as provided by law, this limited warranty is in lieu of and excludes all other warranties, conditions, and guarantees, whether expressed or implied, statutory or otherwise, including without restriction those merchantability of fitness for use.

RESPONSIBILITIES OF OTHERS

Inspecting the unit prior to installation is the responsibility of the installer or building contractor who acts on behalf of the user. They are responsible for ensuring the unit is free of defect or damage.

Notices are placed on and in the unit and on the shipping carton advising the installer of this responsibility.

In the event of a problem, the unit must not be installed. DeerValley is not responsible for failures or damage that could have been discovered, repaired, or avoided by proper inspection and testing prior to installation.

Damage occurring in transit is the responsibility of the carrier. The user or installer **MUST** open the crate and inspect the unit for damage when it is delivered. If damage is discovered, it must be reported immediately to the seller and the carrier in writing, and an inspection requested. Failure of the carrier to respond should be reported to the seller and the carrier. Your freight claims should be filed promptly thereafter.

LIMITATIONS AND EXCLUSIONS

This warranty does not cover instances of negligence, misuse, abuse, improper installation, carelessness, accident, hard water or mineral deposits, exposure to corrosive materials, misapplication, damages caused by improper maintenance, alteration of the product, or failure to follow care or installation instructions enclosed with your product. The warranty becomes invalid if the DeerValley product undergoes any alterations or if attempts are made to carry out repairs using unauthorized accessories or parts from DeerValley.

DeerValley will not be liable for loss of use of the DeerValley products, inconvenience, or any other incidental or consequential costs, expense or damages. Please note that some states do not allow the exclusion or limitation of incidental damages.

DISCLAIMER

Except as expressly provided, there shall be no warranty or obligation, express or implied, oral or statutory. No dealer or other person has the authority to make any warranties or representations concerning DeerValley or its products. In no event shall DeerValley be held responsible for any such warranties or representations.

WARRANTY SERVICE

NOTE: When requesting warranty, be sure to have the following:

- Copy of original invoice
- Date of installation
- Description and pictures of defect
- Model number or description of model

To obtain warranty service and replacement part, please contact DeerValley Customer Service. DeerValley will determine whether to repair or replace your product, issue a refund, or issue a credit.