

STEP 5

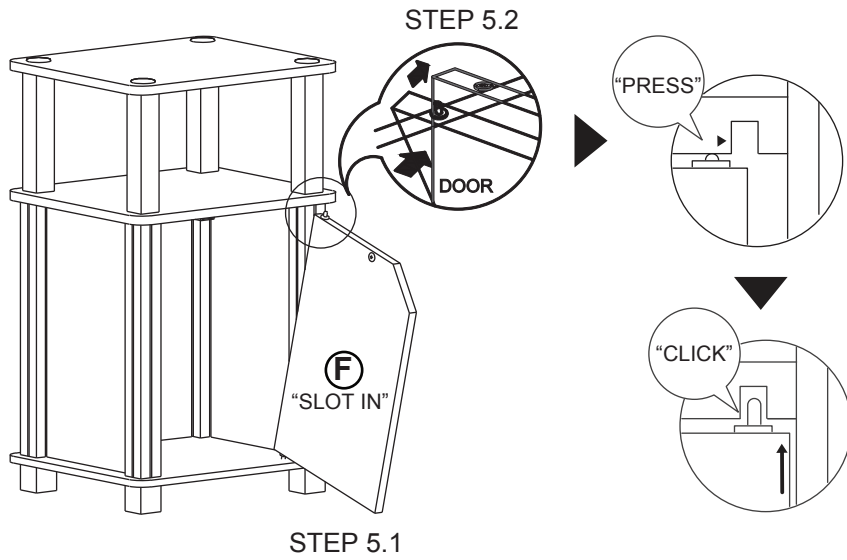

Recommended Maximum Weight

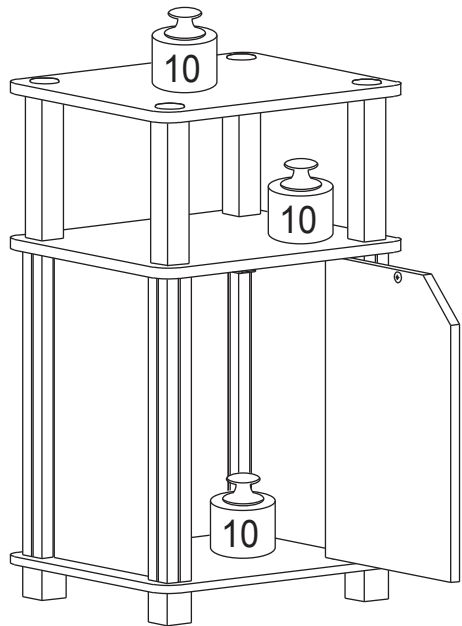

*Unit in Pound(lbs)

WARNING:

>This unit has been designed to support the maximum loads shown. Exceeding these load limits could cause sagging, instability, product collapse, and/or serious injury.

>DO NOT allow children to climb on unit.

>Put heavier items on lower shelves.

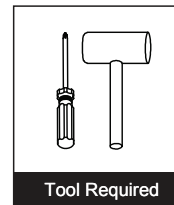





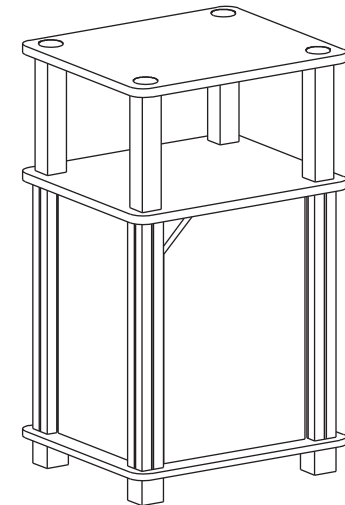

Assembly Instruction

3-Tier End Table with Door



HARDWARE AND PART LIST

NO	HARDWARE LIST	QTY	NO	PART LIST	QTY
1	SQUARE LONG POLE W/GROOVE 	4 PCS	A	TOP PANEL	1 PC
2	SQUARE SHORT POLE 	4 PCS	B	SHELF PANEL	1 PC
3	TOP CAP 	4 PCS	C	BOTTOM PANEL	1 PC
4	SQUARE LEG 	4 PCS	D	SIDE PANEL	2 PCS
5	MAGNET 	1 PC	E	BACK PANEL	1 PC
6	FLAT HEAD SCREW 	1 PC	F	DOOR PANEL	1 PC
7	DOOR SPRING 	2 PCS			

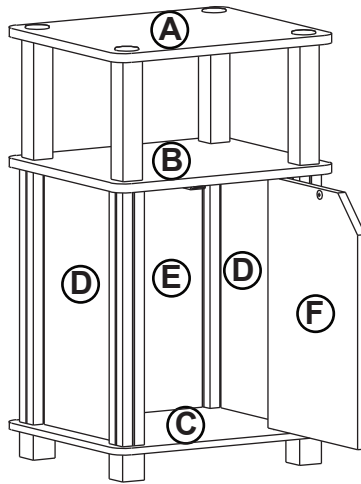

USEFUL HINTS BEFORE YOU START:

1. Read each step carefully before starting.
2. It is important that each step is performed in correct order to avoid difficulties.
3. Identify, sort and count the parts before assembly.
4. Assemble your furniture on packaging cardboard to prevent scratch or damage.
5. Clean the product with mild cleanser using soft damped cloth. Do not use harsh or abrasive cleanser.
6. Using incompatible hardware might cause damage to product.

STEP 1

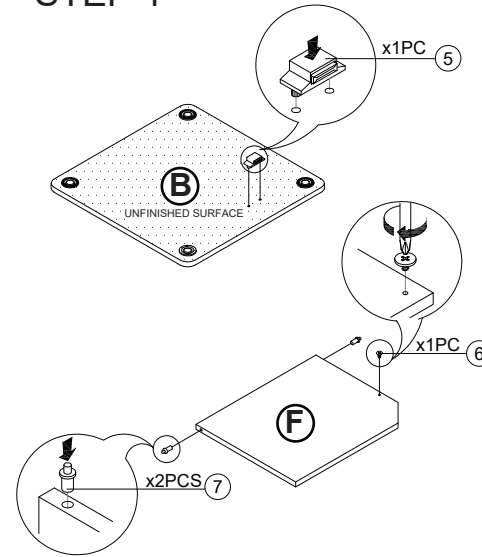

STEP 2

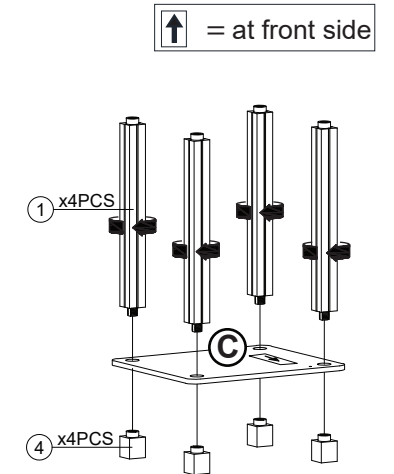

STEP 3

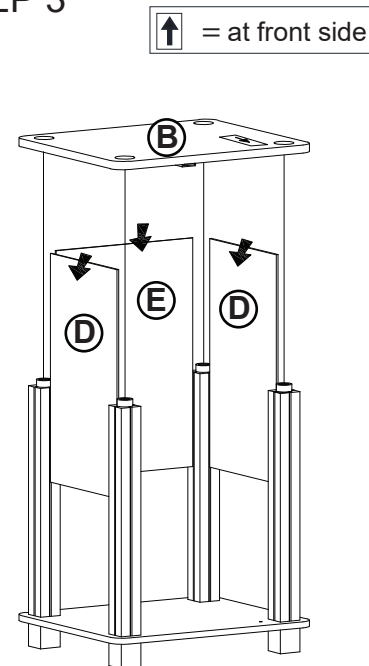

STEP 4

