

ASSEMBLY & INSTRUCTION

Size:Single(TB-S-EN)

Notice:DO NOT RETURN DIRECTLY!

If any parts are missing or damaged, we will gladly
ship replacements for free

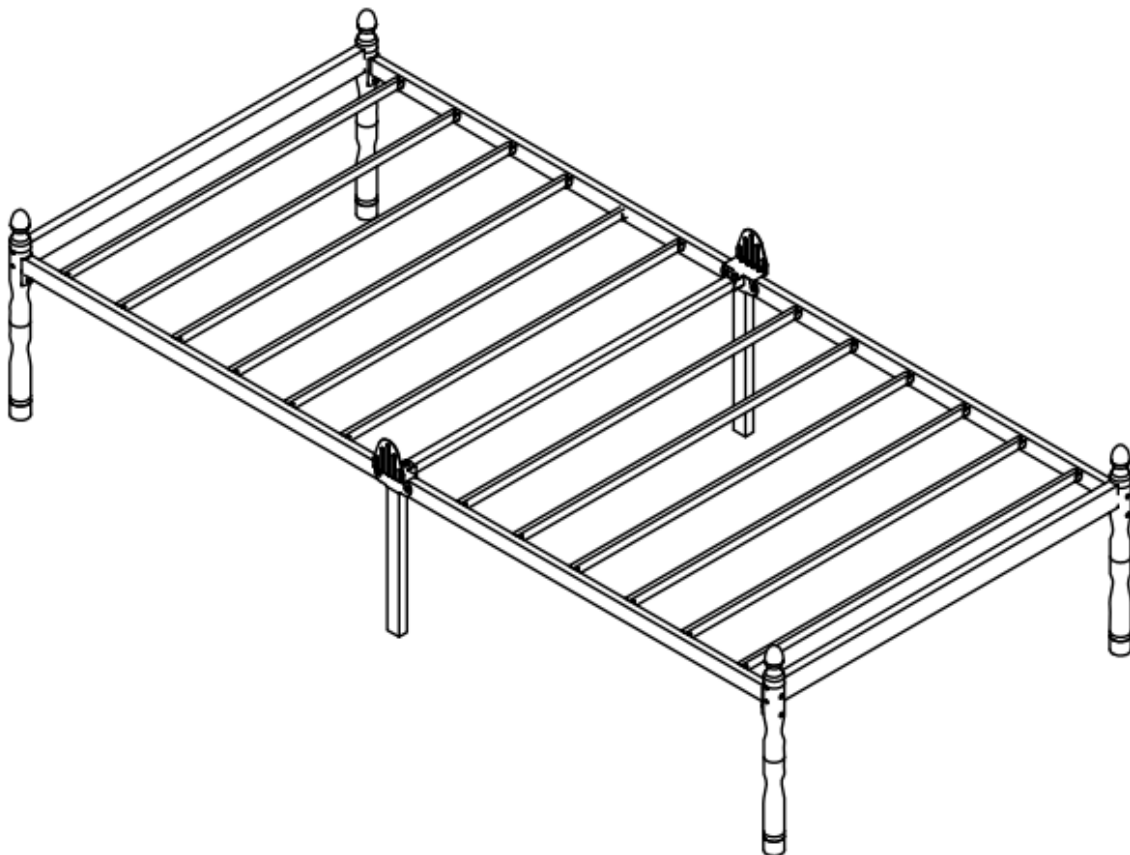

¹ Weight Limit: 1000 Lb / 450 Kg

PLEASE READ BEFORE ASSEMBLY

****Warranty Information****

1. We warrant this product to be free from defects in materials and workmanship for three years from the date of original purchase. Proof of purchase is required for all warranty claims.
2. This warranty covers the repair or replacement of defective parts only; assembly labor is not included.
3. This warranty does not apply to product that has been improperly assembled, subjected to misuse or abuse, or altered or repaired in any way. Liability for consequential damages is excluded to the extent permitted by law.

****Read Before Beginning Assembly****

1. Clear the area: Assemble in a spacious area near the product's final location, preferably on a carpet or protected surface (like the product's cardboard packaging) to safeguard both your floor and the product.
2. Recommended Assembly Team: It is recommended that at least two people assemble this product. Having an extra hand can make the process easier. Estimated assembly time is 1 hour.
3. Check for all parts: Most parts are labeled or stamped on the raw edge. Ensure all parts are included before starting.
4. Read each step carefully: Follow the assembly steps in the correct order. Skipping steps or changing the sequence can lead to difficulties.

****Caution****

1. CHOKING HAZARD - Small Parts: This product contains small parts. Keep out of reach of children.
2. DO NOT USE POWER TOOLS: Power tools can strip or damage parts and void the warranty.
3. IMPORTANT: Do not fully tighten any bolts until the entire unit is assembled. This will allow for proper alignment and adjustment during the assembly process.

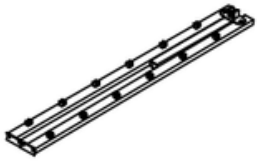

① Side Rail
2pc



④ Corner Leg
4pc

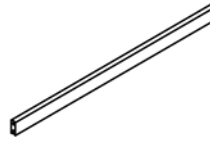

⑤ Side Bracket
2pc

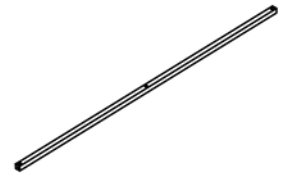

⑧ Center Support Bar
1pc

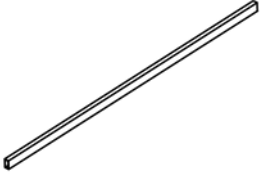

⑩ Slat
12pc



⑭ Mattress Gasket
2pc

Hardware Kit



A×3PCS
M 8×30



B×9PCS
M8×48



C×9PCS
M8×56



F×16 PCS

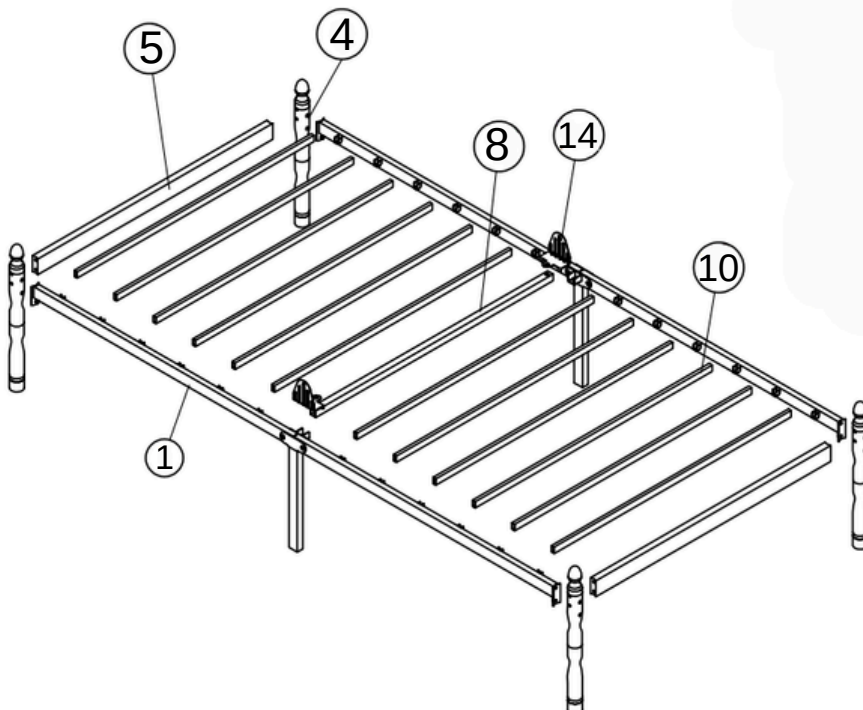

Parts

This page lists all the items included in this package. Please take a moment to identify the hardware and individual components before assembly.

Step 1

Footboard Assembly

Position the footboard rail (5) between the two footboard posts (4). Insert the bolts (C) and washers (F) through the pre-drilled holes as shown in the diagram and hand-tighten all bolts first to ensure proper alignment.

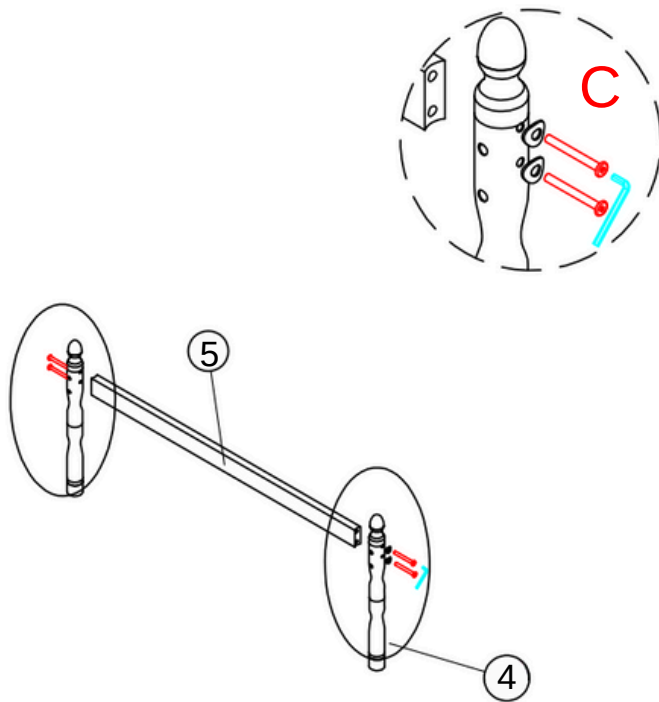

C×4 PCS
M 6* 56



F×4 PCS

Step 2

Instal the Bed Frame

Open the side rail (1) and align the mounting bracket with the appropriate holes on the corner legs. After the bolts (B) and washers (F) are in place, use the provided Allen wrench to completely tighten each bolt.

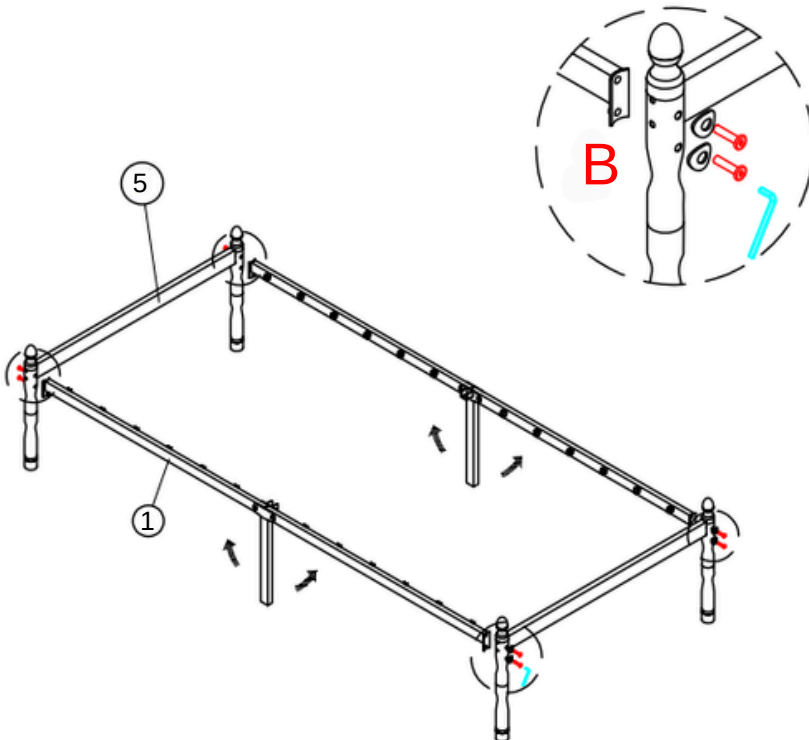

B×8PCS
M8 * 48



F×8PCS

Note: Follow the direction indicated by the red arrow in the detailed view for proper installation.

Step 3

Install center support bar

Locate center support bar and secure it with bolt A through the Mattress Gasket (14).

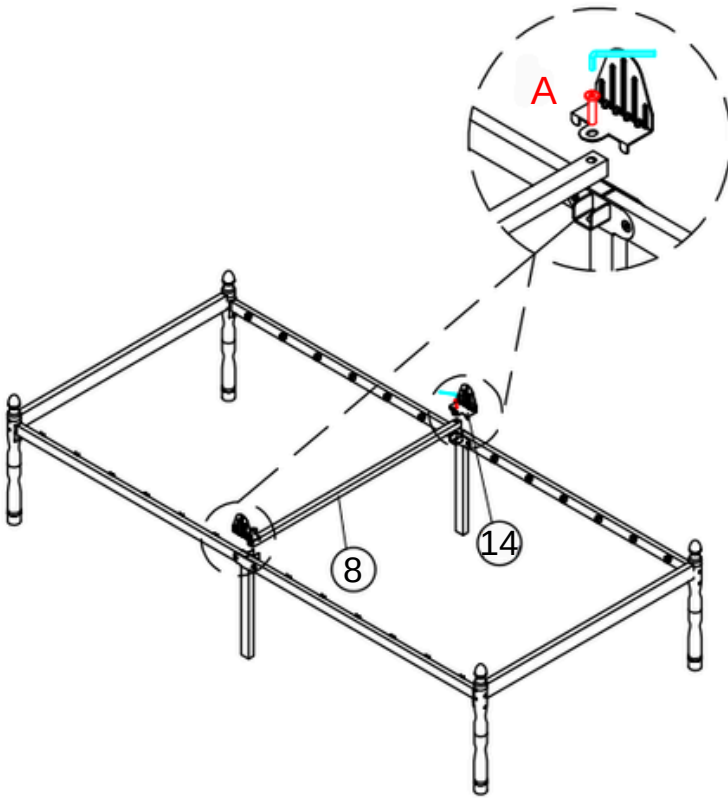

A×2PCS
M 8* 30

Note:make sure each beam is fully seated for maximum stability

Step 4

Install the Bed Slats

Place all bed slats across the side rails as shown in the diagram. Each slat should be securely positioned in the designated slots.

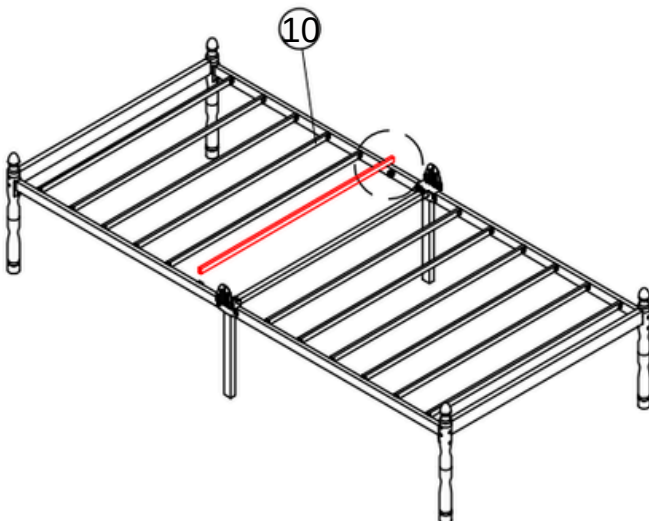
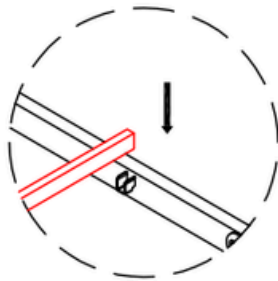

IMPORTANT INFORMATION

****REPLACEMENT PART OR HARDWARE REQUEST****

Request a replacement by logging into the marketplace account in which the purchase was made and sending a message to the seller. To expedite the request, attach applicable images relevant to the request and/or include the part number and quantity.

****Warnings****

1. Age Restriction: The bed is not designed for children under 4 years old.
2. No Jumping or Horseplay: This product is not designed to withstand jumping or rough play
3. Weight Limit: The maximum combined weight on the bed should not exceed 1000 lbs. This includes the weight of the bed itself, mattresses, bedding, and people.
4. Do not drag or push the bed frame: Always use two people to lift and reposition the bed frame to avoid damage to the frame or the floor.

****Cleaning & Care****

1. Cleaning Method: Use a dry or slightly damp soft cloth for cleaning. Avoid abrasive cleaners, which can damage the finish.
2. Hardware Maintenance: Over time, hardware can loosen. Regularly check and tighten all connections to maintain the bed's stability and prevent damage.

Please keep these instructions for future reference!