

# ASSEMBLY INSTRUCTIONS

## Chair

ASSEMBLY  
REQUIREMENTS:

2-Person  
Assembly

30 Minutes  
Assembly Time  
(Approximate)

Tools Required:  
(Not Provided)

Phillips Screwdriver  
Flat Screwdriver  
Mallet

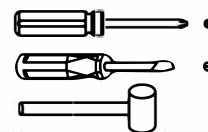

### Thank you for purchasing our product!

Please refer and use this assembly instruction to assemble the product. Contact our customer service department in case there are any missing or damage parts or hardware. Replacement parts are normally shipped within 2 or 3 days.



**PRODUCTS PURCHASED THROUGH OUR AUTHORIZED VENDORS ONLY ARE ELIGIBLE FOR REPLACEMENT PARTS.**

We appreciate your business!

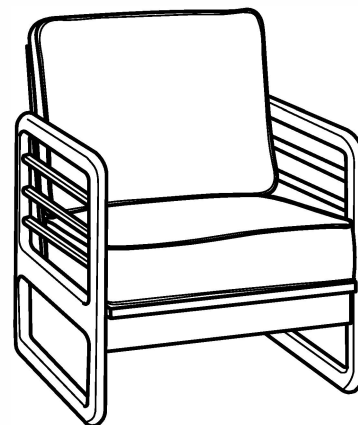

**THIS PRODUCT IS FOR INDOOR AND HOUSEHOLD USE ONLY - NOT FOR COMMERCIAL USE.**

#### ASSEMBLY PREPARATION

1. Remove all packaging materials, staples and packing straps from the carton.
2. Refer to Parts List and Hardware List and ensure parts and hardware are correct before assembly. Contact customer service for missing parts.
3. Place all wooden parts on a clean, flat and soft surface (e.g. carpet or rug) to prevent scratch and damage to parts.

#### SAFETY PRECAUTION:

1. KEEP ALL HARDWARE PARTS OUT OF REACH OF CHILDREN.
2. DISPOSE PLASTIC PACKAGING MATERIAL IMMEDIATELY TO AVOID ANY RISK OF SUFFOCATION TO CHILDREN AND ANIMALS.

#### TIPS FOR ASSEMBLY:

1. Allow ample room for assembly and in close proximity to where product will be placed.
2. Assemble the product on a surface that does not scratch or damage the exterior gloss and finish of the furniture.
3. Identify all of the parts, hardware and quantities required for each step.
4. During assembly, do not over-tighten any fittings as this may cause damage.
5. DO NOT USE POWER TOOLS TO ASSEMBLE THIS PRODUCT.
6. Always place the product on a flat, level surface.
7. Do not sit or stand on the partially assembled product; only use the product for which it is intended.

#### CARE AND MAINTENANCE

- Use a slightly damp cloth to clean the product. Do not use bleach or abrasive cleaning material.
- Check all the fittings periodically and re-tighten as necessary. Do not use the product if any of the parts is damaged or broken.
- Never allow any kind of liquid to remain on your furniture. Absorption can cause wood to warp or delaminate.
- Do not place hot items (e.g. hot drinks) directly onto the wood surface.
- Do not drag and/or pull the furniture.

# ASSEMBLY INSTRUCTIONS

## Chair





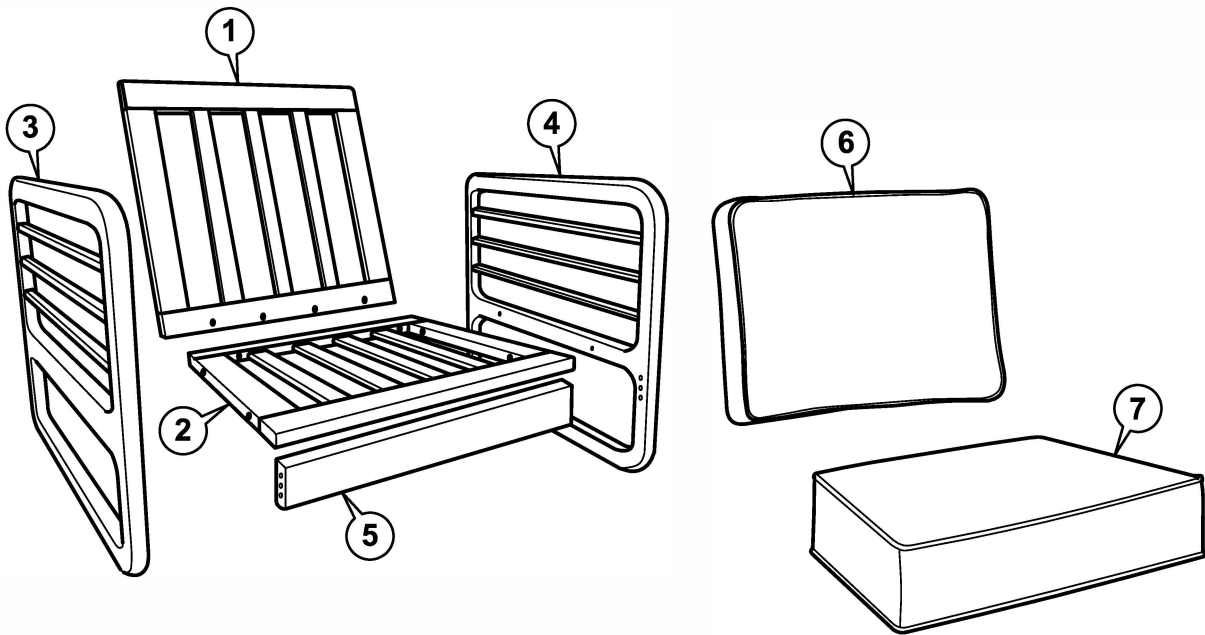

### PARTS LIST

Part#	Description	Qty
1	Chair Back	1pc
2	Chair Seat	1pc
3	Left Leg	1pc
4	Right Leg	1pc
5	Bottom Apron	1pc
6	Back Cushion	1pc
7	Cushion Seat	1pc

### PARTS ASSEMBLY OVERVIEW



### HARDWARE LIST

DESCRIPTION	QTY	EXTRA	DESCRIPTION	QTY	EXTRA	DESCRIPTION	QTY	EXTRA	DESCRIPTION	QTY	EXTRA
A  M6 x 70mm Bolt	10	2	C  1/4" Spring Washer	10	2	E  Leg Pad	4	-	G  M8 x 30mm Wood Dowel	6	-
B  M6 x 13mm Washer	8	2	D  30 x 15mm Spacer	2	2	F  M4 x 100mm Allen Key	1	-			

\* Extra hardware for spare use

# ASSEMBLY INSTRUCTIONS

## Chair

### STEP 1

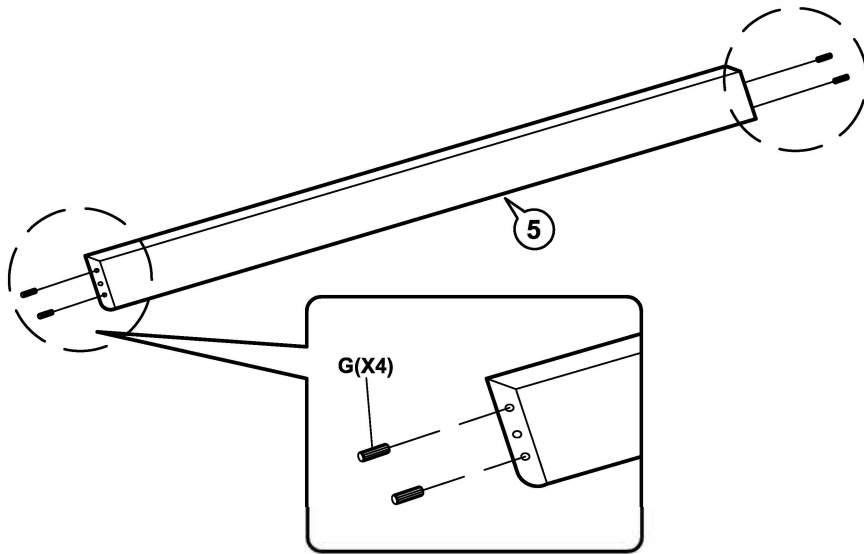

Insert Wood Dowel (G) into the top and bottom holes on each end of Bottom Apron (5) as shown. Use a mallet to tightly tap wood dowel into the hole as needed.

### STEP 2

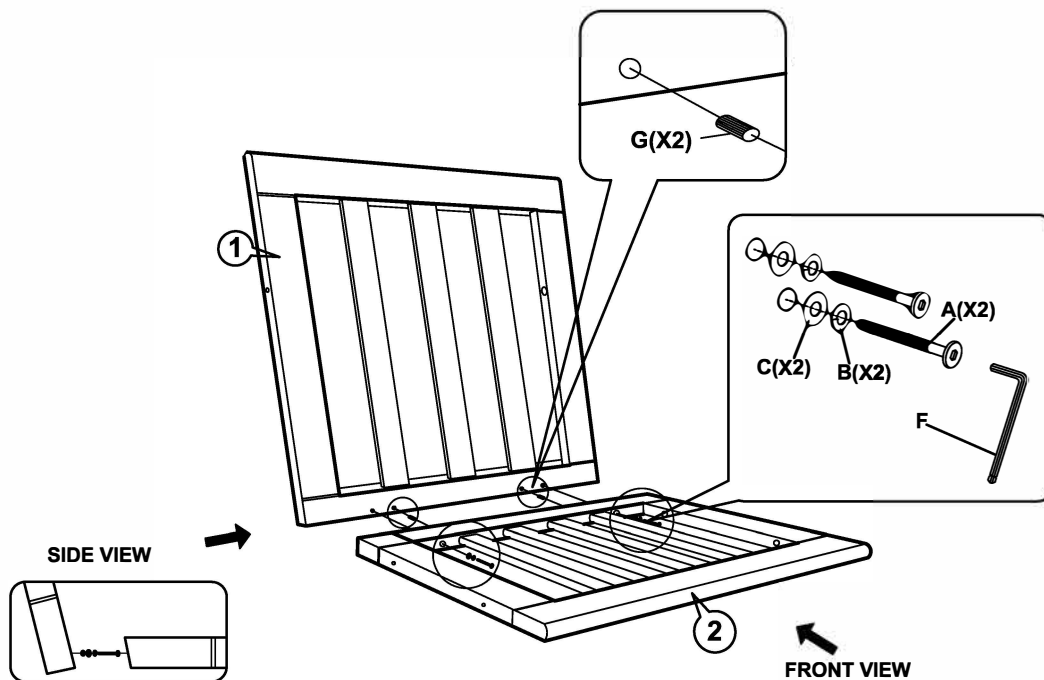

- On a flat surface, place Chair Back (1) and Chair Seat (2) as shown on a soft material to prevent scratch and damage.
- Insert Wood Dowel (G) into the 2 inner holes near the base edge of (1) and attach (2).
- Insert Bolt (A) fitted with Spring Washer (B) and Flat Washer (C) through the designated hole on (2) to fasten (1) to (2). Use Allen Key (F) to drive and tighten (A) completely.

# ASSEMBLY INSTRUCTIONS

## Chair

### STEP 3

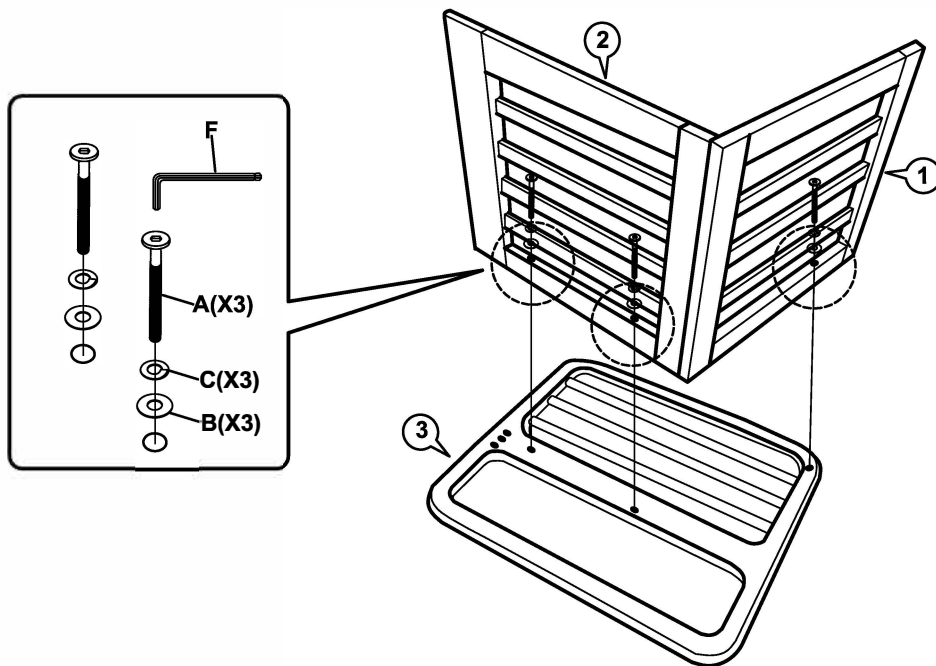

- On a flat surface, place Left Leg (3) on a soft material to prevent scratch and damage.
- Position the assembly from STEP 2 to align the bolt holes on Chair Back (1) and Chair Seat (2) to (3) and insert Bolt (A) fitted with Spring Washer (C) and Flat Washer (B) to fasten (1) and (2) to (3). Use Allen Key (F) to drive and tighten (A). DO NOT OVER-TIGHTEN.

### STEP 4

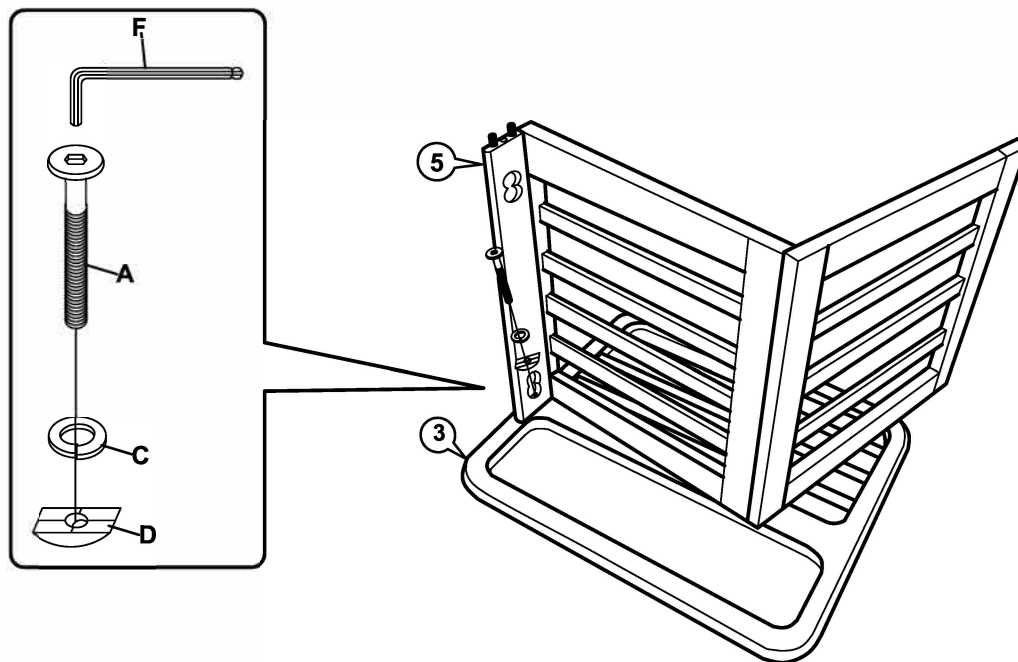

- Position Bottom Apron (5) from STEP 1 to align the bolt holes on (5) to Left Leg (3) and insert Bolt (A) fitted with Spring Washer (C) and Spacer (D) to fasten (5) to (3). Use Allen Key (F) to drive and tighten (A) completely. DO NOT OVER-TIGHTEN.

# ASSEMBLY INSTRUCTIONS

## Chair

### STEP 5

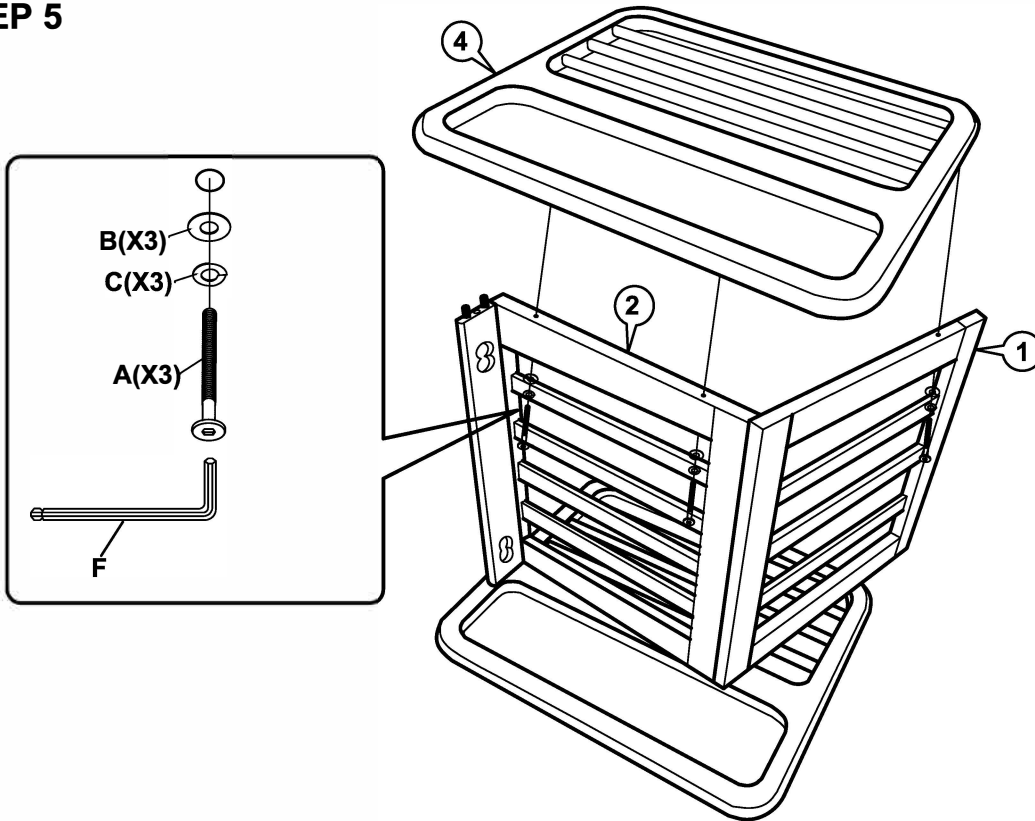

- Attach Right Leg (4) to Bottom Apron (5) and align the bolt holes on (4) to Chair Back (1) and Chair Seat (2) to (4).
- Insert Bolt (A) fitted with Spring Washer (C) and Flat Washer (B) to fasten (1) and (2) to (4). Use Allen key (F) to drive and tighten (A). Do not tighten (A) completely until all 3 bolts are in place. **DO NOT OVER-TIGHTEN.**

### STEP 6

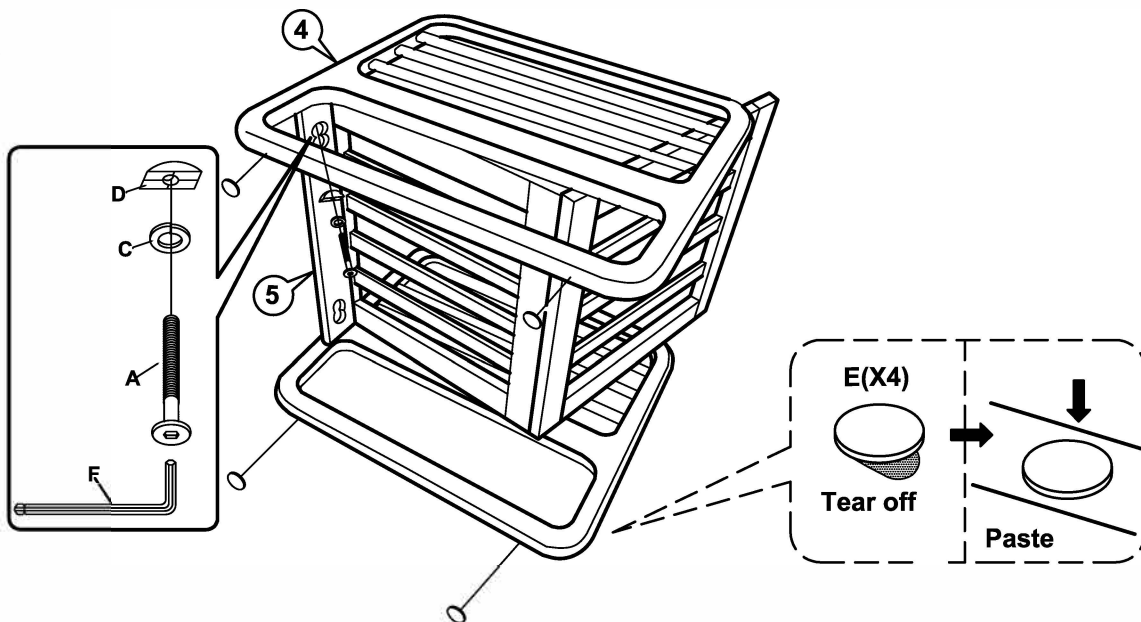

- Insert Bolt (A) fitted with Spring Washer (C) and Spacer (D) to fasten (5) to (4). Use Allen Key (F) to drive and tighten (A) completely. **DO NOT OVER-TIGHTEN.**
- Affix Leg Pad (E) to the bottom of Left and Right Leg as indicated.

# ASSEMBLY INSTRUCTIONS

## Chair

### STEP 7

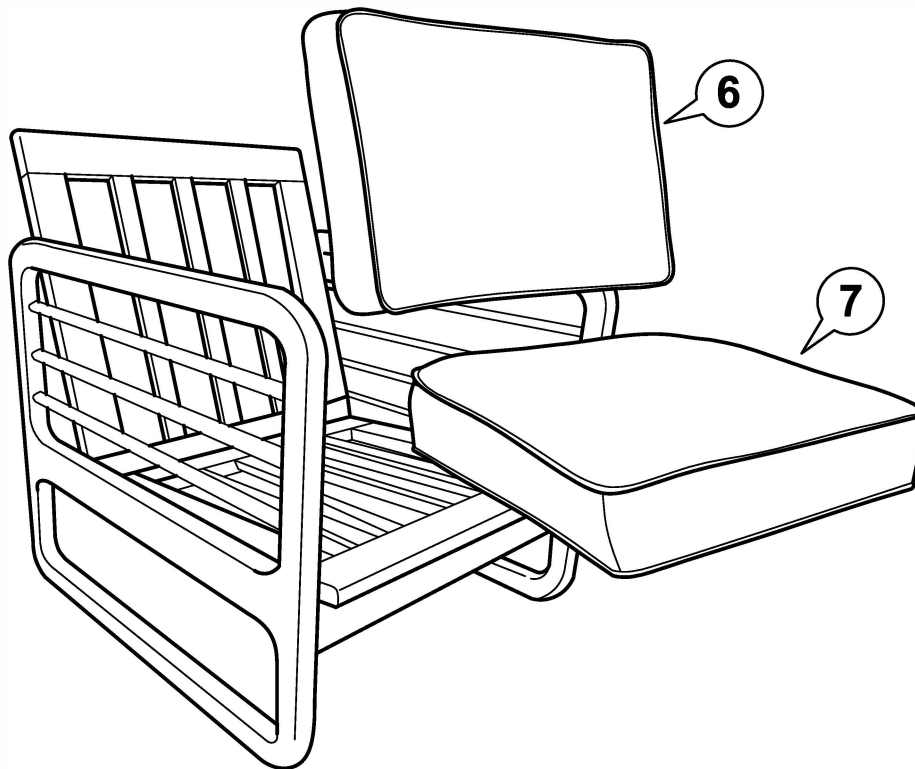

Put in Cushion Seat (7) and Back Cushion (6).  
The assembly of the Divani Chair is complete.