

ASSEMBLY INSTRUCTIONS

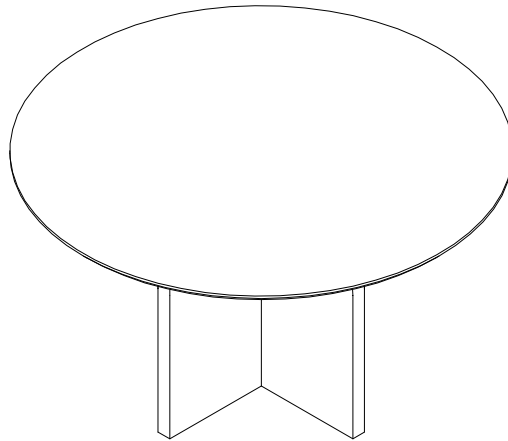

STEP 1

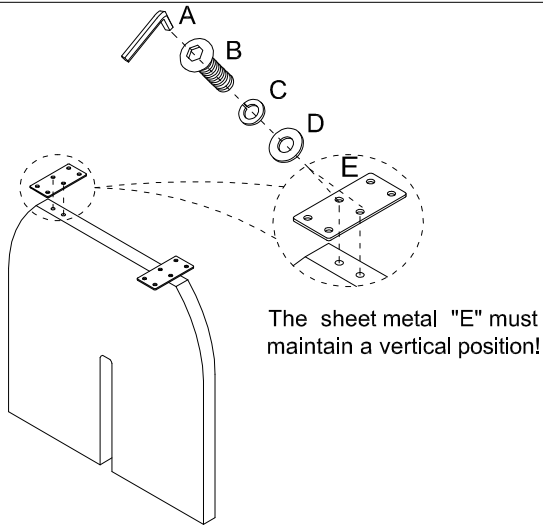

STEP 2

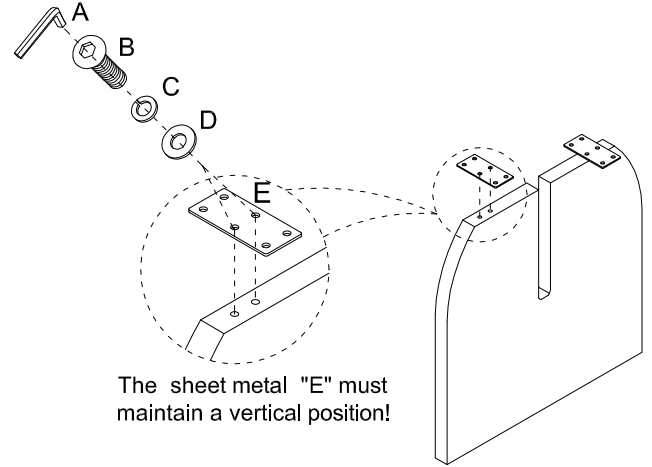

STEP 3

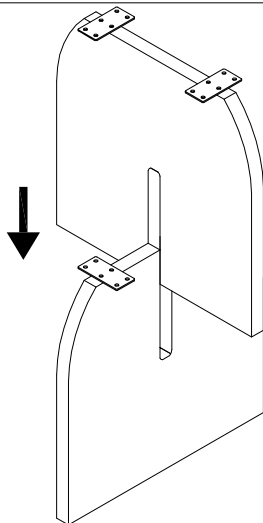

STEP 4

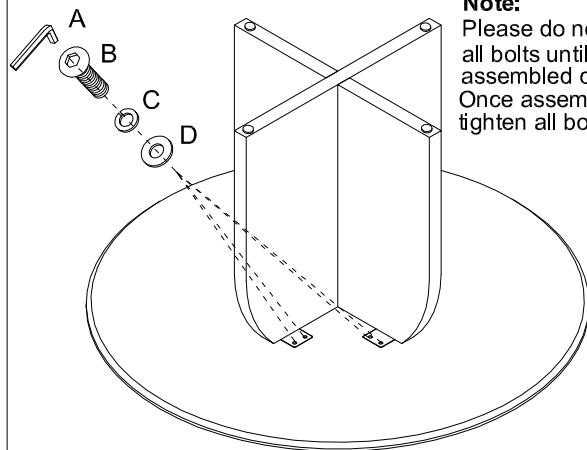

PARTS LIST

	Top Panel	1PC
	Leg	1PC
	Leg	1PC

HARDWARE LIST

A		1PC	5/16"
B		24PCS	5/16" *3/4"
C		24PCS	5/16"
D		24PCS	5/16"*19MM
E		4PCS	148*68*3MM

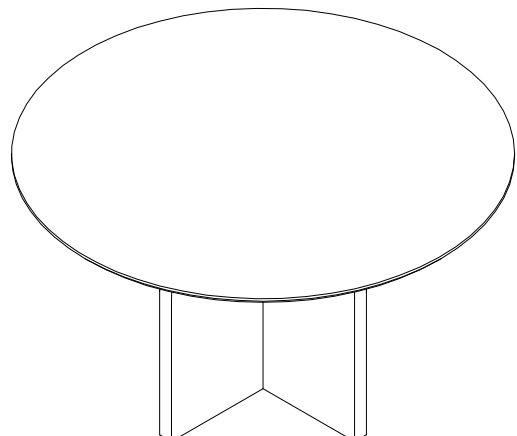

OK