

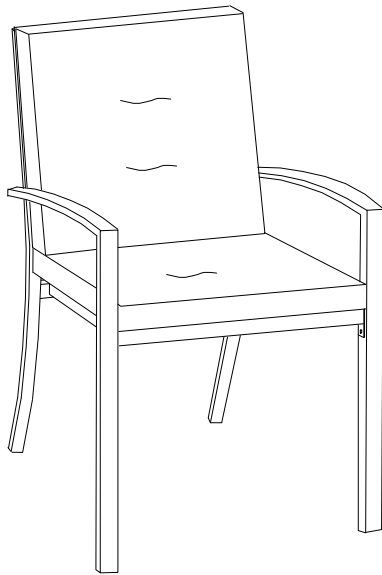







Outdoor Dining Chair

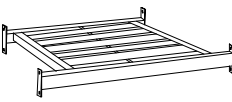
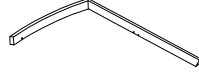
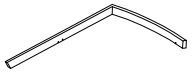

PART LIST

A 	B 	C 	D 	E 
Back Panel 2 PCS	Seat Panel 2 PCS	Right Arm Panel 2 PCS	Left Arm Panel 2 PCS	Seat Cushion Cover * 2 PCS
F 	G 	H 	*Please note cushion covers will ship separately.	
Seat Cushion Core 2 PCS	Back Cushion Cover * 2 PCS	Back Cushion Core 2 PCS		

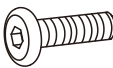
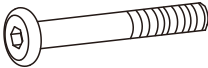
HARDWARE LIST

#1 	#2 	#3 	#4 
M6*12mm Short Bolt 16 PCS (Extra 2)	M6*45mm Long Bolt 4 PCS (Extra 1)	M6mm Flat Washer 20 PCS (Extra 2)	M6mm Allen Wrench 1 PC

Step 1. Lay left arm panel (part D) down on a soft flat surface, such as carpet, as shown below. Attach seat panel (part B) to left arm panel (part D) using short bolts (part #1), flat washers (part #3) and allen wrench (part #4).

NOTE: Please do not fully tighten bolts until unit is fully assembled.

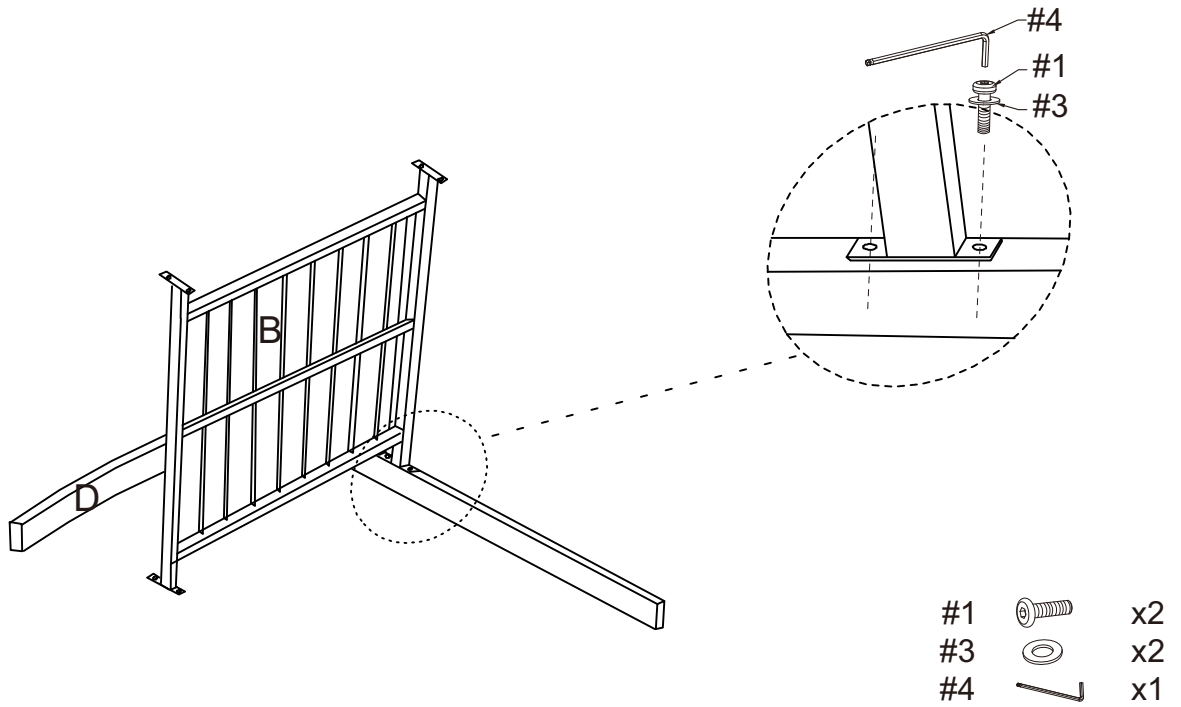

Step 2. Attach right arm panel (part C) to seat panel (part B) using short bolts (part #1), flat washers (part #3) and allen wrench (part #4).

NOTE: Please do not fully tighten bolts until unit is fully assembled.

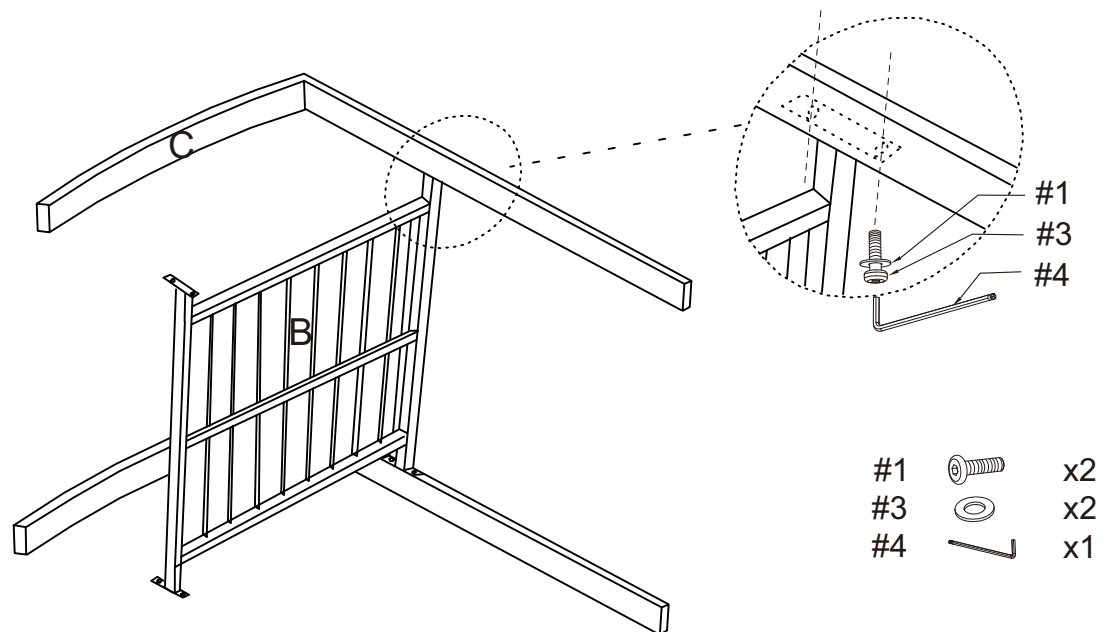

Step 3. Attach back panel (part A) to assembled unit (parts B,C & D) using shorts bolts (part #1), long bolts (part #2), flat washers (part #3) and allen wrench (part #4).

NOTE: Please fully tighten all bolts at this time.

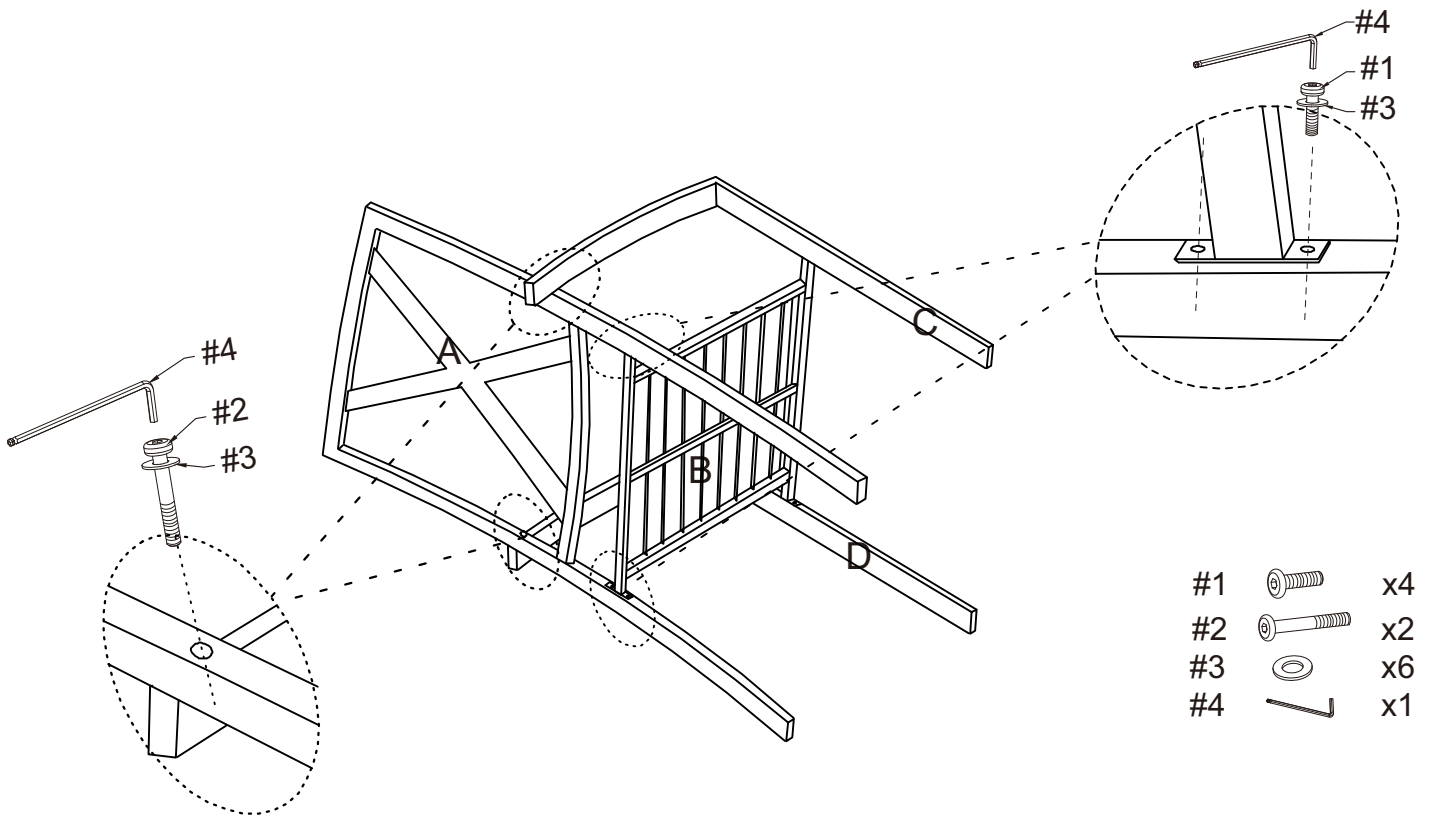

Step 4. Insert seat cushion core (part F) into seat cushion cover (part E).
Insert back cushion core (part H) into back cushion cover (part G).

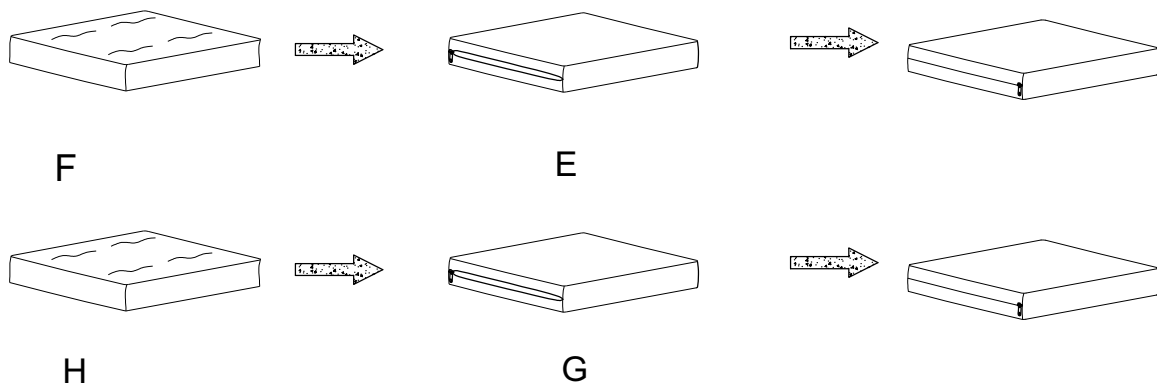

Step 5. Carefully turn unit upright. Place seat cushion and back cushion as shown below. Repeat steps 1-5 to assemble remaining chair.

