

Tube Steel Bench

Assembly Instructions

Assembly Tips:

This product assembles in 5 minutes with 2 people, but can be assembled solo.

To properly align this product, all bolts should be first be fastened to a point of being barely snug. DO NOT "tighten as you go."

When all eight bolts are in, place some weight on the seat of the bench and tighten, working opposite corners.

If the assembled unit does not sit solid on all 4 corners, repeat the last step.

Parts List

A Bench back	1
B Bench seat	1
C Side frames	2

Hardware*

2 1/2" Bolts	4
1 1/2" Bolts	4
"L" wrench tool	1

No other tools needed

* We provide one extra bolt of each size.

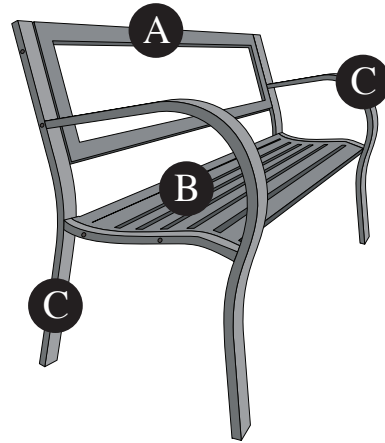

1. Stand the seat on end and place the appropriate side frame on top, lining up the holes in the side frame with the threaded inserts in the end of the seat section. Insert the 1 1/2" (short) bolts and screw them into the inserts until they are just about snug. Leave a small amount of play. Repeat on the other side.

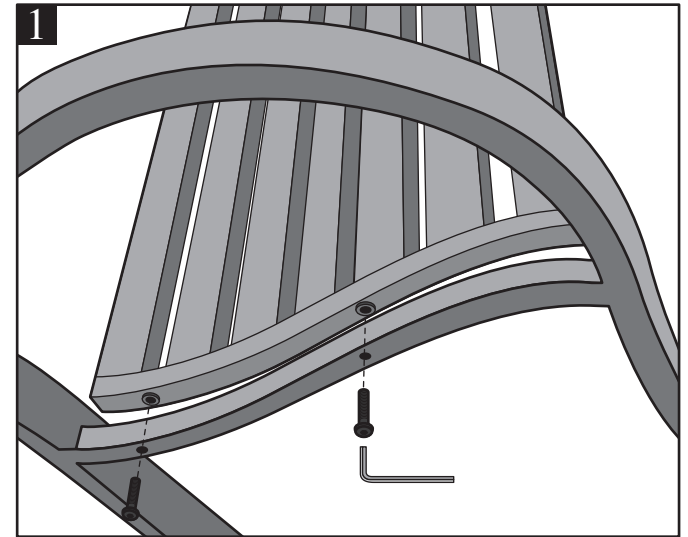

2. Stand the unit on its legs and position the backrest between the upper part of the side frames. (If it is difficult to fit the backrest between the side frames, loosen the seat bolts a turn or two.) Insert the 2 1/2" (long) bolts from the outside and screw into the threaded inserts in the side of the backrest frame. When everything is attached, make sure connections are straight and secure, then tighten all 8 bolts.

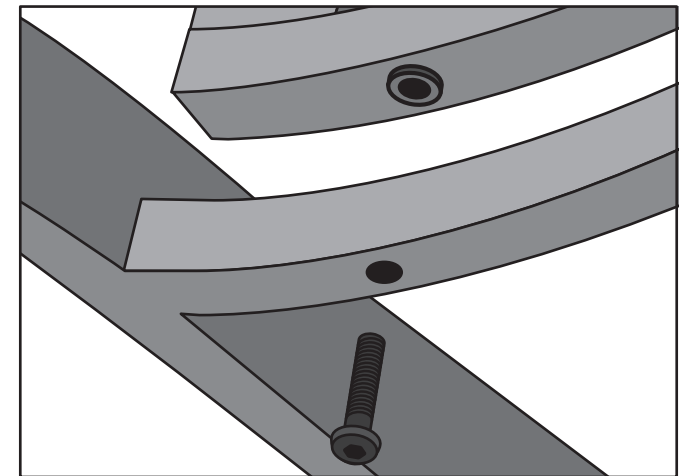
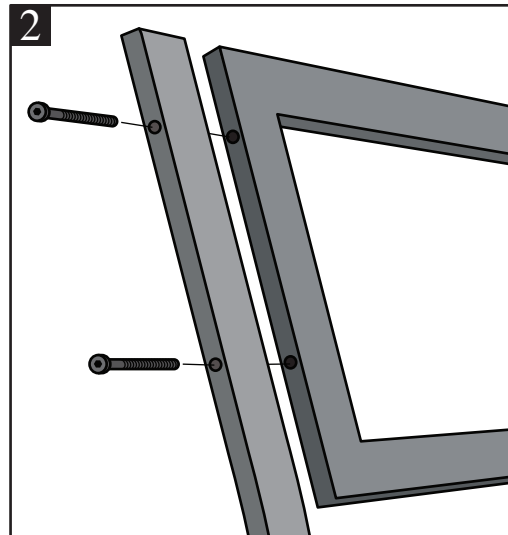

(Note: The curved bar on the side frame that attaches to the seat is offset. This must go to the OUTSIDE on both ends. If you have the right and left switched around, the backrest will appear to be too narrow.

Maintenance Tip:

Although this is a maintenance-free product, there are steps you can take to keep it looking its best. Sun exposure will eventually break down any paint, even 2 layers of powder coat. Less sun exposure equals longer paint life. Partial shade placement, off season storage, etc. helps extend the life of the finish. If the product needs to be in the sun year-round, do so. That's what it was designed for.