

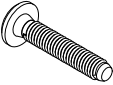

ASSEMBLY INSTRUCTIONS

3600013

HARDWARE

A x 12	B x 12	C x 12	D x 1
			
M6 X 35 mm	Ø11 X 1.5 mm	Ø12.5 X 1 mm	

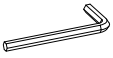
PARTS

[1] x 1

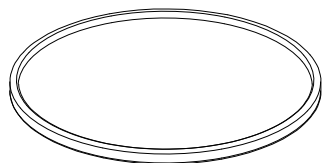

[2] x 4

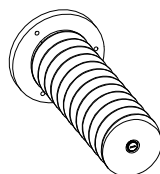

(1)  CAUTION : Due to the weight of this item, two people are recommended for safe lifting and assembly.

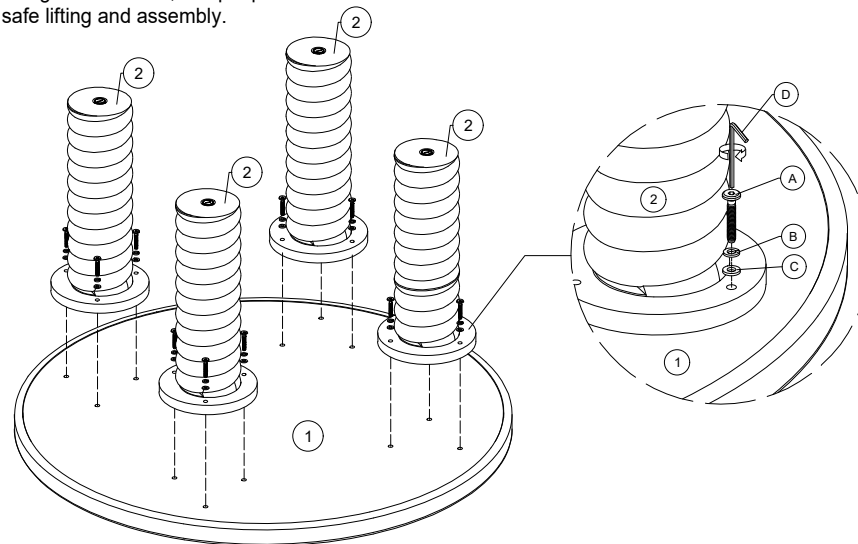

Assemble on a clean non-marring surface (such as the product's packing foam)

- Place the Top Panel (1) on the floor. Attach four legs (2) to the Top Panel (1) using Bolt (A), Lock Washer (B), and Flat Washer (C). Secure each leg with the Allen Key (D).

(2)

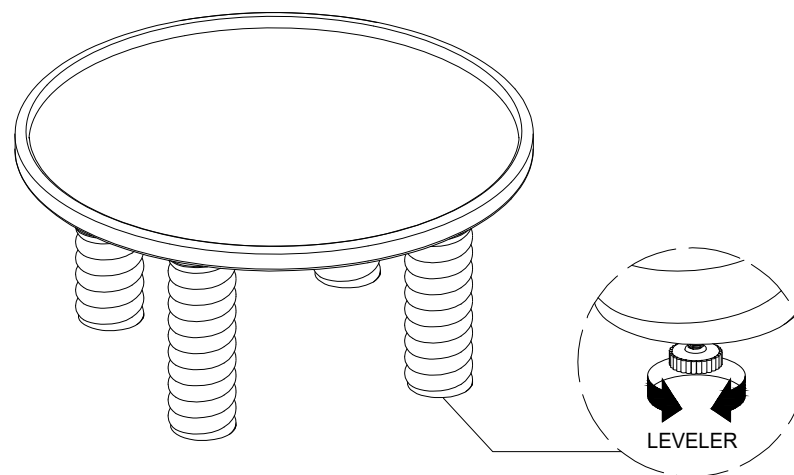

- Stand the CoffeeTable upright, then adjust the levelers located at the bottom of each Leg (2). Turn them outward, counterclockwise, to help compensate for uneven surfaces.