

Floor Mounted Tub Filler Faucet

inch(mm)

3083700

You may need



For easy installation of your faucet you will need:

To READ ALL the instructions completely before beginning.

To READ ALL warnings, care, and maintenance information.

Cleaning and Care

Care should be given to the cleaning of this product. Although its finish is extremely durable, it can be damaged by harsh abrasives or polish.

To clean, simply wipe gently with a damp cloth and blot dry with a soft towel.

With 1.8 gpm are compliant with California water efficiency regulations, Complies with California Proposition 65 and with the Federal Safe Drinking Water Act.

Water Use Information:

1.8 gpm 6.8L/min,
You can choose to replace the current limiting device and face the water pipe square.

Attach hand shower to hose, with gasket between connection.

The 1.8gpm gasket - with o-ring side should face to the hose.

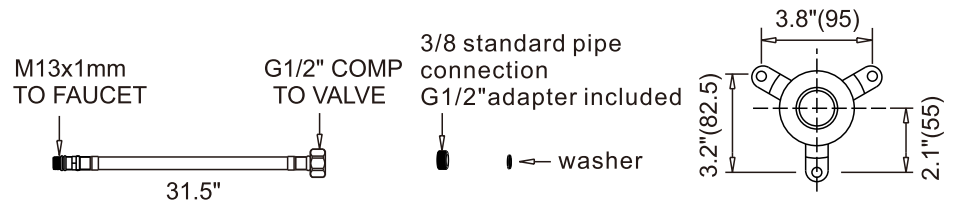
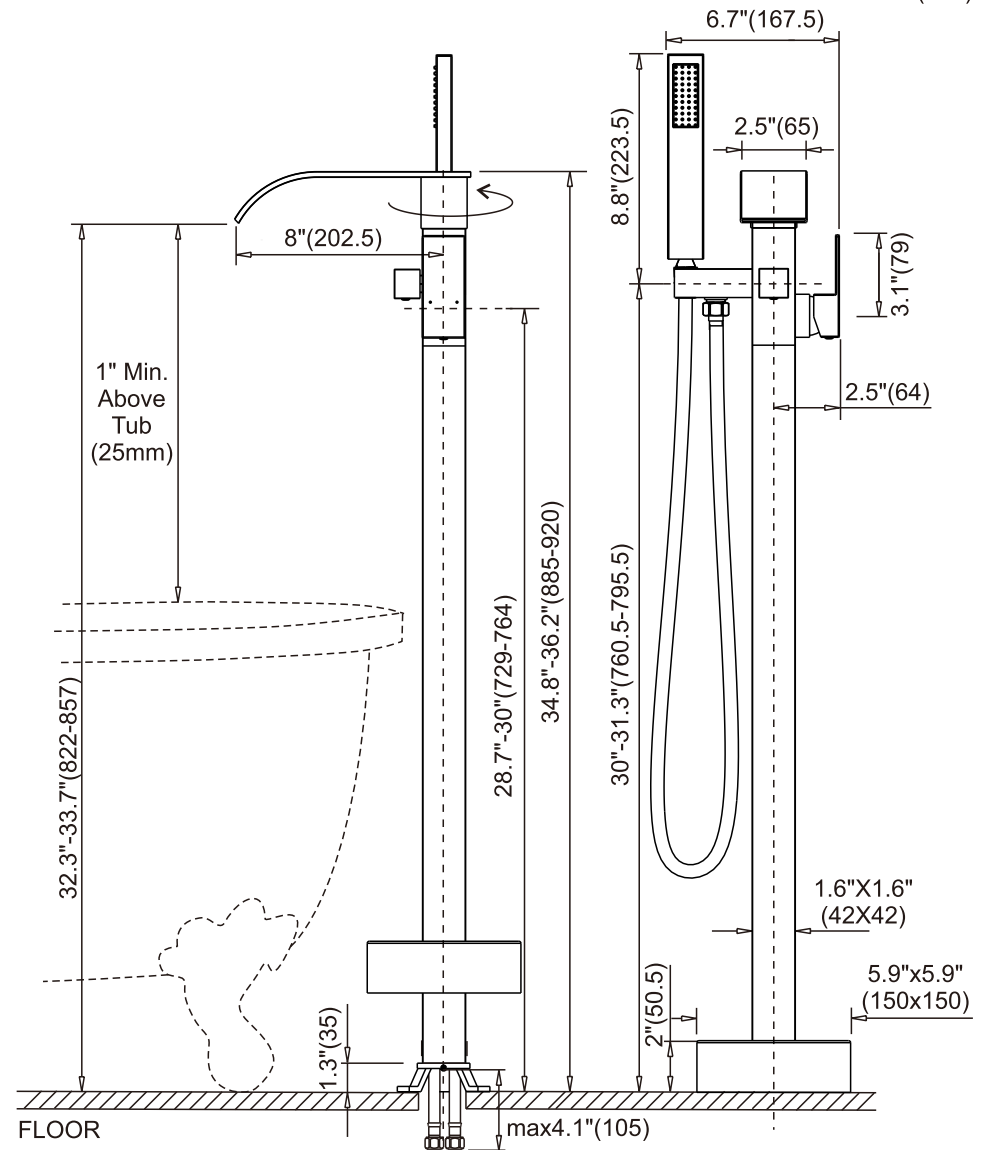
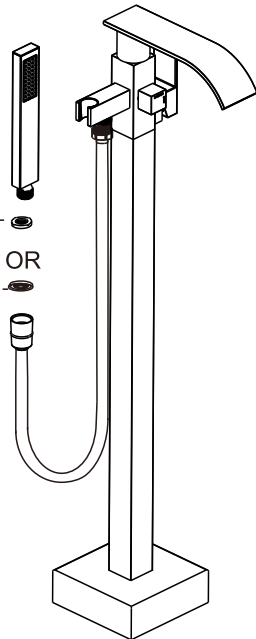

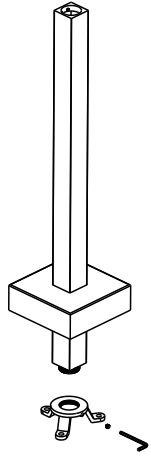

1. Place the flange over the standpipe and push it to the base.
 2. Connect the brass base seat to the standpipe, fasten the base seat and standpipe with an allen key.

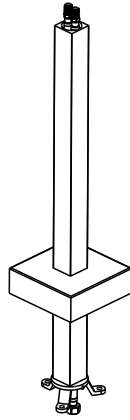

Place the water inlet supply hoses to the standpipe

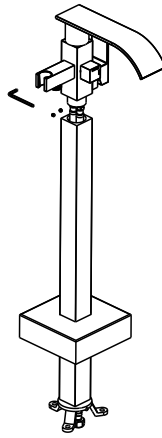

Tune the inlet supplies to mixer, verify the hot one with red line and the cold one with the blue line. Attach the mixer to the standpipe. Tighten the hot and cold inlet hoses to mixer, fasten the mixer with standpipe with screws.

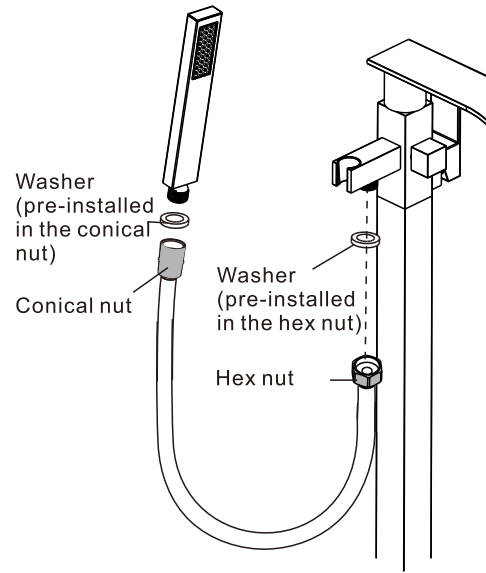

1. Screw hex nut with Hose Washer in place onto the mixer. Hand tighten connection.
 2. Screw Conical nut with Hose Washer in place onto handheld shower. Hand tighten connection.

SHOWER

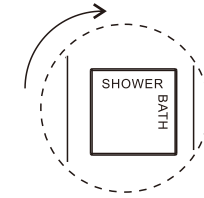

gasket (pre-installed in the conical nut)

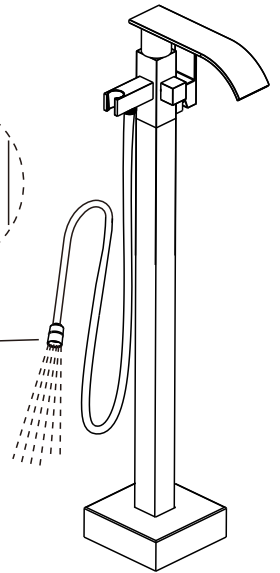

Twist here to switch ON to shower
 Pull hose to its furthest extension and hold it down into the tub.
 Turn on hot and cold water supplies and flush water lines for one minute.

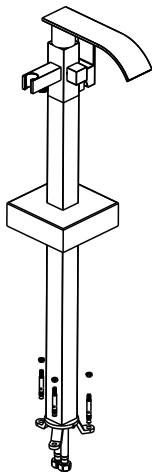

Mark the locations for the screws with a pencil. With an electric drill, drill 3 holes for the expansion screws in the floor. Place the expansion screw into the holes. Connect the flexible supply lines to the water supplies.

Ensure the standpipe sits flush against the finished floor surface. Then secure the standpipe using screws. Push the escutcheon over the standpipe base so that it sits flush against the finished floor surface.

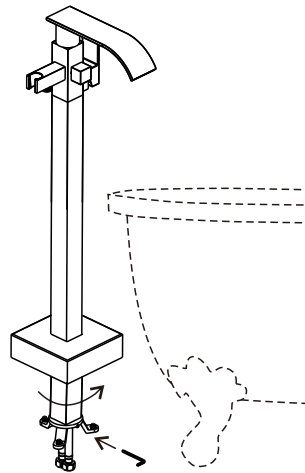

When the position of the faucet is not coordinated with the bathtub, you can use a hex key to loosen the screw, rotate the standpipe counterclockwise, adjust the appropriate position, and then reassemble the screw.

BATH

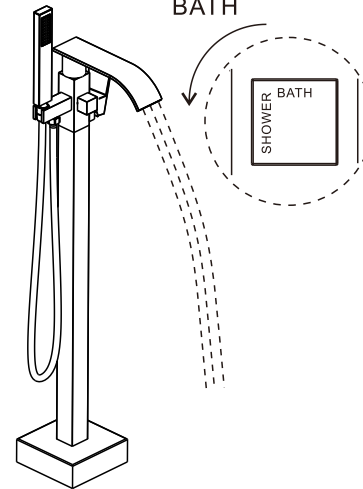

Turn faucet handles all the way on. Twist here to switch ON to BATH
 Turn on hot and cold water supplies and flush water lines for one minute. Important: This flushes away any debris that could cause damage to internal parts.

BATH

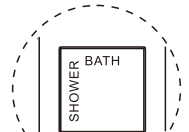

OFF

Twist here to switch ON to BATH.
 Turn off the faucet handles.

FLUSH SYSTEM/CHECK FOR LEAKS. Turn on hot and cold water supplies and flush water lines for one minute. Check all connections at arrows for leaks. Retighten if necessary, but do not overtighten.