

Instruction Book

For specification:

90cm(L)x40cm(W)x140cm(H)

Instruction manual

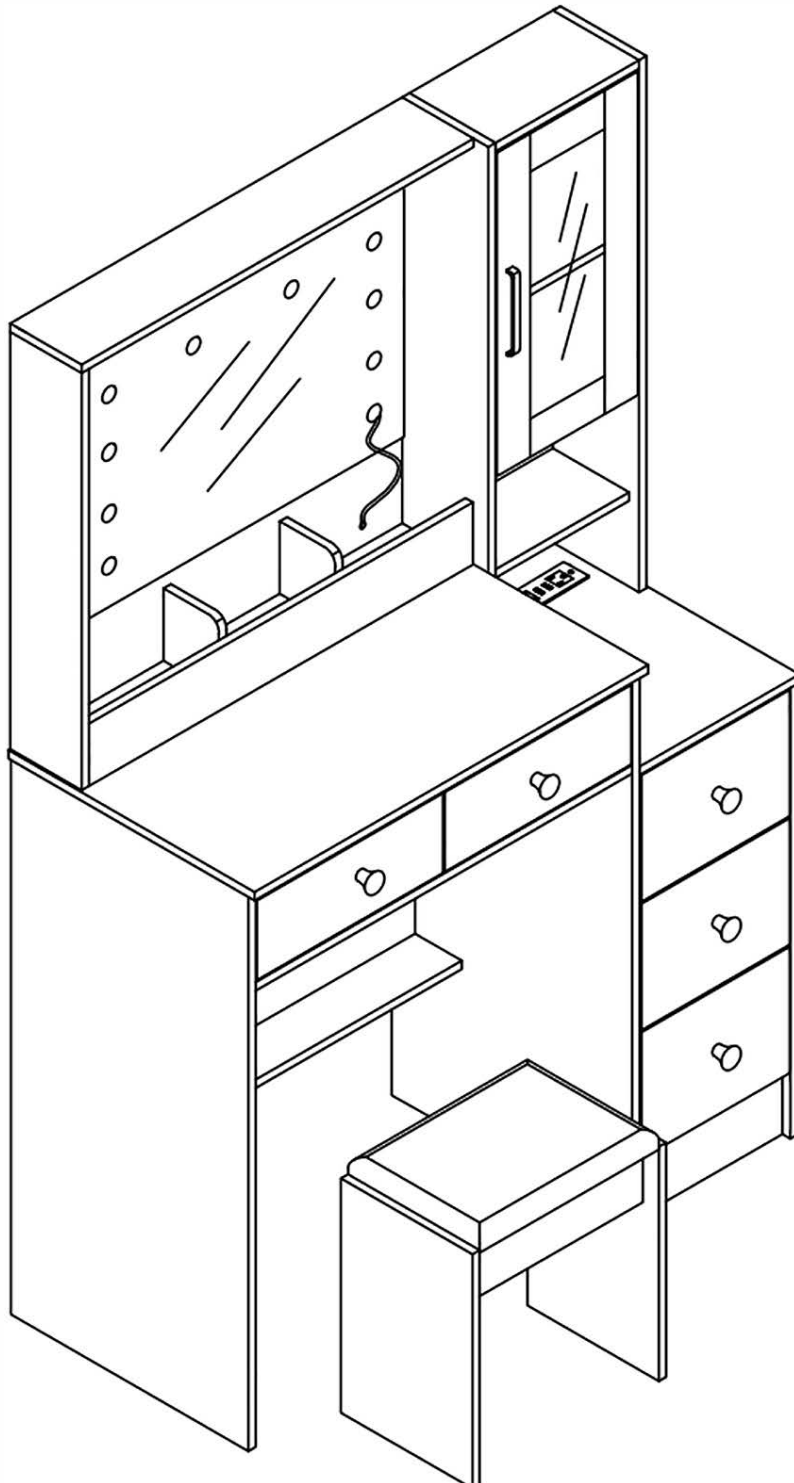

Please don't tighten the screws completely and go back later for a final tightening of all the screws after pieces are aligned with each other. If you have any question, please feel free to contact us.

Foreword:

Thank you for choosing our product! We hope you have a good shopping experience!

We aim to provide a 100% satisfaction product and customer service. If the received product has missing parts or components, arrived damaged, dissatisfaction with the order, or has questions about the assemble, please do not hesitate to contact us. Our customer service will reply within 12 hours.

Specifications:

Product name: Makeup Vanity Desk with Lights and Mirror

Package Dimension: 35 x26 x7.9 in / 89*66*20 cm

Product Size: 35.4x15.7x55.1 in /90x40x140 cm







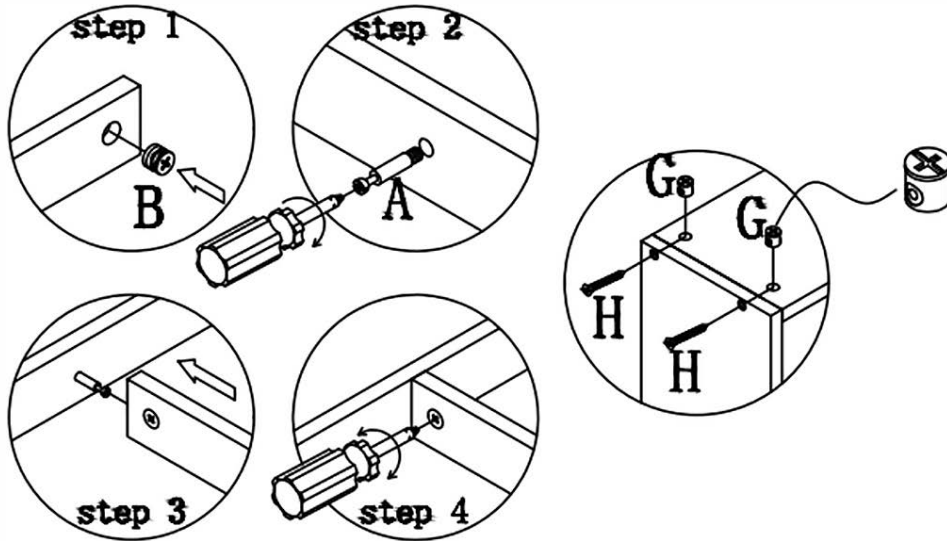













Weight: 81.68lb/37KGS

Left cabinet

A, B, G, H, C, D installation guide







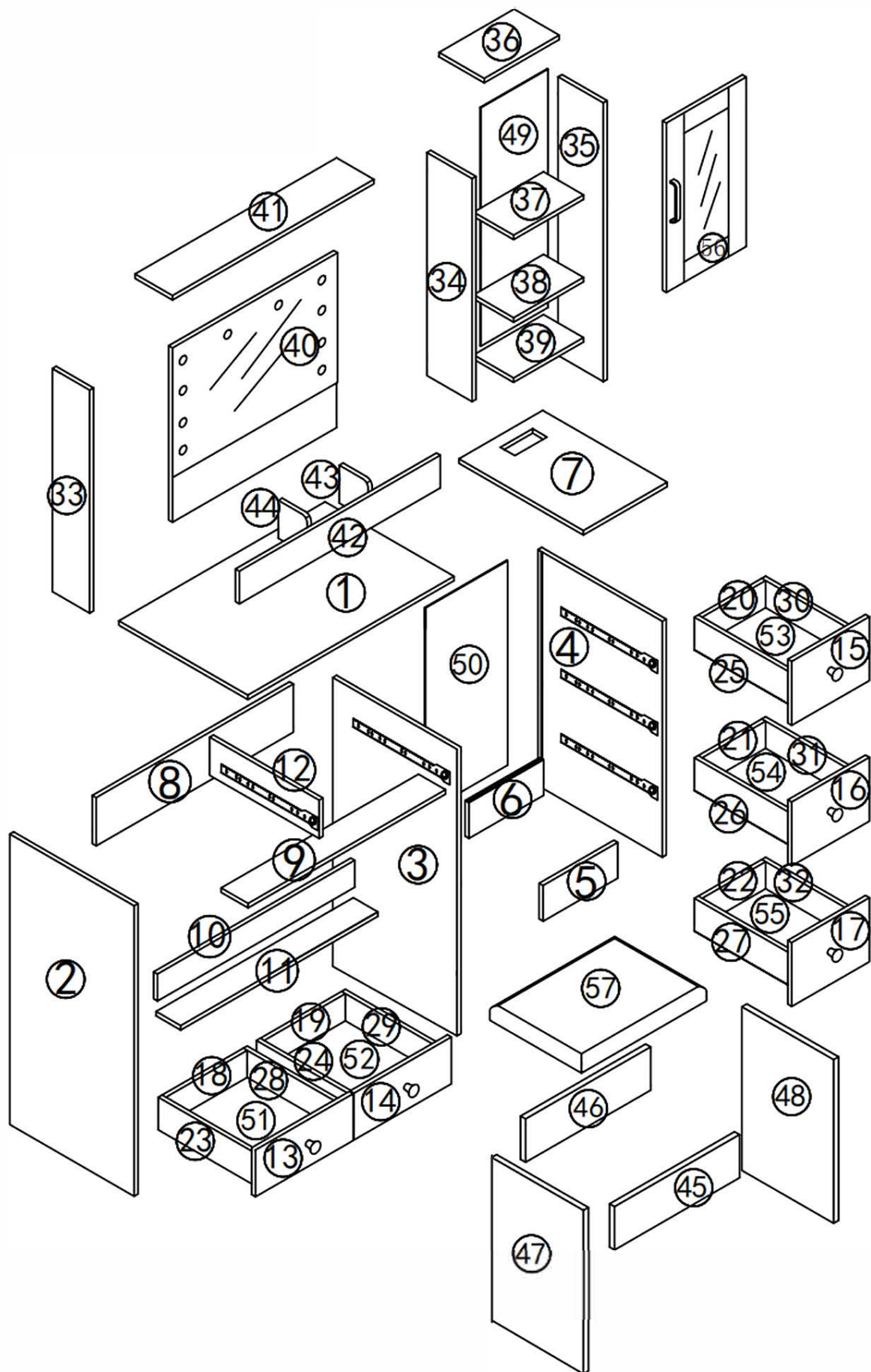

Accessories

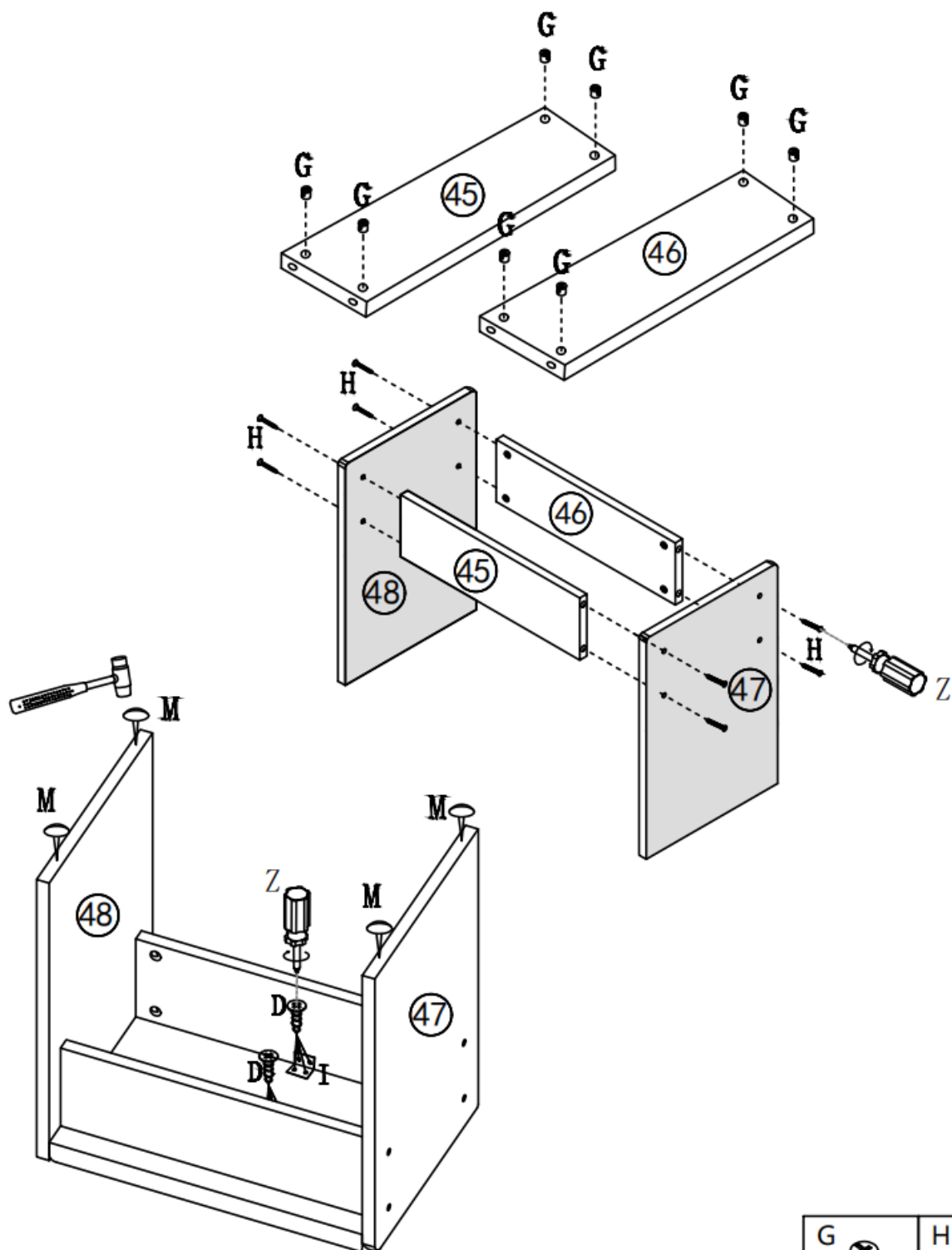
 Three-in-one screw A*86	 Three-in-one nut B*86	 drawer Track CR*5	 drawer Track DR*5	 drawer Track CL*5	 drawer Track DL*5
 Small Screw D*72	 Handle E*1	 Handle Screw F*5	 Handle Screw F2*2	 Two-in-one screw H*10	 Two-in-one nut G*10
 Corner code I*2	 Small Screw X*25	 Steel foot nail M*12	 usb power Q*1	 Bulb K*1	 Door hinges O*2
 Handle E2*5	 screwdriver Z*1				



STEP 1



G	 x8	H	 x8
M	 x4	I	 x2
		D	 x8

Guidelines for the use of 3-in-1 connecting rods:

The blue screw cap at the bottom of the 3-in-1 connecting rod is twist-able, and it can be twisted clockwise or counterclockwise to fit the size of the reserved holes in the wooden board.

When you use this 3-in-1 connecting rod, if you find that it can't be inserted into the reserved holes on the wooden board, just loosen the blue screw cap a bit until it fits into the holes of the board. Then use a screwdriver to tighten the screws. Note: If the bottom blue screw cap is not stretched apart by the three-in-one connecting rod in the reserved hole, the connected part will appear unstable .

STEP 2

Put it into the reserved holes and tighten the screw

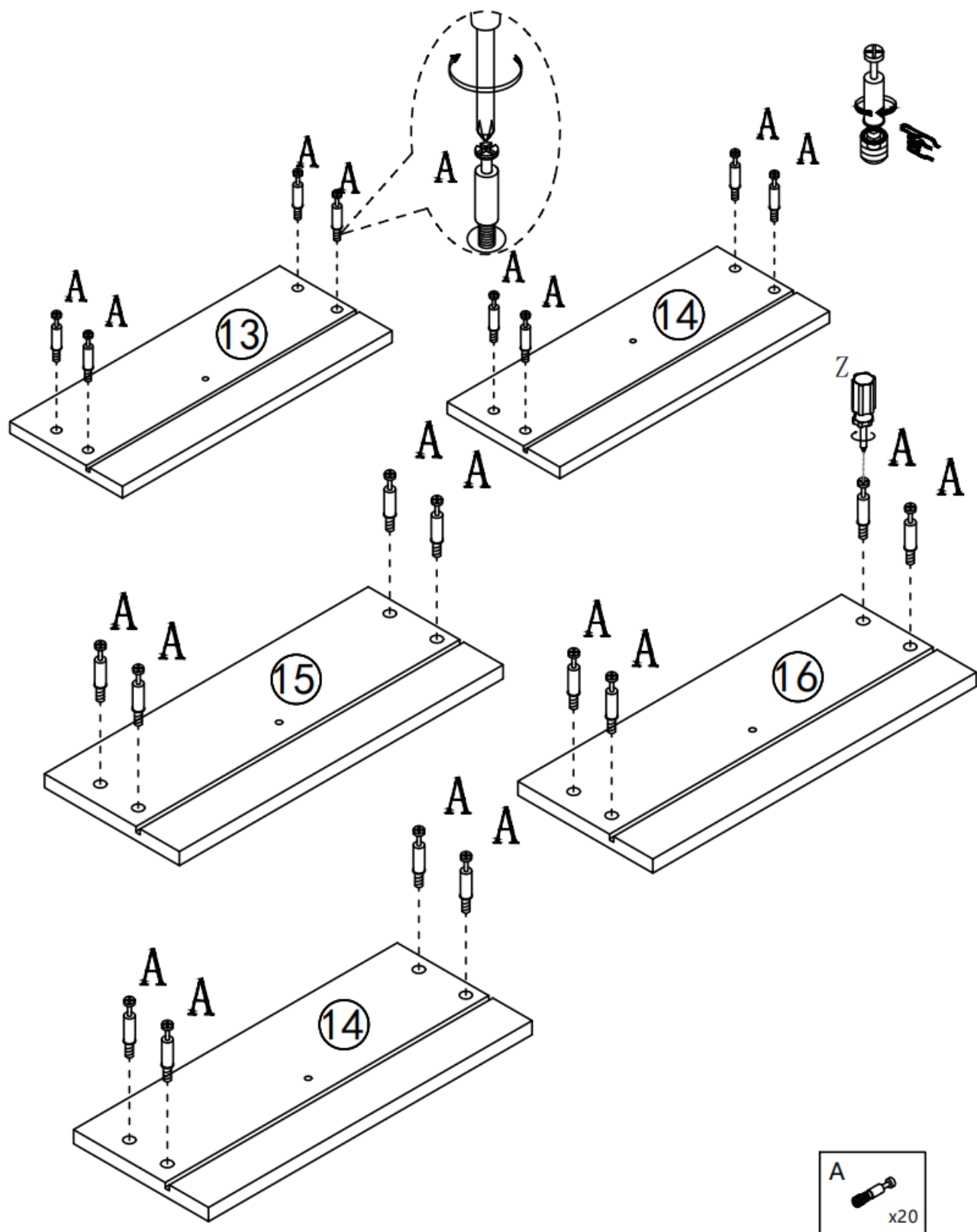

STEP 3

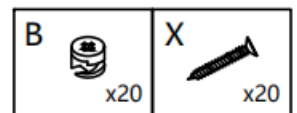
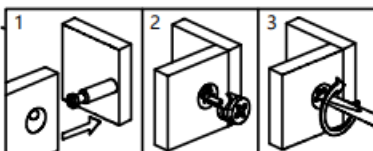
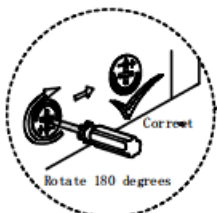
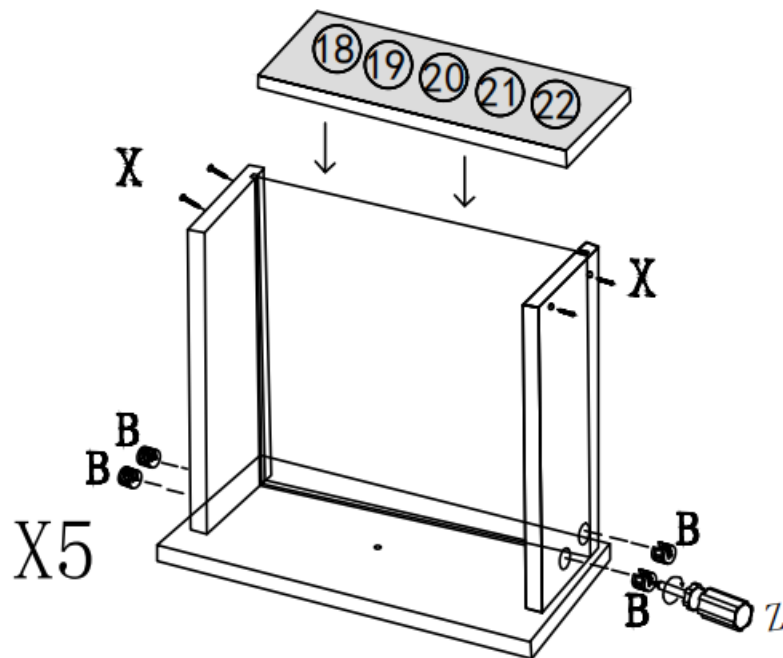
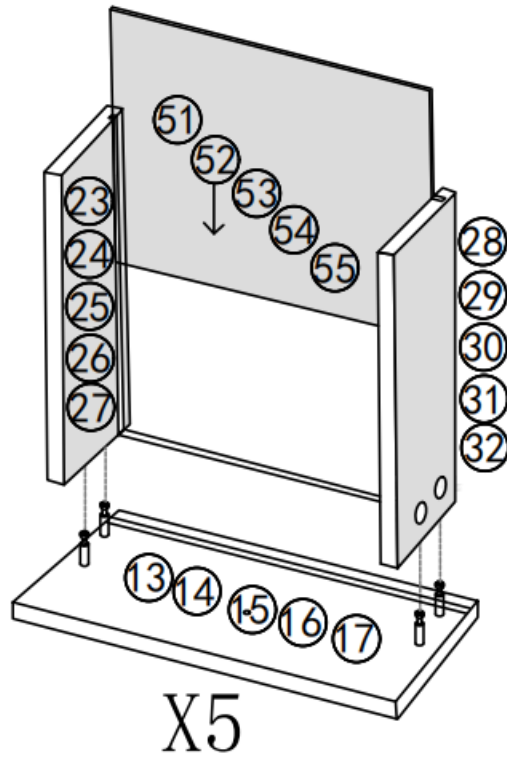



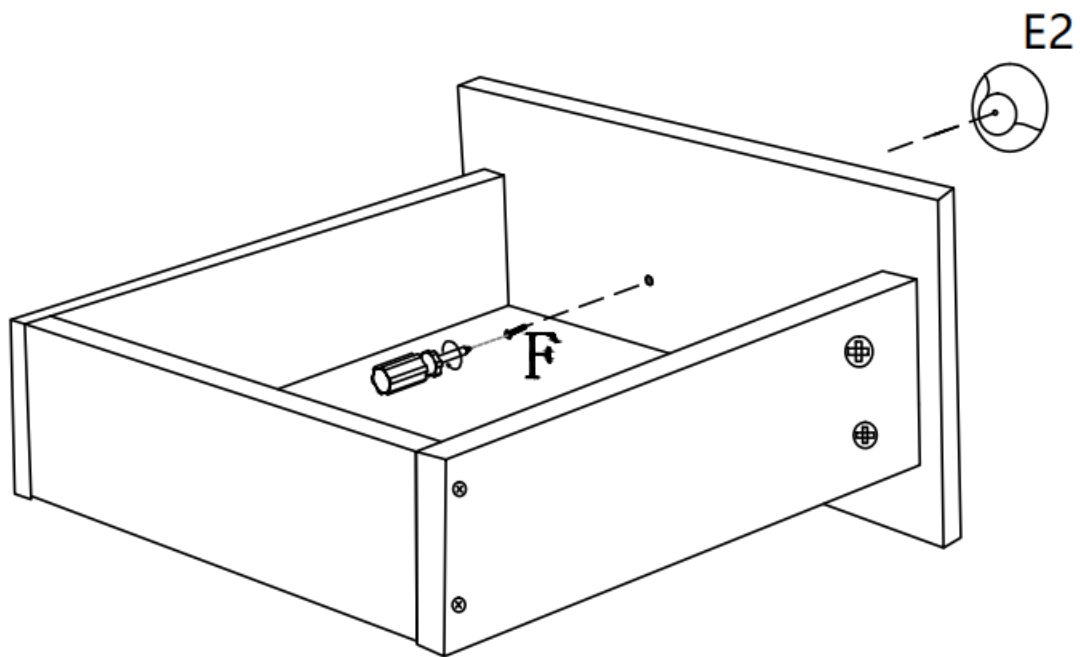

STEP 4

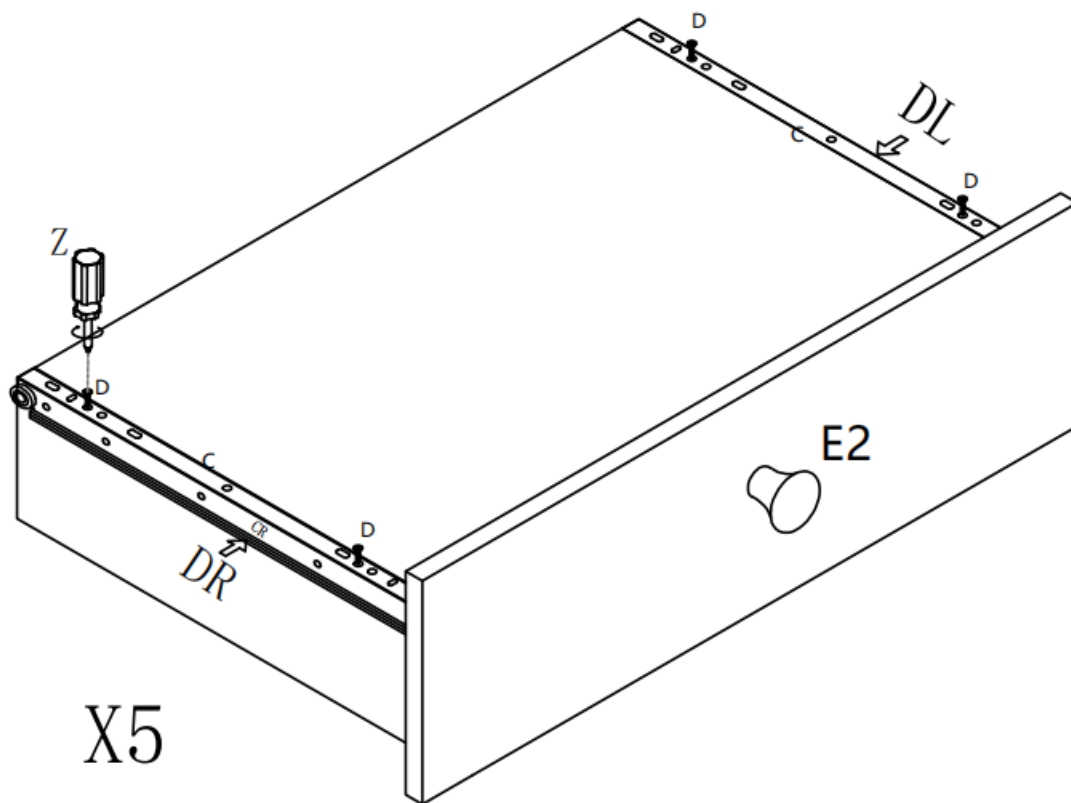

X5



X5



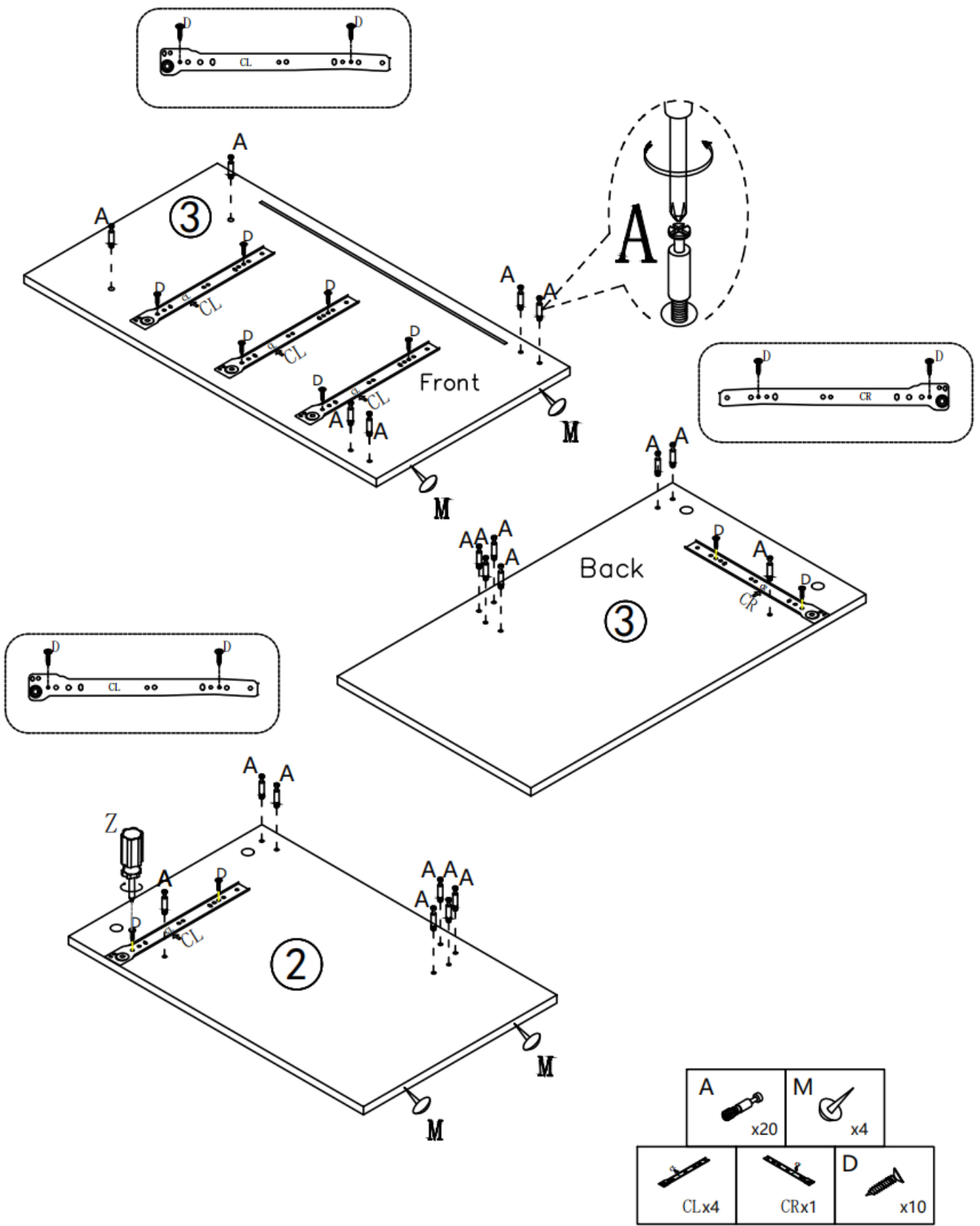

 E2 x5	 F x5	
 DRx5	 DLx5	 D x20

STEP 5

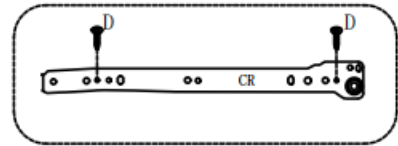
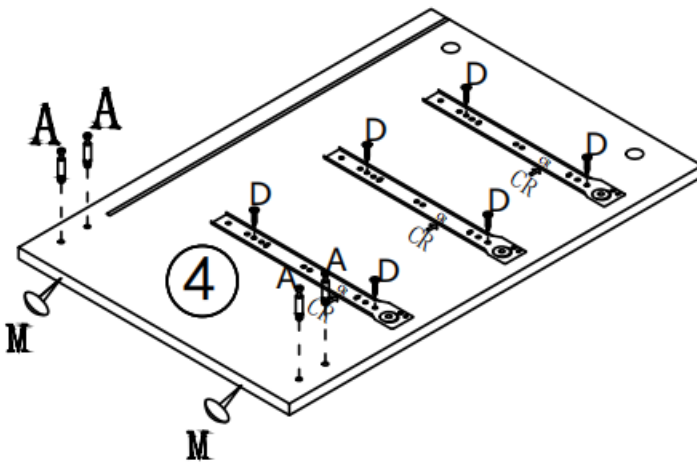
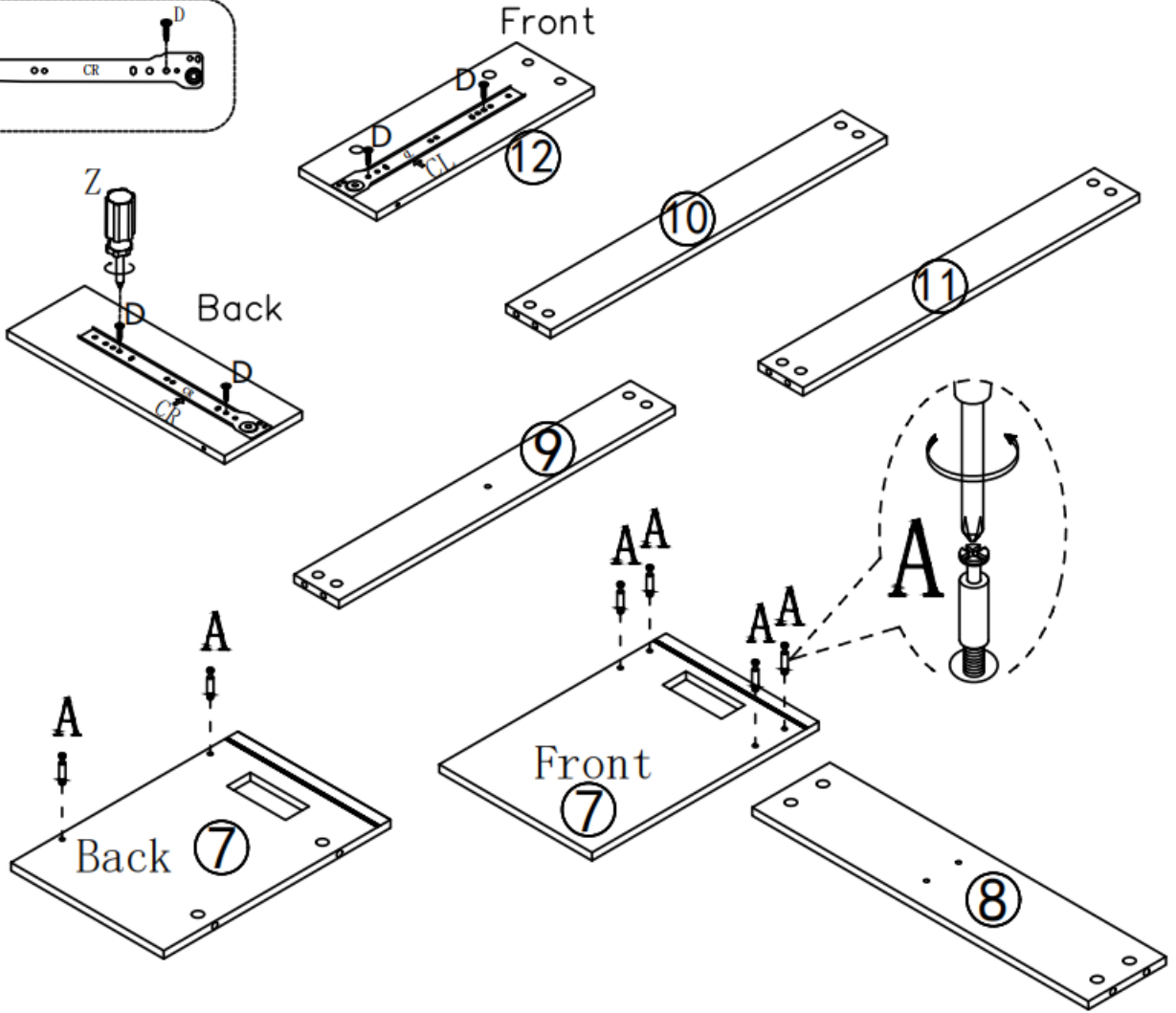
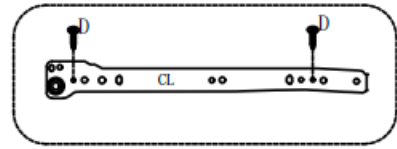
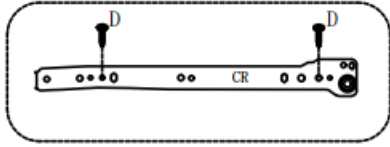

STEP 6



 x10	 x2	
 CLx1	 CRx4	 D x10

STEP 7

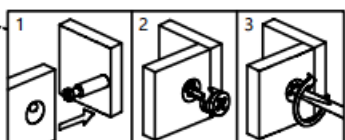
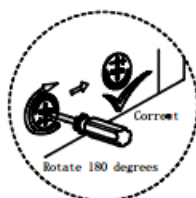
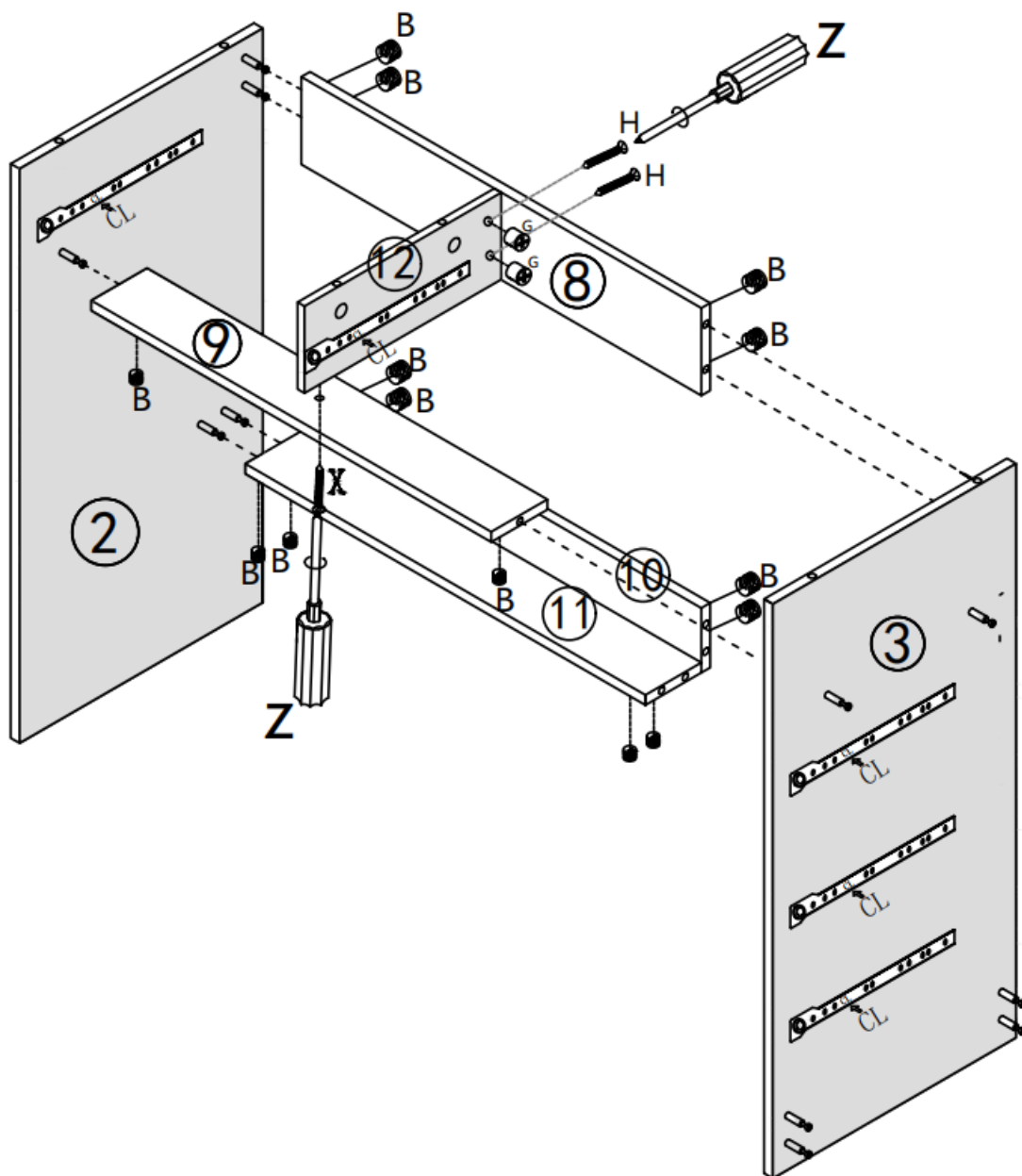

X x1	B x14
G x2	H x2

STEP 8

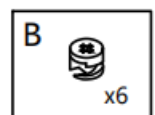
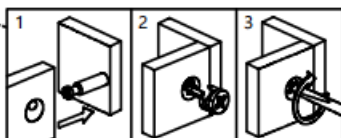
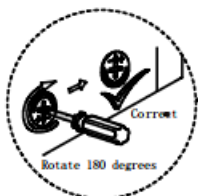
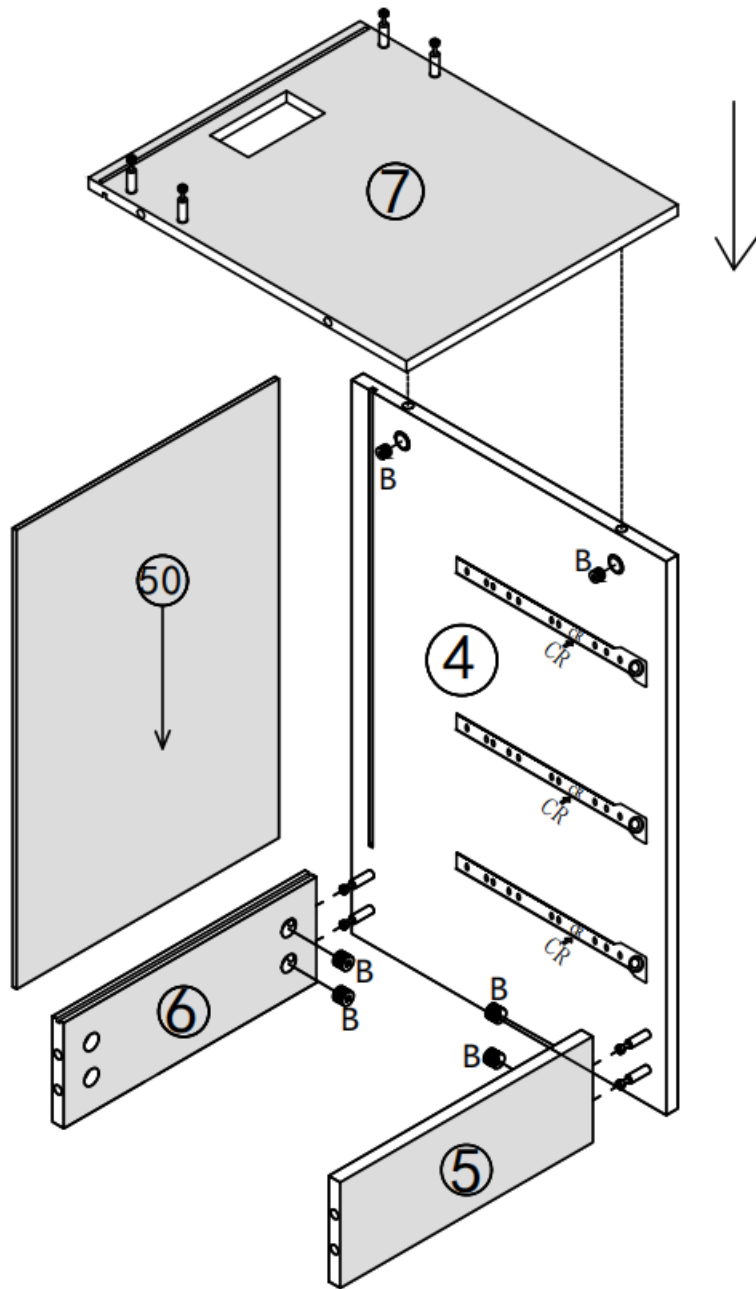

STEP 10

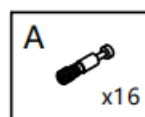
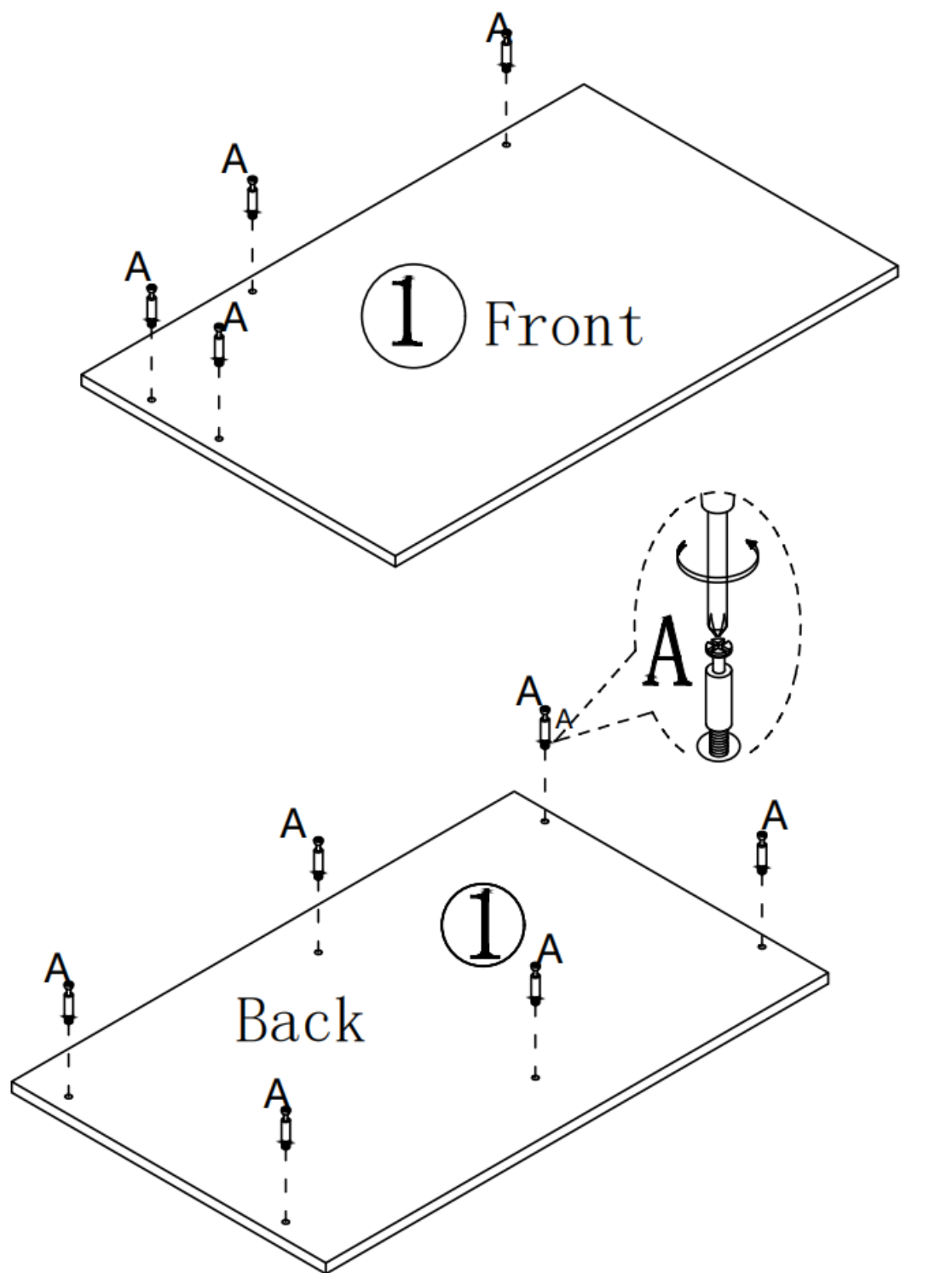

STEP 13

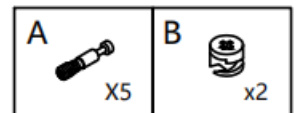
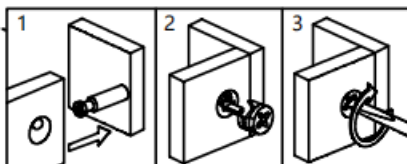
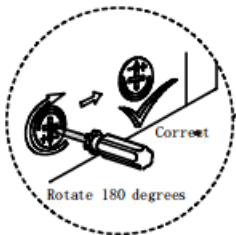
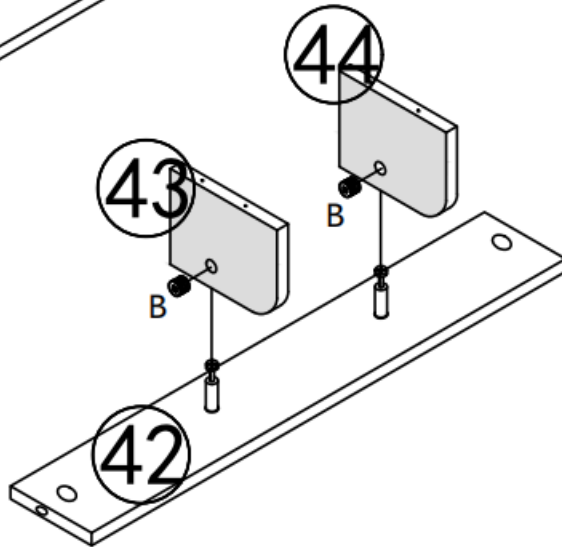
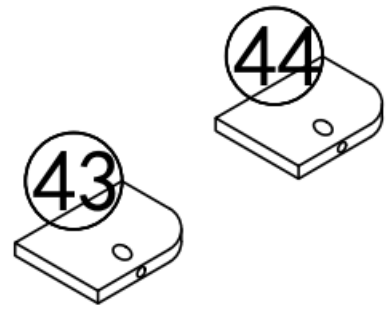
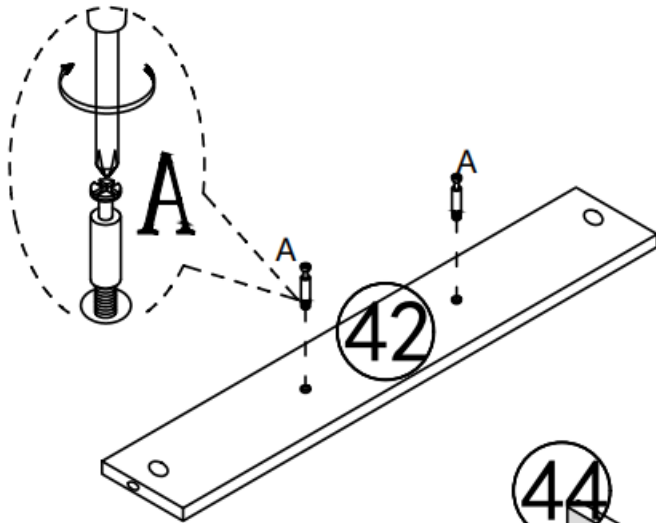
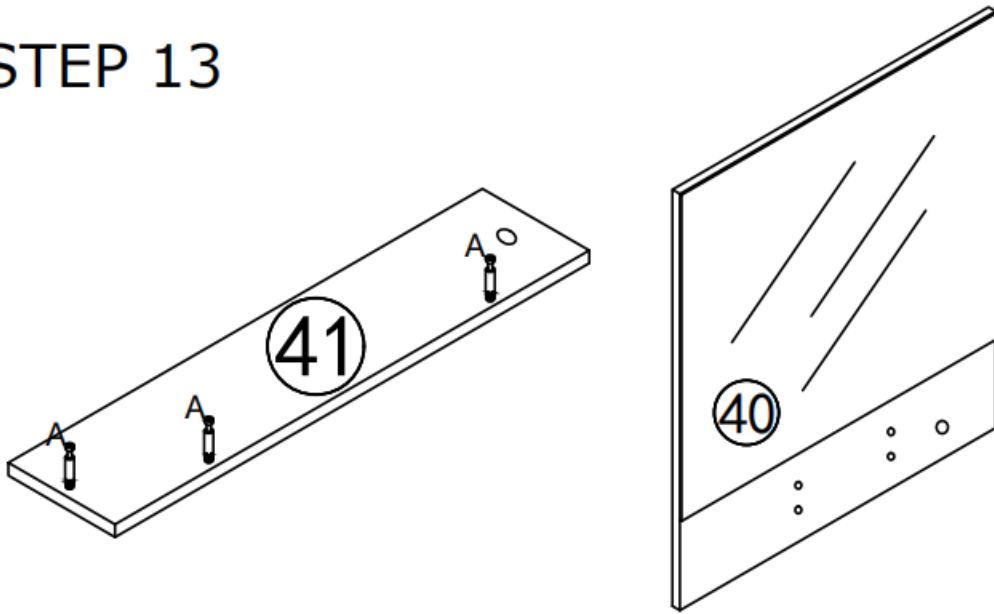

STEP 14

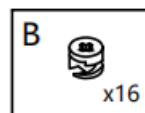
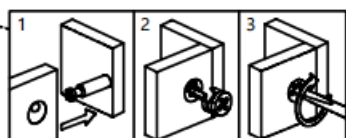
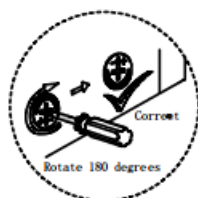
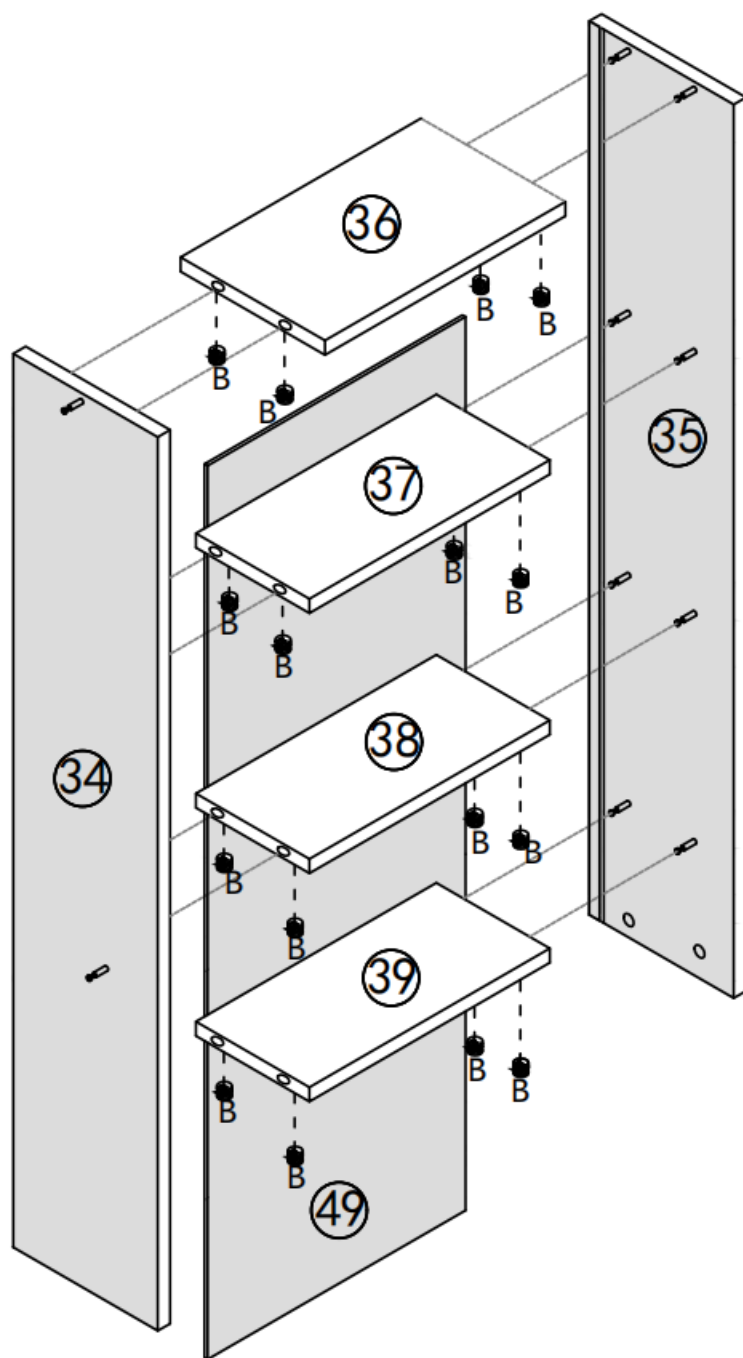

STEP 15

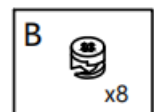
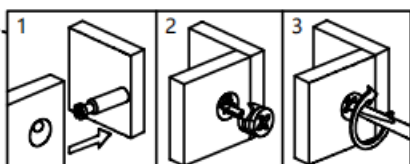
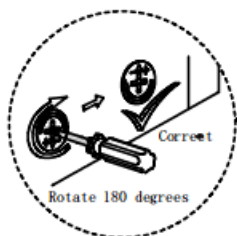
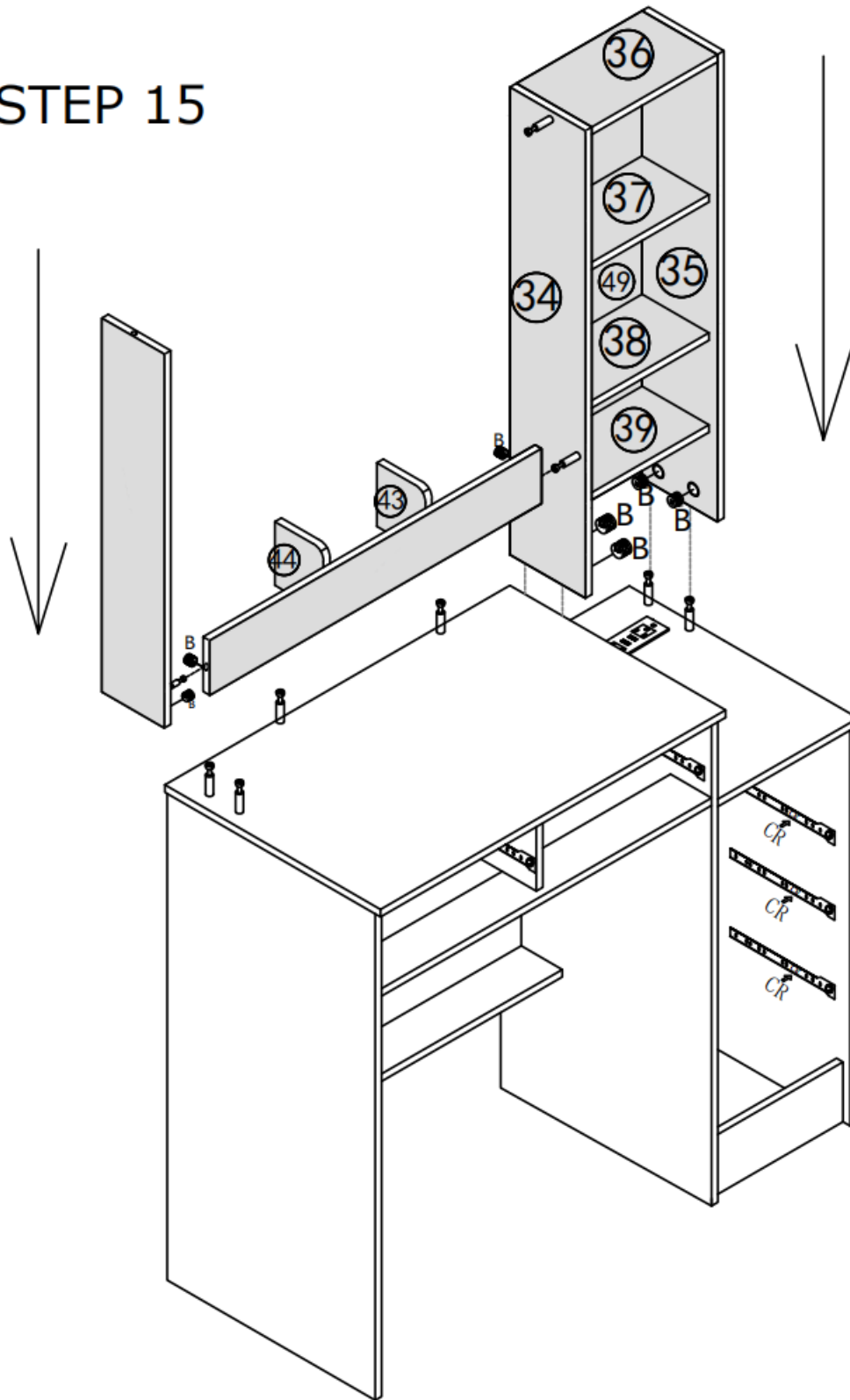

STEP 16

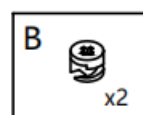
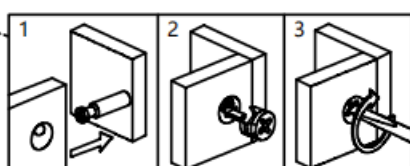
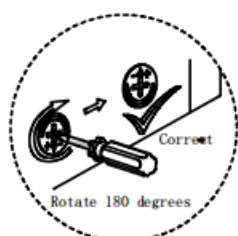
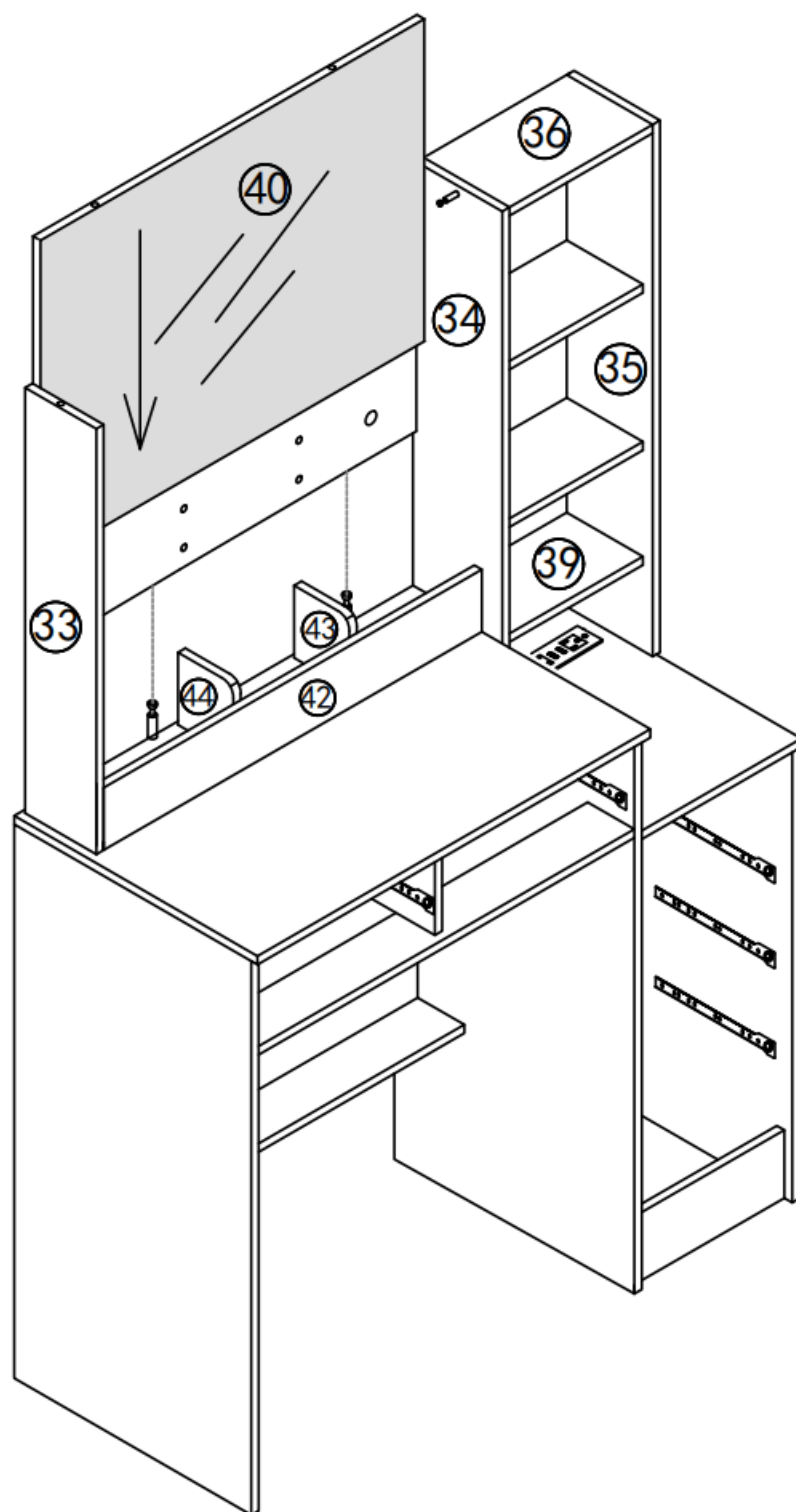

STEP 17

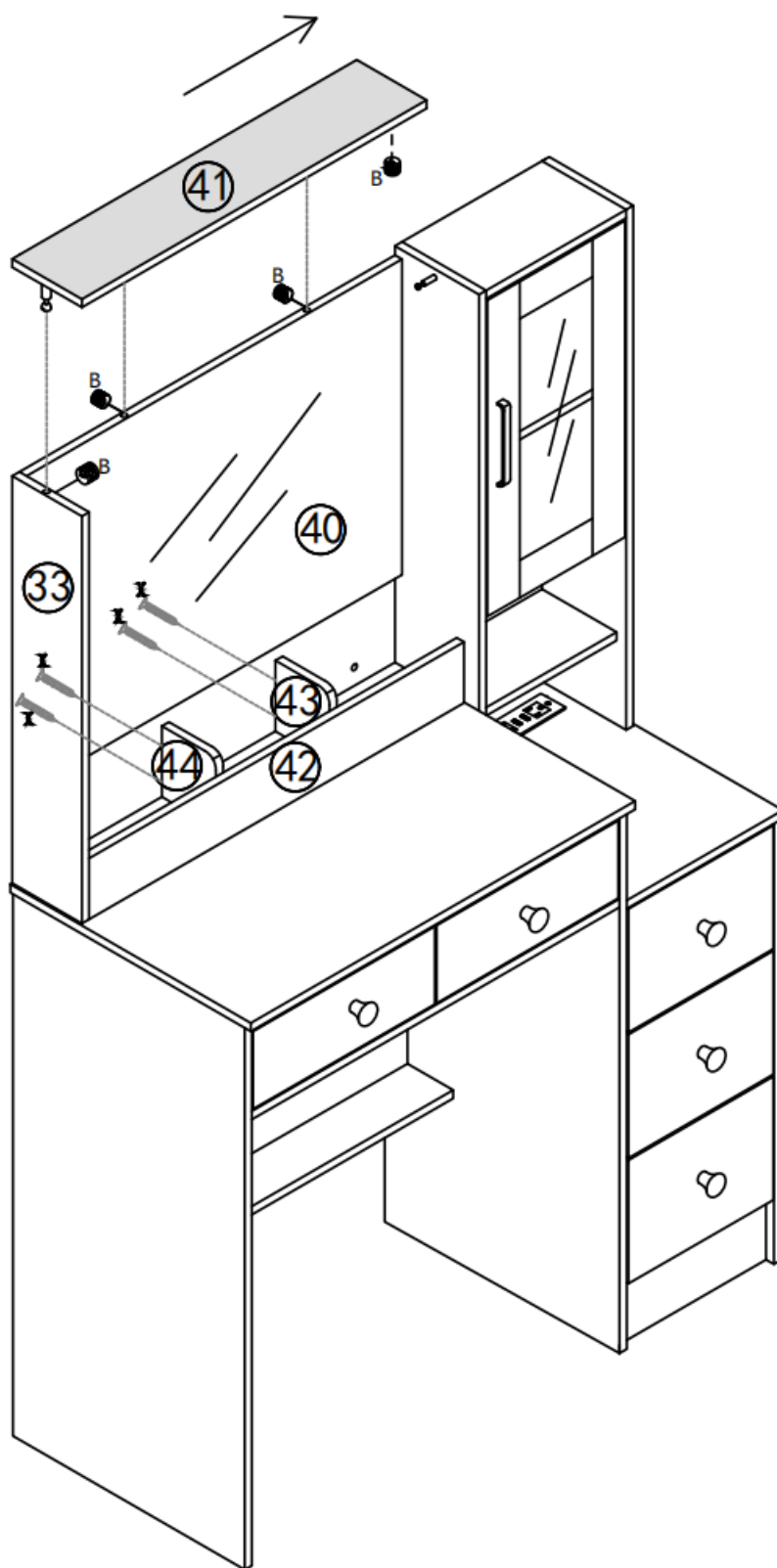

21

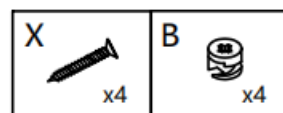



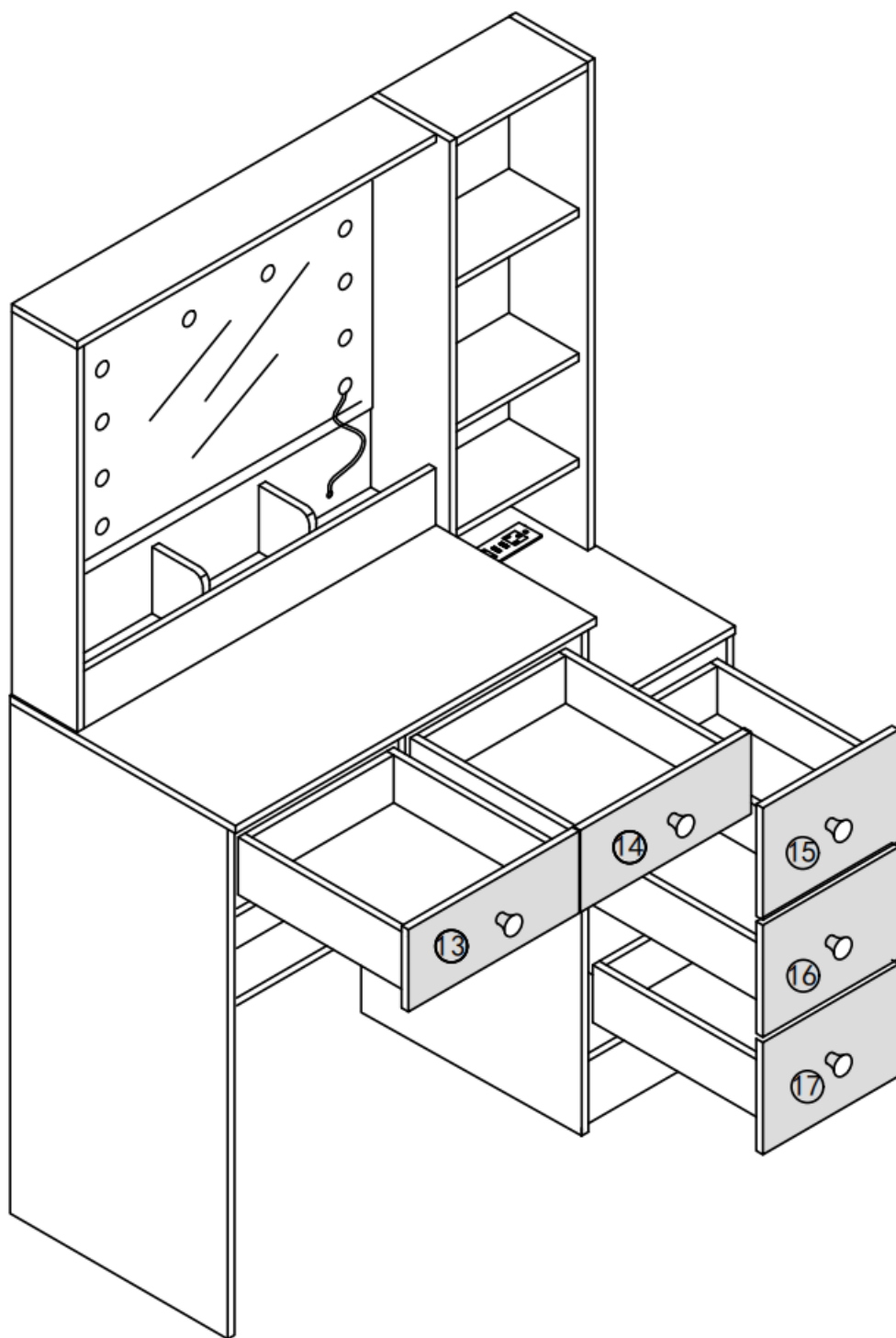

STEP 18

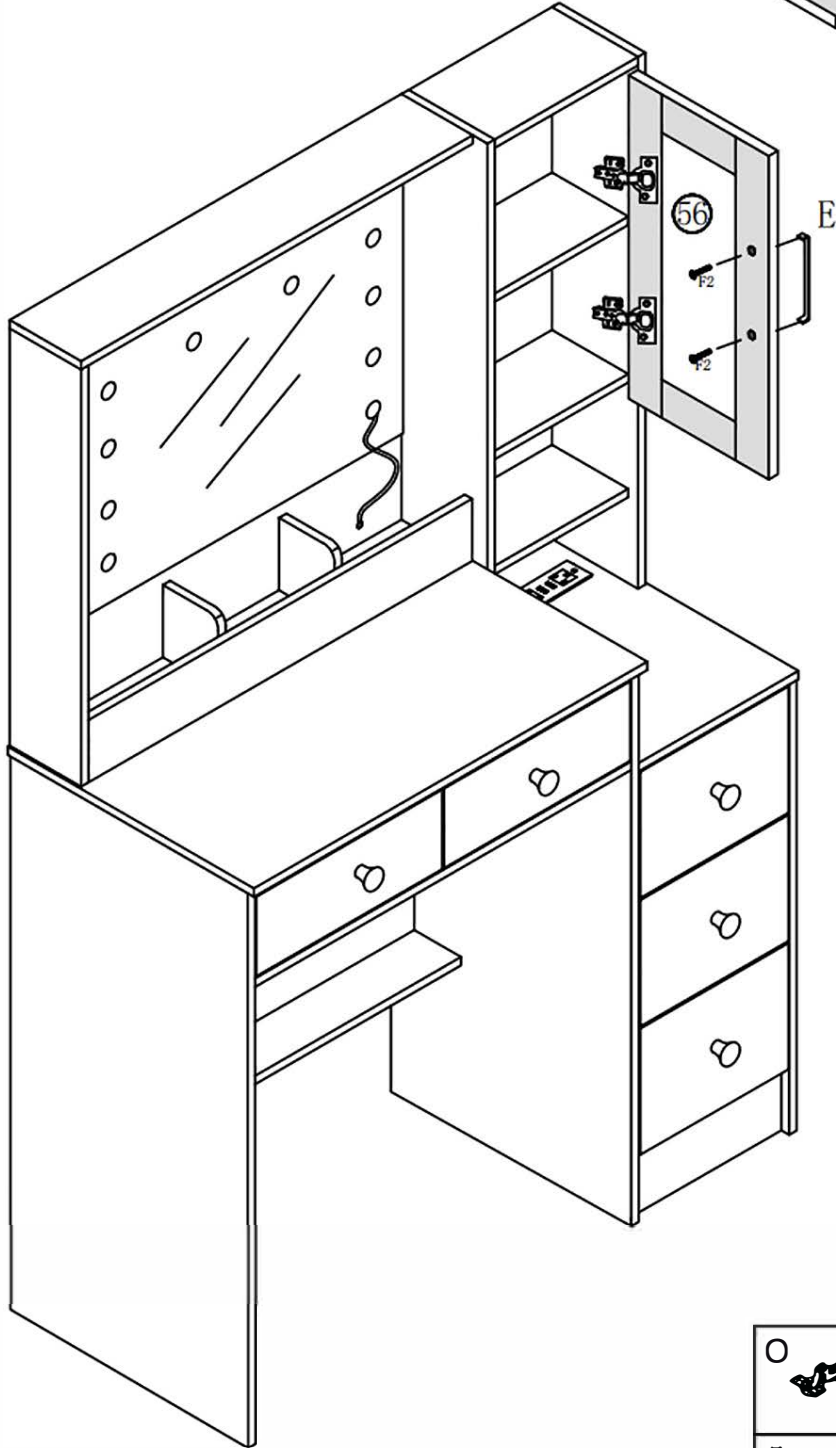
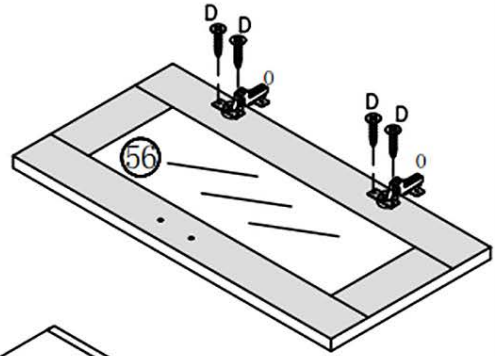

STEP 19



O	D
	
x2	x12
E	F2
	
x1	x2