

Installation & Assembly

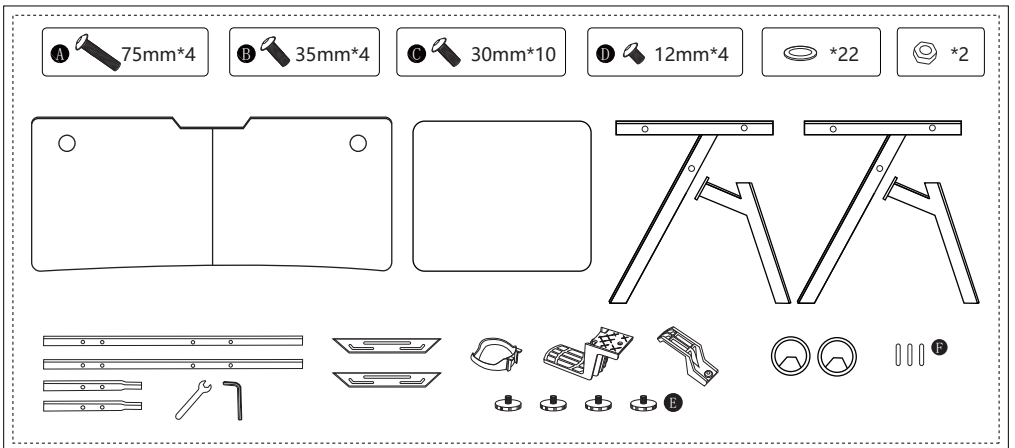

Fix the two desktops

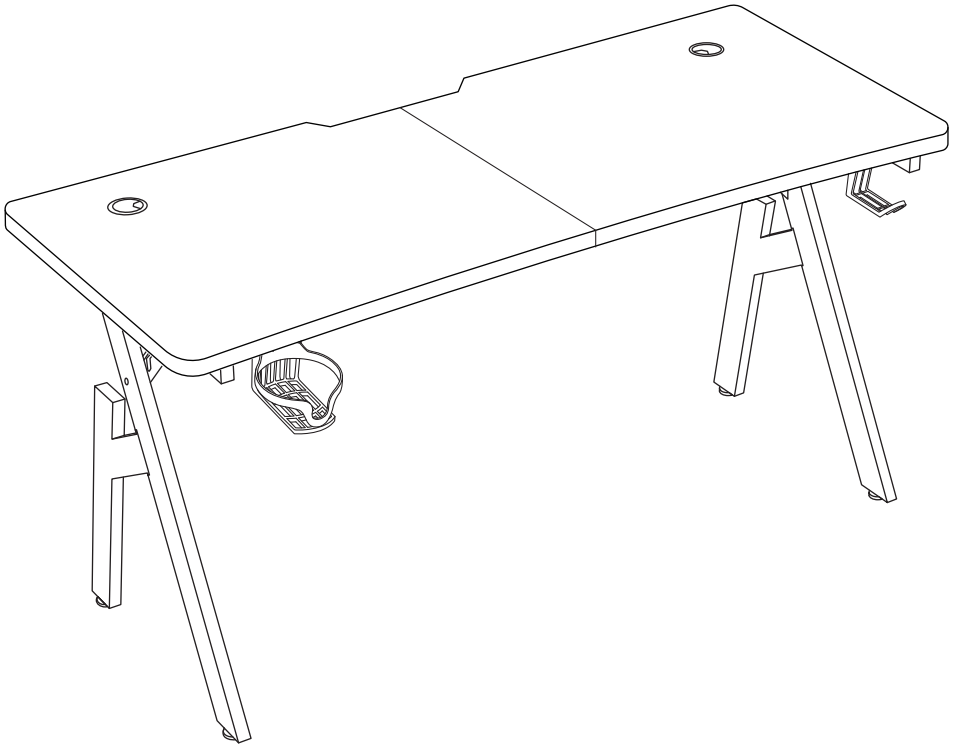
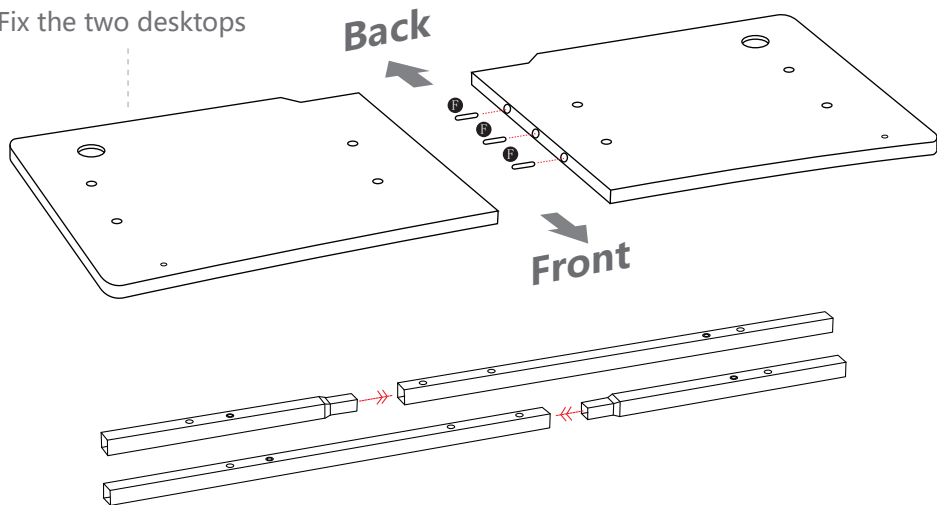

! Insert the short metal rod into the long metal rod. Please install as shown.

C Bolt 30mm*8

Washer *8

Bolt (30mm)

Washer

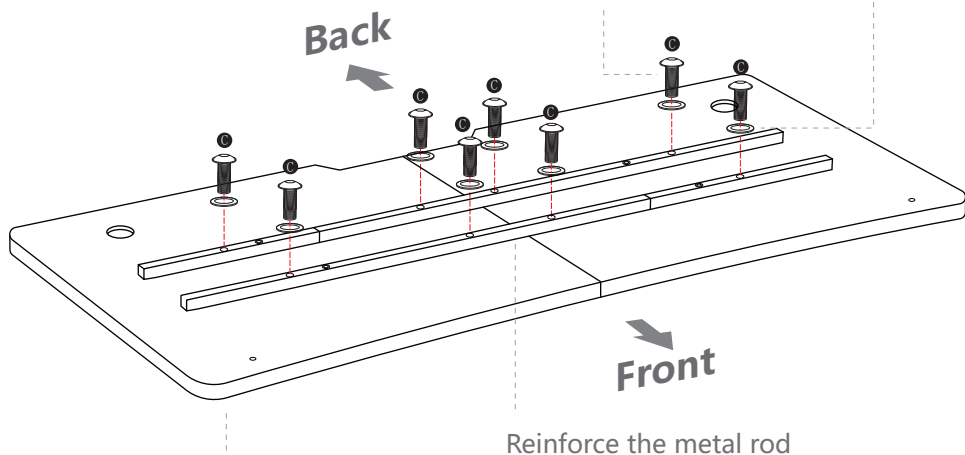

Attach the metal rod to the desktop

B  35mm*4

 *4

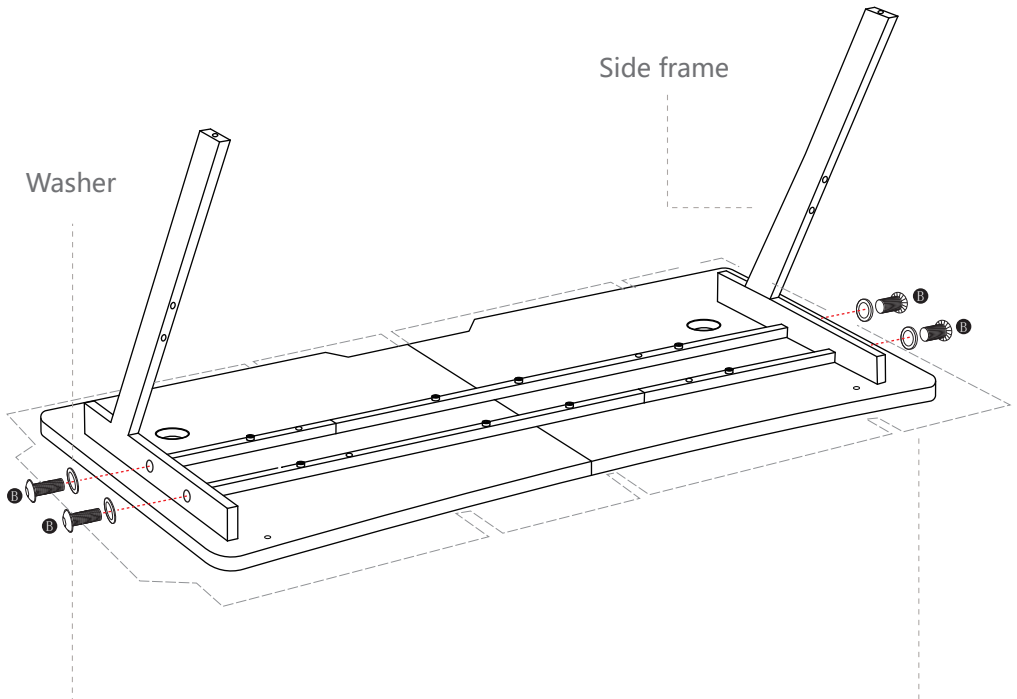

Bolt (35mm)

※ Note: Please leave it a bit loose

You can lay the packaging box flat on the ground to use as padding, preventing direct contact between the desktop and the floor, which could cause wear.

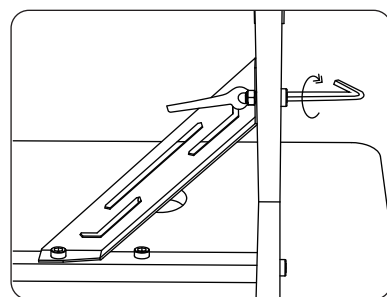
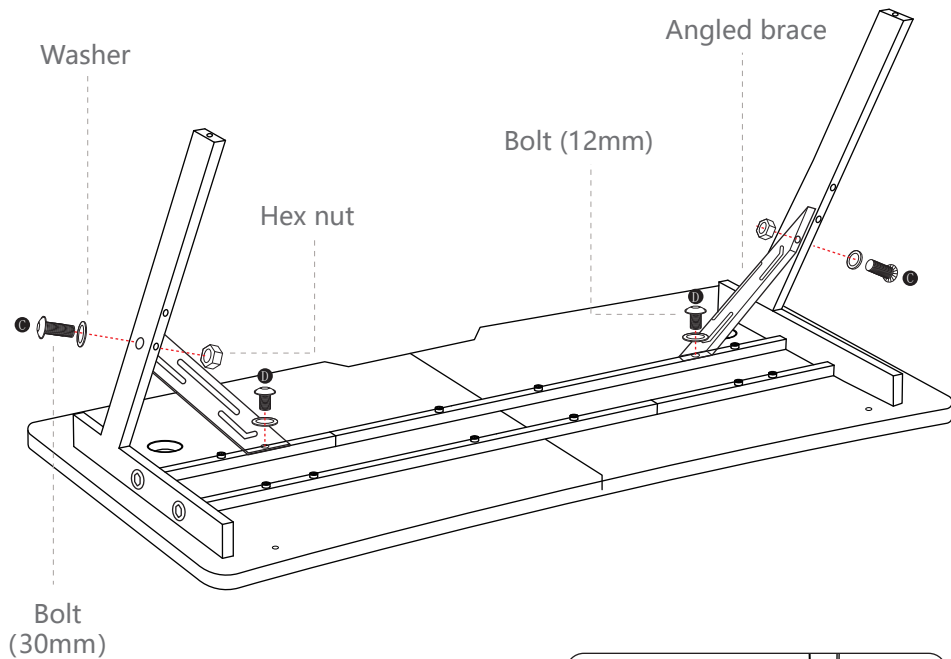

⚠ Please do not tighten the screws too much during assembly. Be especially careful not to fully tighten all the screws until they are all in place.



75mm*4



*4

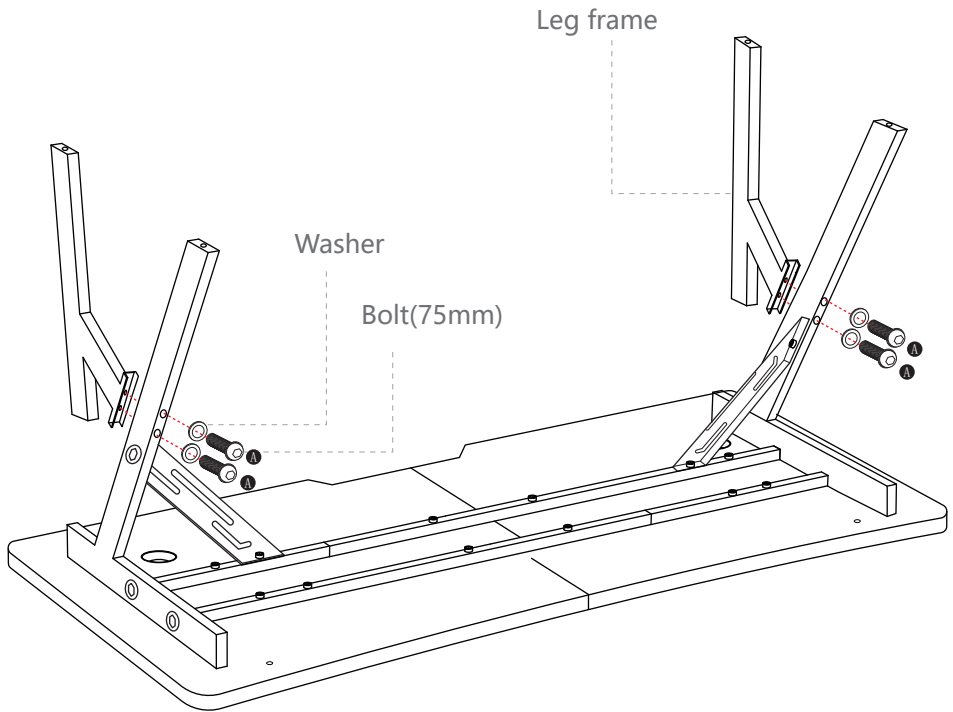

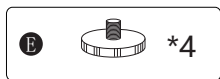

Foot pad

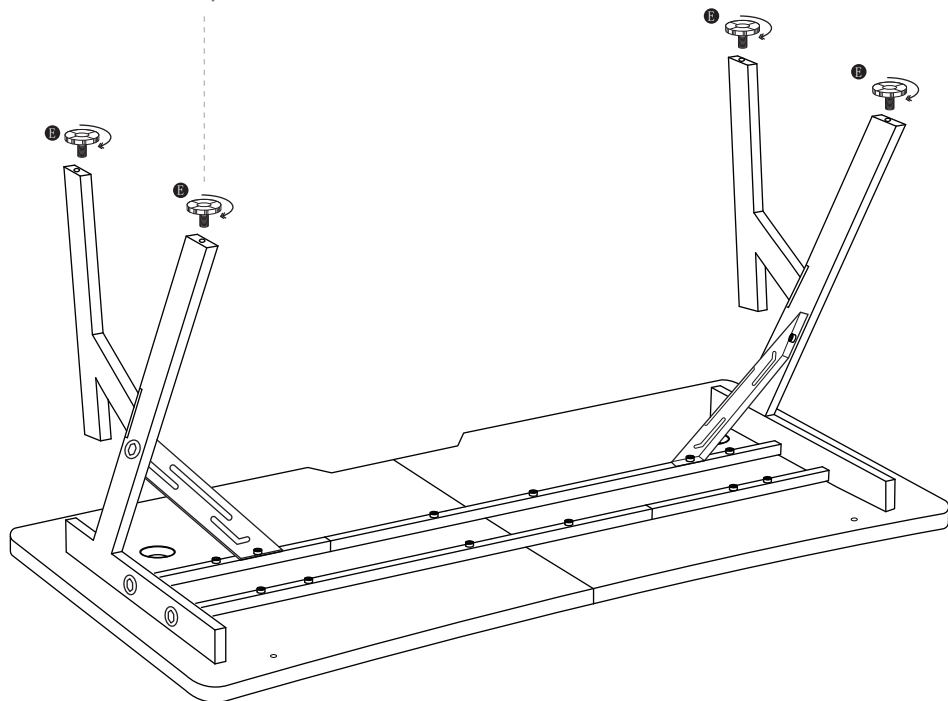

Install the foot pads.

① 12mm*2

*2

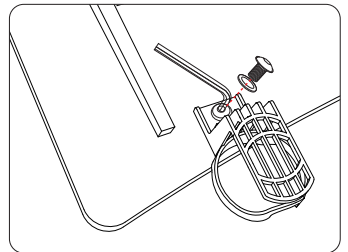
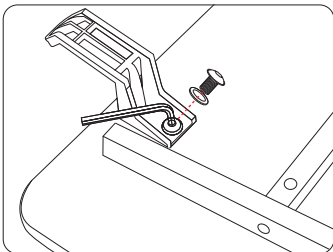
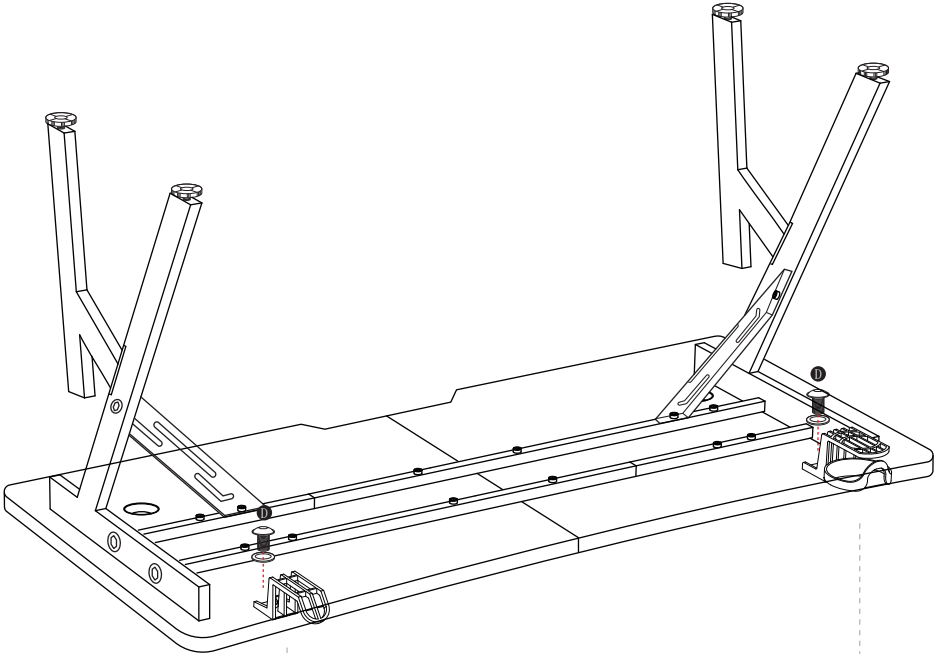
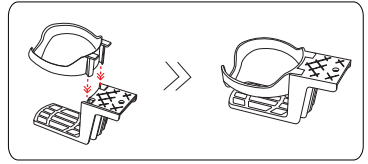

Install the cup holder and headphone hook.

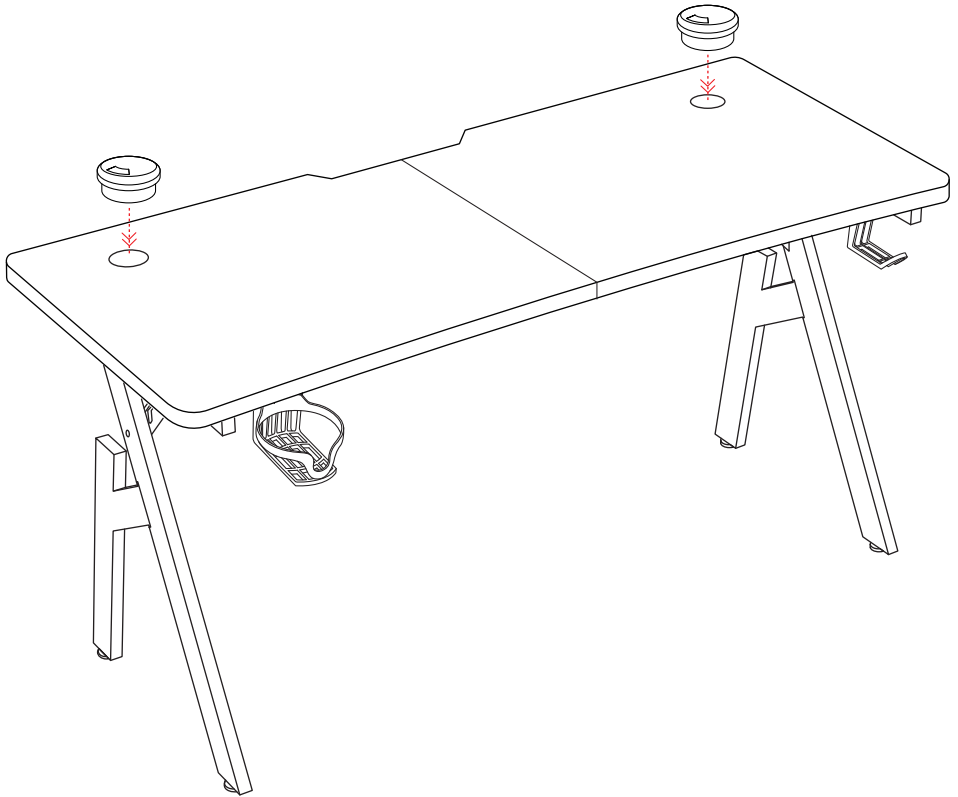
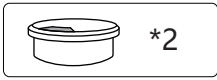

Attach the cable management to the desktop, and it's complete.

Die beiden Tischplatten befestigen

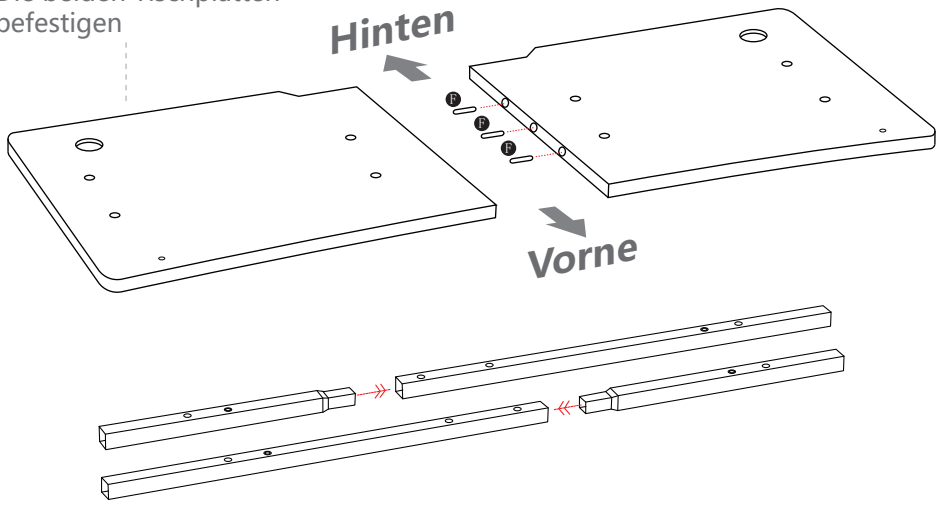

! Stecken Sie die kurze Metallstange in die lange Metallstange. Installieren Sie es wie im Diagramm gezeigt.

C  30mm*8

 *8

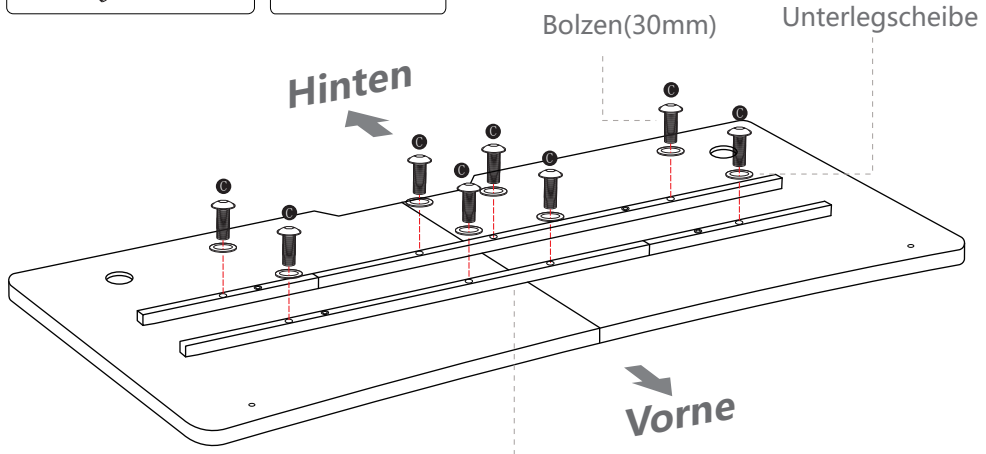

Befestigen Sie die Metallstange an der Tischplatten

Verstärken Sie die Metallstange

 35mm*4

 *4

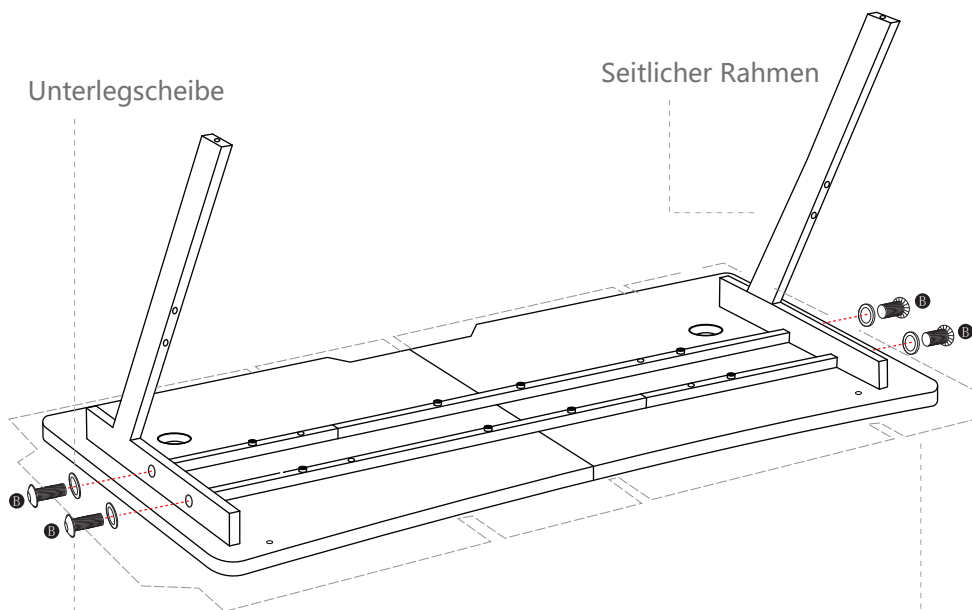

Unterlegscheibe

Seitlicher Rahmen

Bolzen(35mm)

※ Bitte lassen Sie es ein wenig locker

Sie können den Karton flach auf den Boden legen und als Unterlage verwenden, um zu verhindern, dass die Tischplatte direkt mit dem Boden in Kontakt kommt und dadurch beschädigt wird.

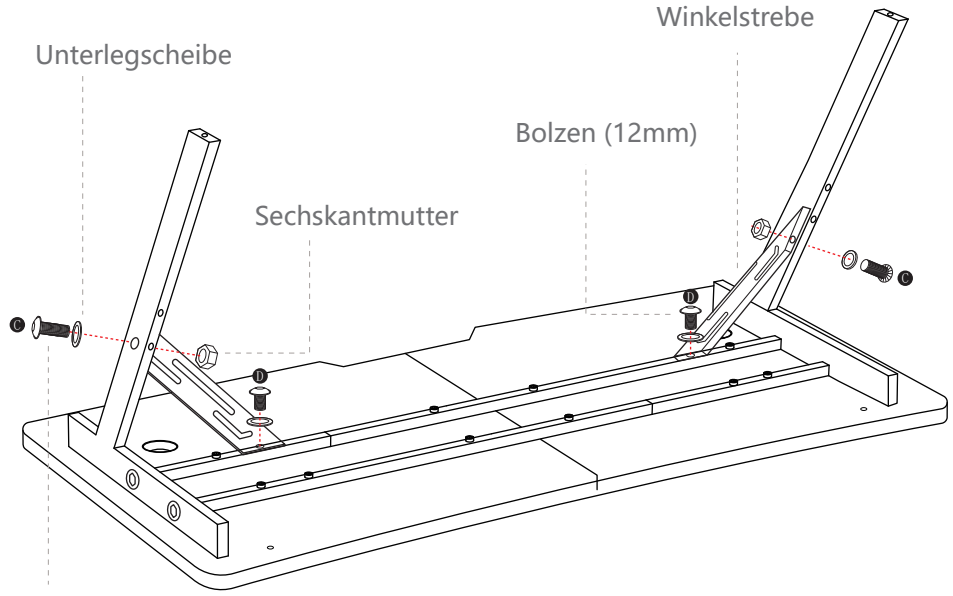
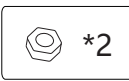
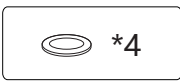

Bolzen (30mm)

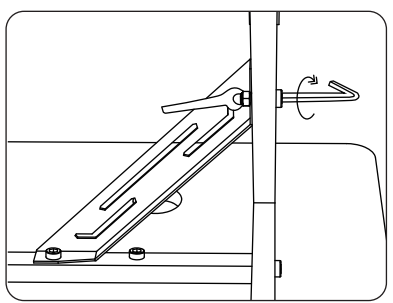

! Bitte ziehen Sie die Schrauben während der Montage nicht zu fest an. Achten Sie besonders darauf, alle Schrauben nicht festzuziehen, bis sie an ihrem Platz sind.

 75mm*4

 *4

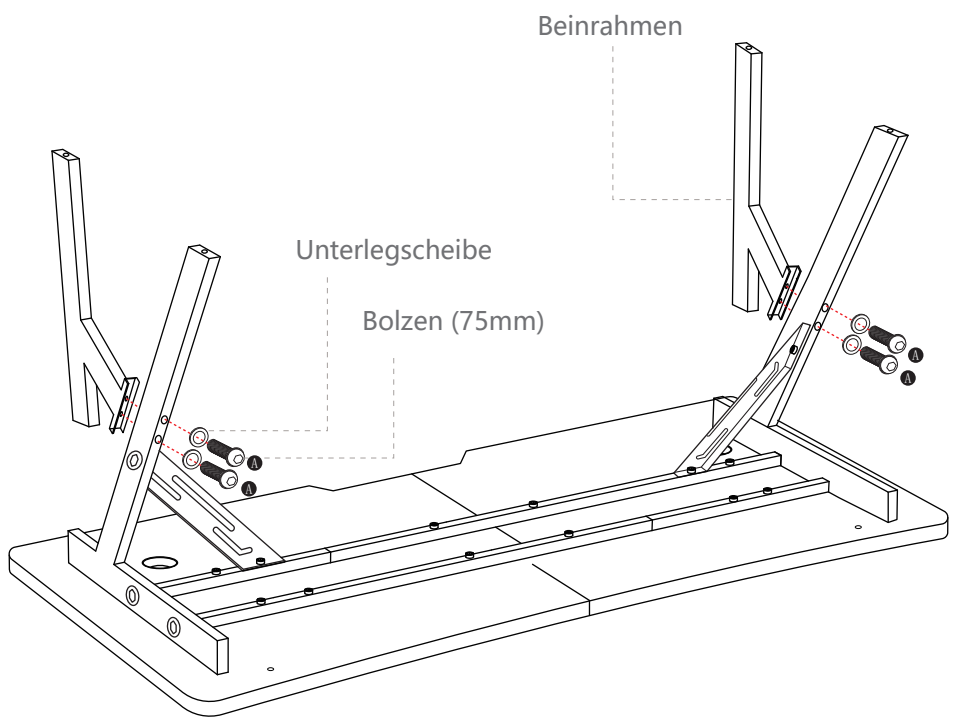

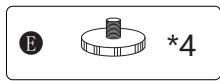

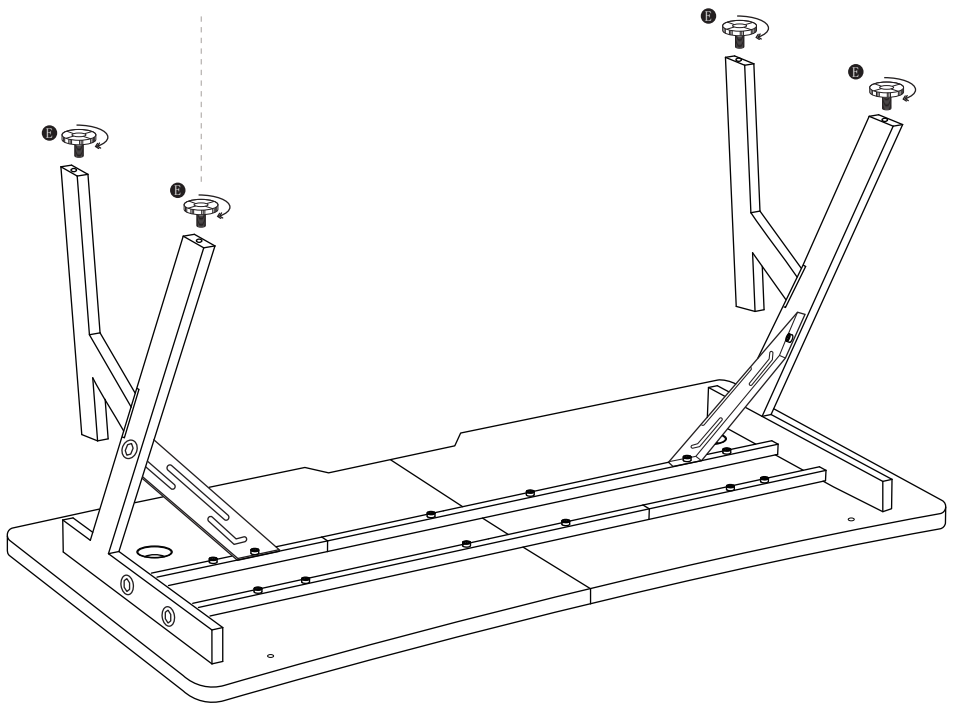

FüÙe



Montieren Sie die FüÙe.

- ①  12mm*2
-  *2

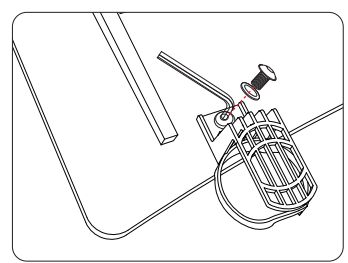
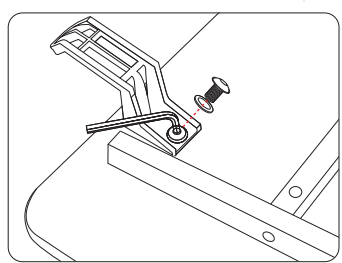
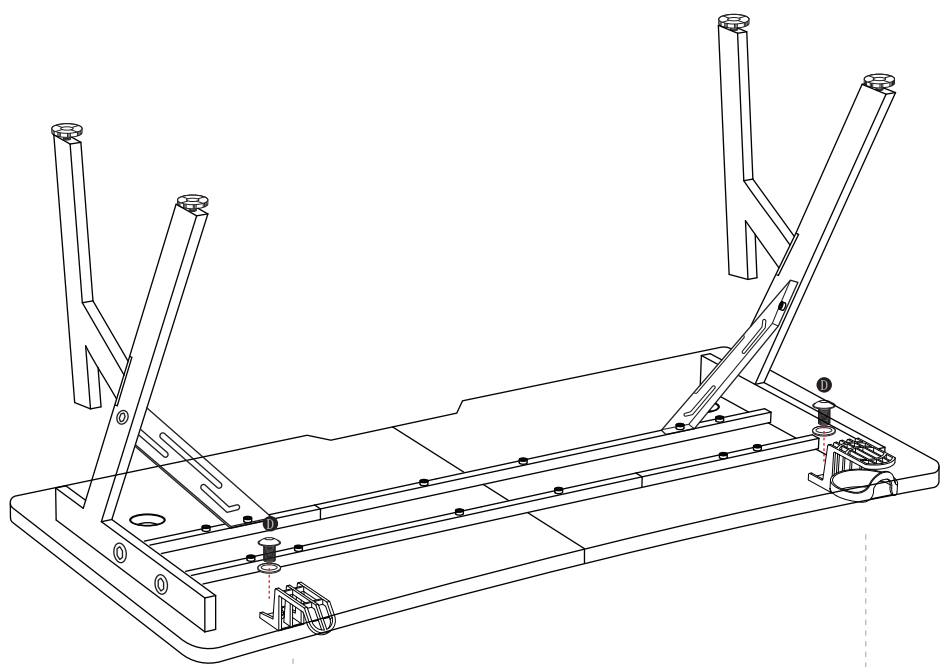
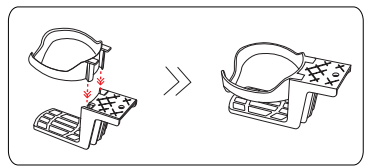

Befestigen Sie den Becherhalter und den Kopfhörerständer.

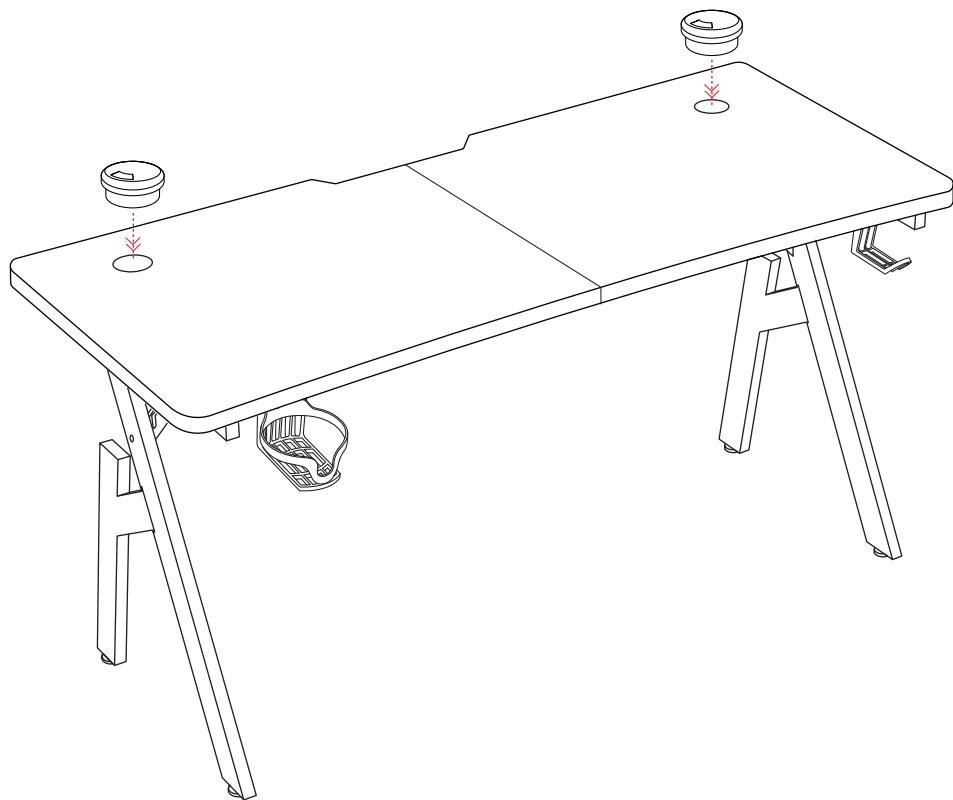
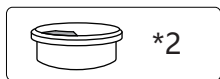

Bringen Sie das Kabeldurchführung an der Tischplatten an, und schon ist es fertig.

Fissare i due piani
del tavolo

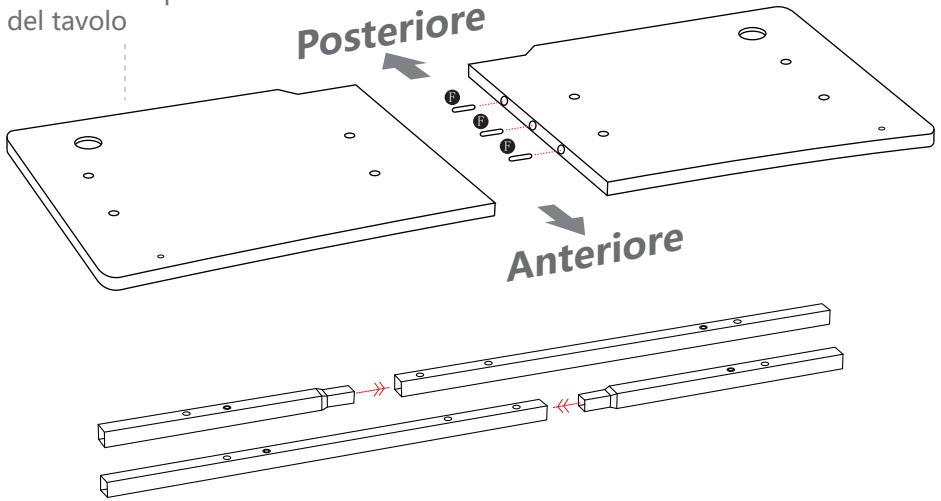

! Inserire l'asta di metallo corta nell'asta di metallo lunga.
Installare come mostrato nel

C  30mm*8

 *8

Bullone (30mm)

Rondella

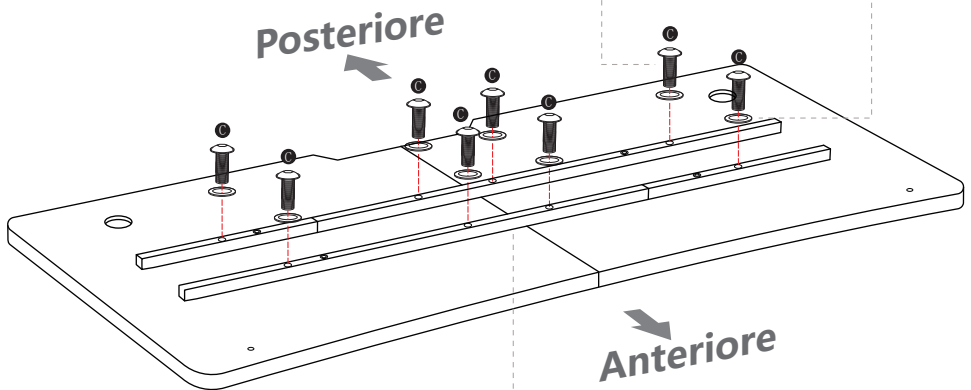

Fissare l'asta di metallo alla
piani del tavolo

B  35mm*4

 *4

Rondella

Telaio laterale

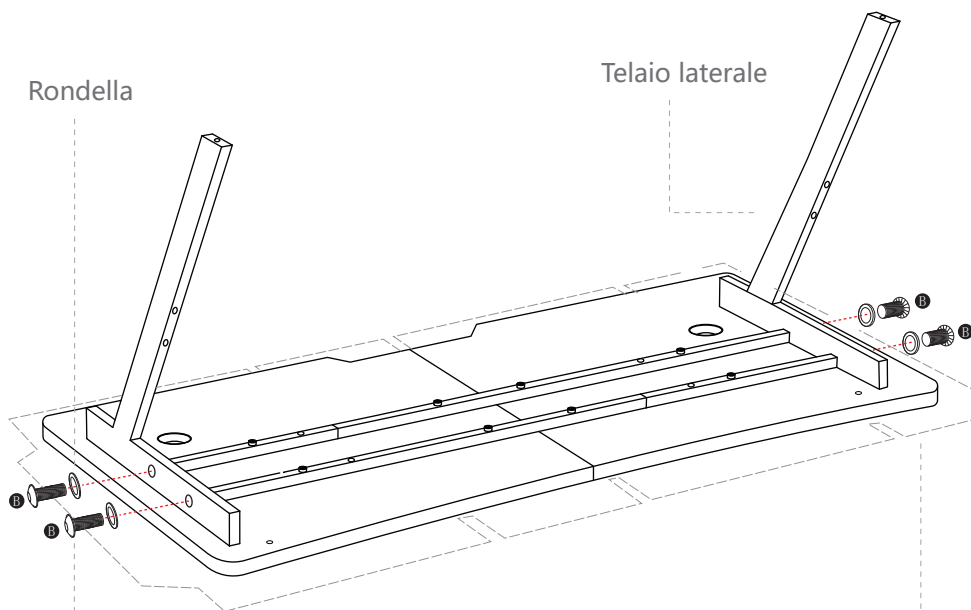

Bullone (35mm)

✳ Per favore, lascialo un po' allentato

Può stendere il cartone dell'imballaggio sul pavimento e usarlo come tappetino per evitare che il piano del tavolo entri in contatto diretto con il pavimento e si danneggi.

ⓐ  30mm*2

ⓑ  12mm*2

 *4

 *2

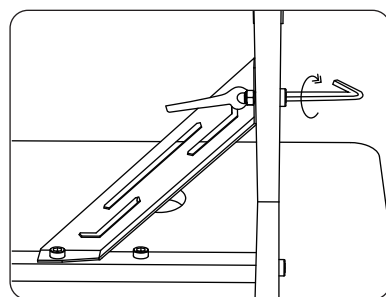
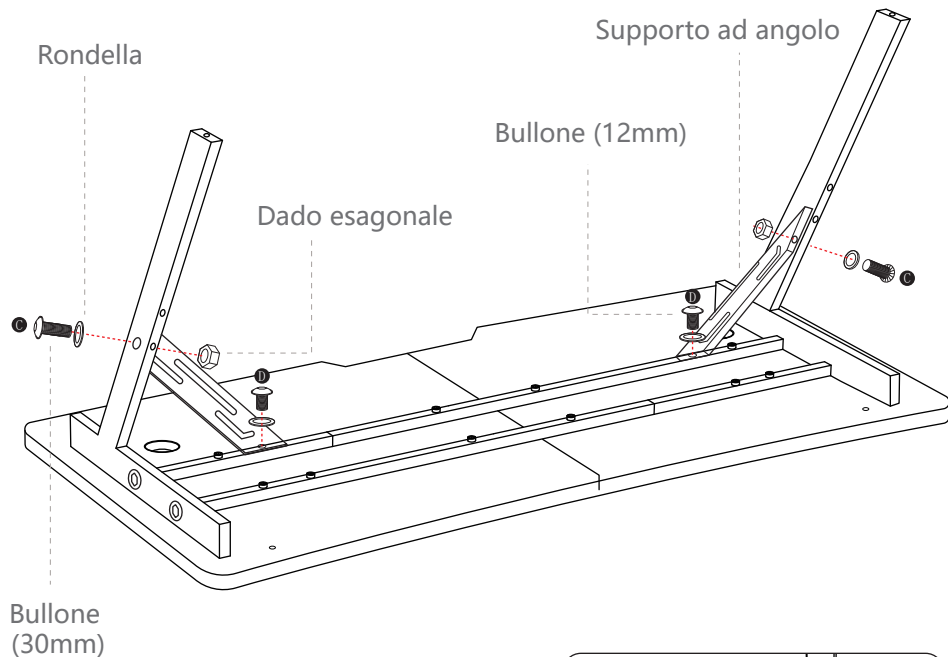

⚠ Si prega di non stringere troppo le viti durante il montaggio. Prestare particolare attenzione a non stringere completamente tutte le viti finché non sono tutte in posizione.

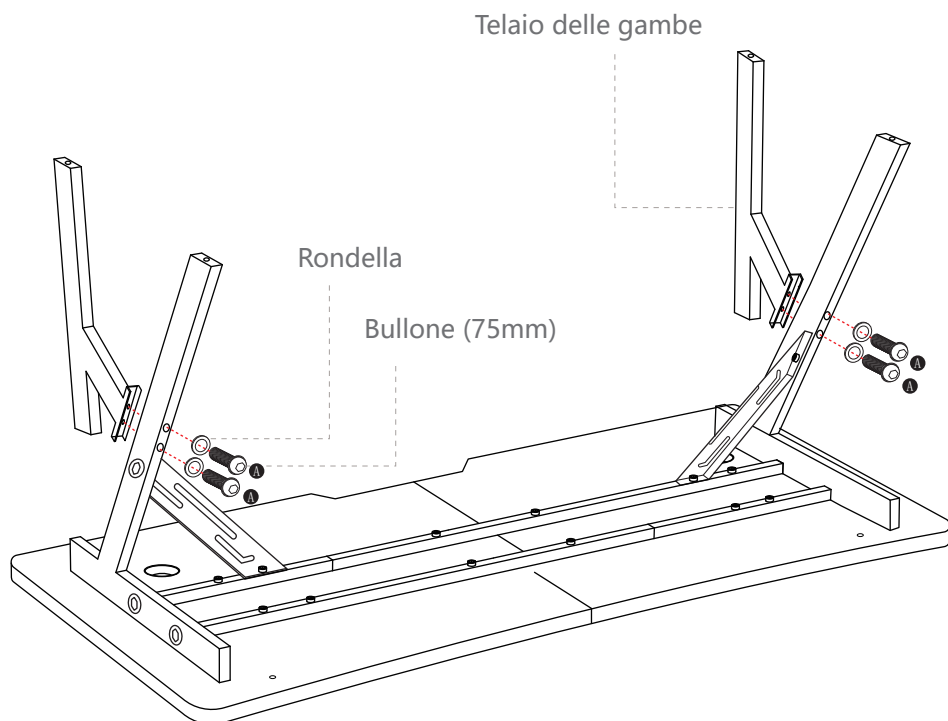
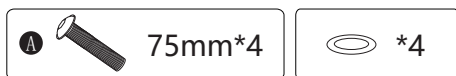

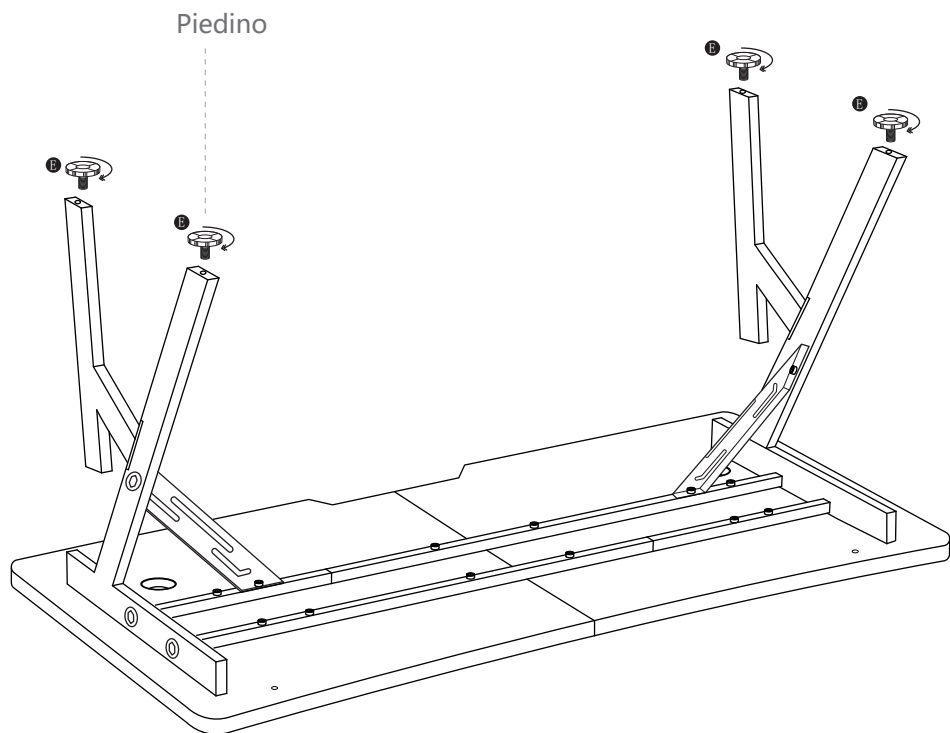
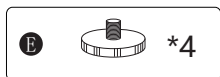

Installare i piedini.

①  12mm*2

 *2

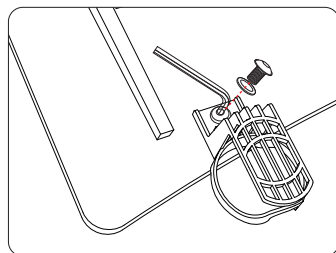
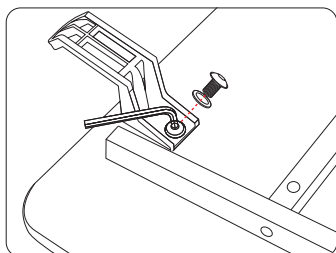
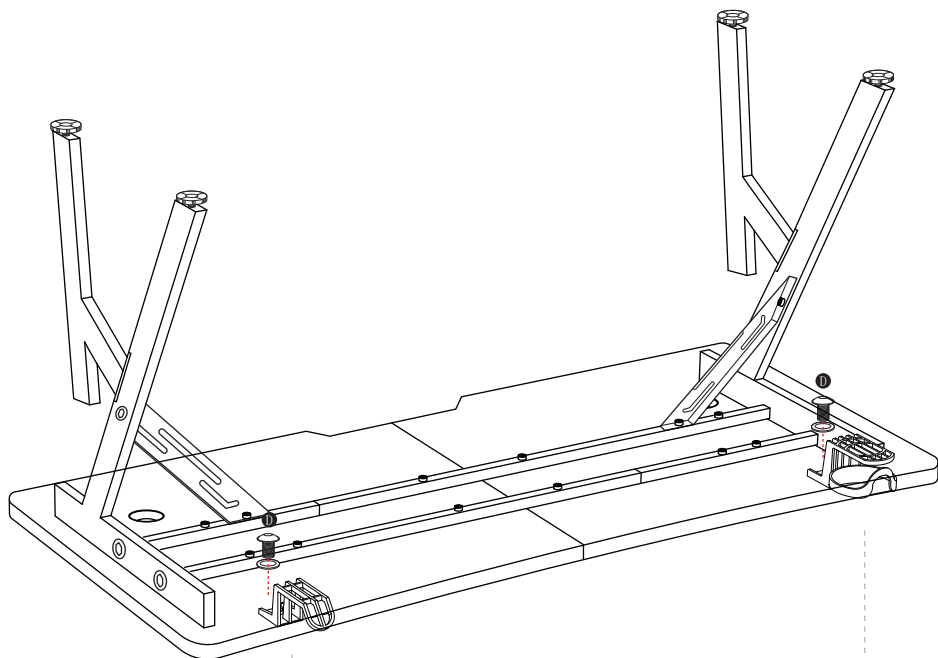
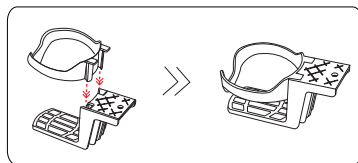

Installare il Porta bicchieri e gancio per cuffie.

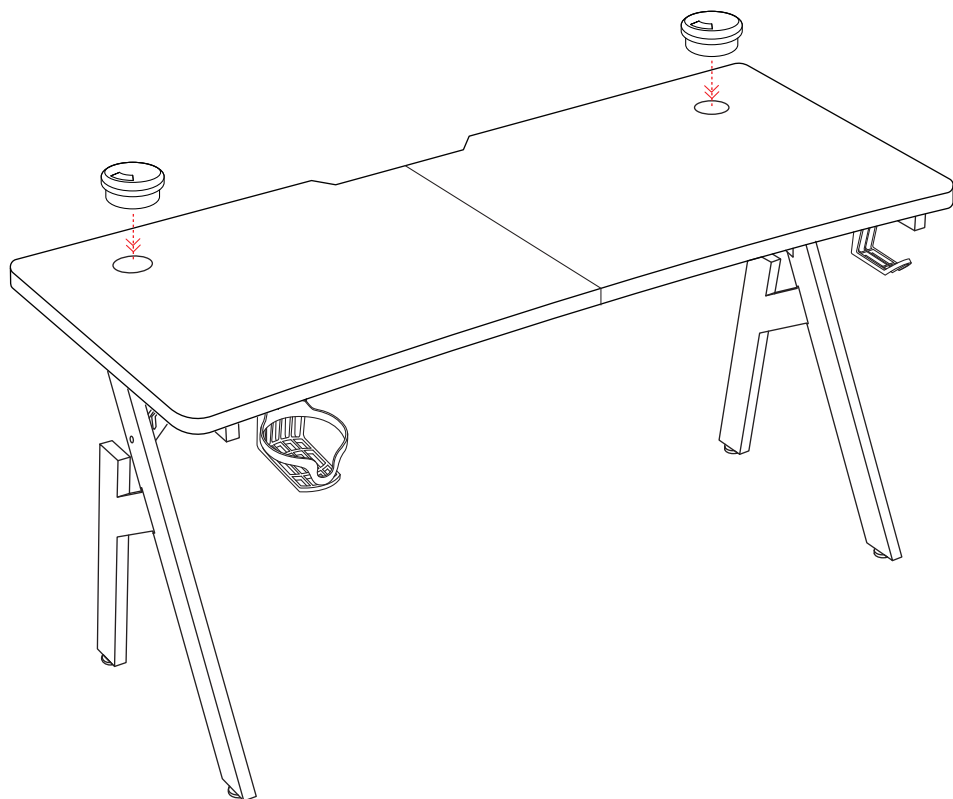
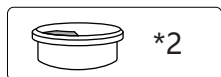

Fissa il gestione dei cavi ai piani del tavolo,
e il lavoro è completato.

Fixer les deux plateaux
de la table

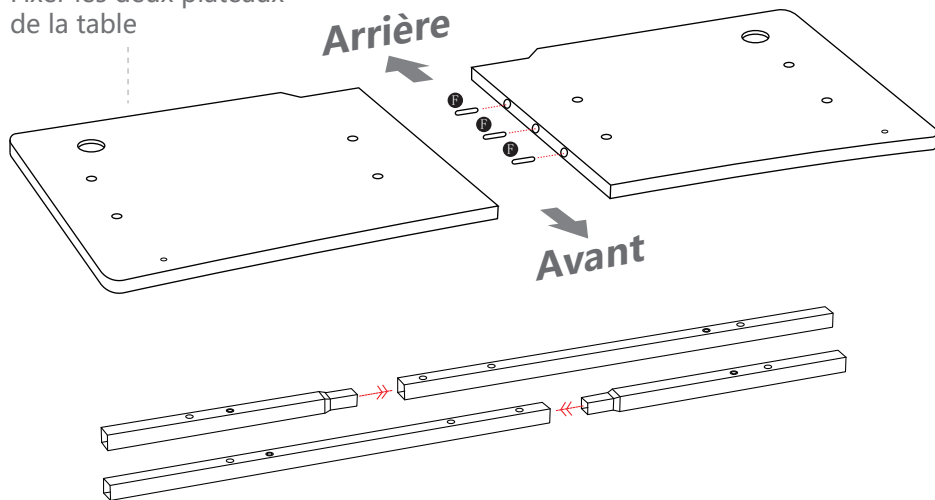

! Insérer la tige métallique courte dans la tige métallique longue.
Installer comme indiqué dans le diagramme.

C  30mm*8

 *8

Boulon (30mm)

Rondelle

Postérieure

Antérieure

Renforcer la tige métallique

Fixer la tige métallique aux
plateaux de la table

B  35mm*4

 *4

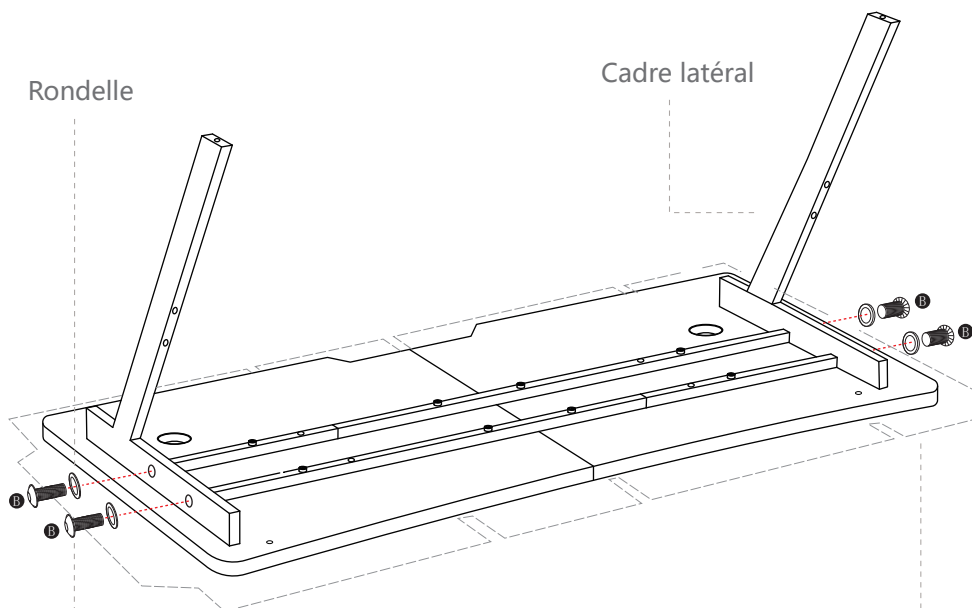

Rondelle

Cadre latéral

Boulon (35mm)

✳ Veuillez le laisser un peu lâche

Vous pouvez étaler le carton d'emballage sur le sol et l'utiliser comme tapis pour éviter que le plateau de la table n'entre en contact direct avec le sol et ne s'abîme.

ⓐ  30mm*2

ⓑ  12mm*2

 *4

 *2

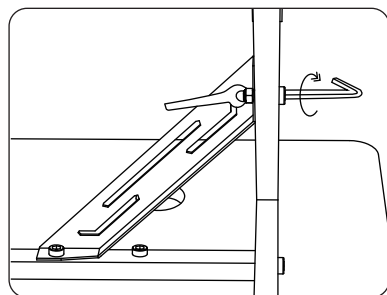
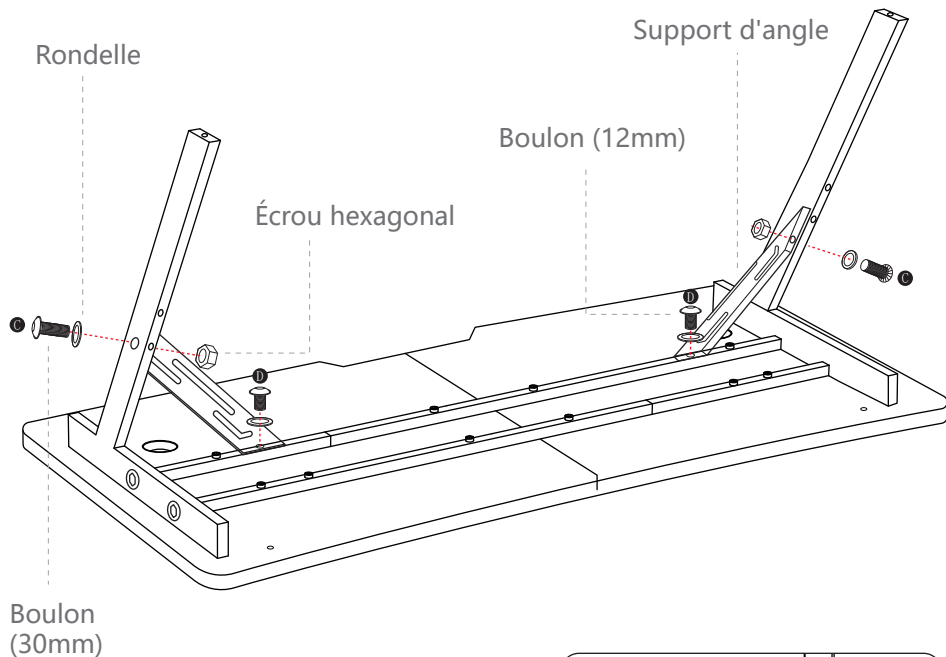

⚠ Veuillez ne pas serrer trop les vis pendant l'assemblage.
Faites particulièrement attention à ne pas serrer complètement toutes les vis tant qu'elles ne sont pas toutes en place.

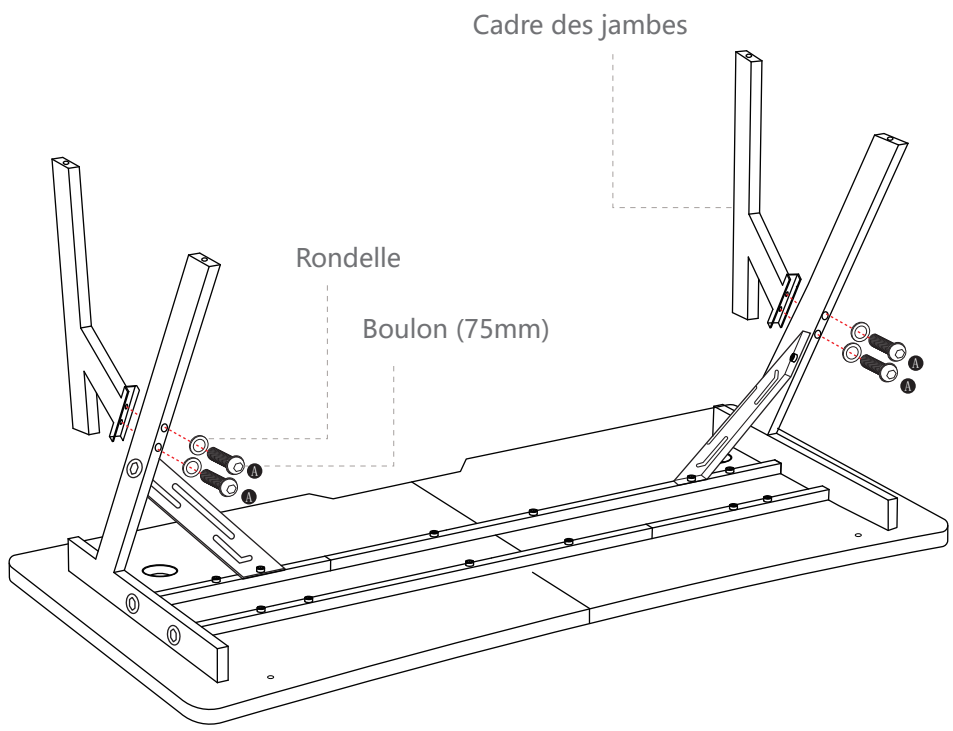
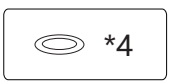

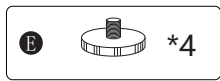

Pieds

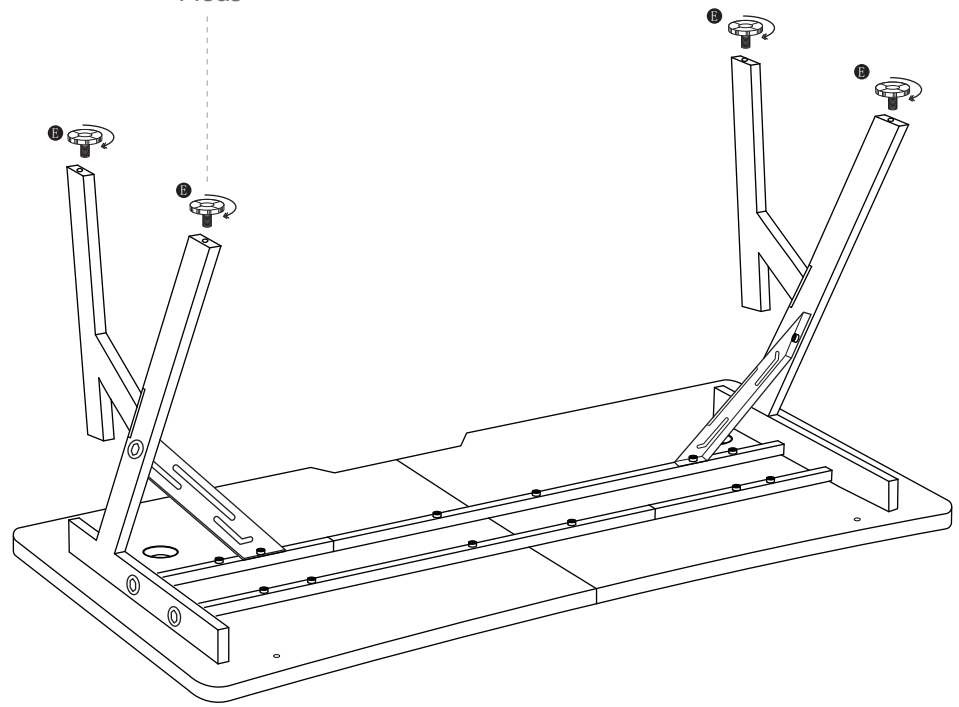

Installer les pieds.

① 12mm*2

*2

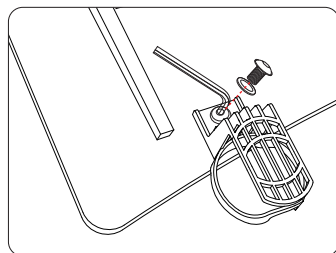
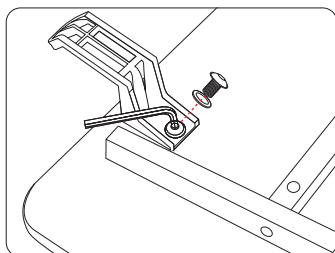
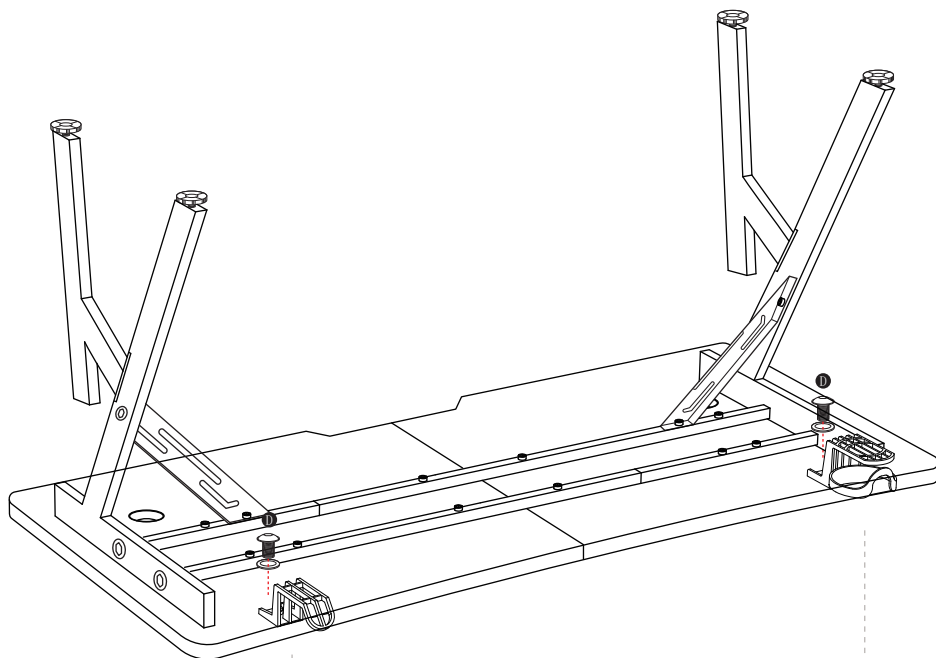
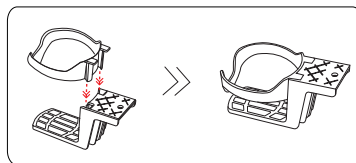

Installer le porte-gobelet et le crochet pour écouteurs.

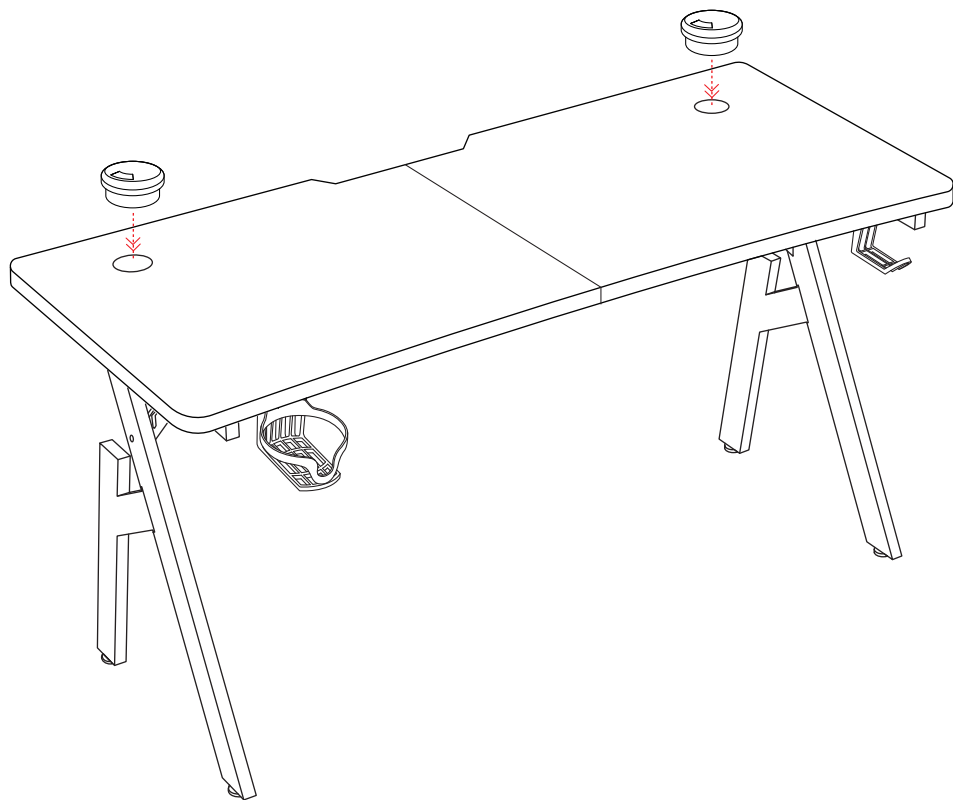
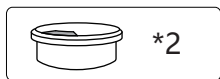

Fixez le passage de câbles au plateau, et c'est terminé.

Fijar las dos partes del tablero

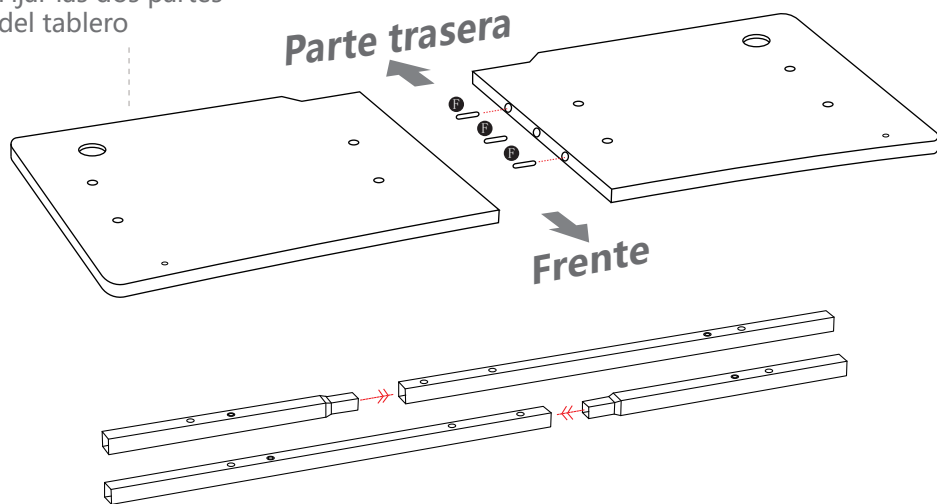

! Inserte la varilla más corta en la varilla más larga y móntelo como se muestra en la imagen.

C  30mm*8

 *8

Tornillo (30mm)

Arandela

Parte trasera

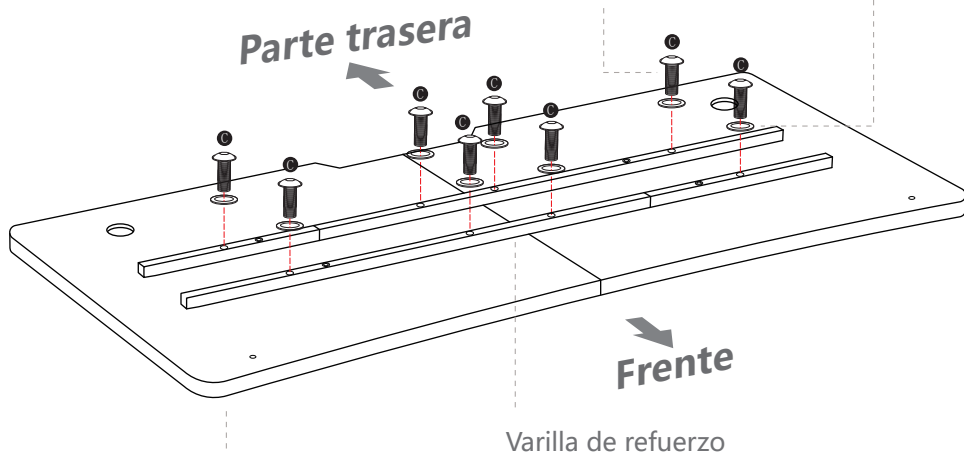

Fije el marco a la tabla utilizando los tornillos

B  35mm*4

 *4

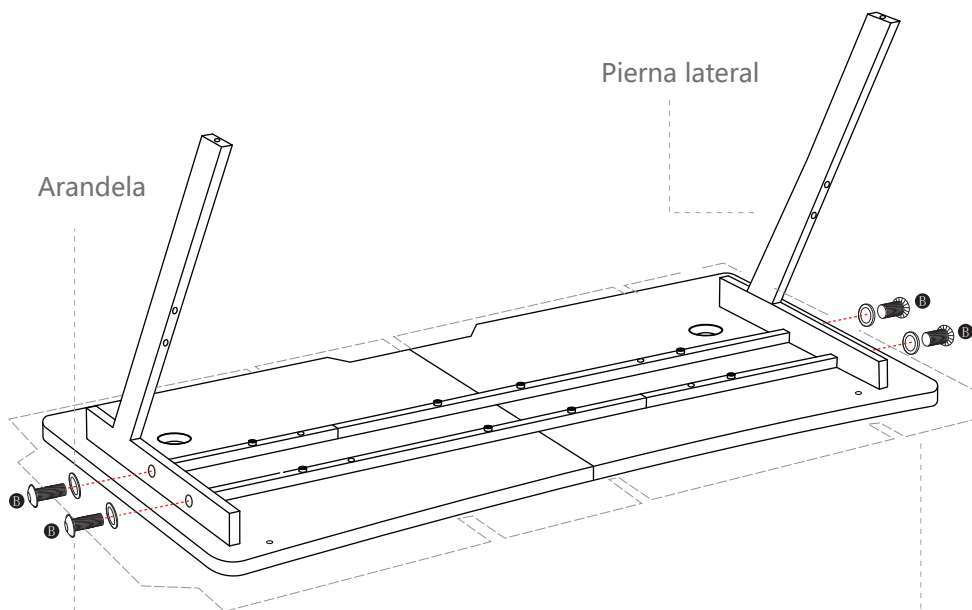

Tornillo (35mm)

✘ No lo apriete completamente por ahora

Puede extender la caja de embalaje en el suelo y usarla como acolchado para evitar que la superficie de la mesa entre en contacto directo con el suelo y se dañe.

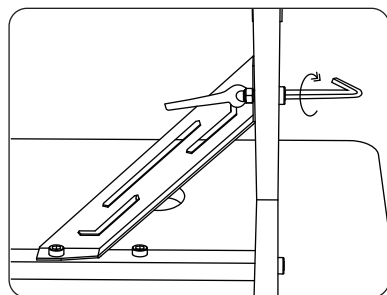
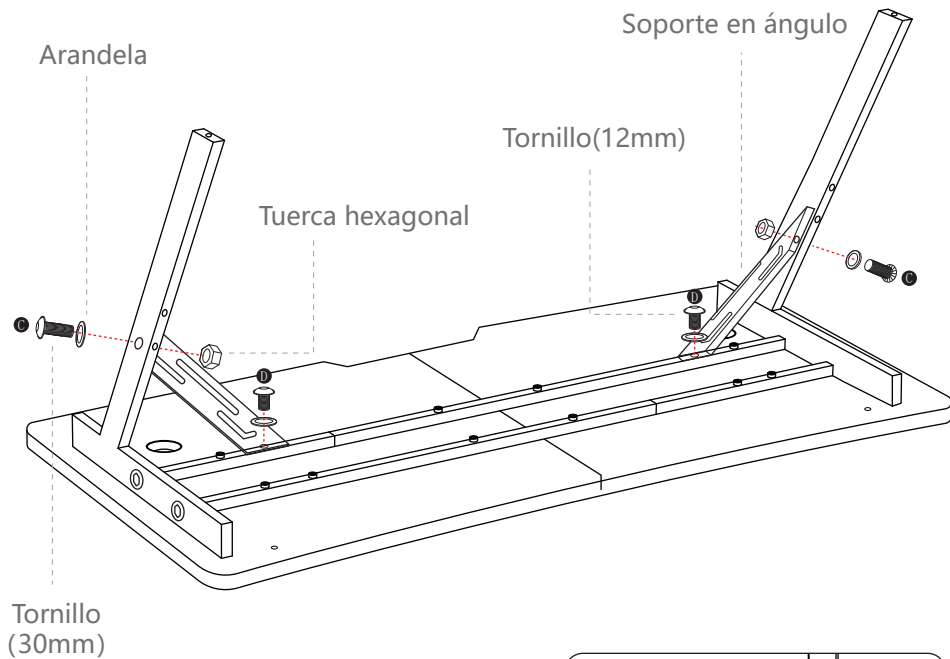

⚠ Por favor, tenga en cuenta que debe apretar cada tornillo solo después de haber fijado todos los tornillos.



75mm*4



*4

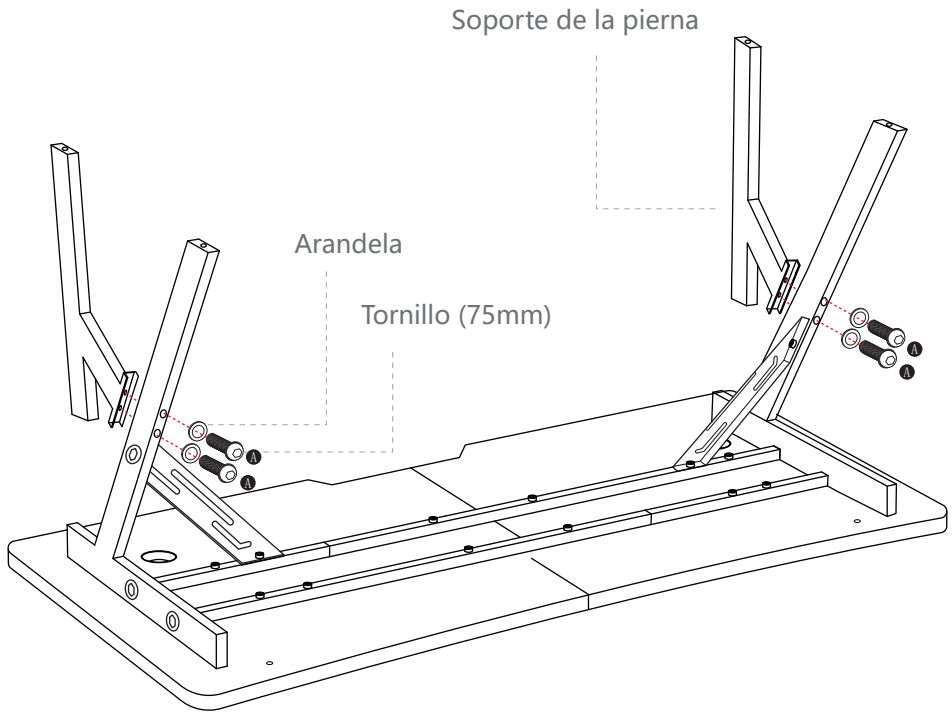

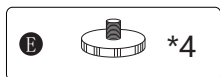

Tapón de pie regulable

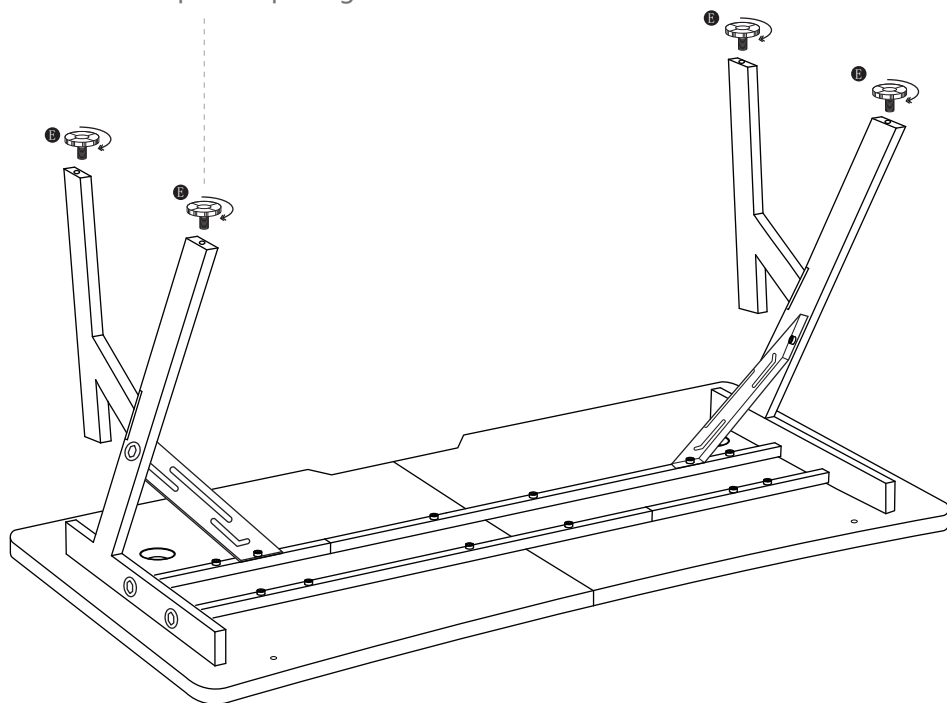

Instale el tapón de pie regulable.

① 12mm*2

*2

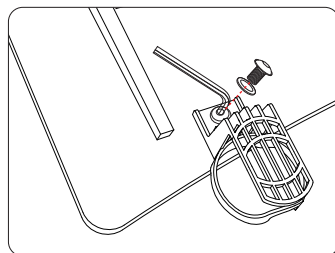
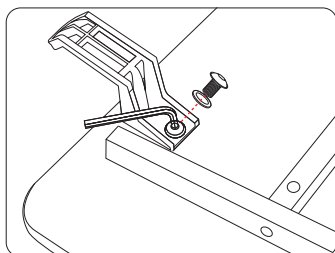
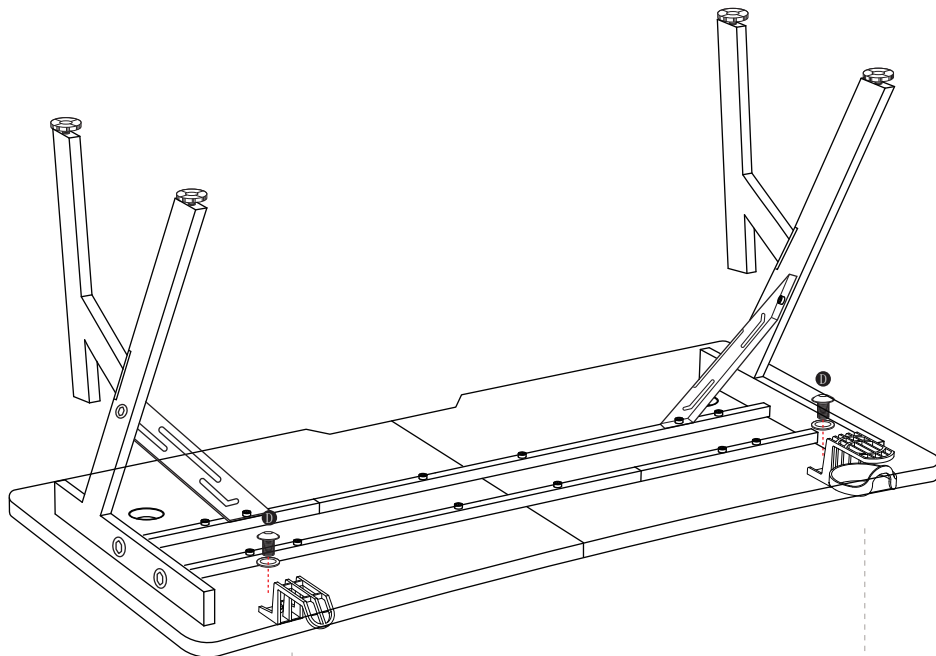
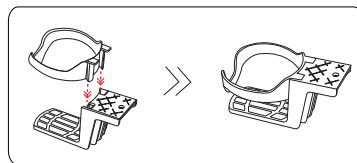

Instale el portavasos y el gancho para auriculares.

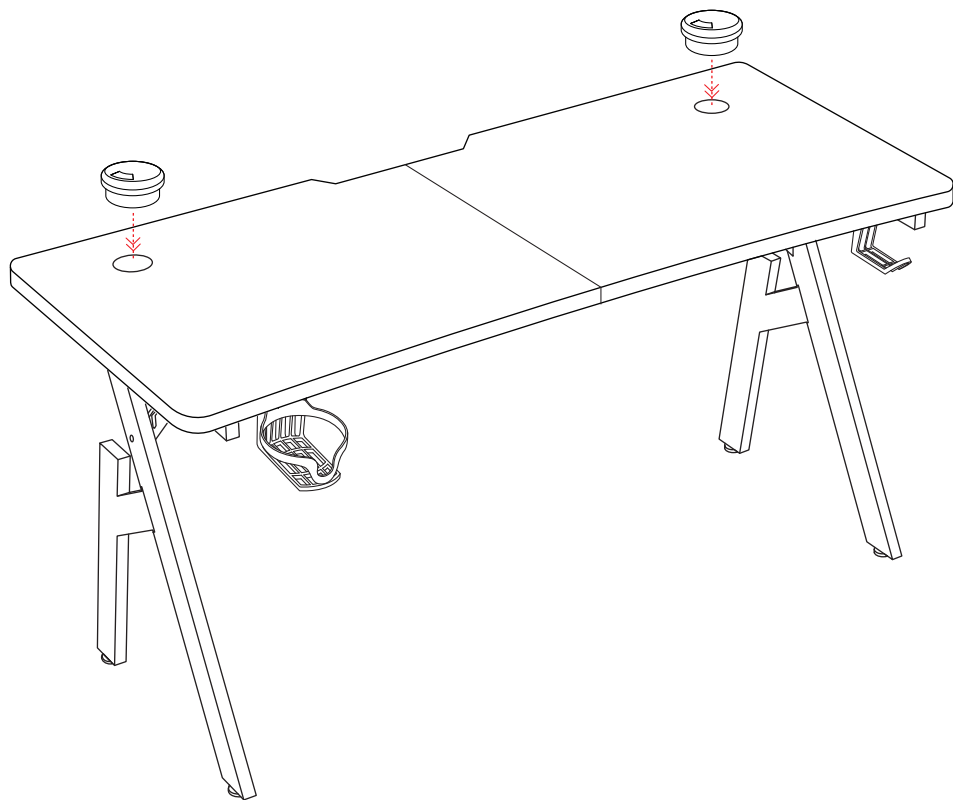
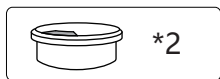

Instale la tapa del orificio de gestión de cables para completar el ensamblaje de la mesa.

Fäst de två bordsskivorna

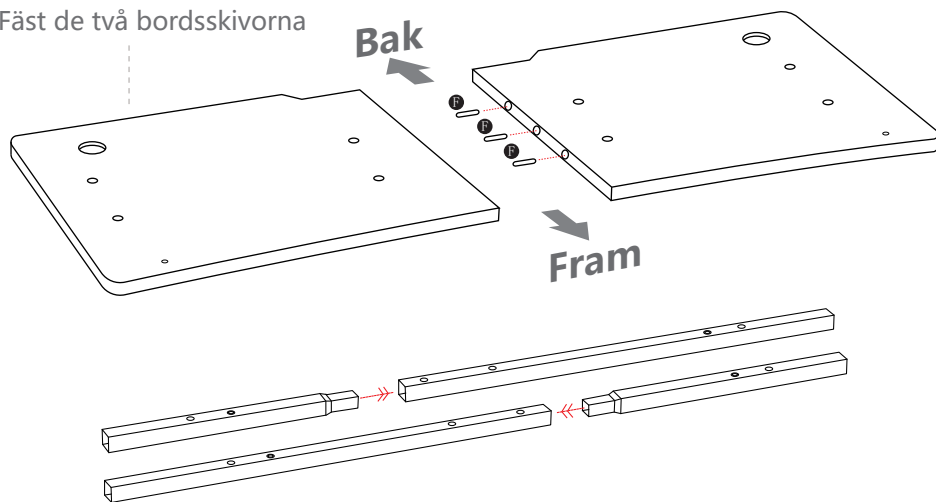

! Sätt in den korta metallstangen i den långa metallstangen som visas på bilden.

C  30mm*8

 *8

Bultar (30 mm)

Skivor

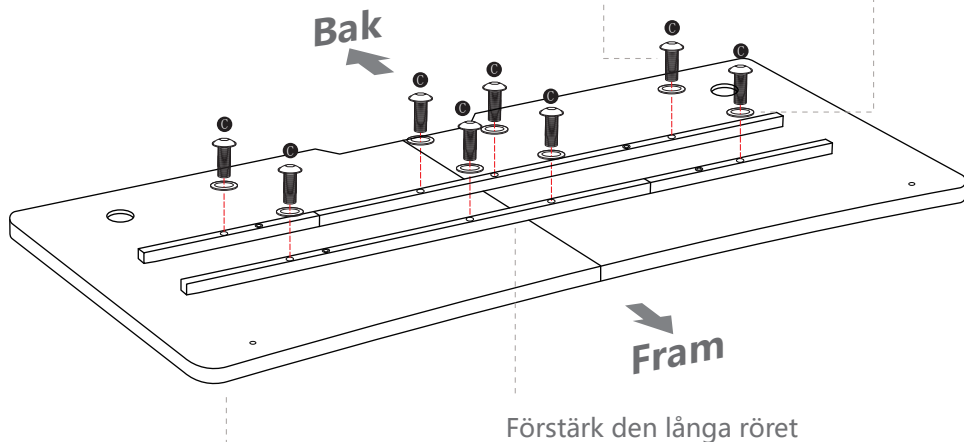

Fäst ramen på bordsskivan

Förstärk den långa röret

B  35mm*4

 *4

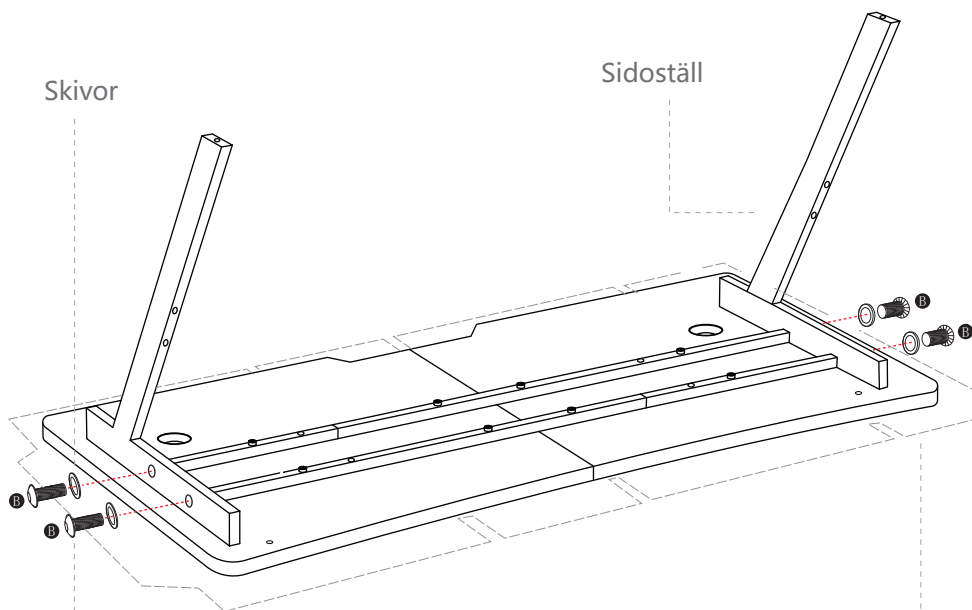

Skivor

Sidoställ

Bultar (35 mm)

※ Jag kommer att hålla det löst

Du kan lägga ut förpackningslådan på golvet och använda den som underlag för att förhindra att bordsskivan kommer i direkt kontakt med golvet och blir skadad.

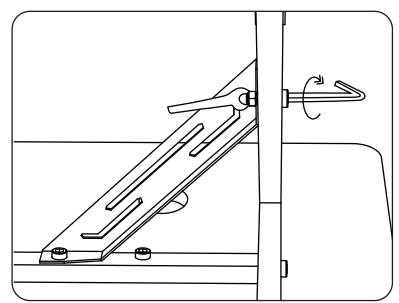
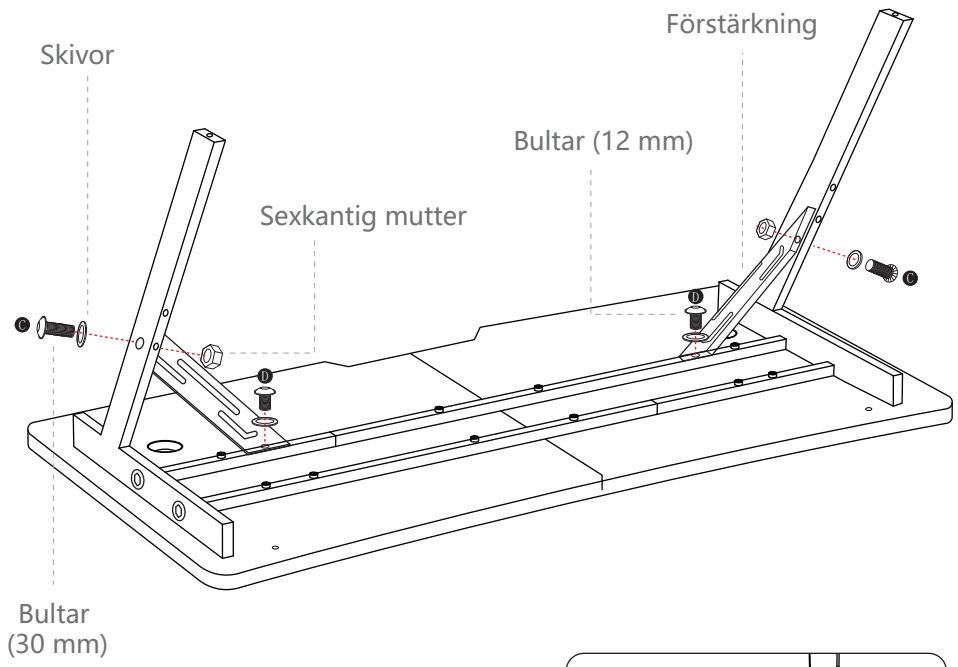
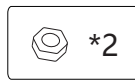
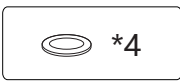

! Var noga med att inte dra åt skruvarna för hårt under monteringen. När alla skruvar är på plats, dra åt dem alla samtidigt.

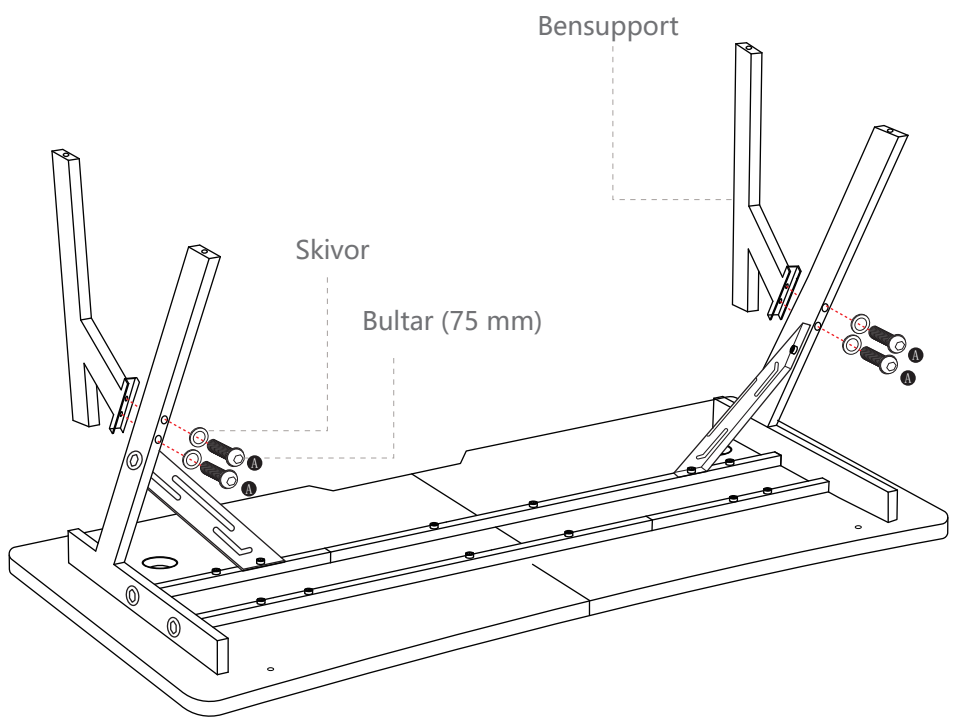
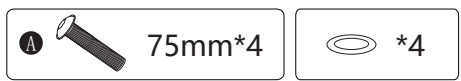

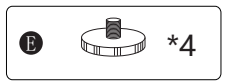

Fötter

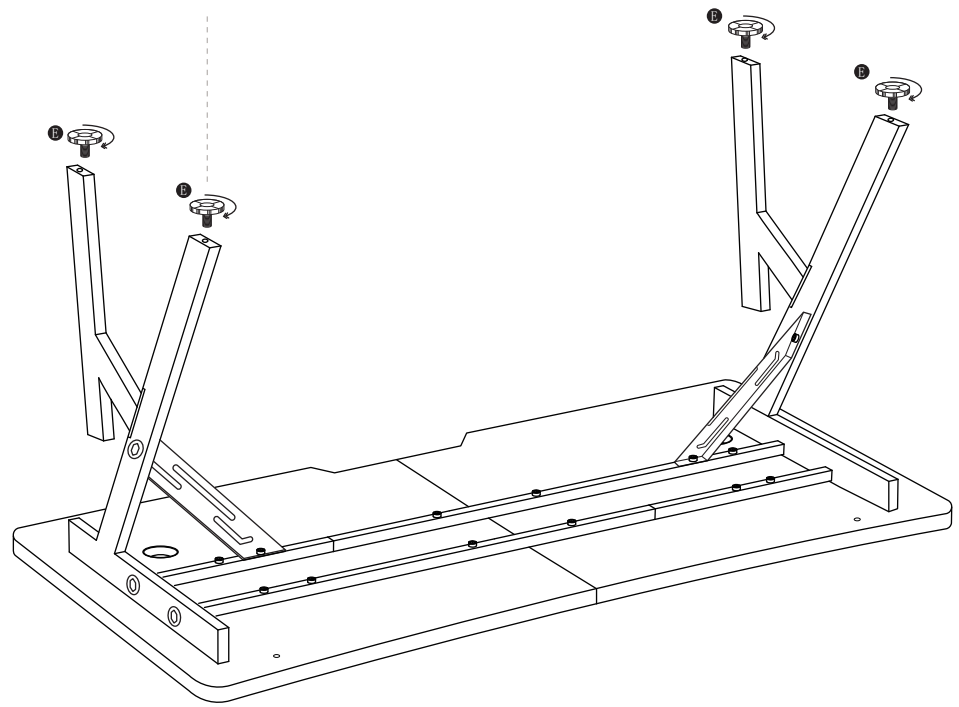

Installera fötter

① 12mm*2

*2

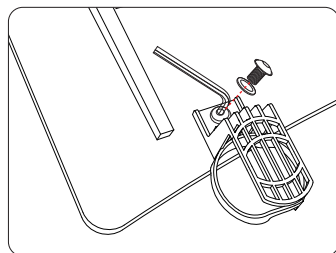
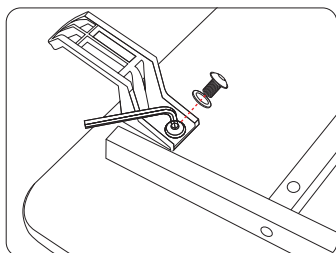
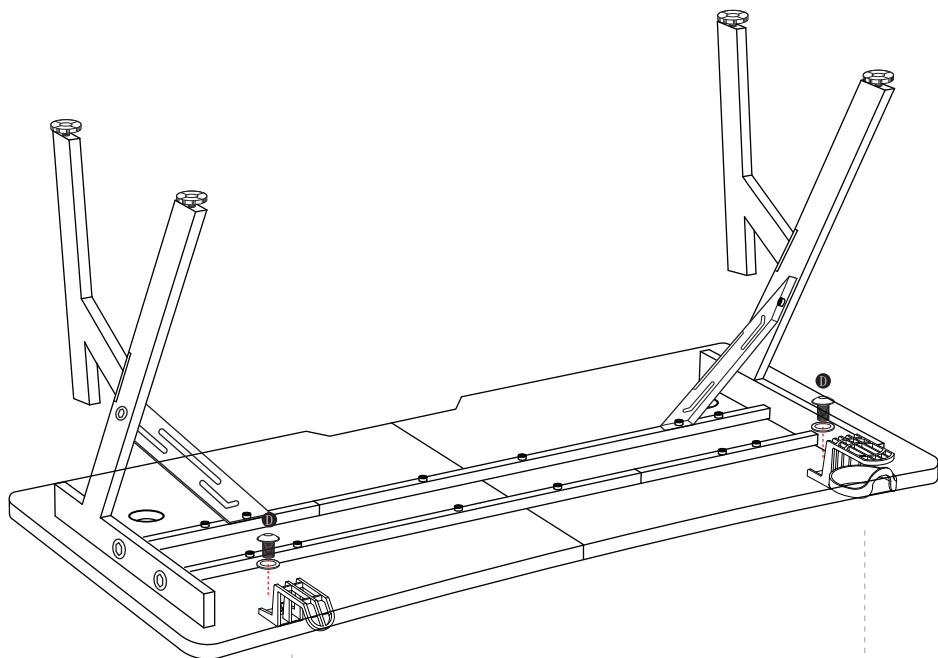
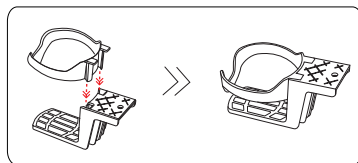

Installera kopphållare och hörlurskrok.

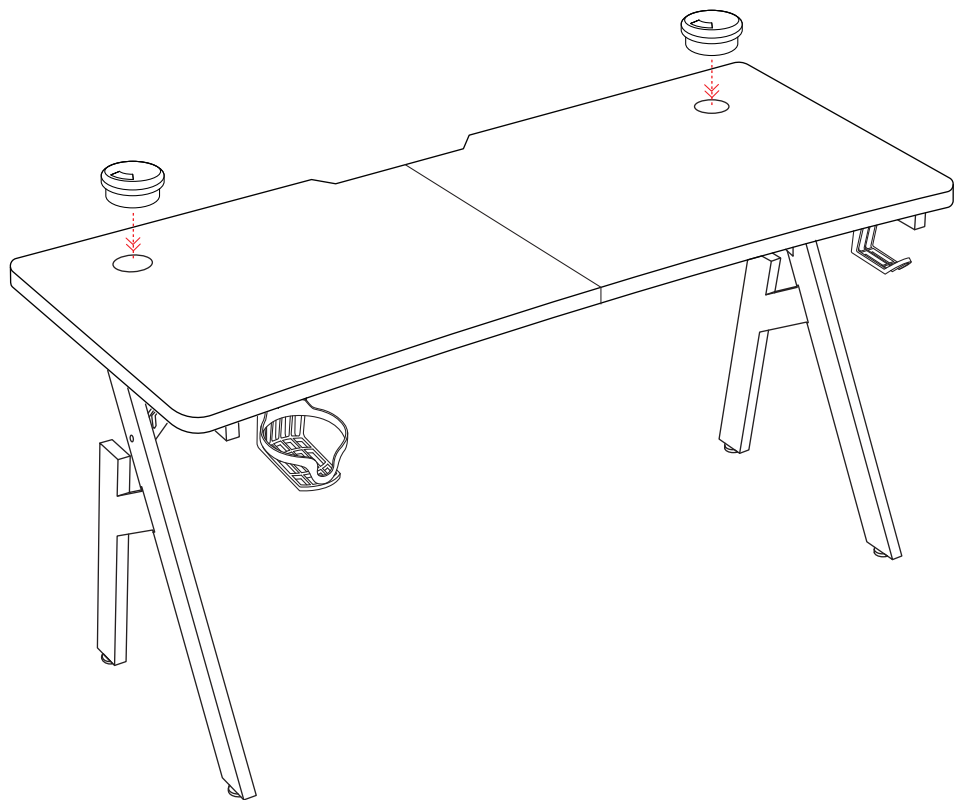
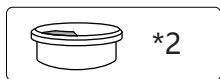

Installera kabelgenomföringslocket på bordsskivan och slutför installationen.

Bevestig de twee
tafelbladen

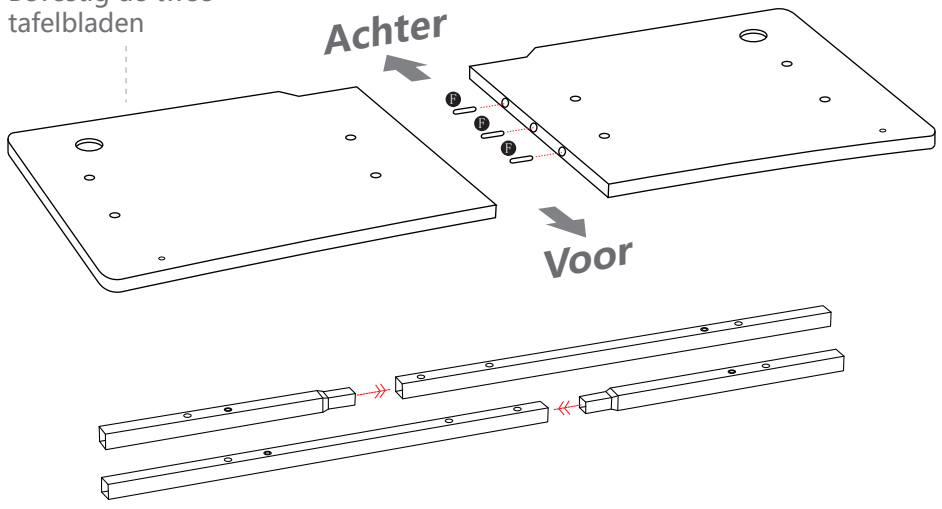

! Steek de korte metalen staaf in de lange metalen staaf zoals weergegeven in de afbeelding.

C  30mm*8

 *8

Bouten (30 mm)

Ringetjes

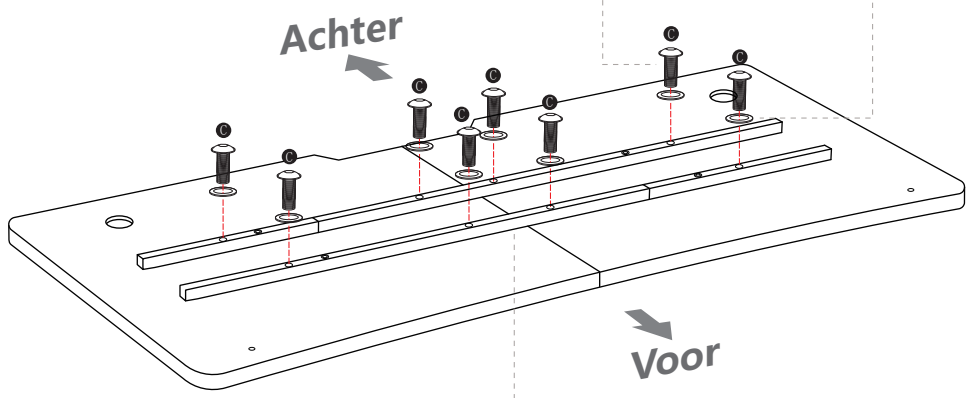

Bevestig het frame aan
het tafelblad

Versterk het lange pijp

B  35mm*4

 *4

Ringetjes

Zijstand

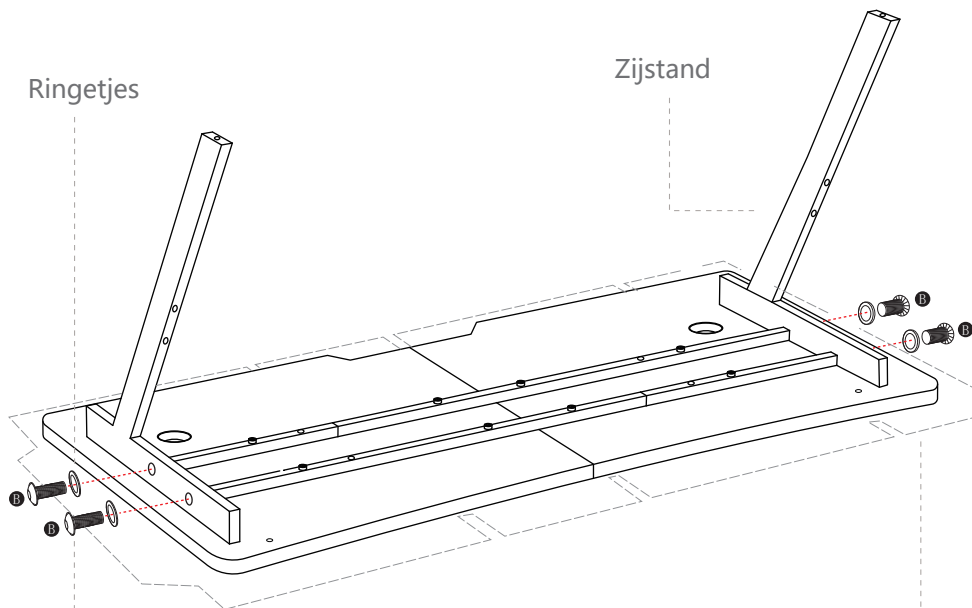

Bouten (35 mm)

※ Ik houd het los

U kunt de verpakingsdoos plat op de vloer leggen en als onderlegger gebruiken om te voorkomen dat het tafelblad direct in contact komt met de vloer en beschadigd raakt.

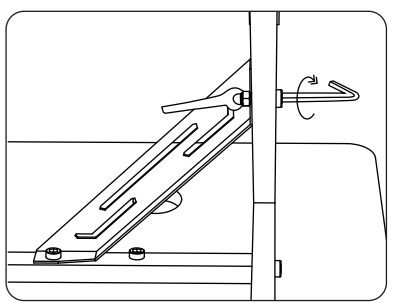
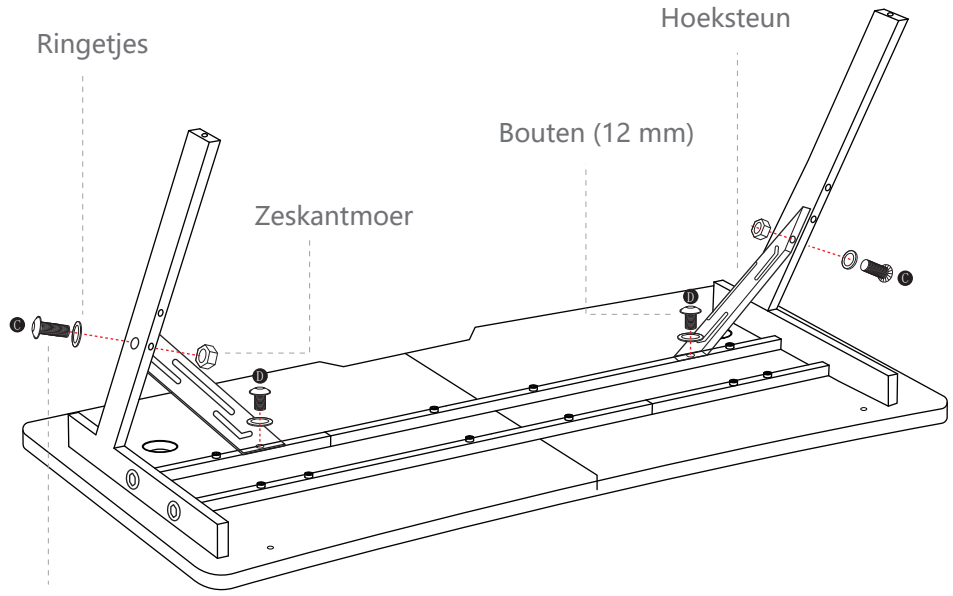
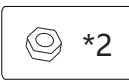
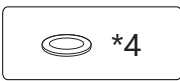

⚠ Wees er alstublieft voorzichtig mee om de schroeven tijdens het monteren niet te strak aan te draaien. Wanneer alle schroeven op hun plaats zitten, draai ze dan allemaal tegelijk aan.

A



75mm*4



*4

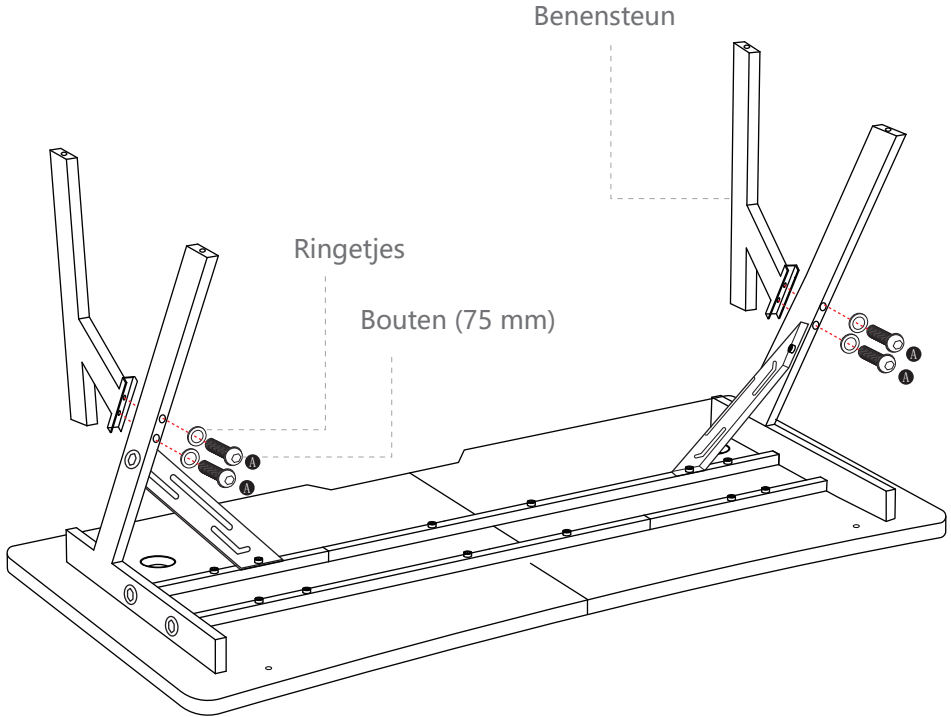

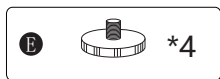

Voetjes

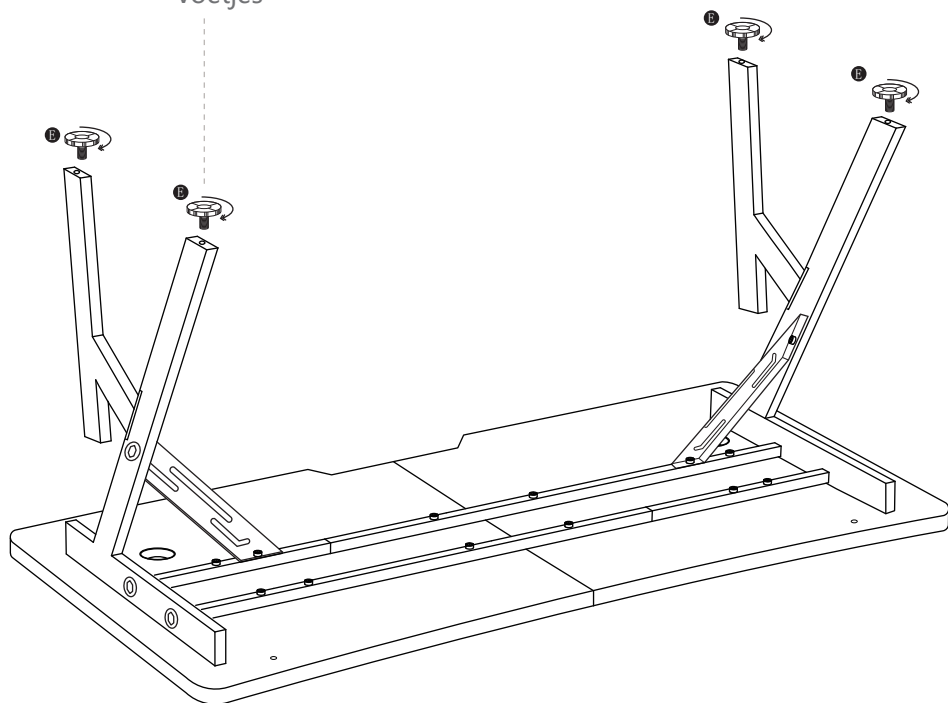

Voetjes installeren

①  12mm*2

 *2

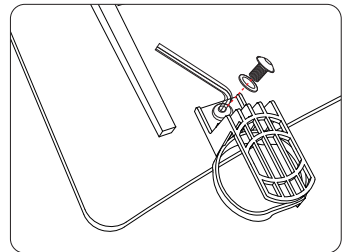
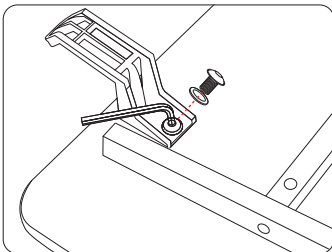
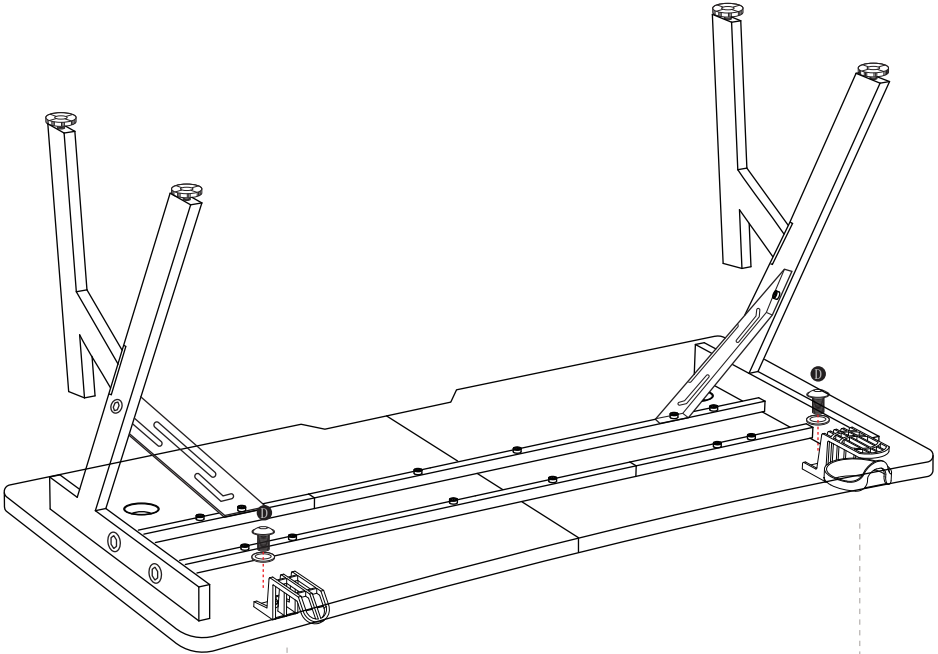
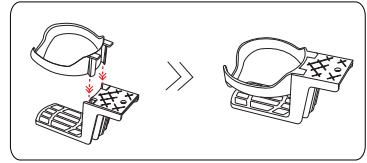

Installeer bekerhouder en hoofdtelefoonhaak.

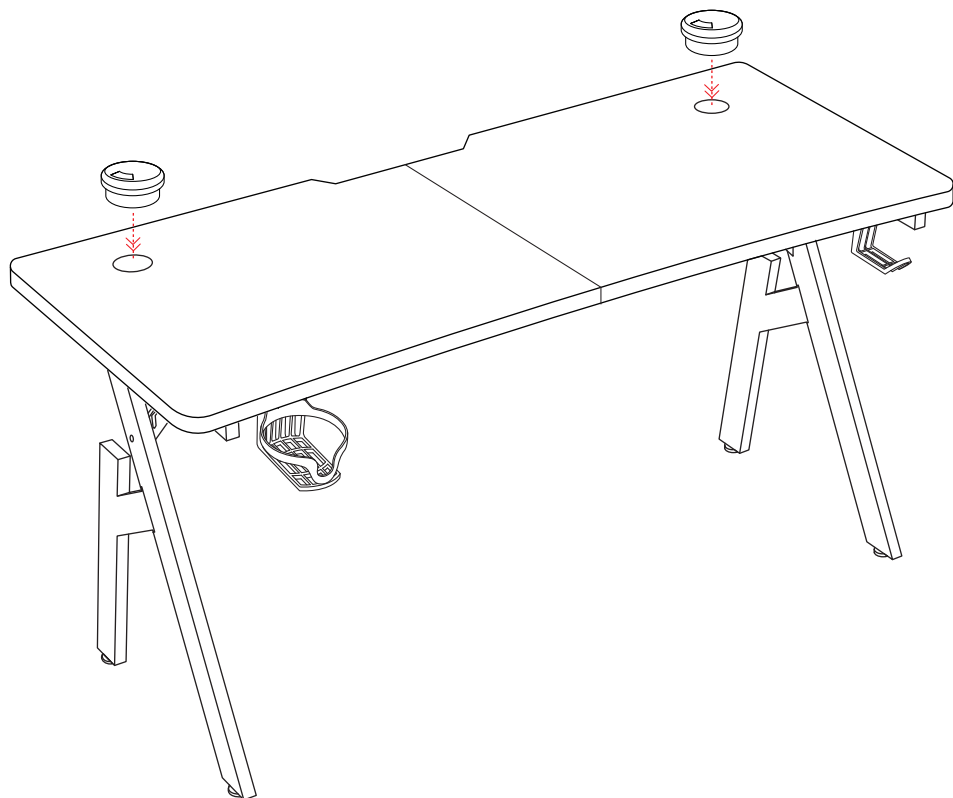
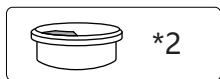

Installeer de kabeldoorvoertule op het tafelblad en voltooi de installatie.

2枚の天板を固定する

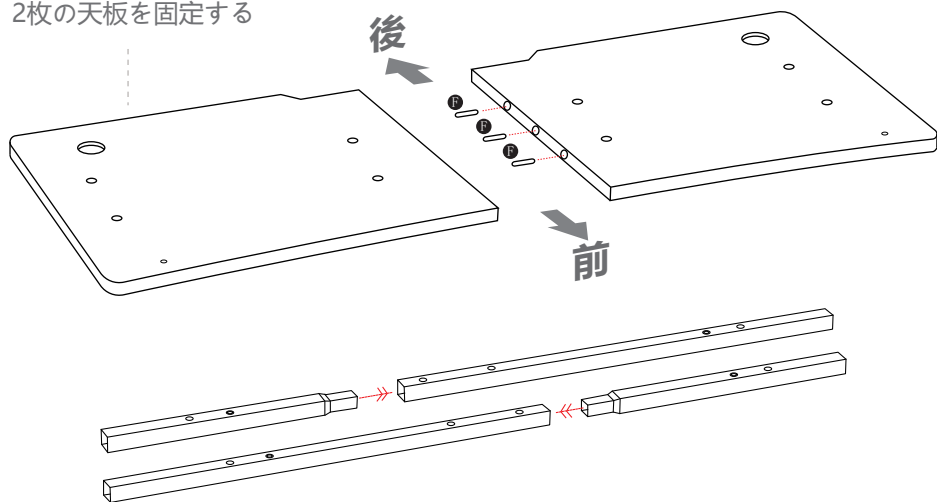

⚠ 長いリーンフォースメントに短いリーンフォースメントを差し込みます。図のように取り付けてください。

● 30mm*8

○ *8

ボルト (30mm)

ワッシャー

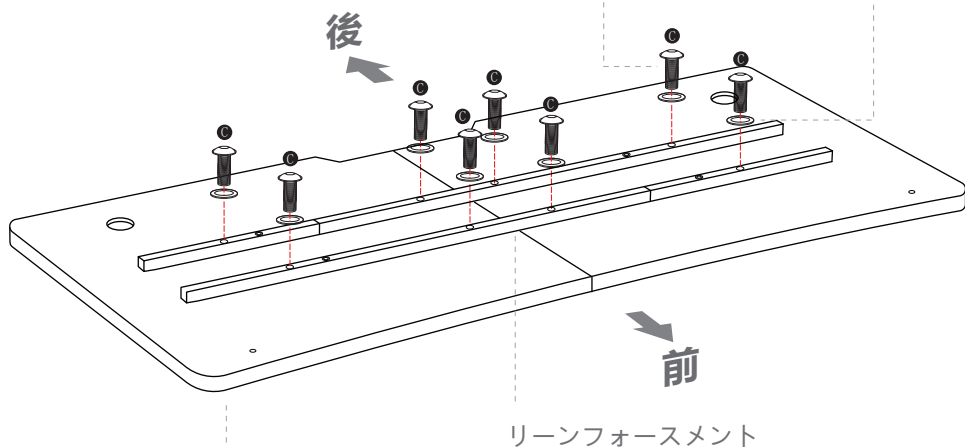

天板にフレームを取り付けます

Ⓑ  35mm*4

 *4

ワッシャー

サイドフレーム

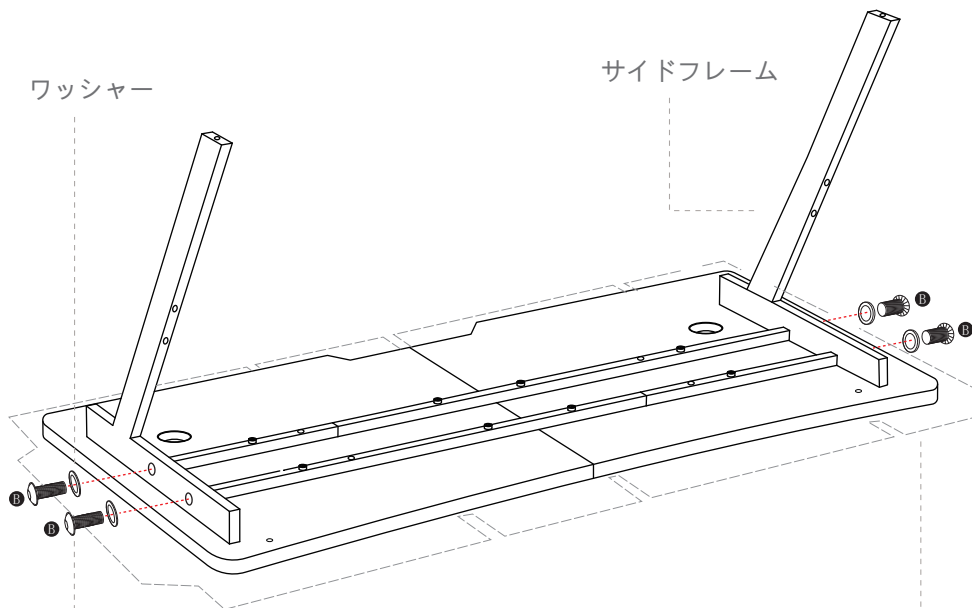

ボルト (35mm)

※ ゆるめに付けておきます

梱包用の箱を床に平らに置いてマットとして使用することで、テーブルの表面が床と直接接触して摩耗するのを防ぐことができます。

① 30mm*2

② 12mm*2

*4

*2

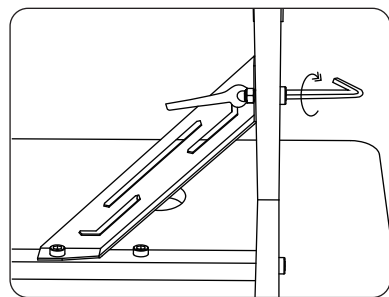
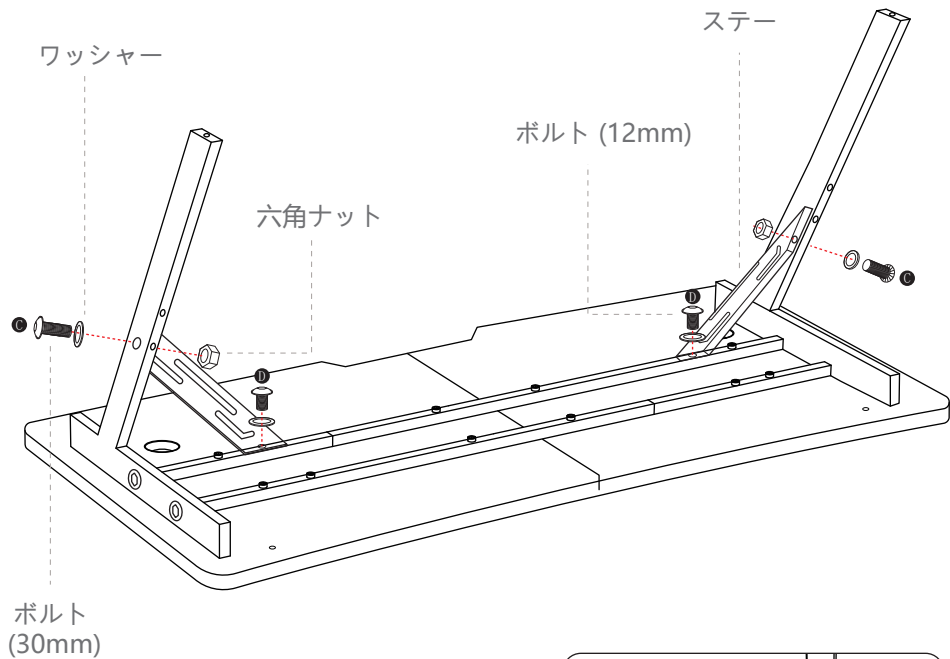

! 組立中ネジはあまりきつく締めないでください。特に注意して、全部のネジを入れるまで、しっかり締めないでください。

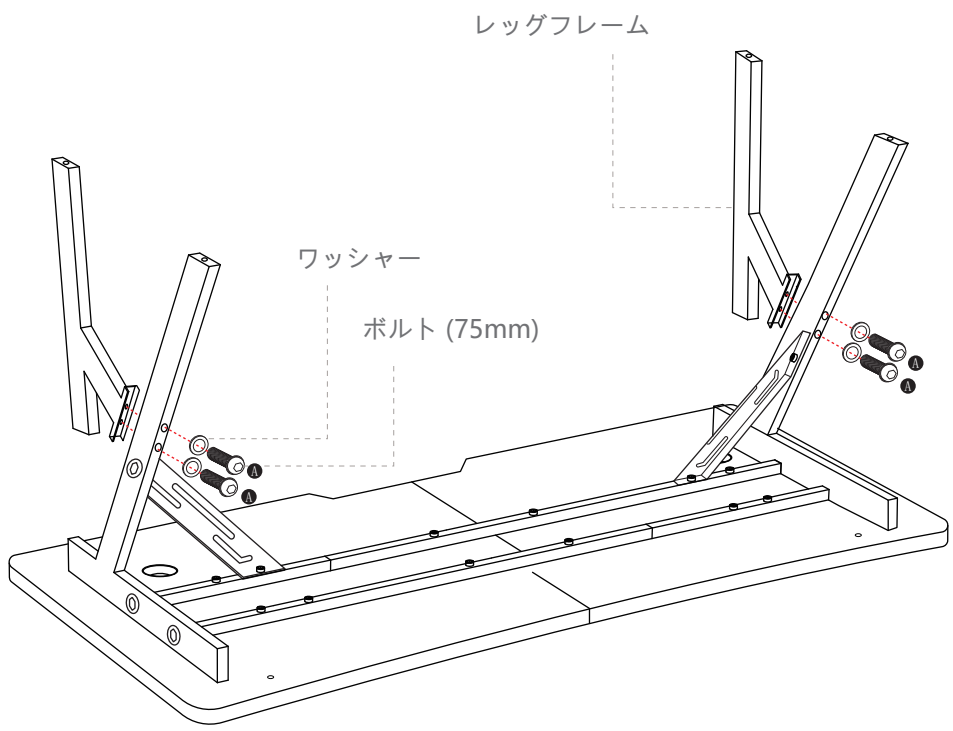
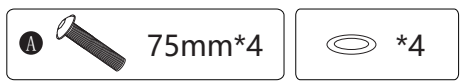

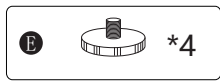

アジャスター

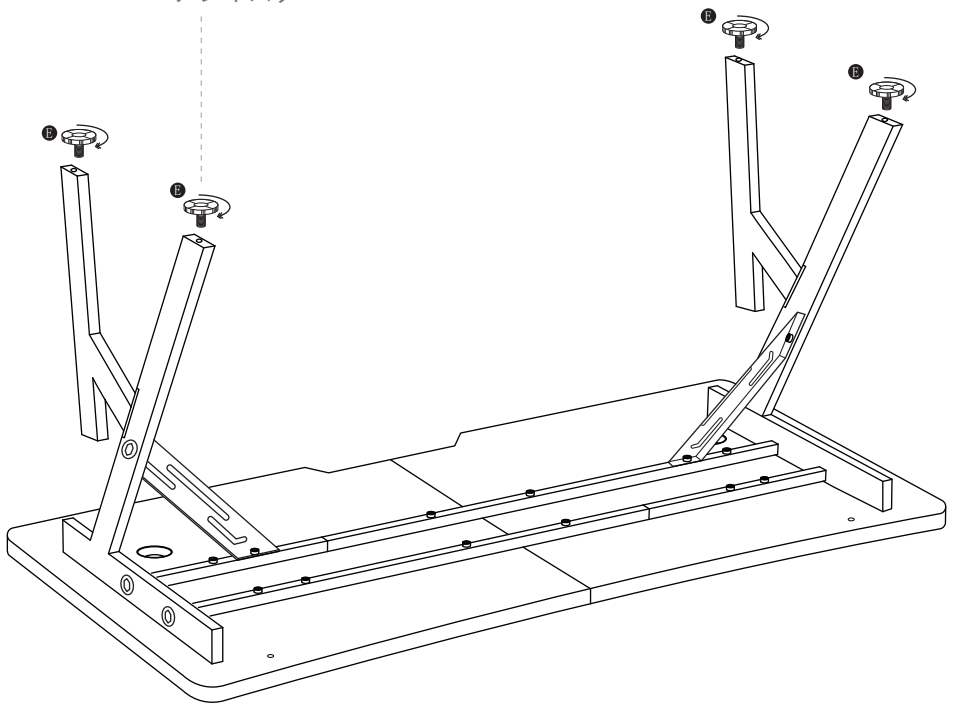

アジャスターを取付けます。

①  12mm*2

 *2

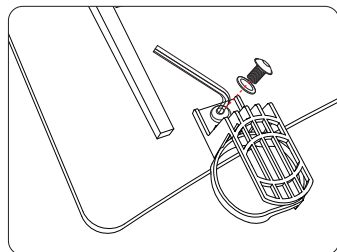
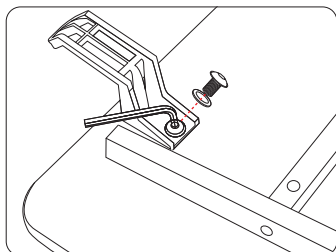
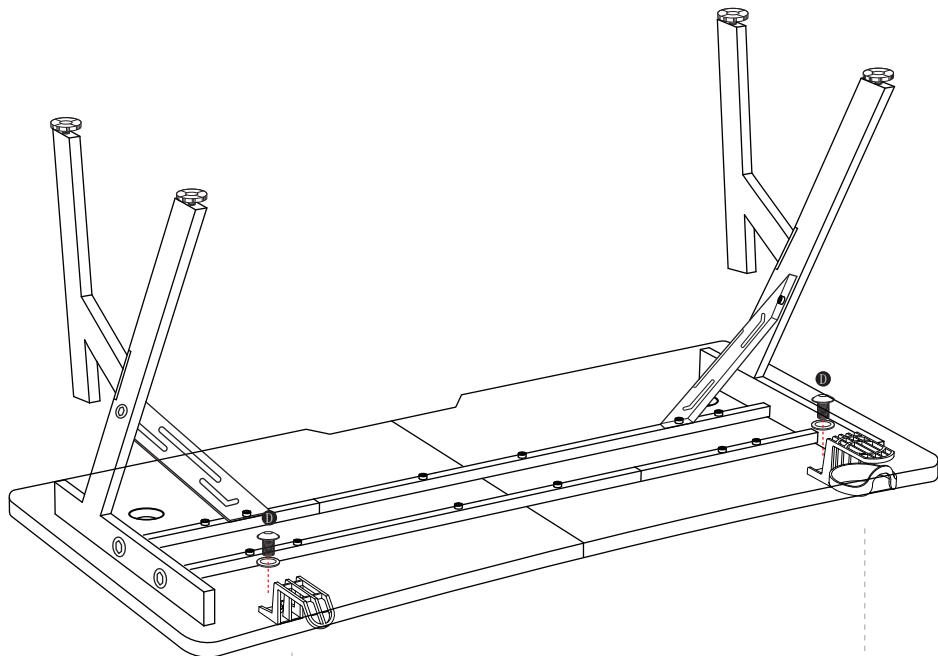
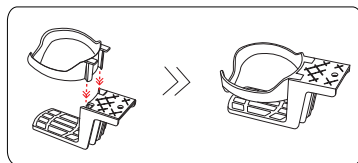

カップホルダーとイヤホンフックを取り付けます。

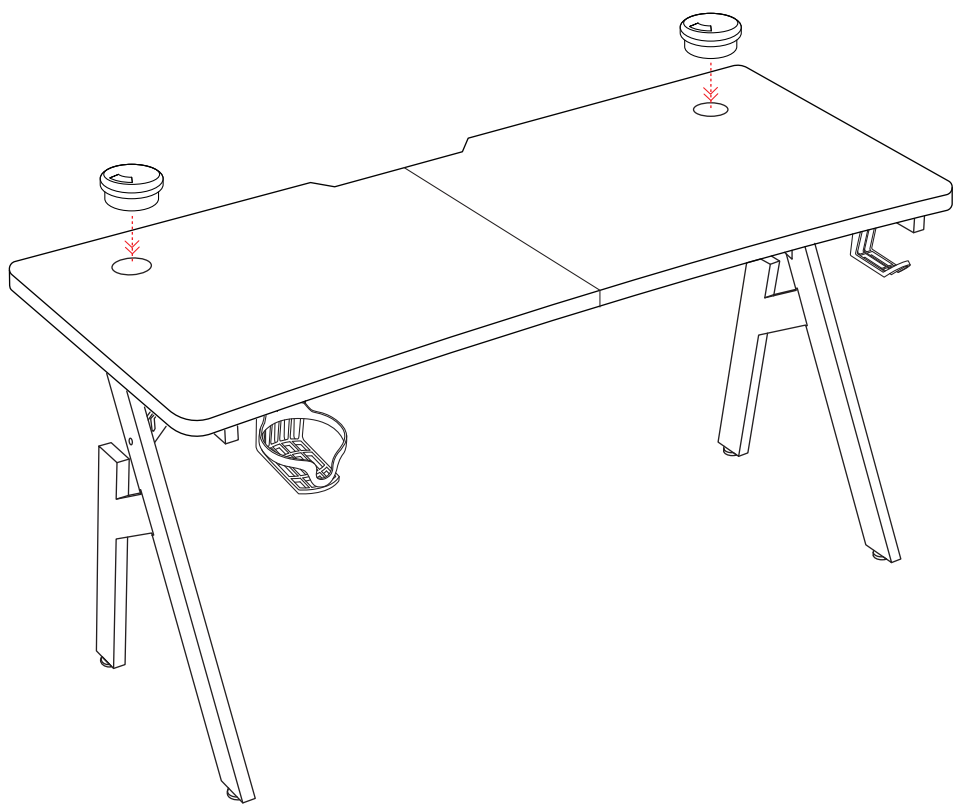

天板に配線孔キャップを取付けて完成です。