

Components and Hardware List

M5/16" X 1/2"
Allen Head Bolt

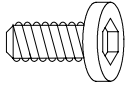

A 12 pcs.

5/16" Spring
Washer



B 12 pcs.

5/16" x 18mm
Flat Washer



C 12 pcs.

5mm Allen
Wrench



D 1 pc.

M5/16" X 1/2"
Flat Head Bolt

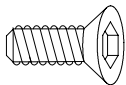

E 6 pcs.

Top



F 1 pc.

Bottom Shelf



G 1 pc.

Leg



H 6 pcs.

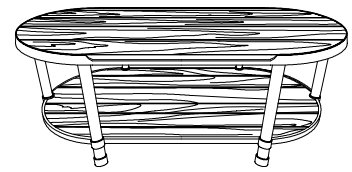

39502
Rectangular Cocktail Table

Be sure to check all packing material carefully for small parts, which may have come loose inside the carton during shipment.

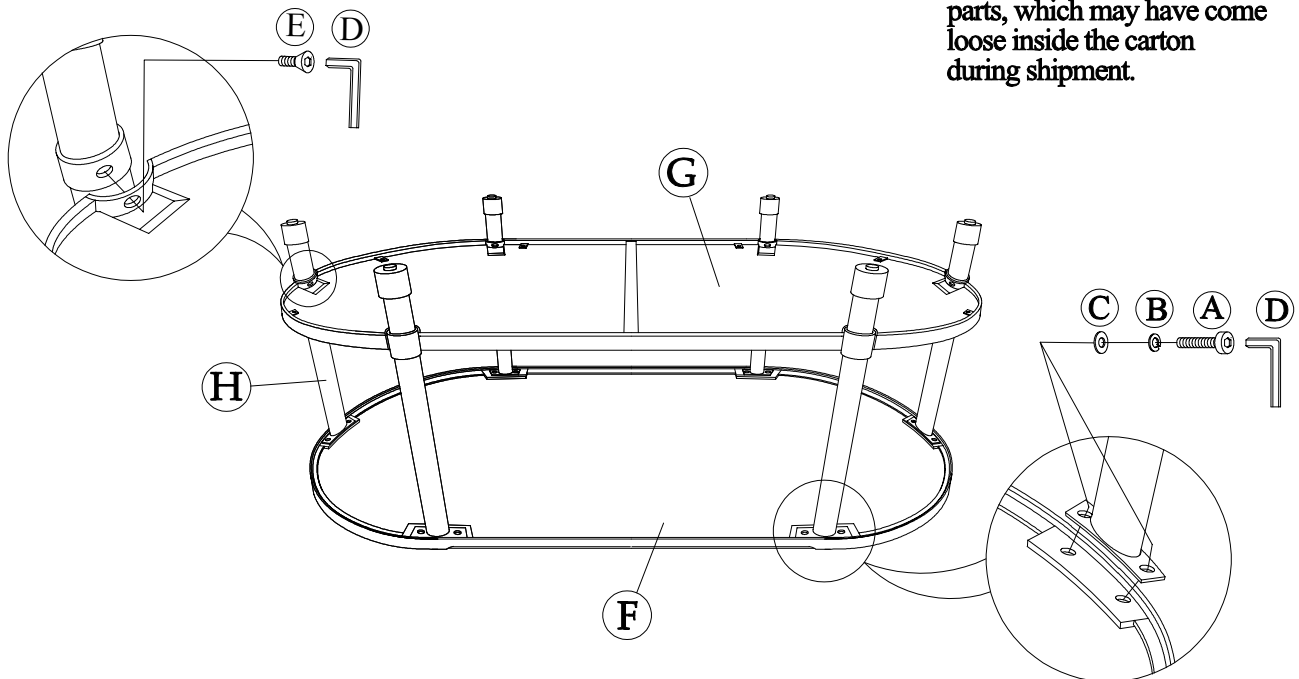

Note:

1. Do not discard any packing materials until the table has been completely assembled, to prevent parts from being accidentally discarded. To prevent possible scratches or damages, assemble the table on a soft surface such as a blanket or carpet, or it's own packaging materials.
2. Place two Legs (H) on the soft surface and attach the Bottom Shelf (G) to the Legs using the Flat Head Bolts (E), with the bottom of the shelf towards the bottom of the legs. Do not fully tighten bolts until after Step 4. Attach the other four Legs to the edges of the shelf as before but do not fully tighten bolts.
3. Place the Table Top (F) face down on the soft surface. Carefully place the assembled Legs & Shelf in position on the bottom side of the Table Top.
4. Attach the top of the Legs to the Table Top using the Flat Washers (C), Spring Washers (B) and Allen Head Bolts (A).
5. Using the Allen Wrench, tighten the Flat Head Bolts attaching the Legs and Shelf first, then tighten the Bolts attaching the top of the Legs to the Table Top last.
6. Carefully turn the assembled table upright.
7. Levelers are installed into the bottom of the legs and can be used to compensate for uneven flooring if necessary.