

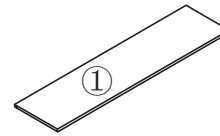

# Board Identification

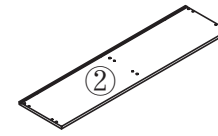

Board x1



Bottom board x1

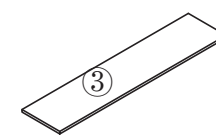

Large layer board x1

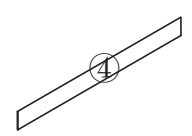

Back board x1

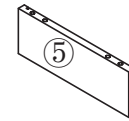

Left side board x1

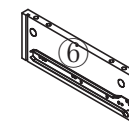

Right side board x1

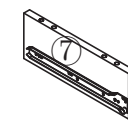

vertical board x1

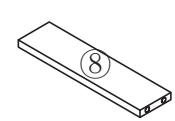

Reinforcement board x2

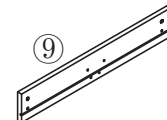

Left Drawer panel x1

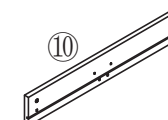

Right Drawer panel x1

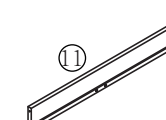

Back Drawer x2

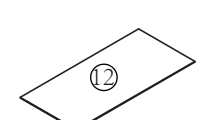

Bottom Drawer x2

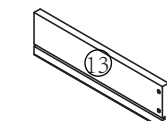

Drawer side panel left x2

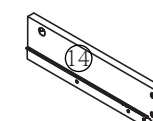

Drawer side panel right x2

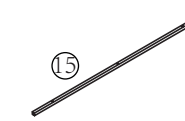

Pipe x2

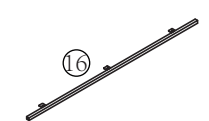

Pipe x2

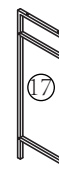

Legex2

# Board Identification

Not actual size

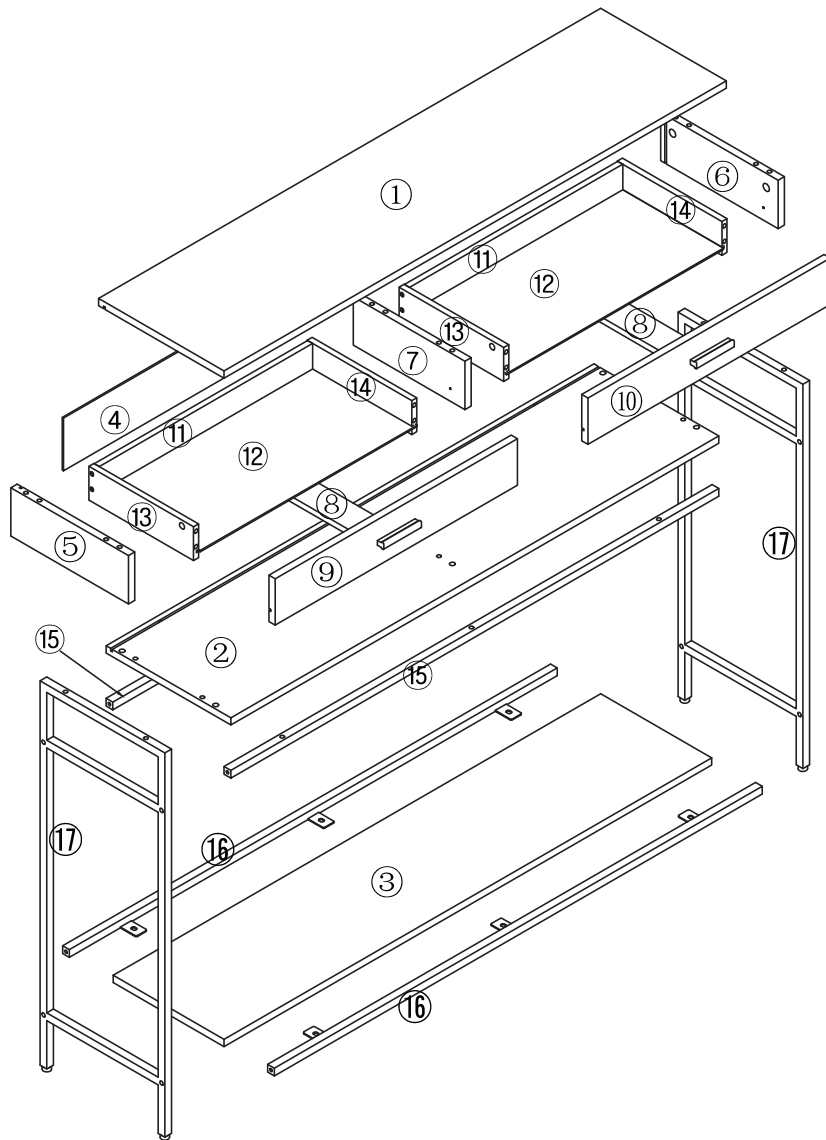

# Hardware List

Actual size

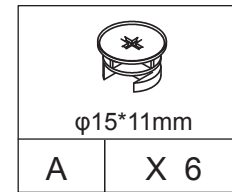

CAM LOCK

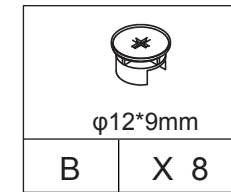

CAM LOCK

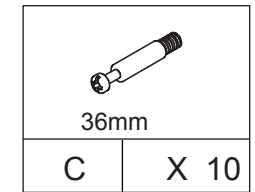

CAM BOLT

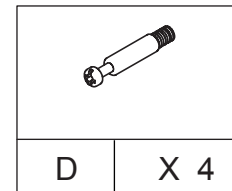

CAM BOLT

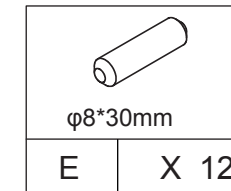

WOOD DOWEL

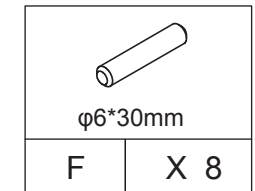

WOOD DOWEL

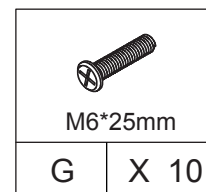

SCREW

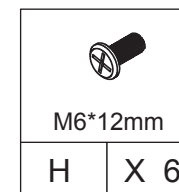

SCREW

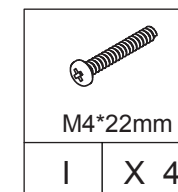

SCREW

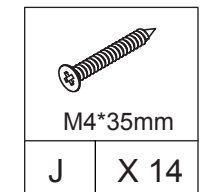

SCREW

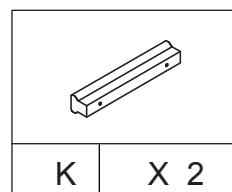

HANDLE

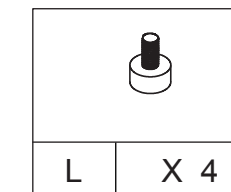

ADJUSTING FOOT

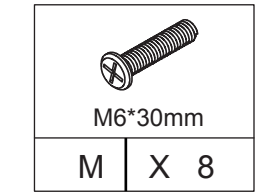

SCREW

PRODUCT ASSEMBLY

STEP 1

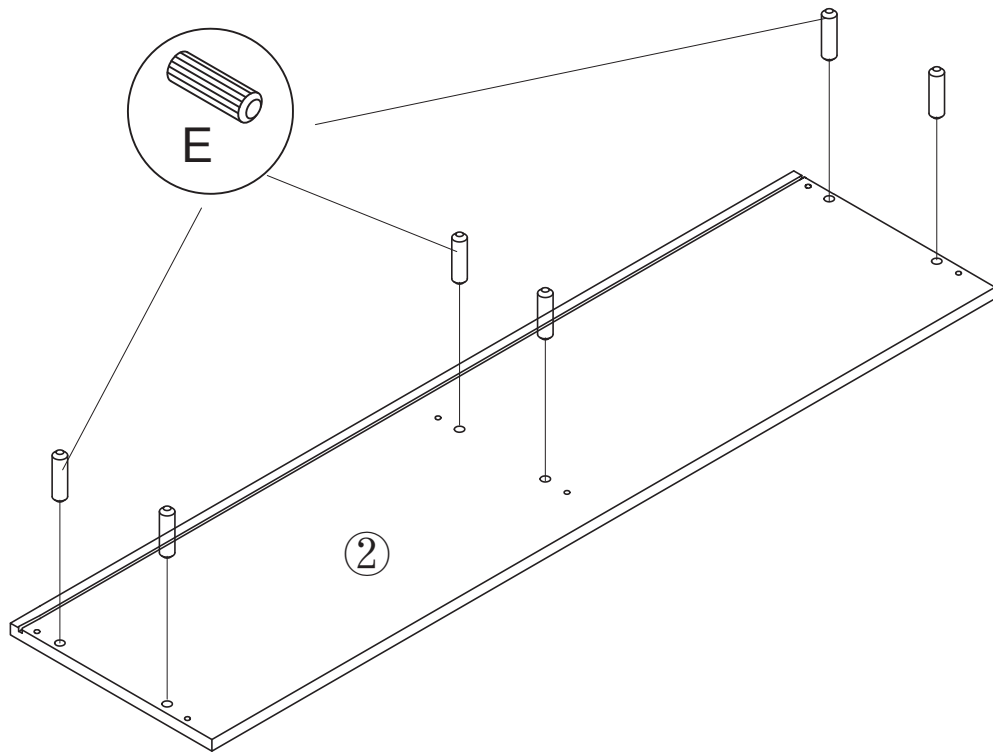
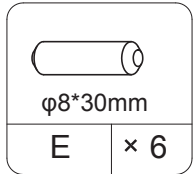

5

PRODUCT ASSEMBLY

STEP 2

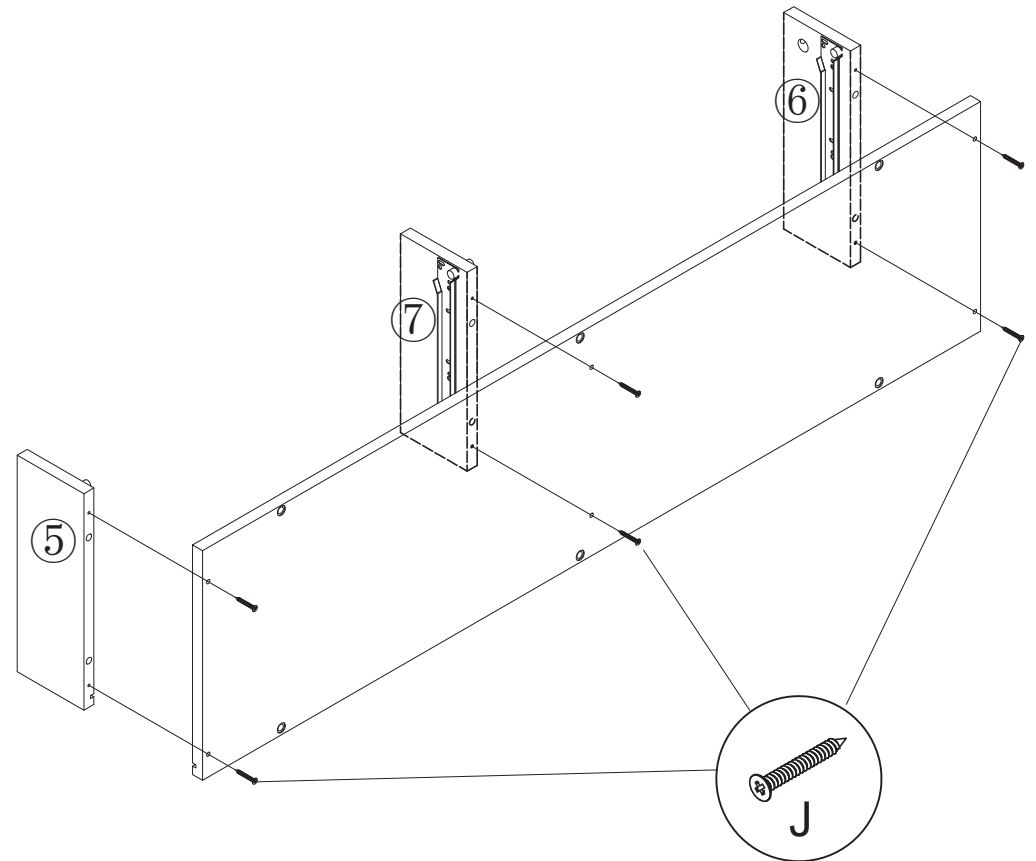
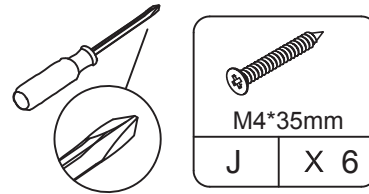

6

PRODUCT ASSEMBLY

STEP 3

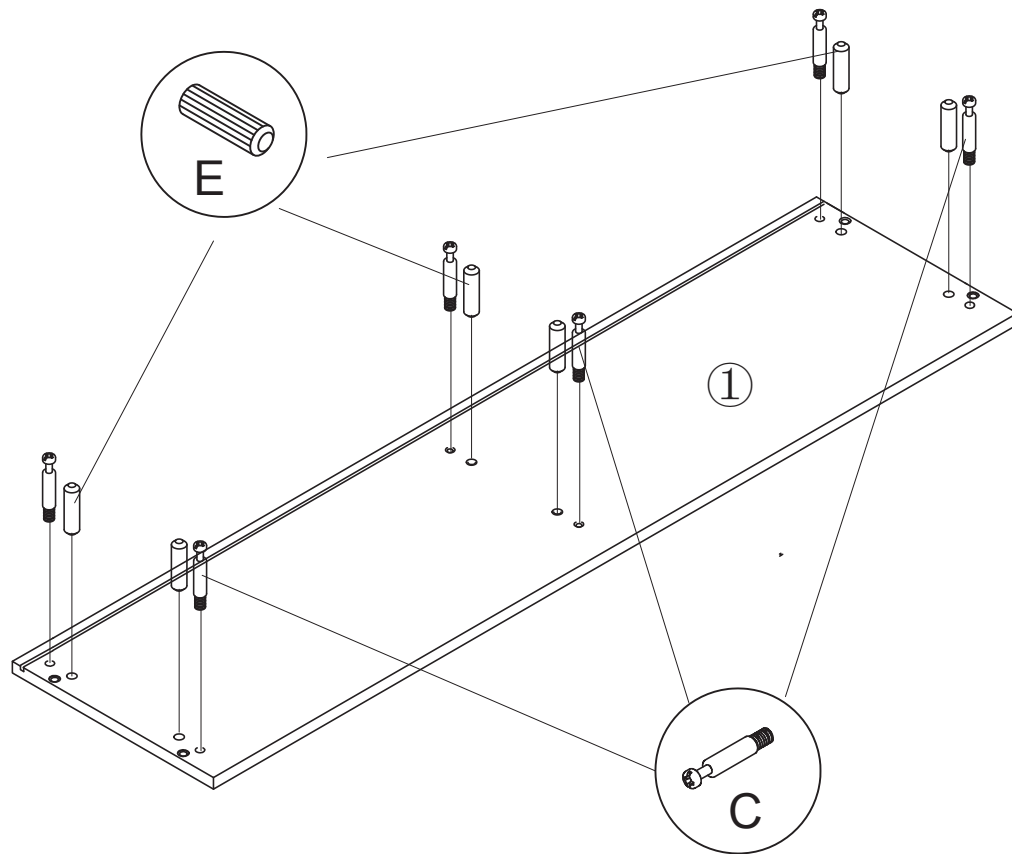
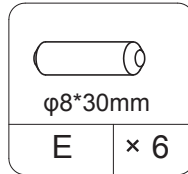
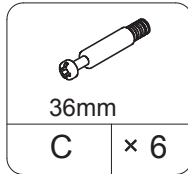
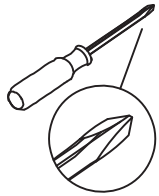

PRODUCT ASSEMBLY

STEP 4

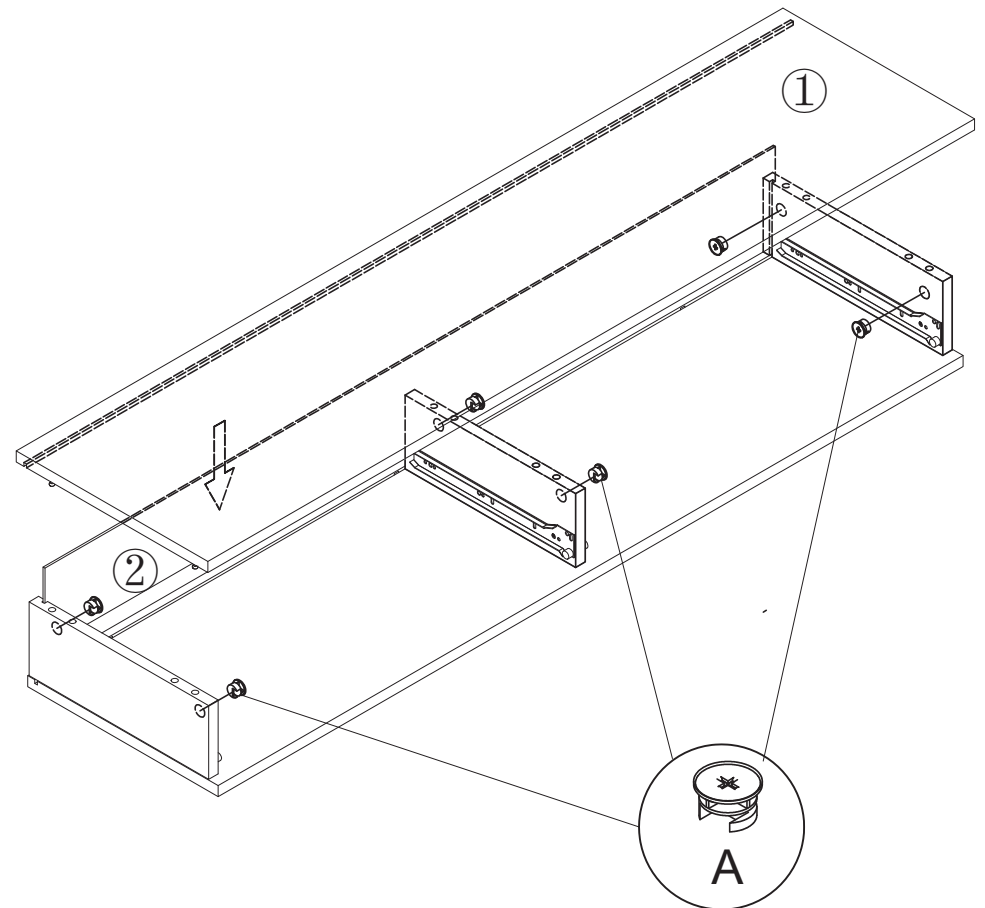
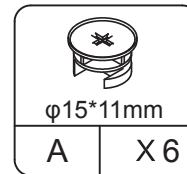
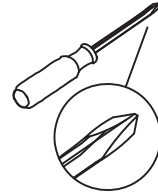

STEP 5

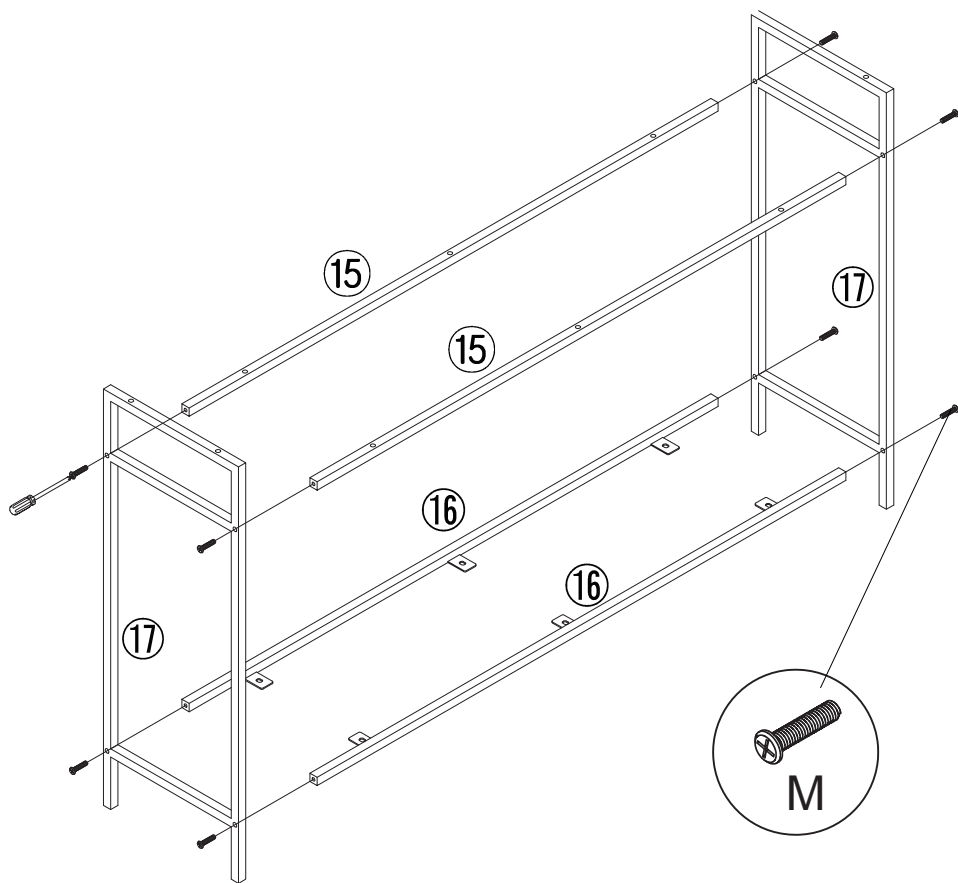
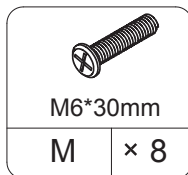
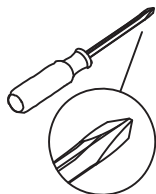

STEP 6

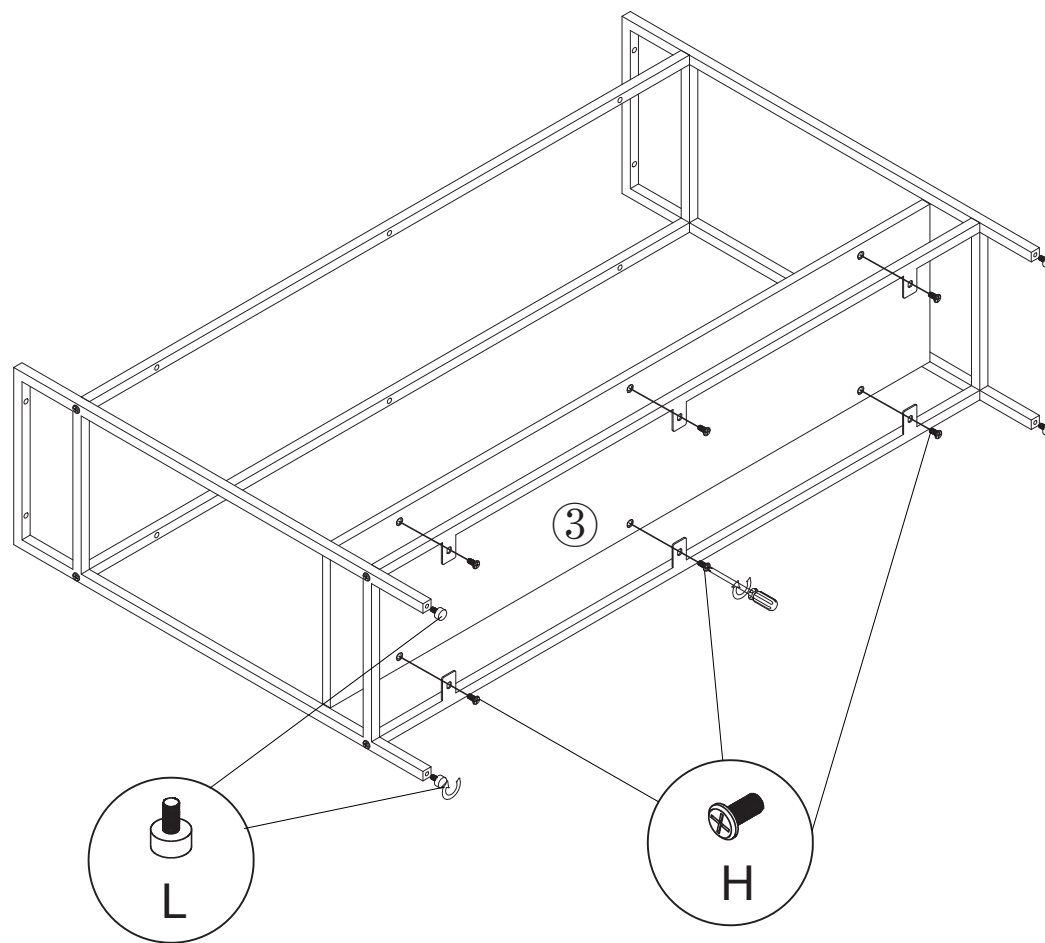
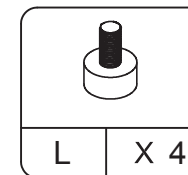
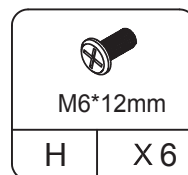

### STEP 7

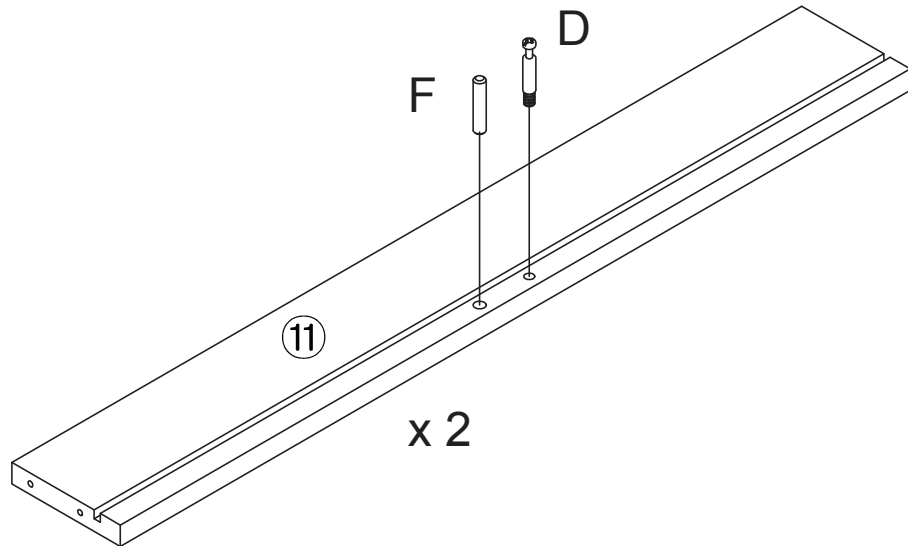
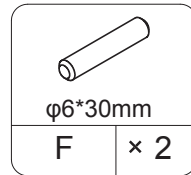
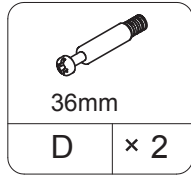
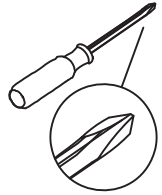

x 2

### STEP 8

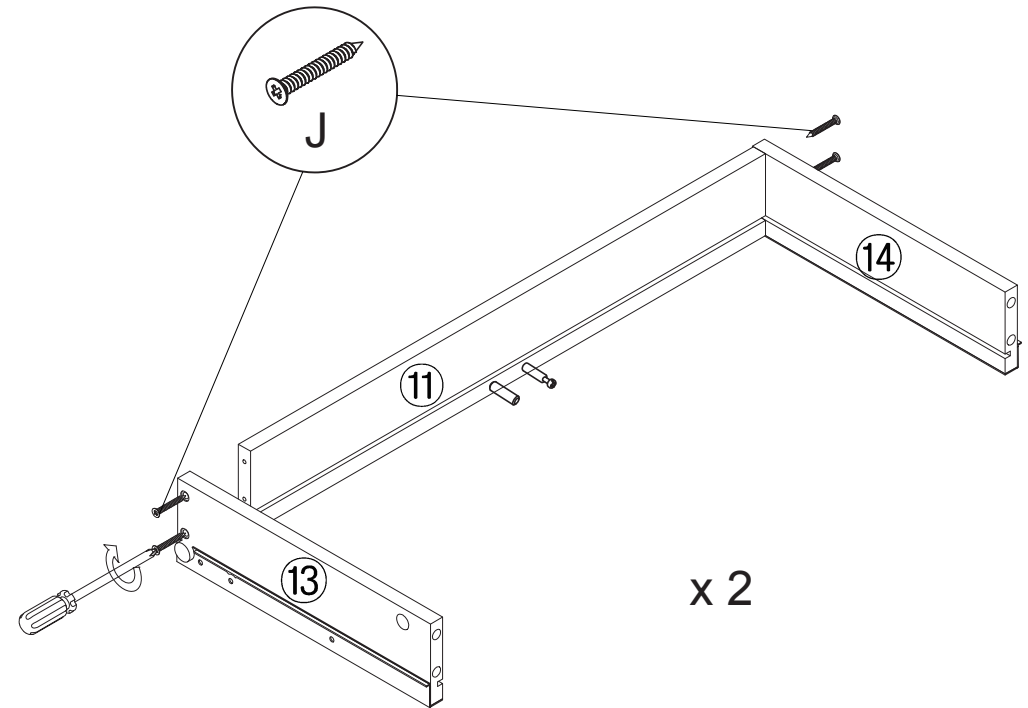
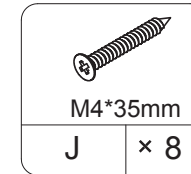

x 2

### STEP 9

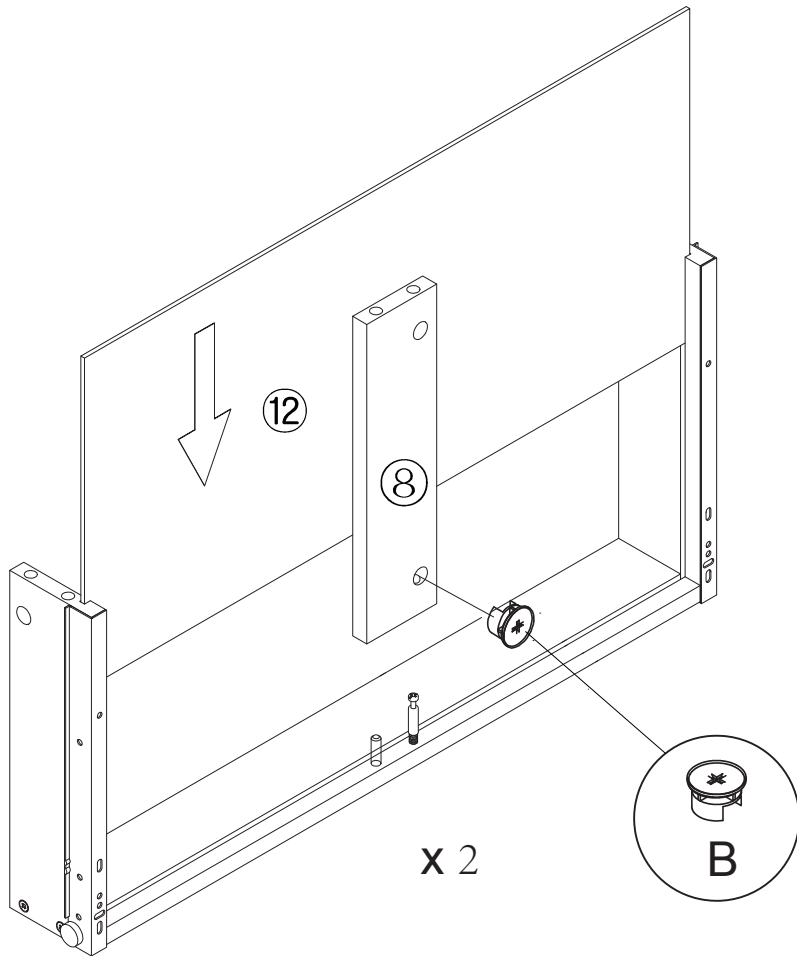
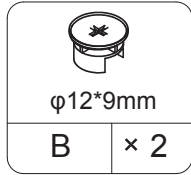
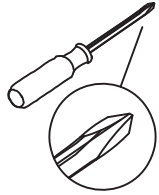

### STEP 10

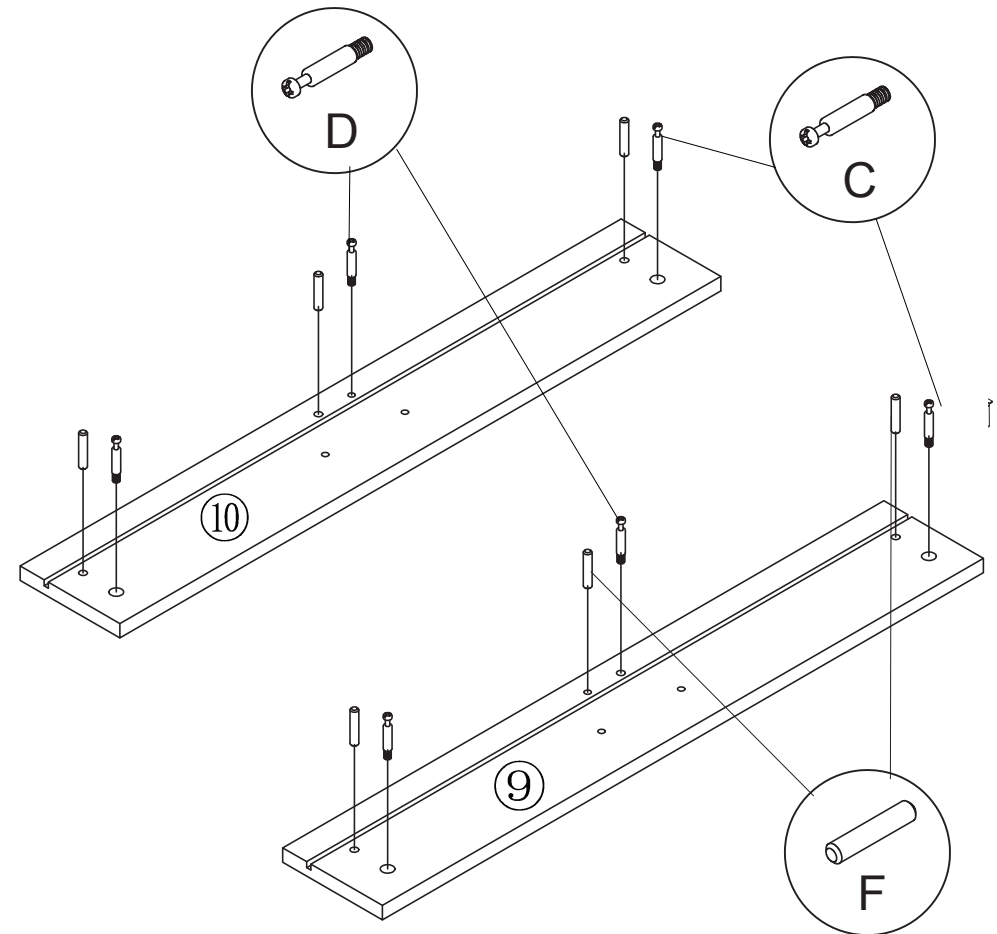
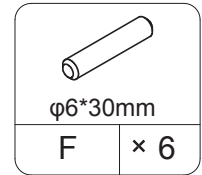
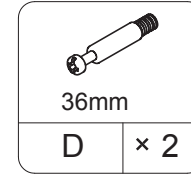
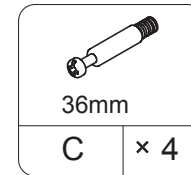
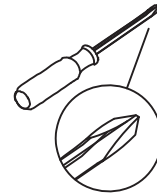

### STEP 11

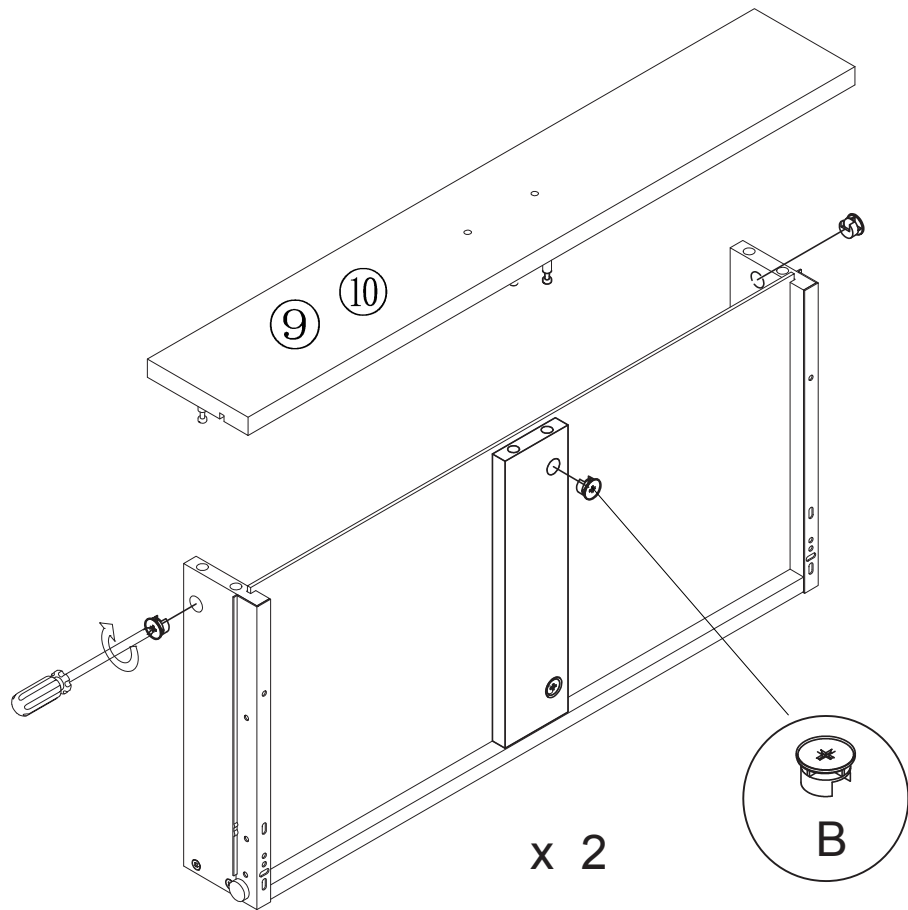
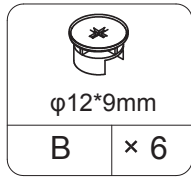
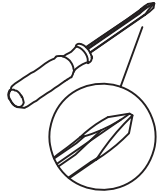

### STEP 12

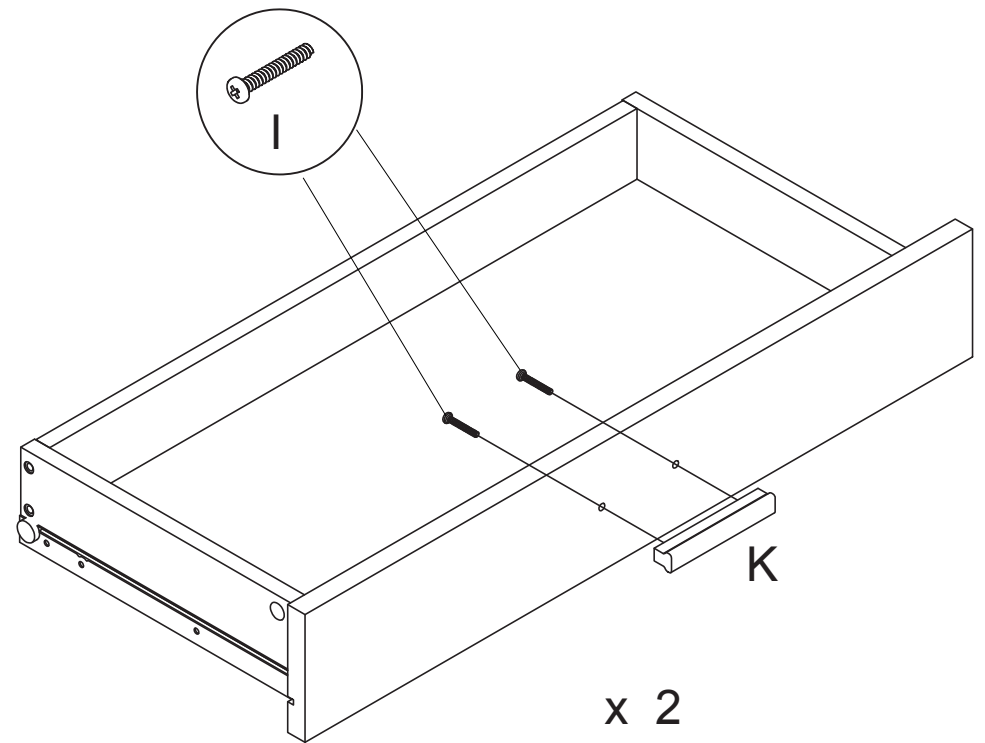
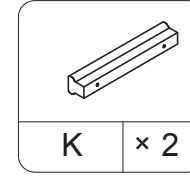
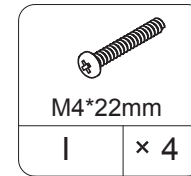
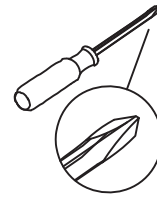

### STEP 13

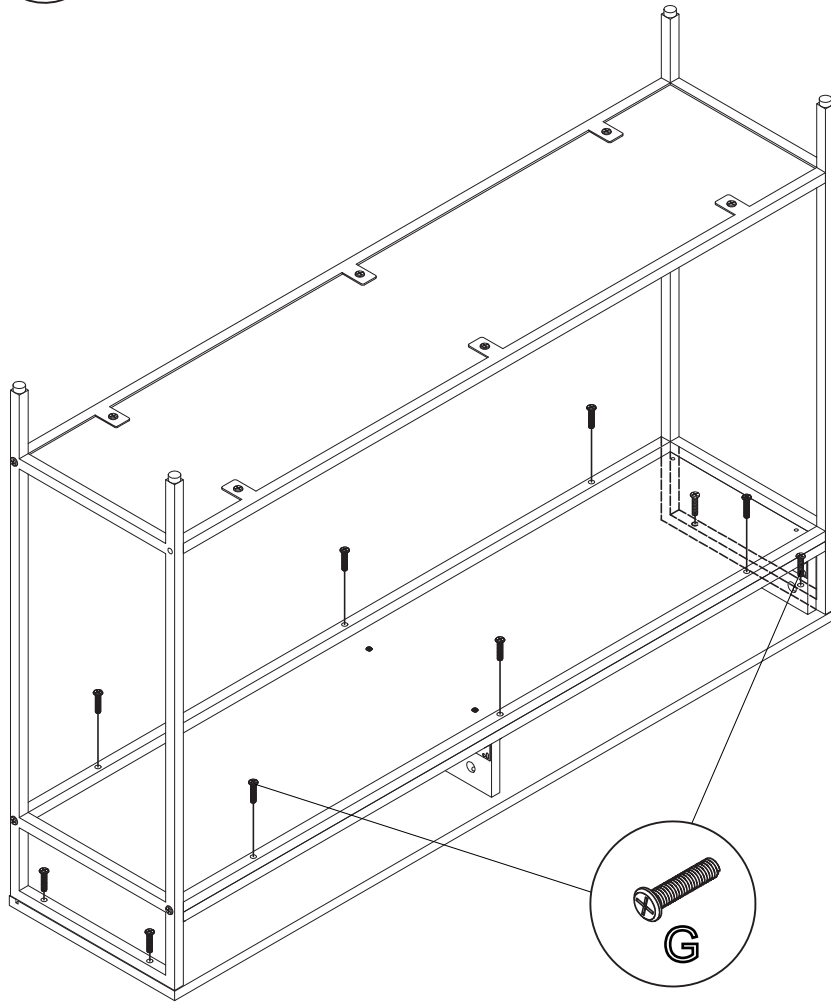
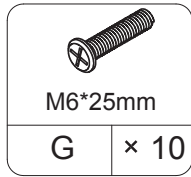
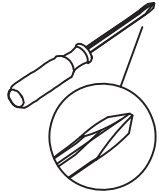

### STEP 14

