

# Assembly Instructions

**Caution : You must read this before you proceed**

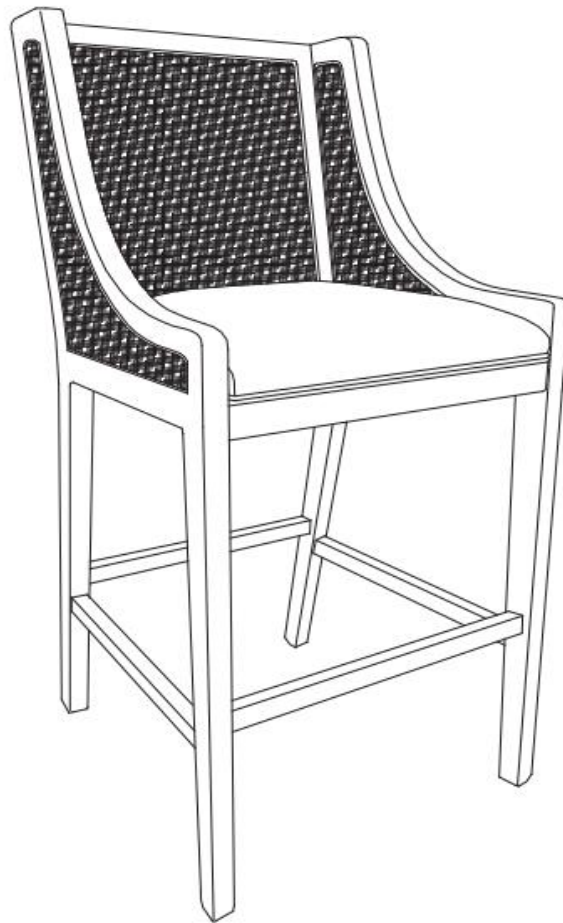



**Please look in the legs for hardware pack.**

## Barstool



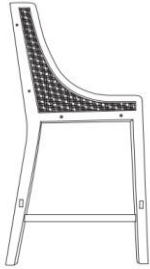

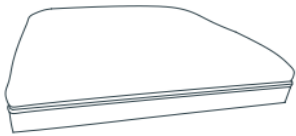



### Parts List

Label	Picture	Description	QTY
A		Left Leg	1

B		Right Leg	1
C		Back	1
D		Seat	1
E		Front Stretcher	1
F		Back Stretcher	1

## Hardware

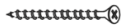
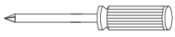
Label	Picture	Description	QTY
①		Bolt (M6*60MM)	5
②		Washer(M6)	5
③		Bolt (M8*50MM)	5
④		Spring Washer	5
⑤		Washer(M8)	5
⑥		Allen Wrench (M6)	1
⑦		Allen Wrench (M8)	1
⑧		Screw (M4x40mm)	5
⑨		Screw driver	1

# Assembly Preparation

Before Beginning Assembly:

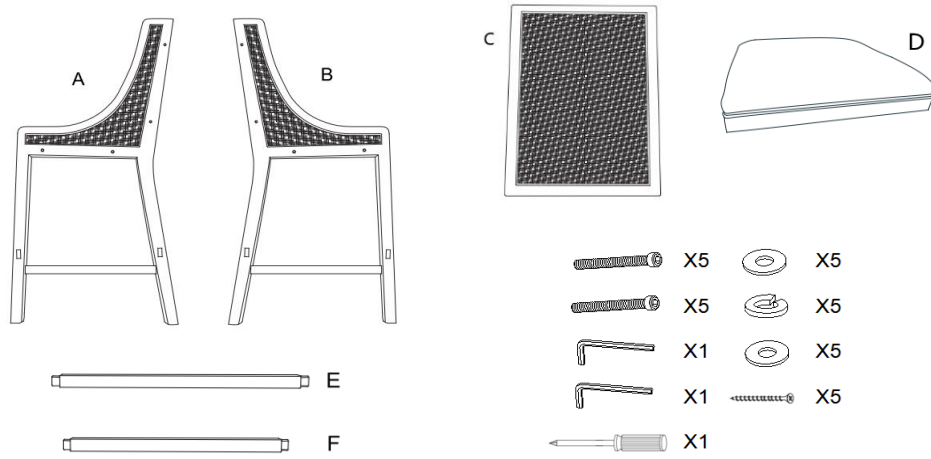

- Read instructions, cover to cover-



- Have 2 adults on hand for assembly-



- Do not assemble on flooring or carpet-



- Assemble on a clean non-marring surface (packing foam)-



- Save all packaging until finished-

# Assembly Steps

## Overview

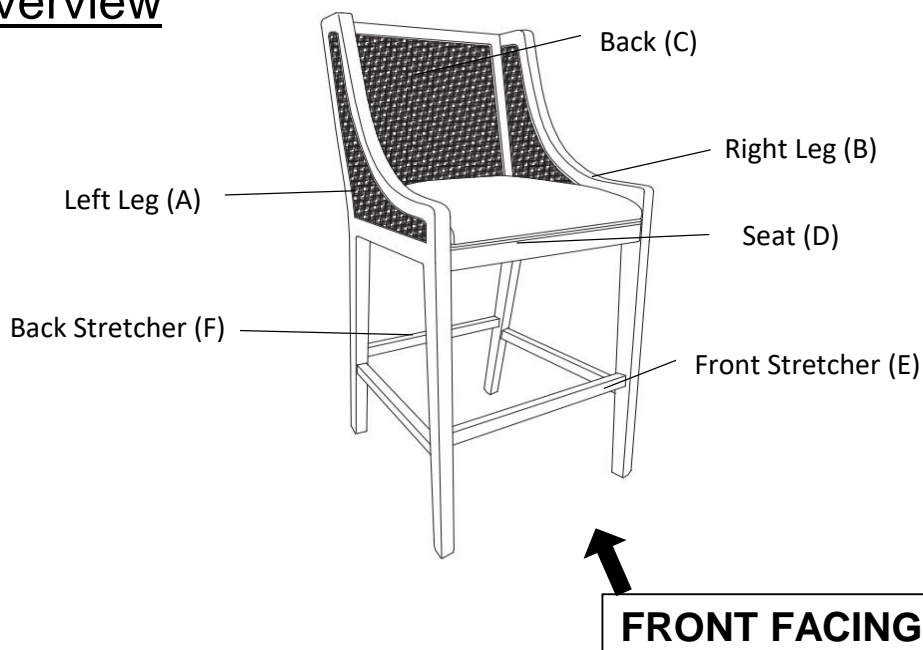

This Barstool has multiple parts and may require up to 30 minutes to assemble. To give you an overview of the Barstool parts, the above picture is to help you put the various parts into perspective. Please read through the instructions below to familiarise yourself with the parts and steps before assembly.

## Step 1

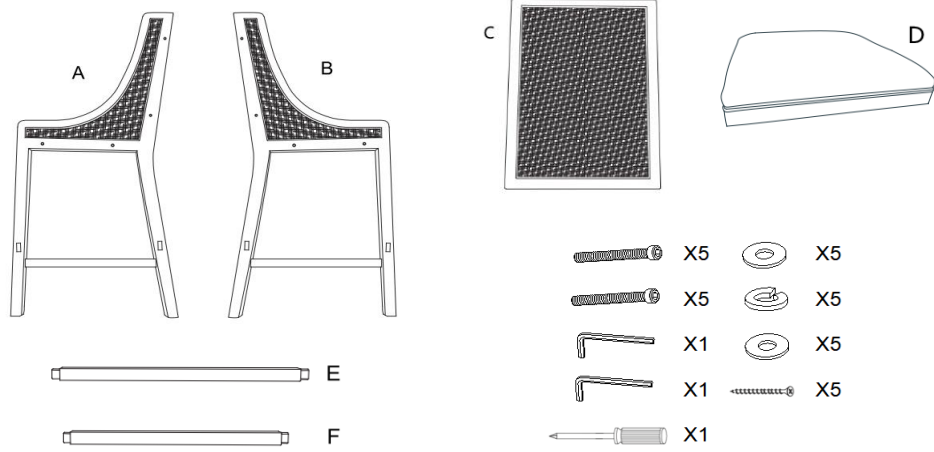

Unpack and place all parts on a clean, non-marring surface.

## Step 2

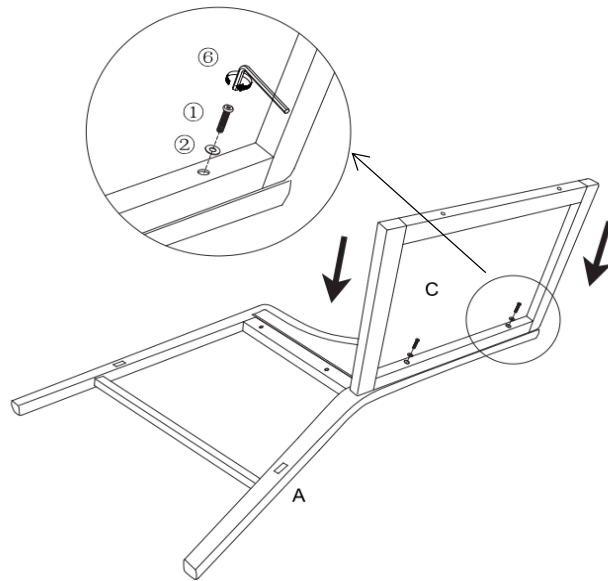

Place the Left Leg(A) on a clean, non-marring surface.

Attach the Back(C) to the mounting positions on the Left Leg(A) using Bolts(①) and Washers(②) with the Allen Wrench(⑥).

**Do not fully tighten Bolts at this time.**

## Step 3

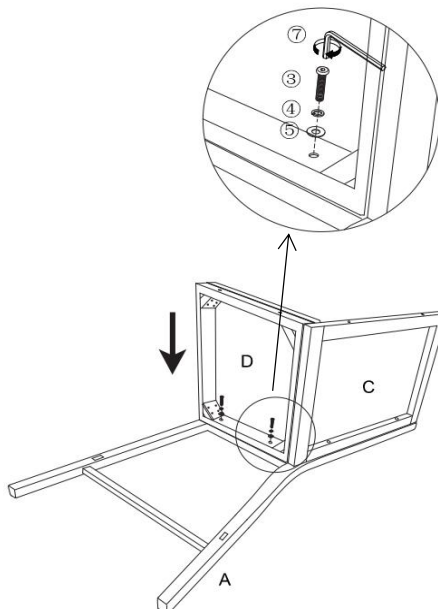

Attach the Seat(D) into the mounting positions of the Left Leg(A) using Bolts(③), Spring Washers(④) and Washers(⑤) with the Allen Wrench(⑦).

**Do not fully tighten Bolts at this time.**

## Step 4

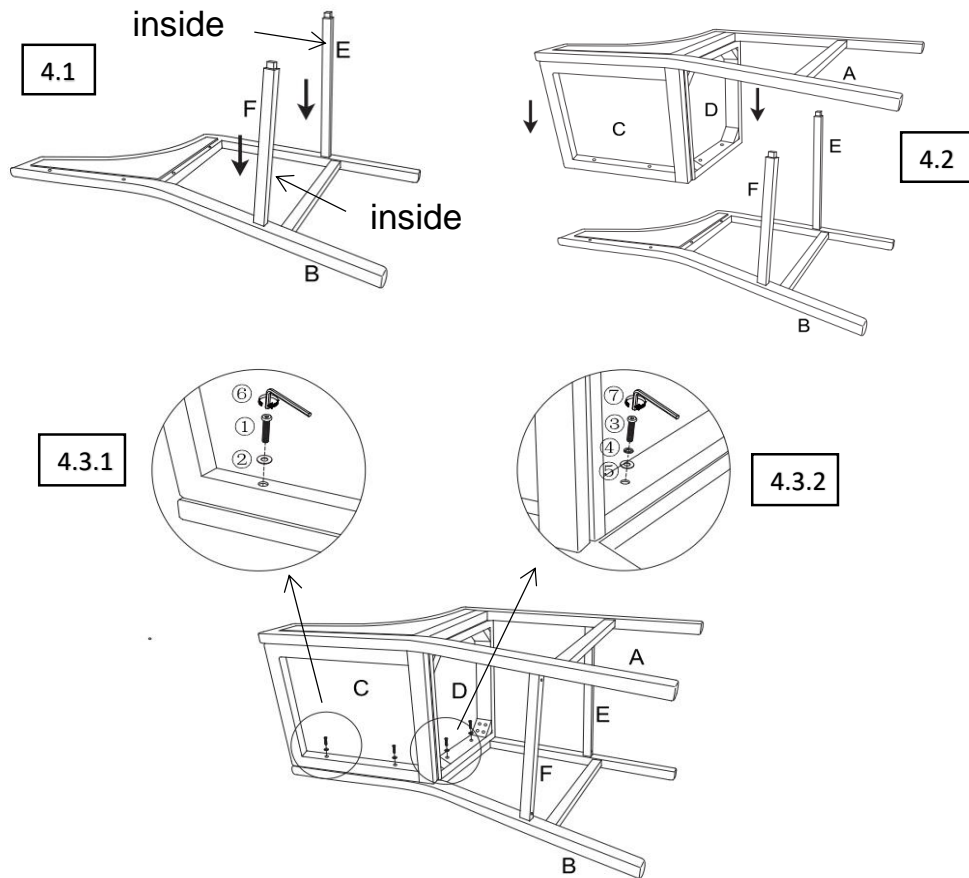

4.1: Attach the Front Stretcher(E) and the Back Stretcher(F) with the inside facing inwards, into the mounting positions on the Right Leg(B) as pictured above.

4.2: Attach the assembled Left Leg(A) & Back(C) & Seat(D) into the mounting positions of the Right Leg(B), Front Stretcher(E) and Back Stretcher(F).

4.3.1: Tighten the Back(C) into the mounting positions of the Right Leg(B) using Bolts(①) and Washers(②) with the Allen Wrench(⑥).

4.3.2: Tighten the Seat(D) into the mounting positions of the Right Leg(B) using Bolts(③), Spring Washers(④) and Washers(⑤) with the Allen Wrench(⑦).

**Do not fully tighten Bolts at this time.**

## Step 5

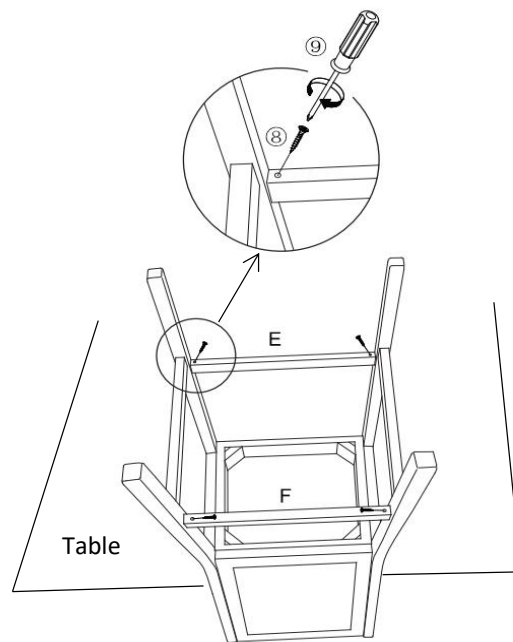

Place the assembled Barstool face down on a clean, non-marring table. Ensure that all the mounting positions on the Stretchers are facing upwards as shown in the picture.

Tight all the Stretchers using Screws(8) with the Screw driver(9).

## Step 6

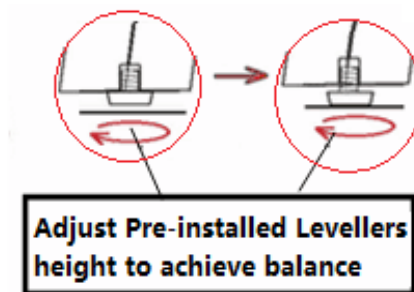
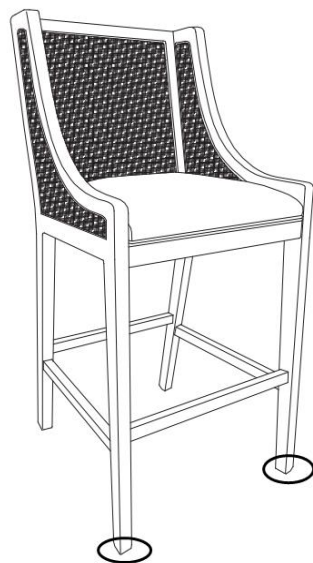

Turn the Barstool right side up.

Check for stability and then tighten all the remaining bolts.

DO NOT fully tighten a bolt in one go and then move on to the next. Rather, in a sequential manner, gradually tighten each bolt until all bolts are evenly secured. This methodology will ensure maximum evenness once all bolts are fully tightened. If the Barstool wobbles adjust the Pre-installed Levellers at the bottom of the Legs until the Barstool is level.

Your Barstool is ready for use.

**This Barstool can only be used on a flat, level surface.**

## Care & Maintenance



- Furniture may scratch floors. We recommend using furniture pads to protect your floors.



- Do not put hot items directly on furniture surface.



- Do not clean furniture with harsh cleansers or polish.



- Do not place furniture under direct sunlight.



- Do not place furniture near heating or cooling vents.



- Do not write on furniture without a padded barrier to protect the surface.



- Do not place furniture outside . For indoor use only.



- Not for commercial use. For residential use only.



- Stains may be removed with mild soap solution and damp cloth.



- Children should not climb or jump on the furniture.



- Dust and pick-up spills using a clean, non-colored, lint-free cloth.