

## Resin Garden Shed

OWNER'S MANUAL  
Instructions for Assembly

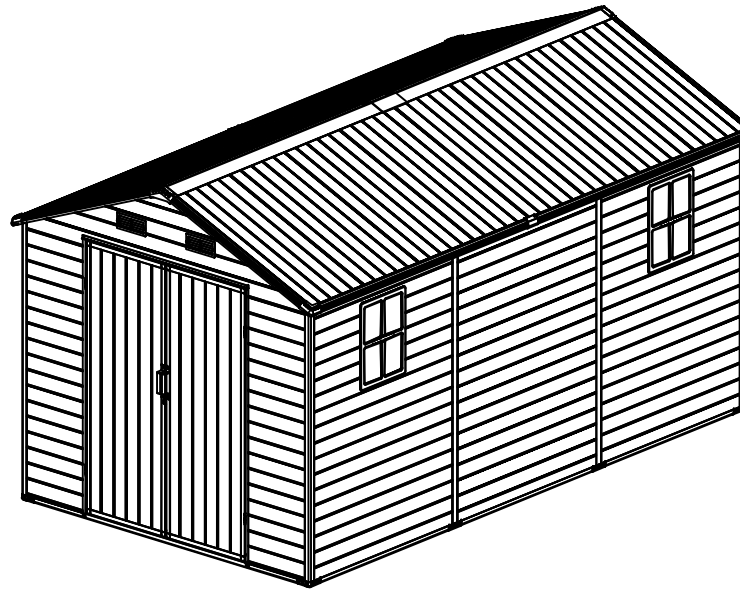

---

## SLD-AM148

Requires three people and take 6-8 hours for installation.  
Quick & Easy assembly. Ridge Reinforced Walls.

If you have any advice or problem, please contact us :  
[wxservice@5xfuture.com](mailto:wxservice@5xfuture.com)

## BEFORE YOU START

---

### Owner's Manual

Prior to installation, it is important that you contact your local government authority to determine if building approval is required. Study and understand this owner's manual. Important information and helpful tips will make your construction easier and more enjoyable.

### Assembly instructions

Instructions are supplied in this manual and contain all appropriate information for your building model. Review all instructions before you begin. During assembly, follow the step sequence carefully for correct results. Please be aware: this unit takes two people about one full day to complete.

### Parts

Check to be sure that you have all the necessary parts for the building.

Separate contents of the carton by the part number while reviewing parts list.

Familiarize yourself with the hardware and fasteners for easier use during construction. These are packaged within the carton. Note that extra fasteners have been supplied for your convenience.

## TOOLS MAY REQUIRED

---

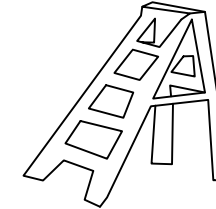
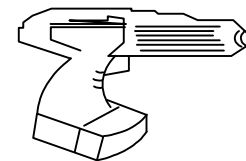
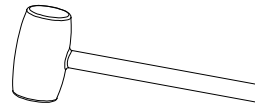
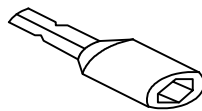
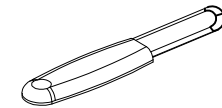
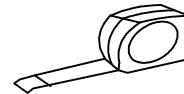
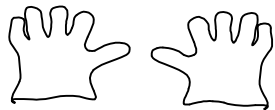

Use heavy duty gloves when handling steel sheets and flashing

---

## PLAN AHEAD

---

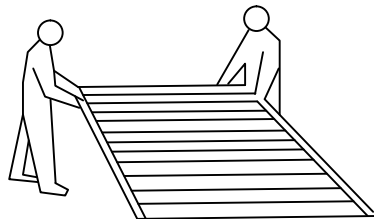

### Watch the weather:

Please be sure the day you select for installation is dry and calm.

**DO NOT** attempt to assemble your shed in windy weather

because of risk of damage to panels, or personal injury. Be careful of wet or muddy ground.

### Teamwork:

Whenever possible, two or more people should work together to assemble the building. One person can position parts or panels

# PLAN AHEAD

---

## Site Selection

Avoid overhanging trees as much as possible as leaves will make regular cleaning necessary and broken branches are a potential hazard.

Small trees, bushes or fences nearby can be helpful, acting as a wind break.

If a concrete pad is made, it is important that this slopes towards the edges to prevent water ingress.

Time must be allowed for any concrete or cement to dry before building the shed on top.

## Site Preparation

The site must be prepared so that the base of the shed is level all round and checking with a spirit level is required.

The base can be constructed by treated timber or concrete, in order to stop the moisture getting into the shed. The shed is not designed to be built onto lawn directly. Also the ground will get muddy during rainy days.

Bases can also be constructed from bricks, blocks, or mounted on a concrete pad.

The bricks or blocks should be cemented onto firm and level concrete footings and the greenhouse frame drilled and screwed to the base.

---

## IMPORTANT NOTES:

---

Find someone to help you: it is much easier with someone to hold parts, pass tools ect. Also some steps require two people to lift structures together. This is not very heavy work so would suit most able-bodied people.











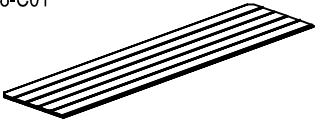



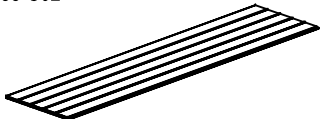



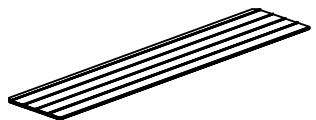

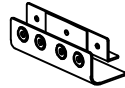

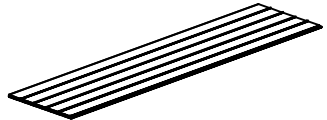

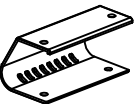

Allow plenty of time: rushing often causes errors and the re-doing of incorrect assemblies. If you have never built a shed before, it can take most of a day to carefully complete the construction.

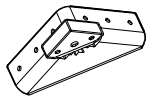

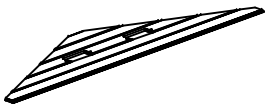

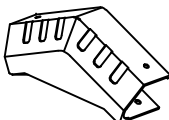

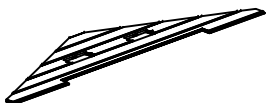
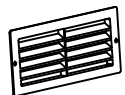
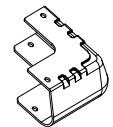

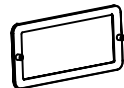
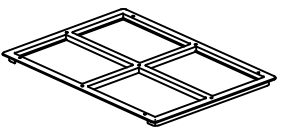

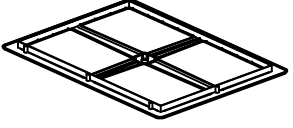



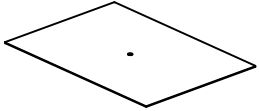



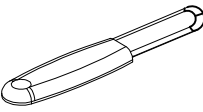







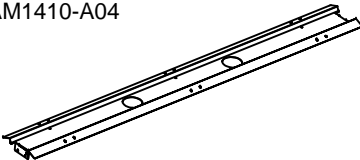

Have the right tools to hand.

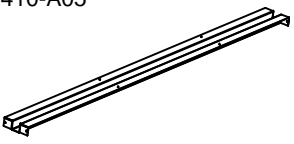
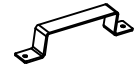

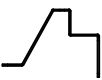
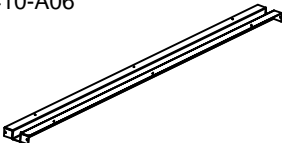



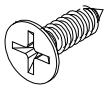
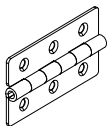
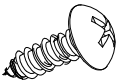
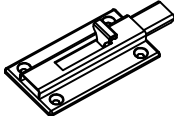

Safety clothing as recommended in the 'Tools' section.

Ideally lay out the parts and check that all are present before commencing construction. Lay on cloths or plastic sheets if there is any risk of scratching the parts.

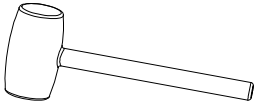
Tighten all nuts carefully, being sure not to miss any. Check the frame is square and using a spirit level to check that it is upright.

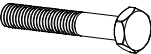
AM88-C01 	x 1	AM1410-C11 	x 16	AM148-C02 	x 2	AM88-C24 	x 1
AM88-C02 	x 6	AM1410-C12 	x 2	AM88-C18 	x 4	AM88-C25 	x 8
AM148-C01 	x 1	AM1410-C13 	x 2	AM148-C03 	x 4	A64-C30 	x 4
AM88-C04 	x 2	AM88-C12 	x 3	AM88-C20 	x 4	A812-C26 	x 2
AM88-C05 	x 2	AM88-C13 	x 1	AM148-C04 	x 4	F35-C27 	x 4
AM88-C06 	x 6	AM88-C14 	x 1	AM88-C22 	x 14	A64-C29 	x 2
AM88-C07 	x 2	AM88-C15 	x 1	GF 	x 4	F35-C30 	x 4
AM1410-C10 	x 4	AM88-C16 	x 16	AM88-C23 	x 4	F35-C31 	x 2

F35-C32		x 2	AM88-A06		x 2	AM88-A12		x 1	AM88-A19		x 1
F35-C33		x 2	AM88-A07		x 4	AM88-A13		x 2	AM88-A20		x 1
F35-C34		x 1	AM88-A08		x 2	AM88-A14		x 4	AM88-A21		x 4
AM88-A01		x 1	AM1410-A03		x 2	AM88-A15		x 8	AM88-A22		x 4
AM88-A02		x 1	AM1410-A04		x 1	AM88-A16		x 4	AM1410-A11		x 6
AM88-A03		x 1	AM1410-A05		x 4	AM88-A17		x 2	AM88-A24		x 2
AM88-A04		x 1	AM1410-A06		x 2	C35-A12		x 2	AM88-A25		x 4
AM88-A05		x 1	AM88-A10		x 4	AM88-A18		x 2			

E01		x 34	A64-A15 	x 4				
E02		x 668	G6 	x 2				
E03		x 32	D03 	x 1				
E04		x 8						
E08		x 28						
E09		x 28						
E12		x 28						
E13		x 20						

# Pre-installed Exploded View

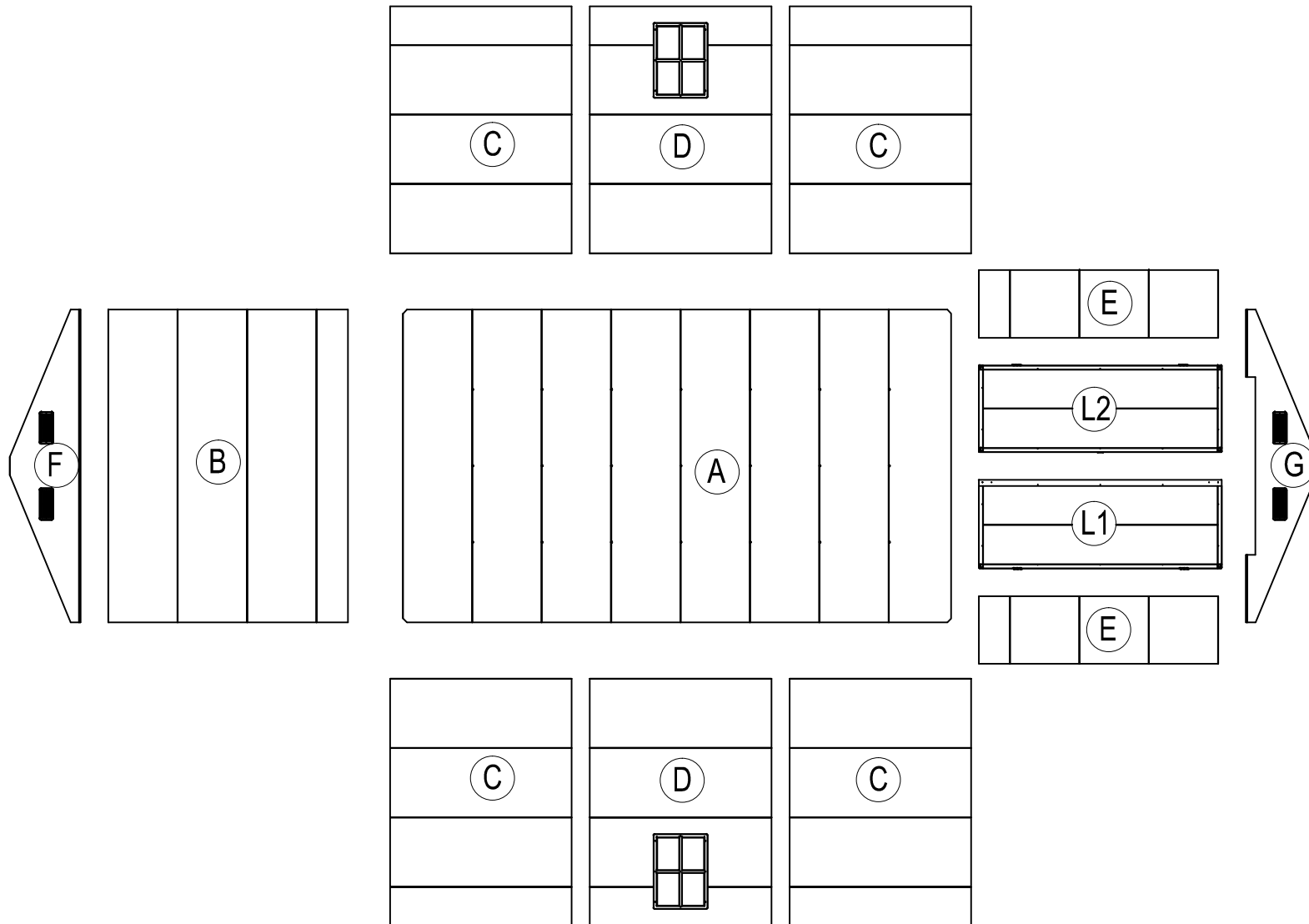

# Pre-installed Exploded View

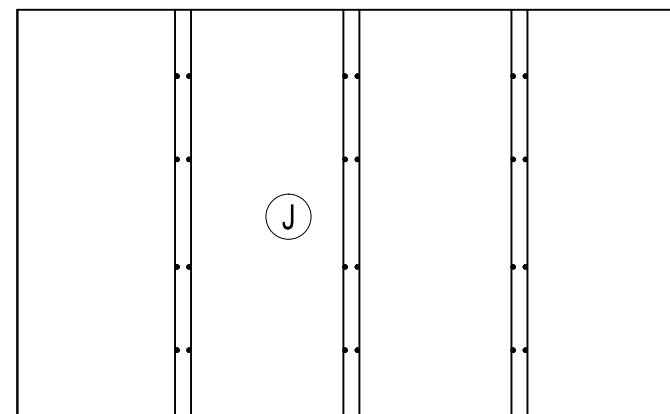
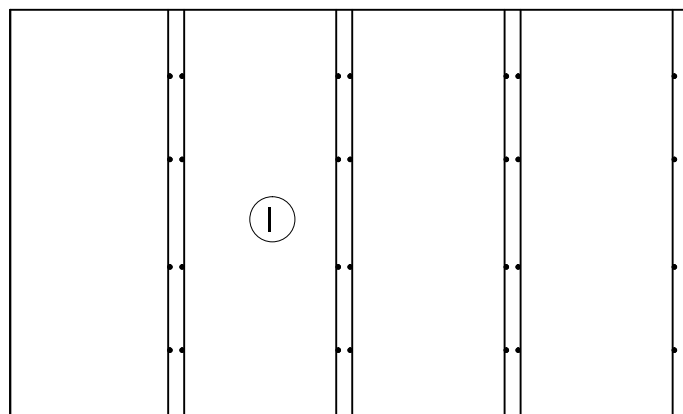

# Pre-installed Exploded View

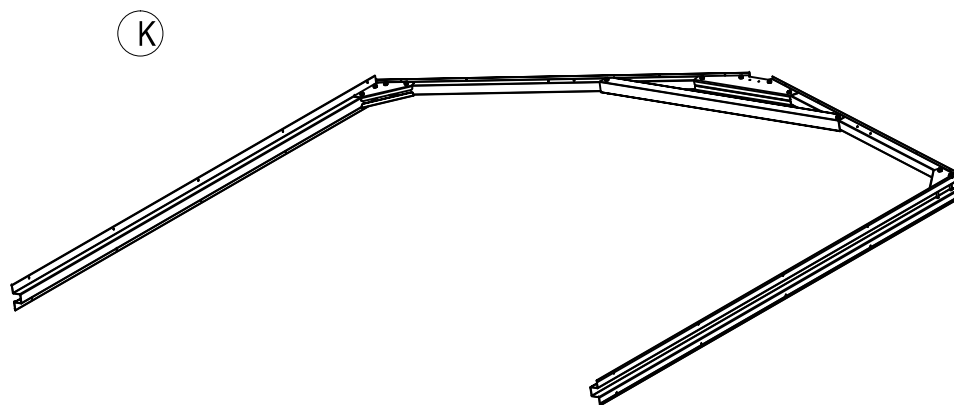

AM88-C01x 1

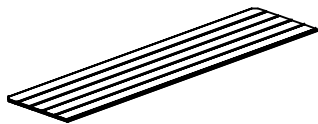

AM88-C02x 6

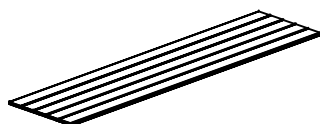

AM148-C01 x 1

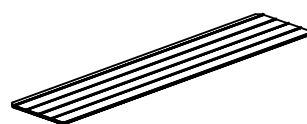

E02 x 21



## Basement Pre-assembly

# A

All panels have a rough side and a smooth side. When installing, make sure that the smooth side is toward the inside of the storage shed.

There are card slots on all panels. Align the panel and push it directly with force when installing panels; if it can't be pushed, you can stand the panel up and use the sliding type installation.

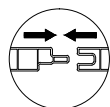

Place the panel smooth side up, knock the panel tightly by using hammer to make sure the panel is tightly fitted. This will prevent leaks, and then secure it with screws.

It is recommended to have three people install this at the same time, this will help with a better installation.

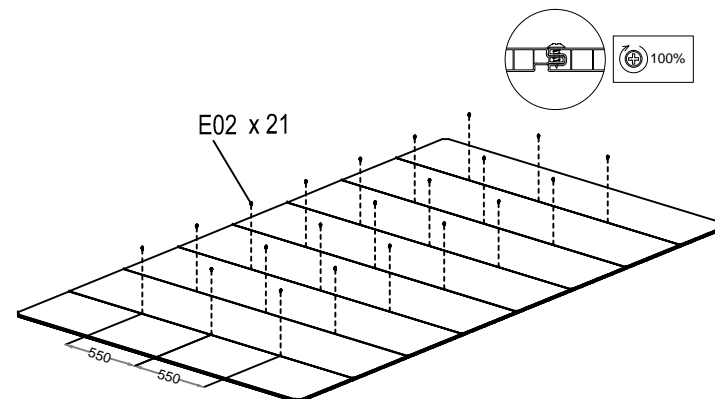
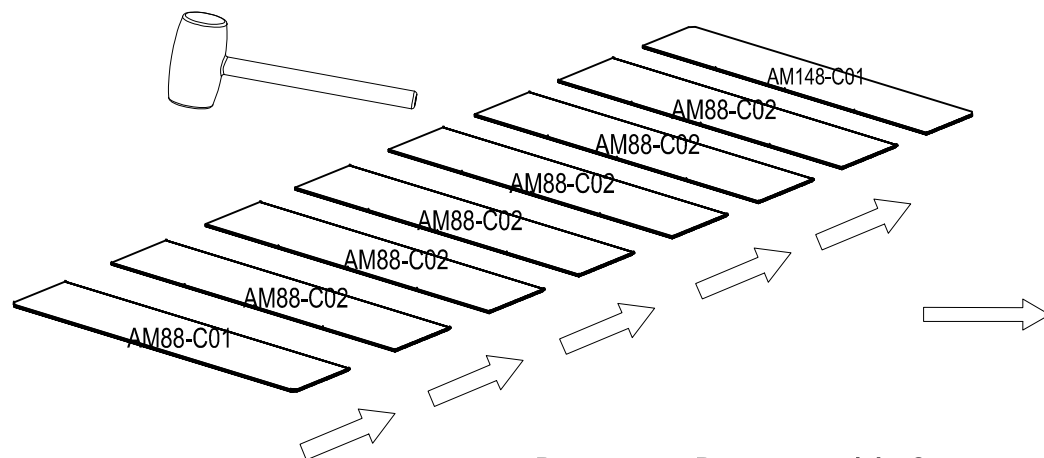

### Basement Pre-assembly Step

1. Assemble the eight panels together.
2. Use a rubber hammer or other means to make each face or edge of the assembled panel level and leave no gaps.
3. Fix the connection part of the panel tightly with screws.

AM88-C12 x 3



AM88-C13 x 1



E02 x 9



## Back wall Pre-assembly

### B

### Back wall Pre-assembly Step

1. Assemble the four panels together.
2. Use a rubber hammer or other means to make each face or edge of the assembled panel level and leave no gaps.
3. Fix the connection part of the panel tightly with screws.

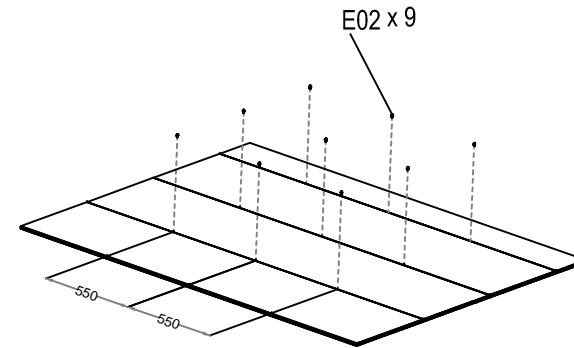
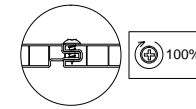
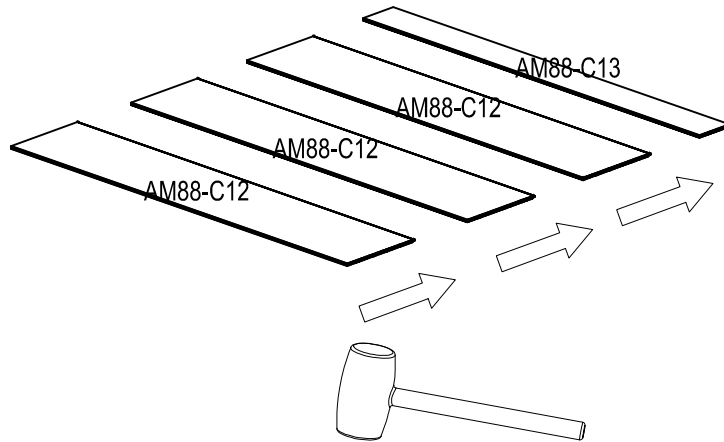
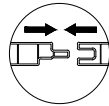

AM1410-C10 x 4



AM1410-C11 x 12



E02 x 24



## Side wall Pre-assembly

# C

x4

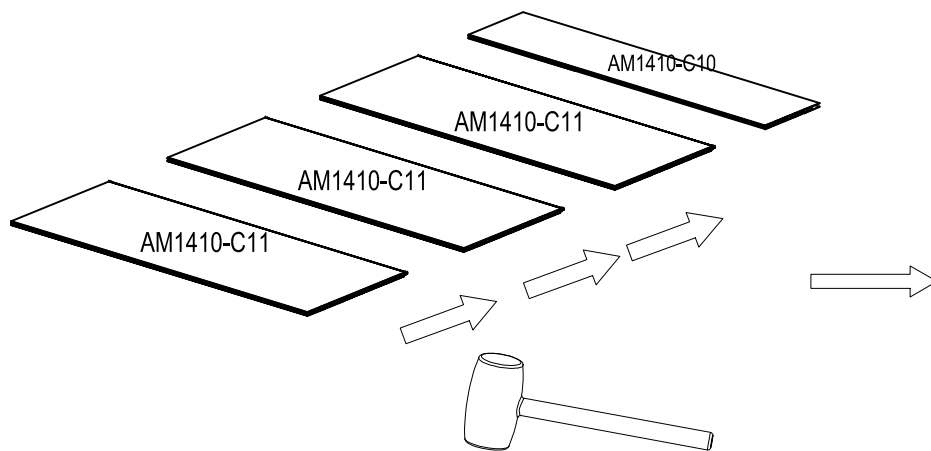
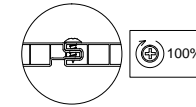
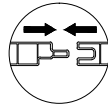

### Side wall Pre-assembly Step

1. Assemble the four panels together.
2. Use a rubber hammer or other means to make each face or edge of the assembled panel level and leave no gaps.
3. Fix the connection part of the panel tightly with screws.
4. Repeat four times.

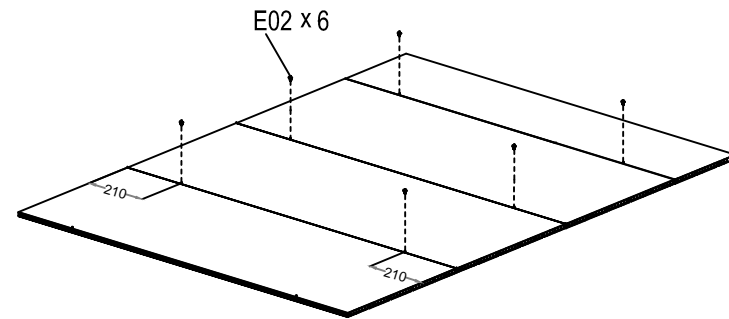

AM1410-C11 x 4

AM1410-C12 x 2

AM1410-C13 x 2

F35-C32 x 2

F35-C31 x 2

F35-C33 x 2

E02 x 15

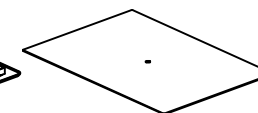
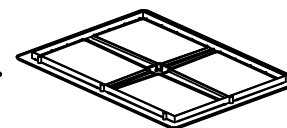
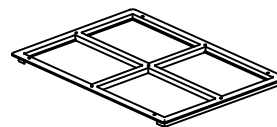
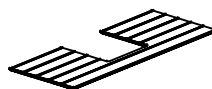

## Side wall Pre-assembly

### D

x2

I

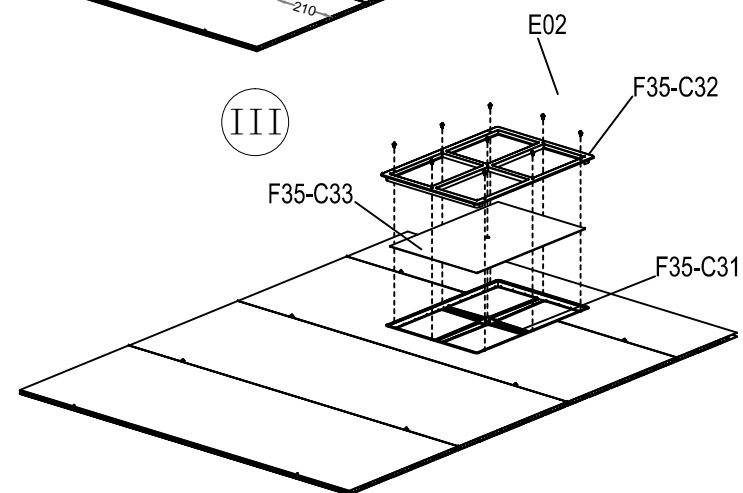
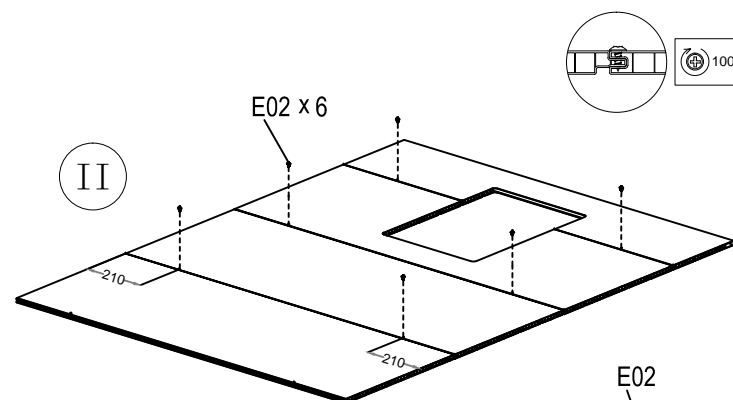
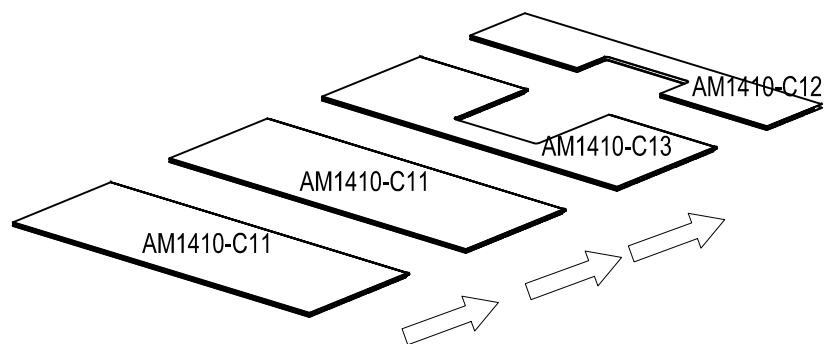
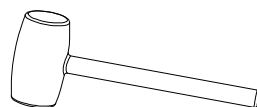
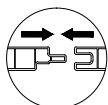

### Side wall Pre-assembly Step

1. Assemble the four panels together.
2. Use a rubber hammer or other means to make each face or edge of the assembled panel level and leave no gaps.
3. Fix the connection part of the panel tightly with screws.
4. Install windows and tighten screws.
5. Repeat twice.

AM88-C06 x 6



AM88-C07 x 2



E02 x 12



## Front wall Pre-assembly

E

x2

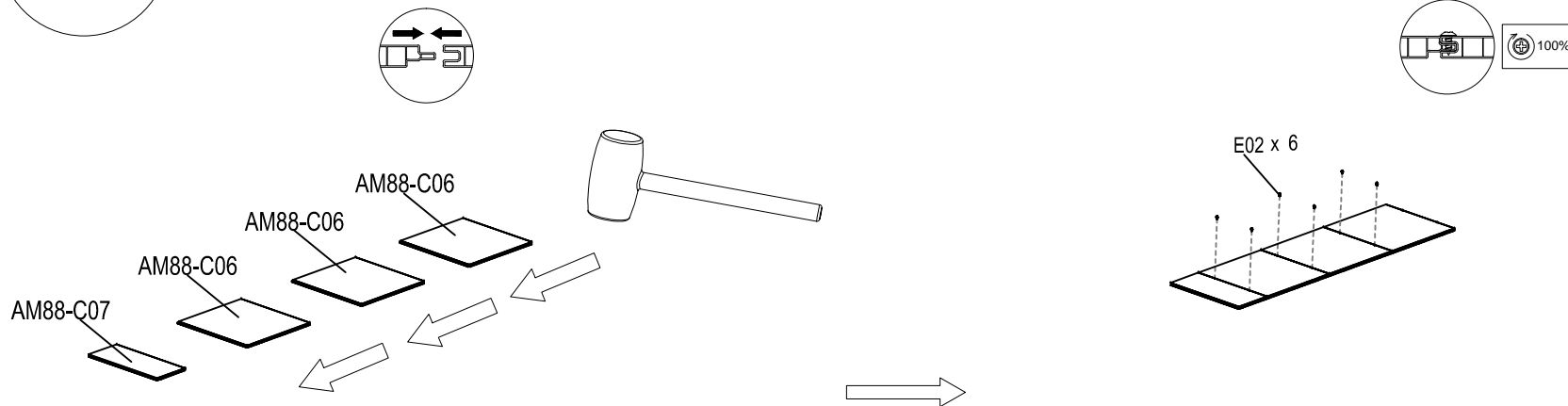

### Front wall Pre-assembly Step

1. Assemble the four panels together.
2. Use a rubber hammer or other means to make each face or edge of the assembled panel level and leave no gaps.
3. Fix the connection part of the panel tightly with screws.
4. Repeat two times.

GF x 2

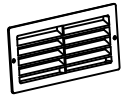

AM88-C23 x 2

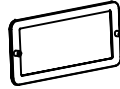

AM88-C14 x 1



E02 x 4



## Triangle board Pre-assembly

# F

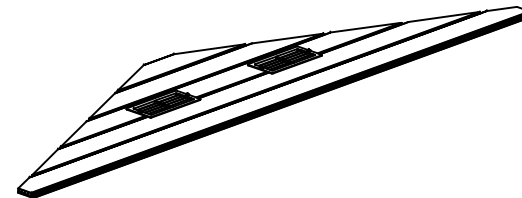
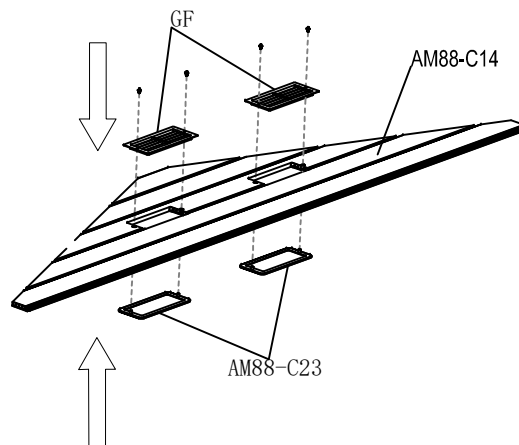

### Triangle board Pre-assembly Step

1. Assemble the components of the triangle board together.
2. Fix with screws.
3. Repeat twice.

GF x 2

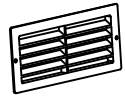

AM88-C23 x 2

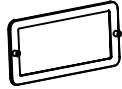

AM88-C15 x 1



E02 x 4



## Triangle board Pre-assembly

# G

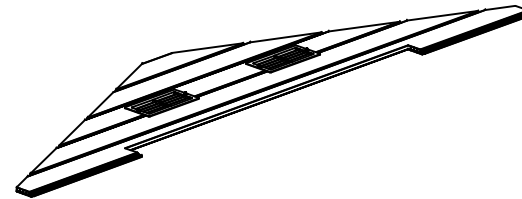
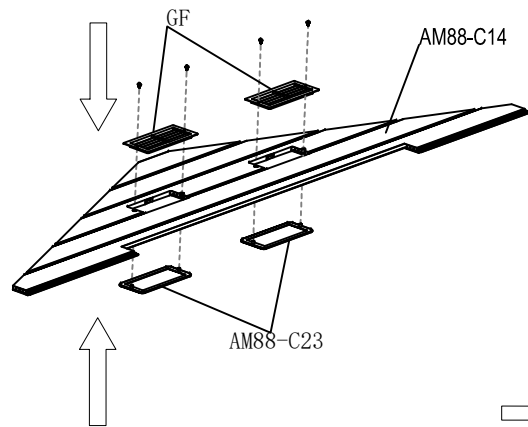

AM88-C04 x 1

AM88-C05 x 1

AM88-A21 x 2

AM88-A18 x 1

AM88-A19 x 1

AM88-C25 x 4

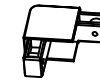

## Door Pre-assembly

### L1

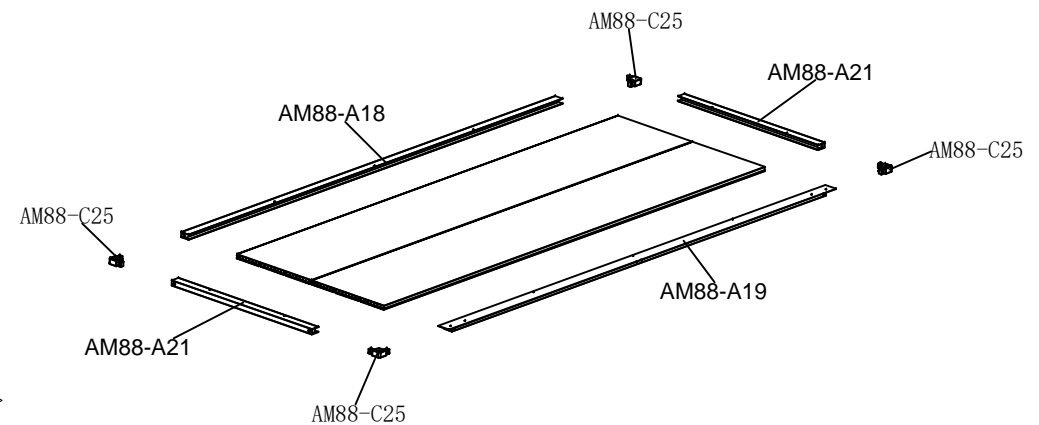
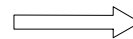
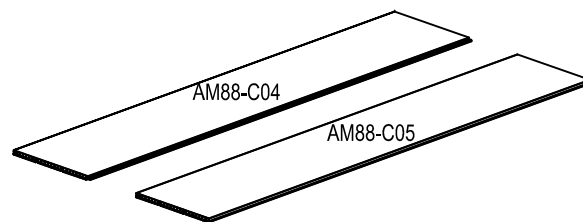

#### Door Pre-assembly Step :

1. Assemble the two panels together.
2. Use a rubber hammer or other means to make each face or edge of the assembled panel level and leave no gaps.
3. Take out the corresponding door frame components.
4. As shown in the figure, clip the upper, lower, left, and right door frames around the panel.
5. Measure the diagonal of the door frame to ensure that the distance between the two diagonals is consistent.

A64-A15 x 2

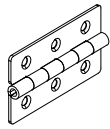

AM88-A17 x 1

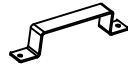

C35-A12 x 1



G6 x 2

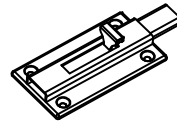

E12 x 6

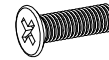

E02 x 16

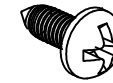

E01 x 12

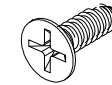

## Door Pre-assembly

### L1

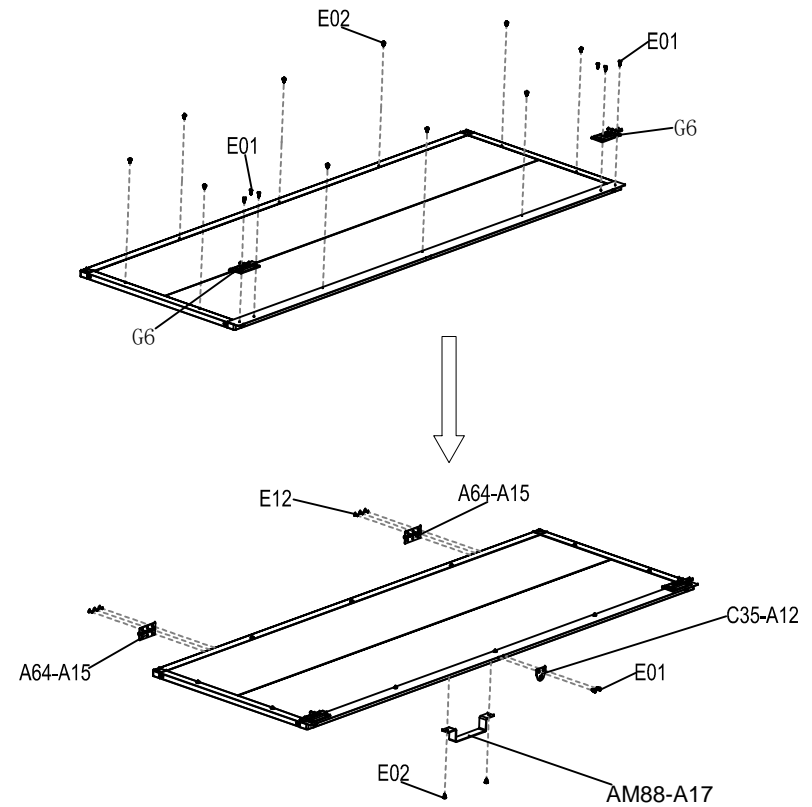
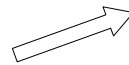
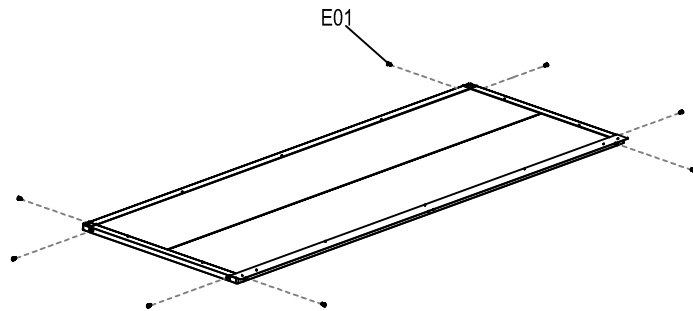

#### Door Pre-assembly Step :

1. Fix the four corner protectors with screws.
2. Fix along the pre drilled hole of the door frame with screws.
3. Install door locks, hinges, and handles.

AM88-C04 x 1

AM88-C05 x 1

AM88-A21 x 2

AM88-A18 x 1

AM88-A20 x 1

AM88-C25 x 4

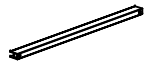

## Door Pre-assembly

### L2

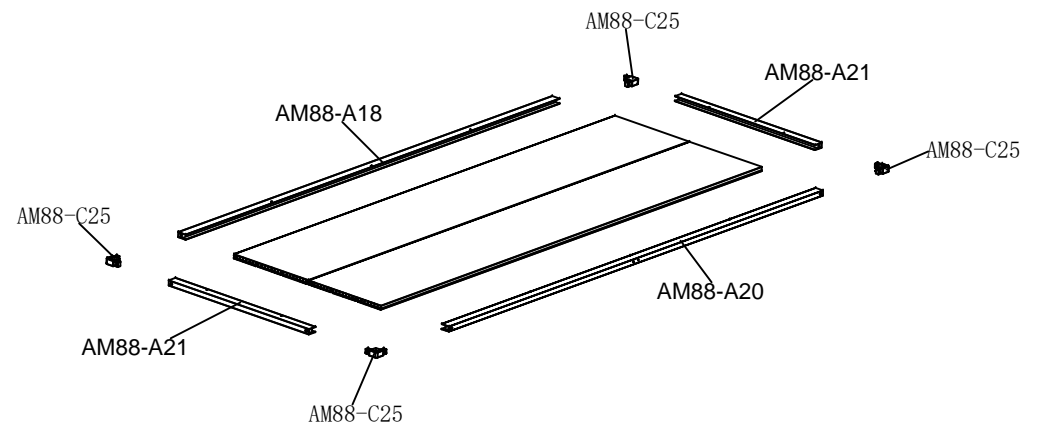
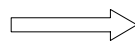
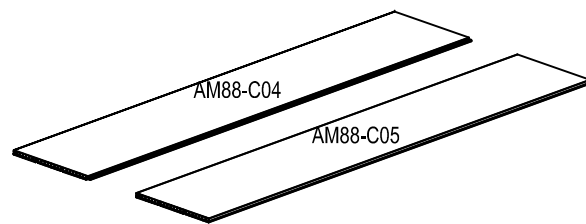

Door Pre-assembly Step :  
Refer to the previous installation steps.

A64-A15 x 2

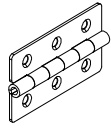

AM88-A17 x 1

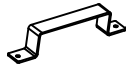

C35-A12 x 1



E12 x 6

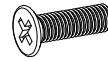

E02 x 10

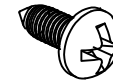

E01 x 10

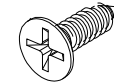

## Door Pre-assembly L2

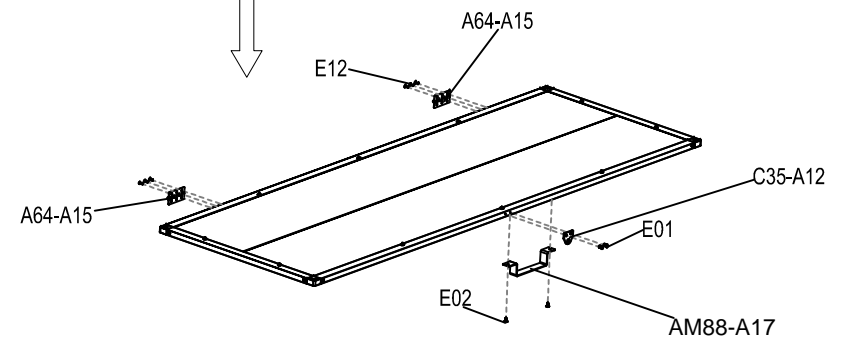
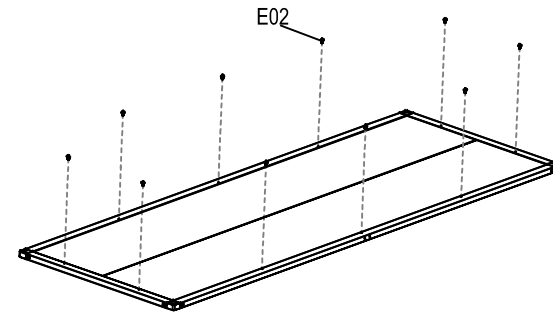
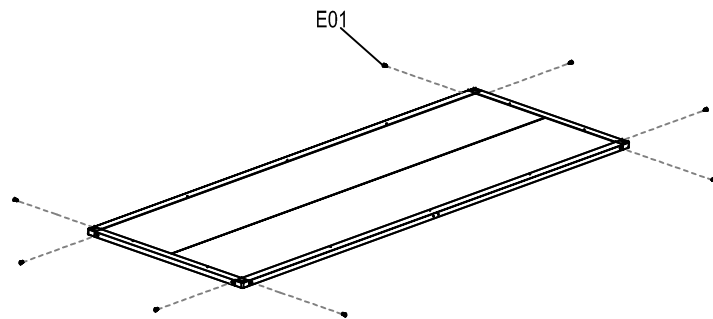

AM88-C16 x 8



AM88-C22 x 8



E02 x 56

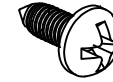

## Roof Pre-assembly

I  
x2

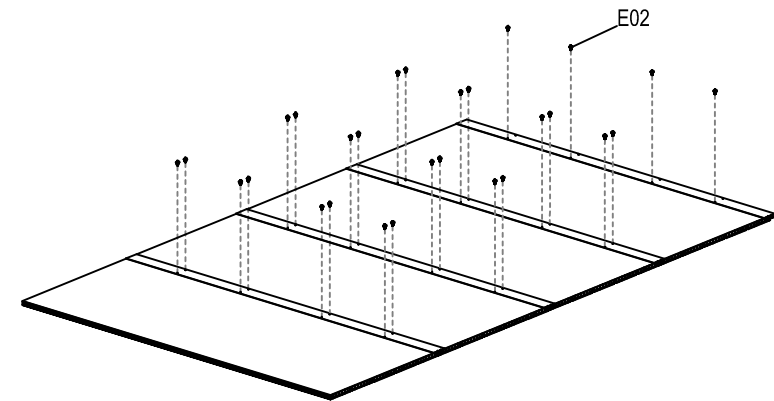
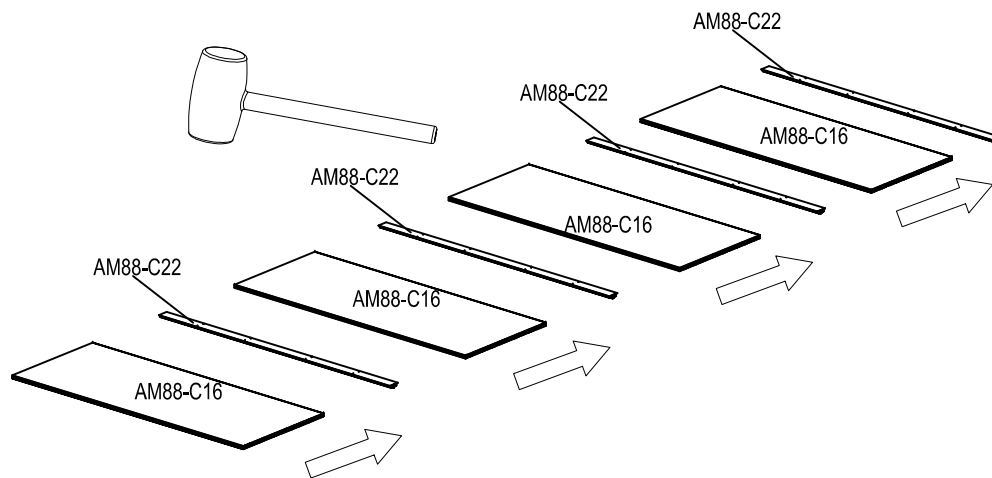

### Roof Pre-assembly Step

1. Connect the four panels together through the grooves on both sides of AM88-C22.  
(As shown in the figure, there are a total of 4 “ AM88-C22 ” )
2. Use a rubber hammer or other means to make each face or edge of the assembled panel level and leave no gaps.
3. Use screws to fix the panel tightly.
4. Repeat twice.

AM88-C16 x 8



AM88-C22 x 6



E02 x 48

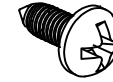

## Roof Pre-assembly

J  
x2

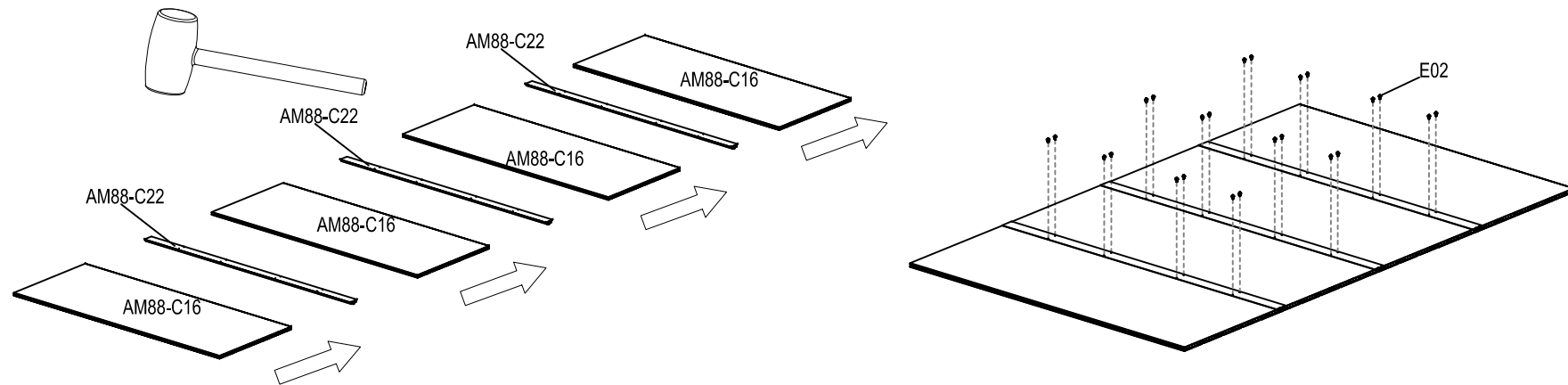

### Roof Pre-assembly Step

1. Connect the four panels together through the grooves on both sides of AM88-C22.
2. Use a rubber hammer or other means to make each face or edge of the assembled panel level and leave no gaps.
3. Use screws to fix the panel tightly.
4. Repeat twice.

AM88-A15 x 8

AM88-A16 x 4

AM88-A07 x 4

AM88-A08 x 2

AM88-A10 x 4

E08 x 28

E09 x 28

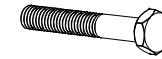
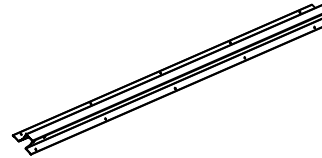

## Support frame Pre-assembly

K **x2**

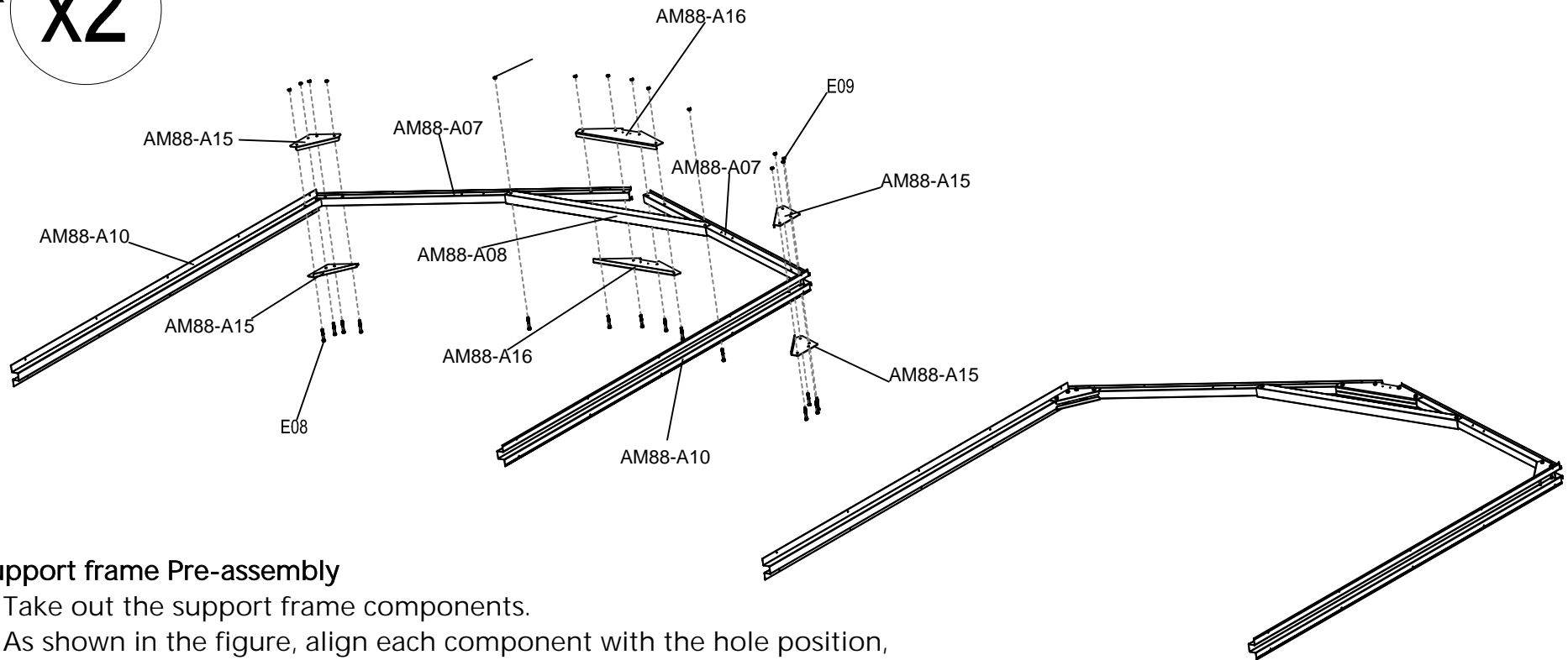

### Support frame Pre-assembly

1. Take out the support frame components.
2. As shown in the figure, align each component with the hole position, connect and fix it tightly with screws.
3. Repeat twice.

F35-C27 x 4

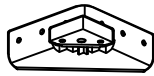

A64-C30 x 4

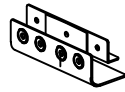

AM1410-A11 x 6



AM88-A24 x 2



E02 x 46



A x 1

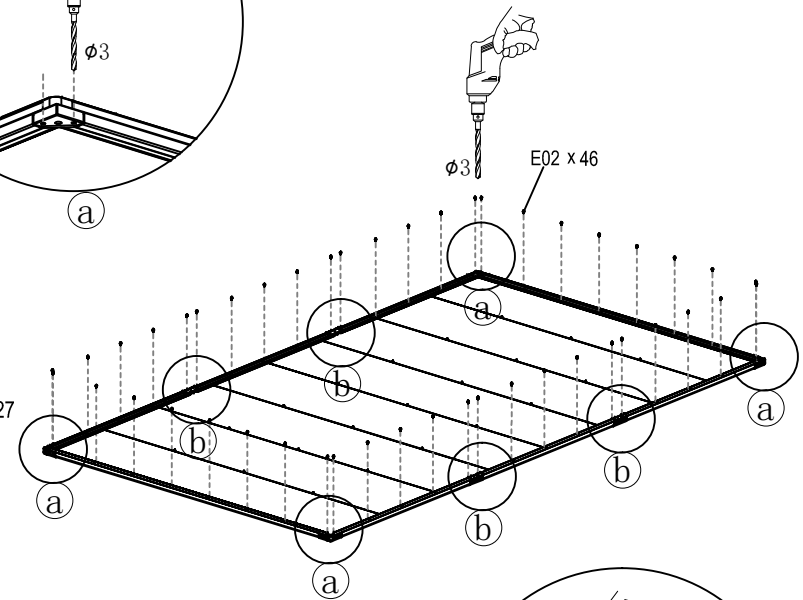
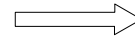
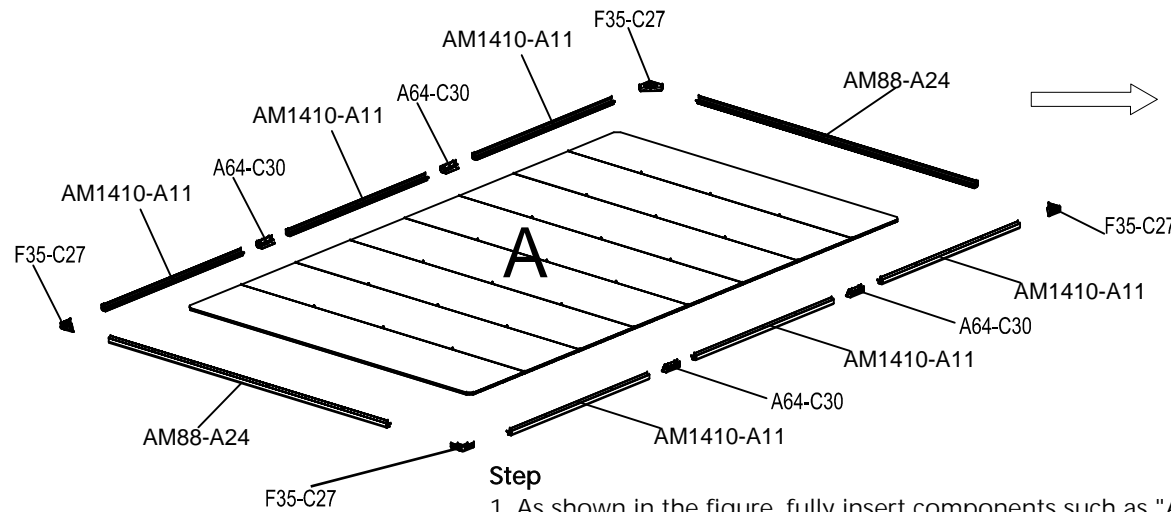
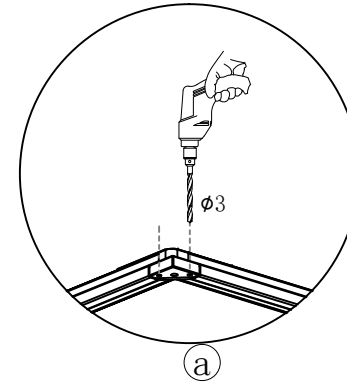
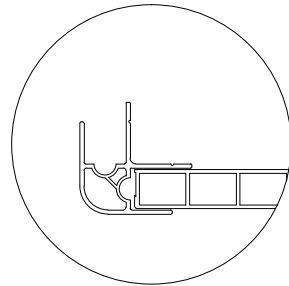
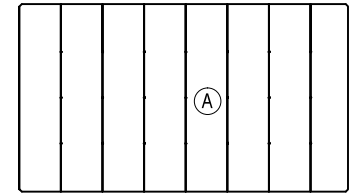

**Step**

1. As shown in the figure, fully insert components such as "AM1410-A11" into the edge of the bottom board.
2. Insert it piece by piece during installation, making it easier. Rubber hammer and scraper can be used to assist in installation.
3. After installation, each component needs to be tightly connected.
4. Fix the connection between the component and the base plate with screws.
5. Some holes are not pre drilled and can be forcefully drilled with an electric drill; Or drill a lead hole with an electric drill.

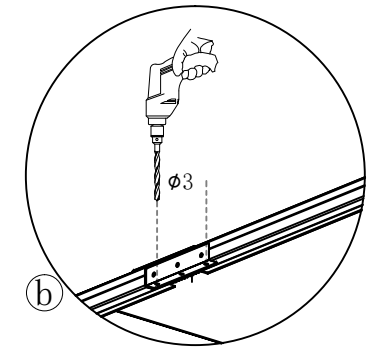

E04 x 8

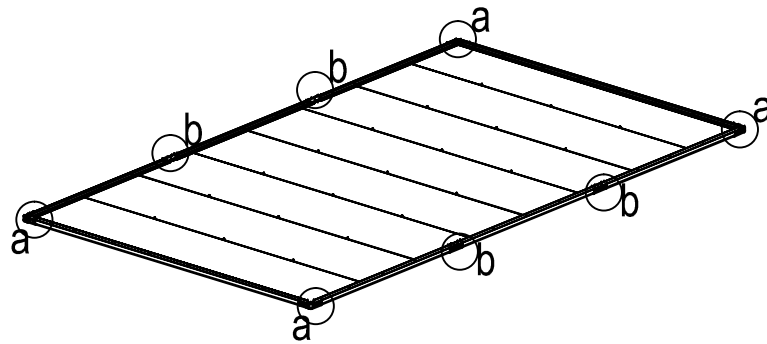
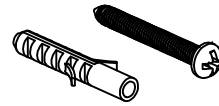

**Steps:**

1. On solid ground, the wind resistance of the house can be increased by adding ground anchors.
2. Use an electric drill to pre drill a hole in the corners and middle as shown in the picture.
3. Screw the expansion plug and long nail into the hole.

**NOTE:** Due to the large and heavy size of the house, it is difficult to move. If you want to install a ground anchor, it is best to proceed with this step

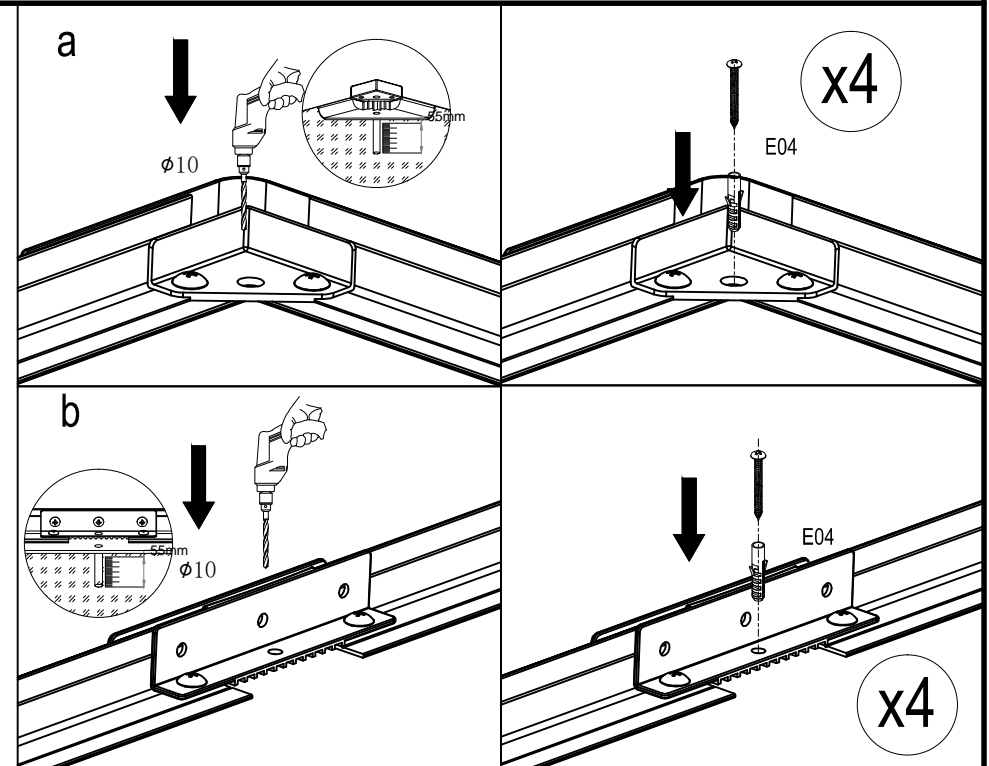

AM88-A22x 1

B x 1

C x 1

E02 x 10

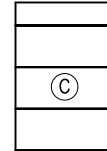
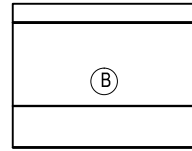

### STEP

1. Take out the assembled components "B" and "C".
2. Place and clip the side panel components into the grooves of the bottom panel separately.
3. Use your hands to stabilize the two side panels.
4. Insert the sliding grooves on both sides of "A86-C19" into the left and right side panels respectively, and slide them down from the top.
5. Use a rubber hammer or scraper to fully clamp the panel into the groove;  
Fully slide "A86-C19" onto the base plate.
6. Fix the connection with screws.

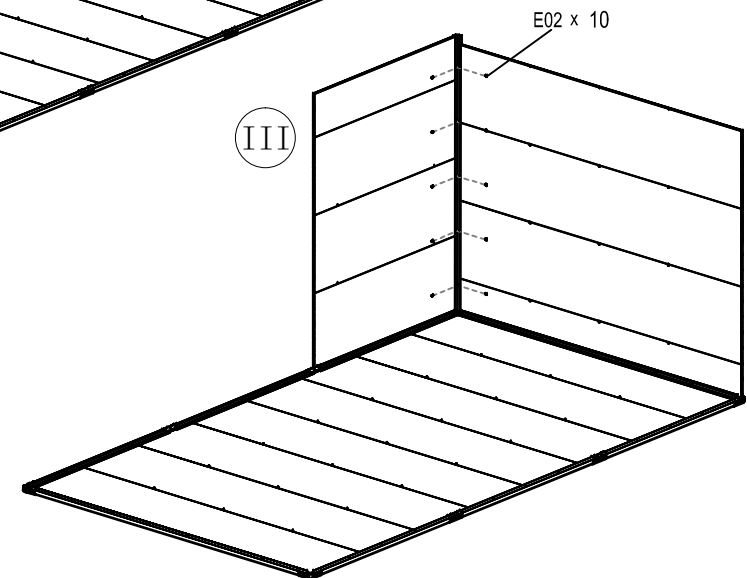
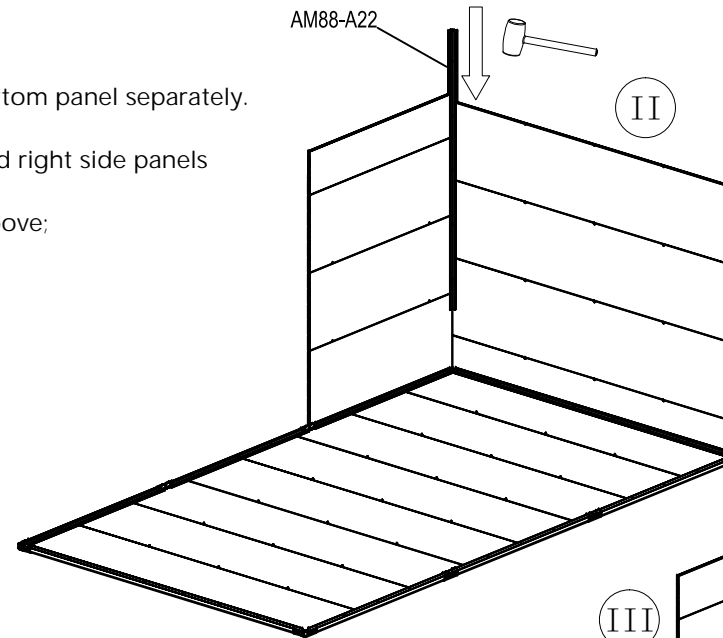
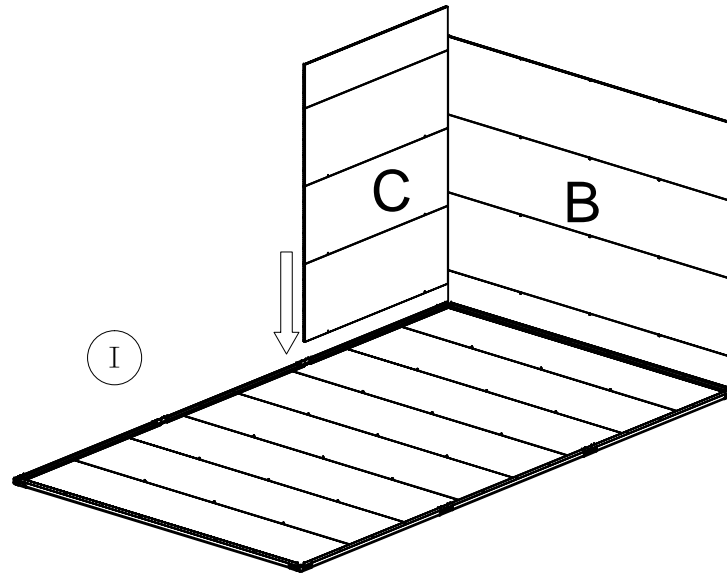

D x 1

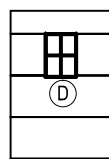

AM88-A25 x 1



E02 x 12

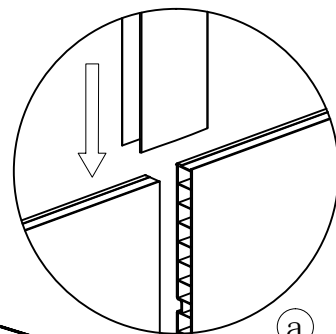

I

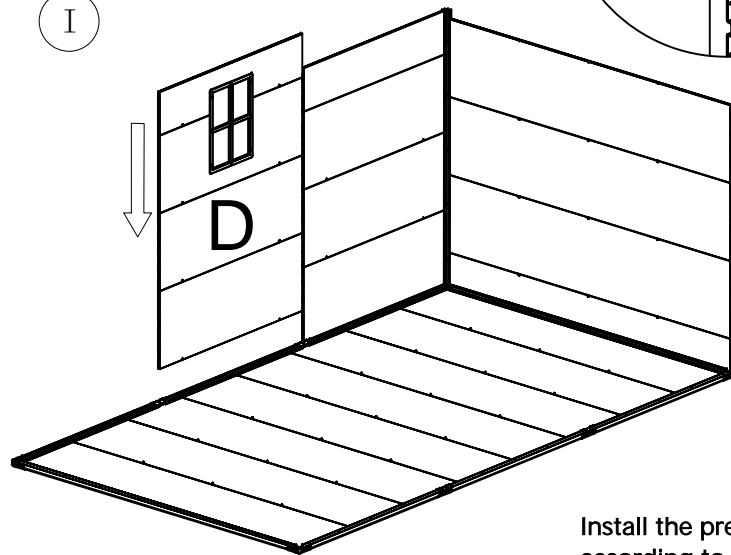

AM88-A25



II

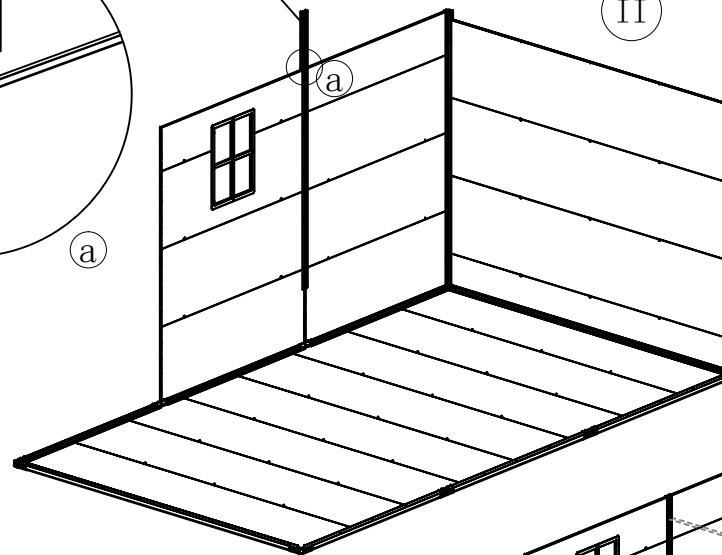

III

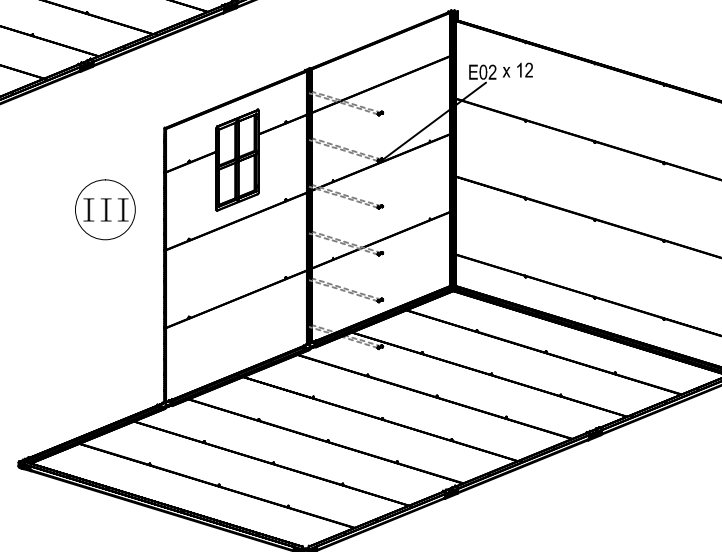

Install the pre installed components "D"  
according to the previous step.

E x 1

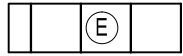

C x 1

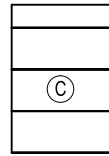

AM88-A22x 1



AM88-A25 x 1



E02 x 22

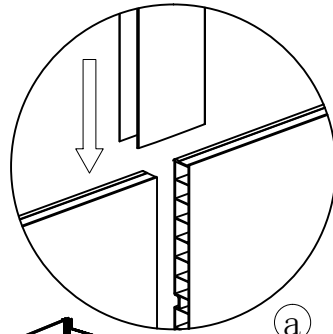

AM88-A22

AM88-A25

a

II

I

C

III

E02 x 22

Install the pre installed components "E"  
and "C" according to the previous step.

C x 1

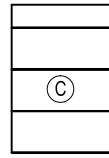

AM88-A22x 1



E02 x 10



I

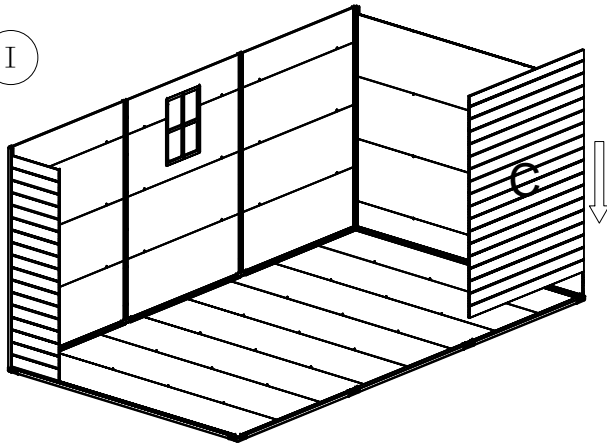

II

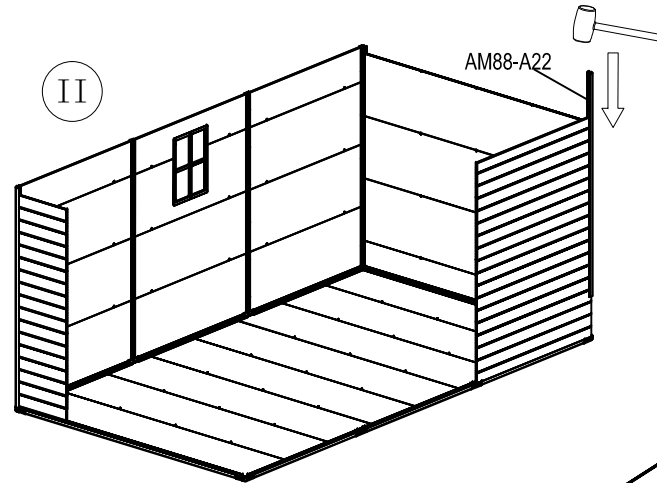

III

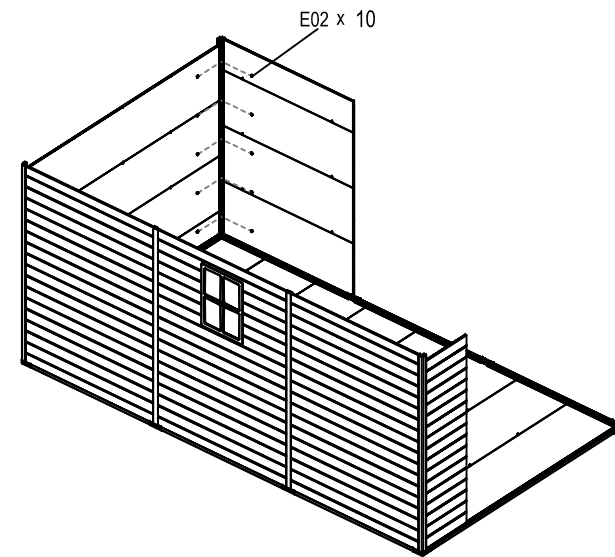

Install the pre installed components "C" according to the previous step.

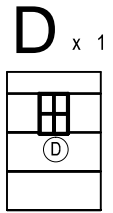

AM88-A25 x 1



E02 x 12

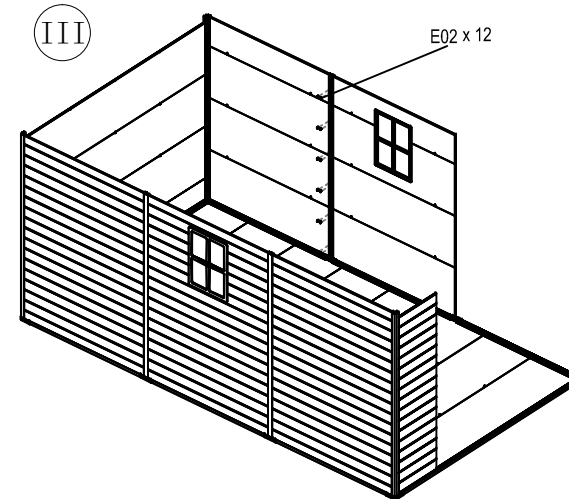
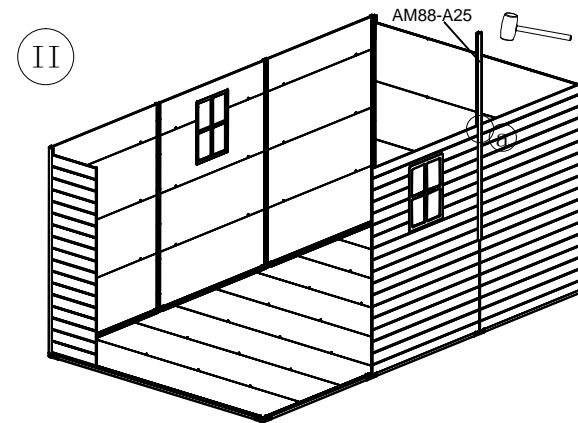
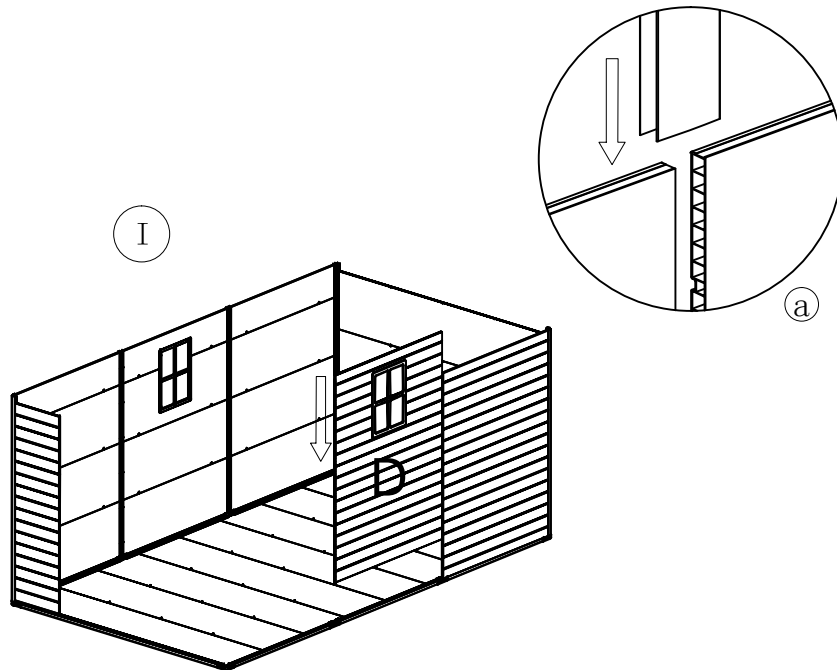

Install the pre installed components "D"  
"according to the previous step.

E x 1

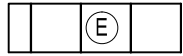

C x 1

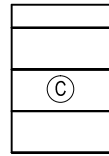

AM88-A22x 1



AM88-A25 x 1



E02 x 22



I

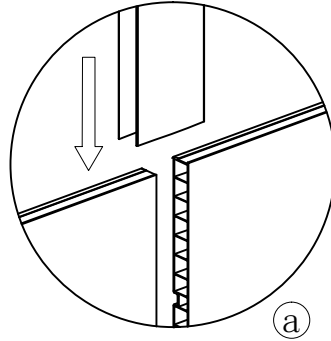
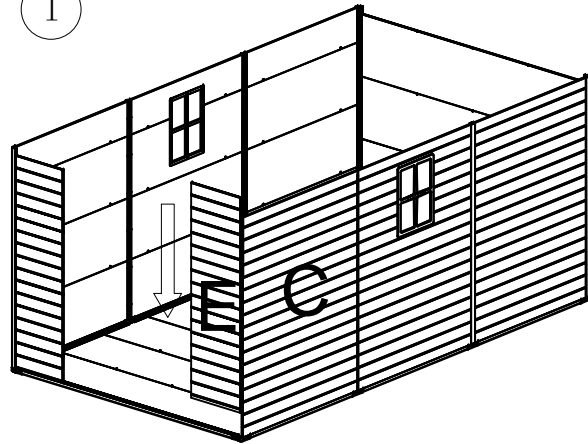

II

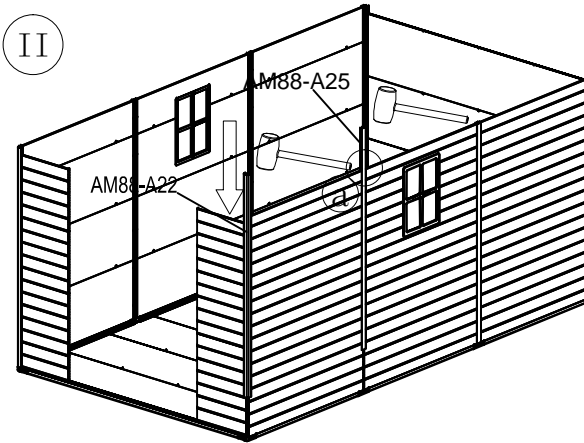

III

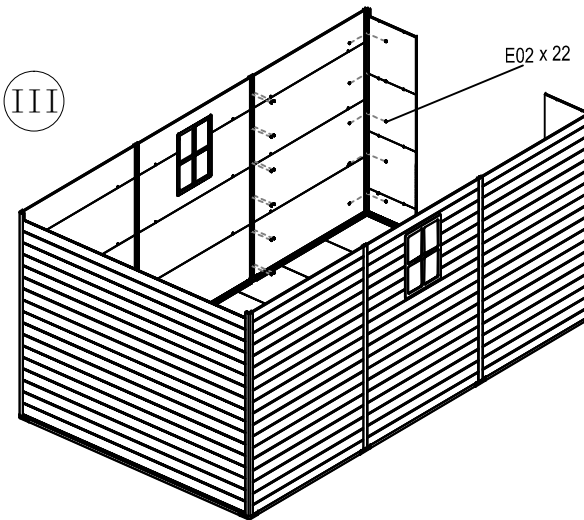

Install the pre installed components "E" and "C" according to the previous step.

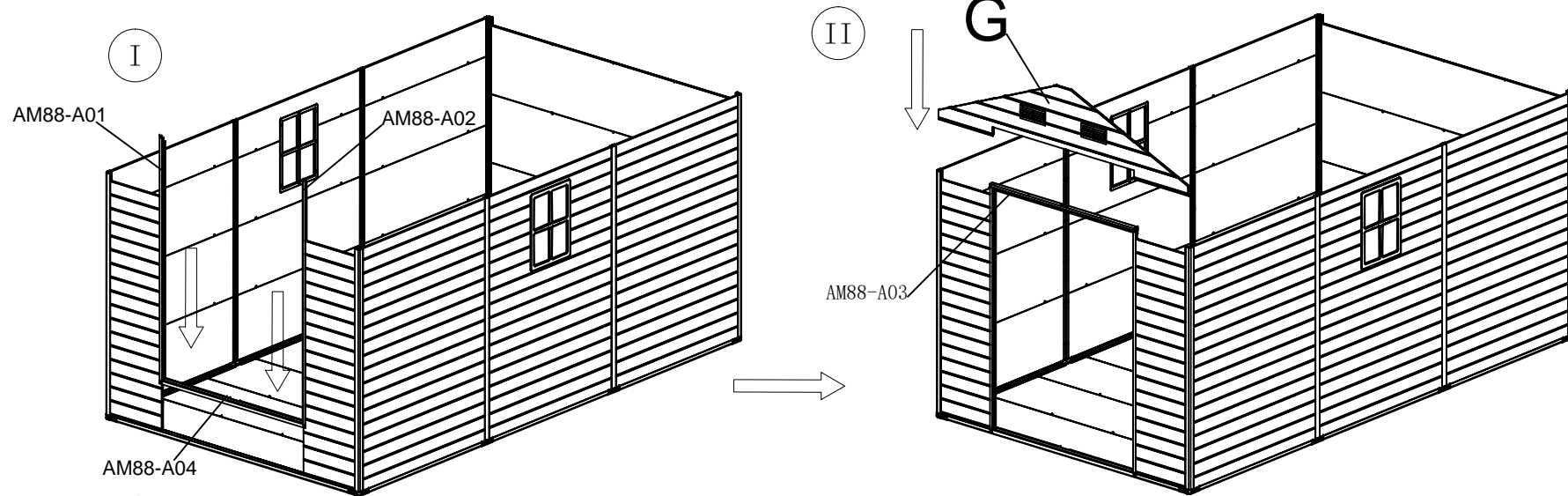
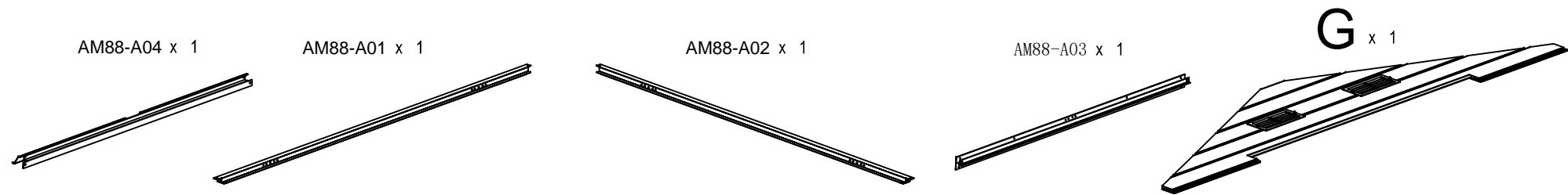

**Step :**

1. Take out the "AM88-A04" component and clip it onto the front door sill.
2. Align the grooves of "AM88-A01" and "A02" components with the edges of the front door panels on both sides, and slide them down from the top.
3. Use a rubber hammer or scraper to fully clamp the panel into the slot; Slide the component to the bottom and secure it onto "AM88-A04".
4. Take out "AM88-A03", Place it on the top of the front door and secure it.
5. Place the assembled "G" components on the top of the front door, and clamp them .

E02 x 59

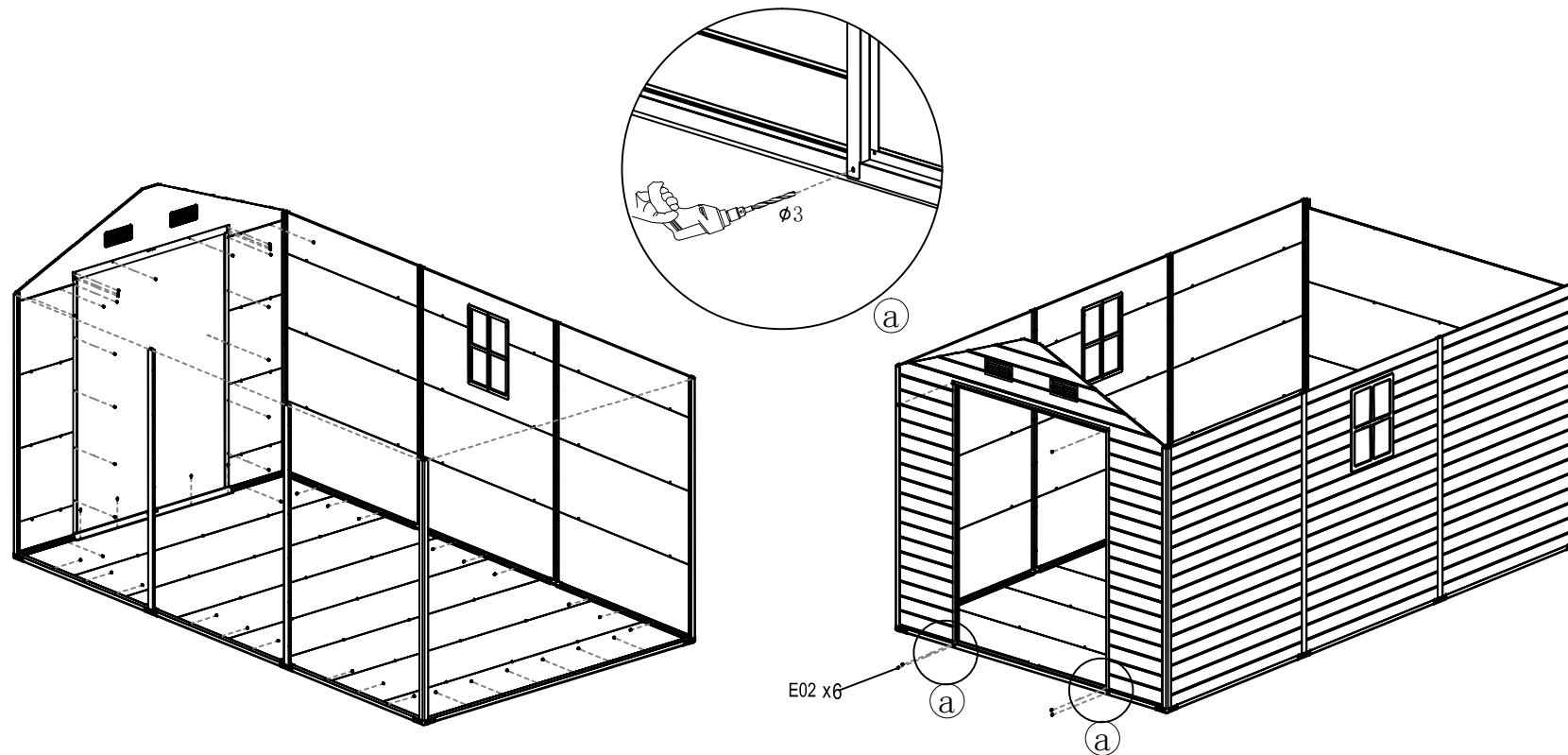

**Step**

1.As shown in the figure, fix it with screws.

**Note:** When fixing the bottom, only one panel of the metal panel may have pre drilled holes, which require you to use considerable force to drill open; Or install a drill bit on the electric drill to drill a hole in advance.

F x 1

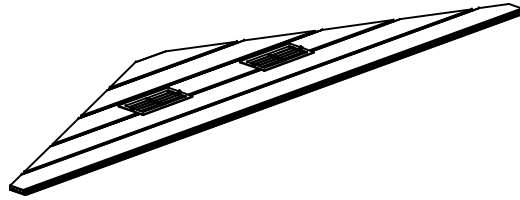

E02 x 3

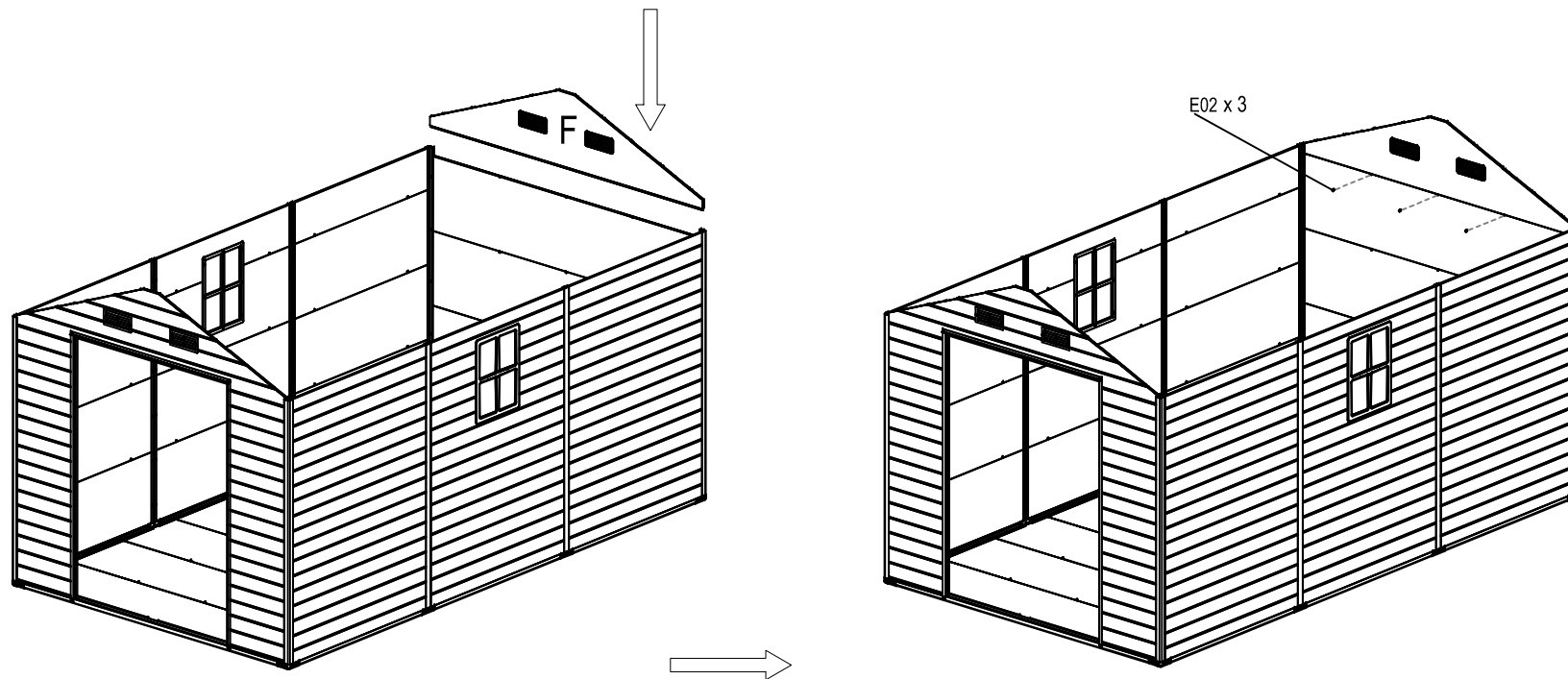

### Step

1. Place the assembled "F" components on the top of the back wall and clamp them .
2. Fix the panel connection with screws.

K x 2

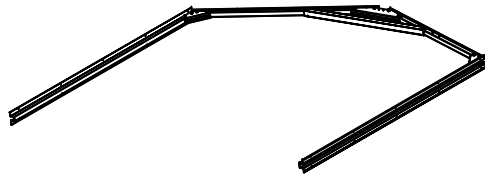

E02 x 32



**NOTE:** If there is a problem with the spacing between the installed support frames, it will make it difficult to connect the top iron parts in subsequent steps. You can first fix a small amount of screws to ensure that the support frames do not shake. After completing the final installation, fix all the screws at last

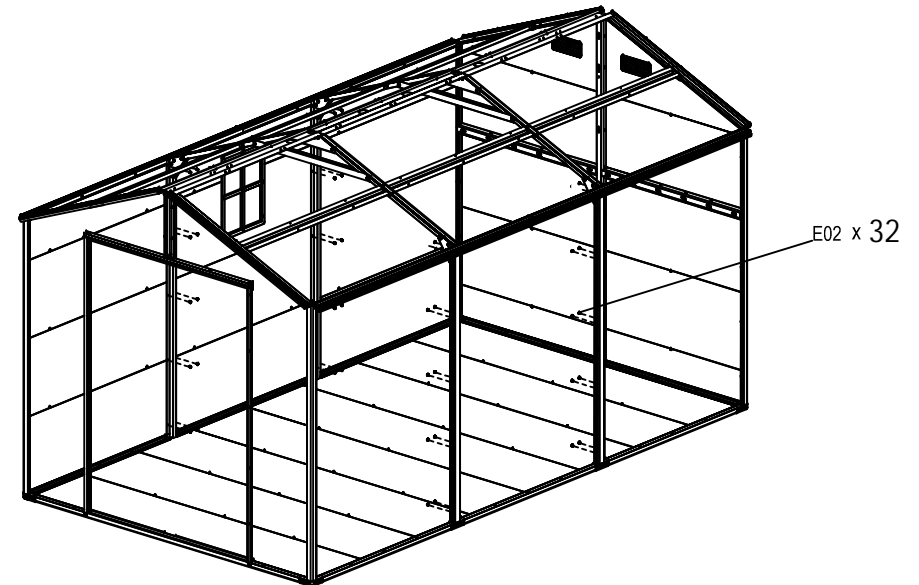
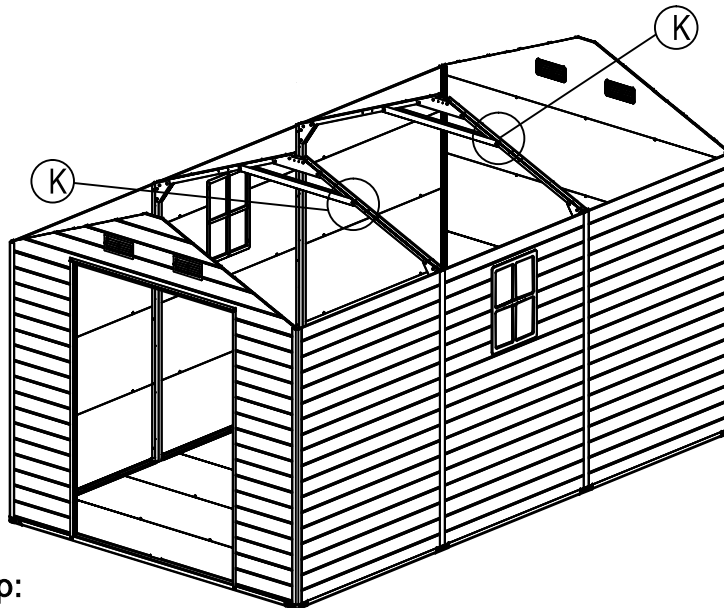

**Step:**

1. Lift the pre installed support bracket "K" and place it inside the house.
2. As shown in the figure, align the two sides of the support frame with the components at the connection between the left and right wall panels, so that their centerlines are consistent.
3. Use screws to support the holes on both sides of the bracket and connect and fix them to the left and right walls (Do not fix the top hole position for now).
4. Repeat twice.

AM1410-A03 x 2

AM1410-A04 x 1

E02 x 12

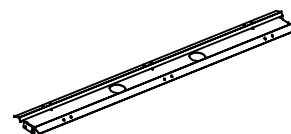
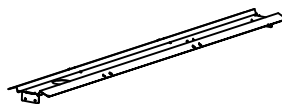

The large round hole faces the middle

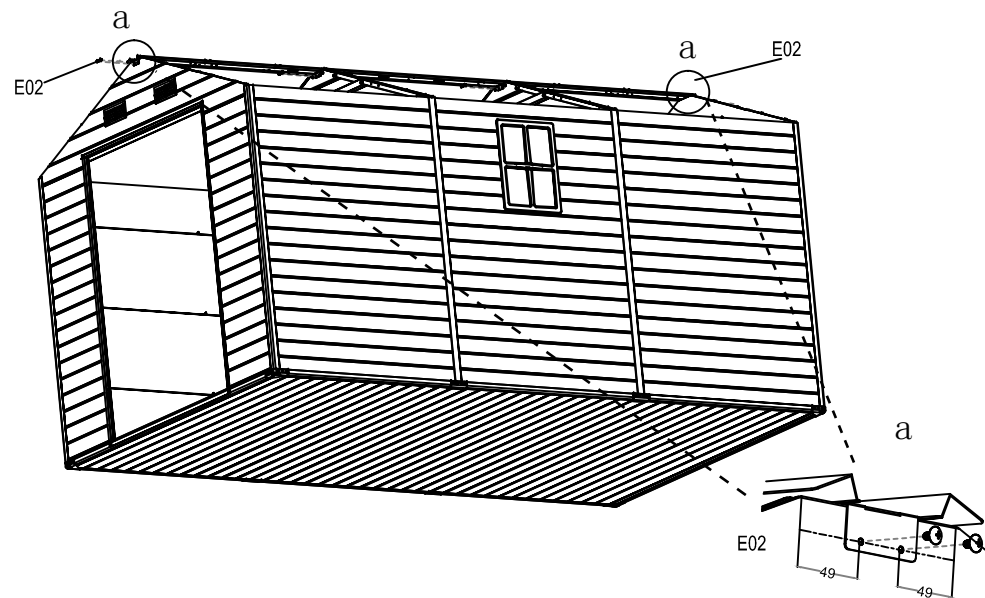
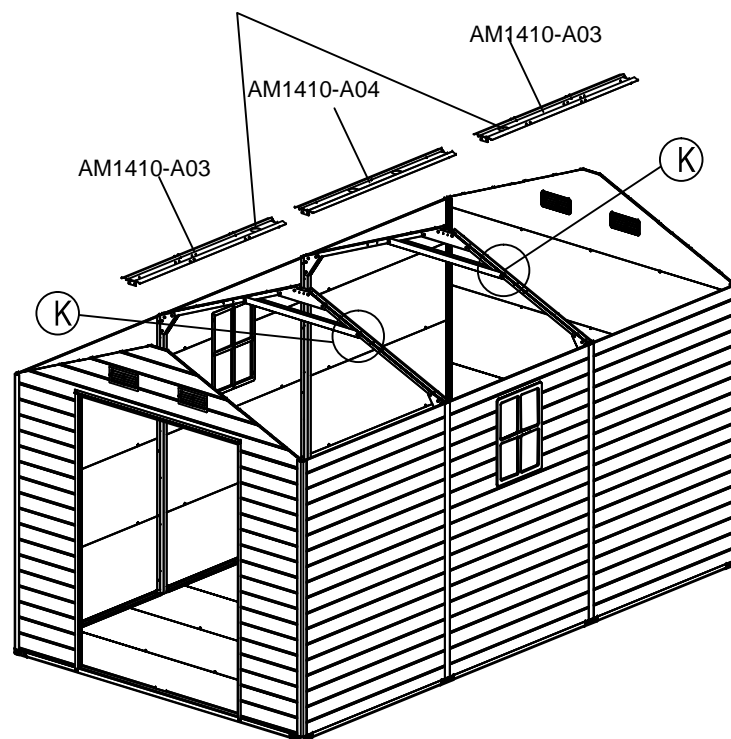

#### Step

1. Take out two "AM1410-A03" and adjust the direction so that the end closest to the large circular hole faces the inside of the house.
2. Lift up "AM1410-A03" and place one end on the top of the front or rear wall according to the direction.
3. As shown in Figure "a", place a protruding section of the edge of "AM1410-A03" on the outer side of the top of the front or rear wall, and fix it to the outer wall with screws
4. Align the other end of "AM1410-A03" with the pre drilled hole on the top of the support frame and fix it with screws.
5. Repeat twice.
6. Take out "AM1410-A04", align the holes at both ends with the pre drilled holes on the top of the two support frames, and fix them with screws.

AM1410-A05 x 4

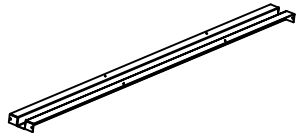

AM1410-A06 x 2

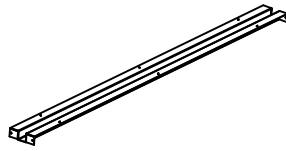

AM88-A14 x 4



E02 x 24



The large round hole faces the middle

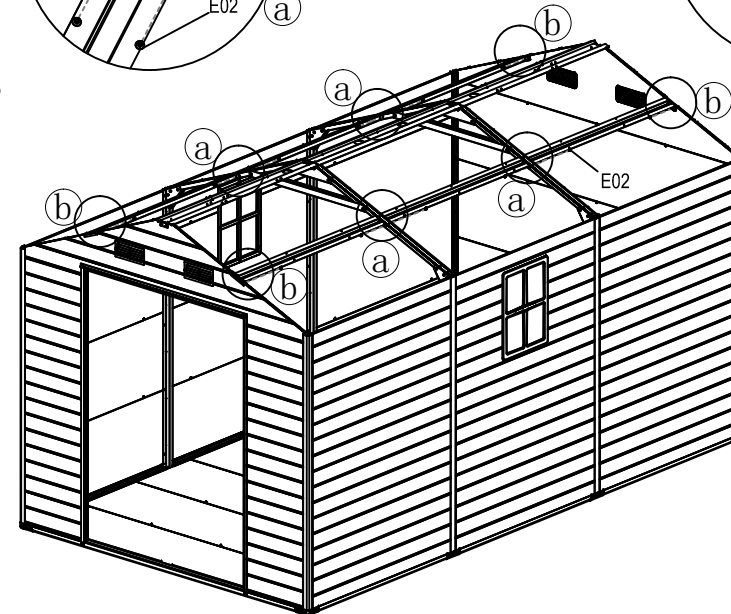
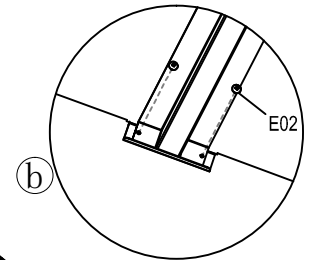
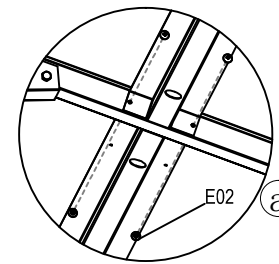
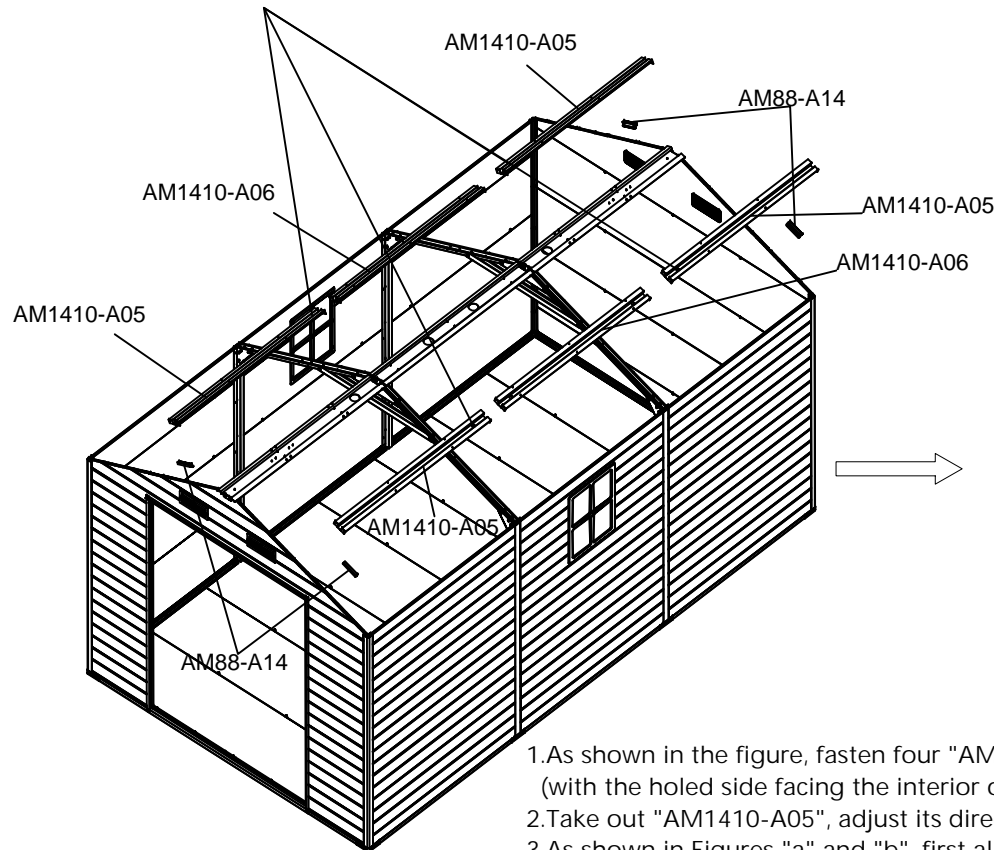

- 1.As shown in the figure, fasten four "AM88-A14" parts to the side walls at the top of the front and rear walls (with the holed side facing the interior of the house).
- 2.Take out "AM1410-A05", adjust its direction so that the end close to the large circular hole faces the inside of the house.
- 3.As shown in Figures "a" and "b", first align the end of "AM1410-A05" that is close to the support frame with the pre-drilled hole on the diagonal beam of the support frame, and fix it with screws.
- 4.Align the other end of "AM1410-A05" with the hole on "AM88-A14" and fix it with screws (the position of "AM88-A14" can be adjusted to make the connected diagonal beam straighter).
- 5.Repeat the above steps four times.
- 6.Take out "AM1410-A06", align the holes at both ends with the pre-drilled holes on the diagonal beams at the top of the two support frames respectively, and fix them with screws.
- 7.Repeat twice.

AM88-A05 x 1

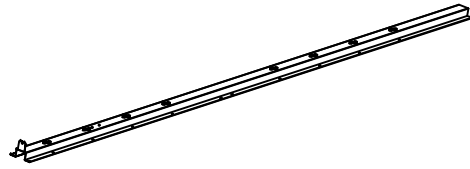

AM88-A06 x 2

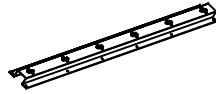

E02 x 40

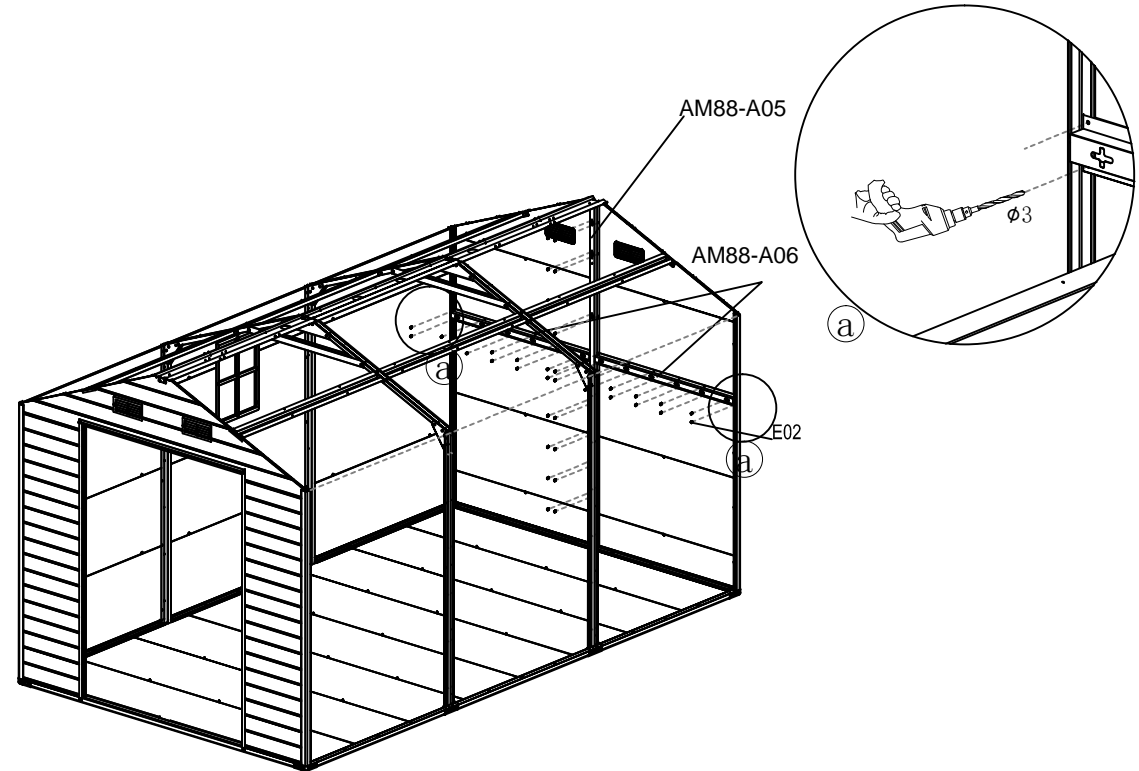
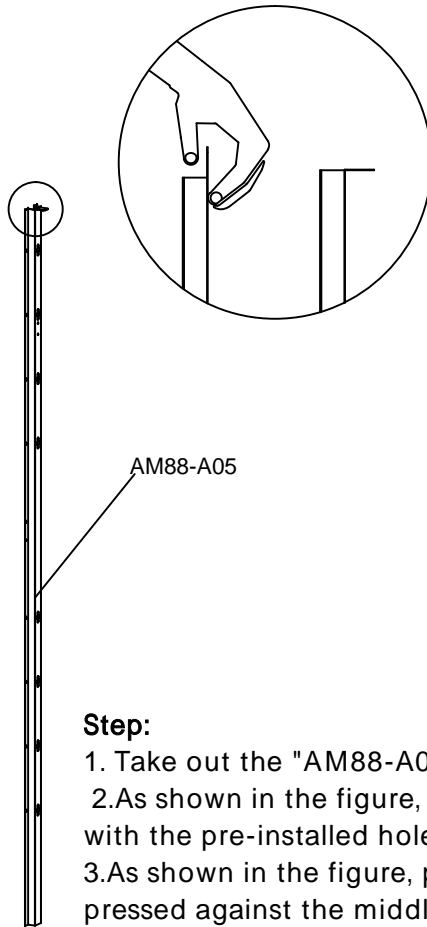

**Step:**

1. Take out the "AM88-A05" component, use your hand to bend the top metal piece outside at an angle of about "90" .
- 2.As shown in the figure, place "AM88-A05" vertically at the center line of the rear wall, then align the holes on the bent part with the pre-installed holes on the top crossbeam, and fix it with screws.
- 3.As shown in the figure, place two "AM88-06" parts horizontally on the joint of the rear wall panel, so that their two ends are pressed against the middle and left-right metal support rods.
- 4.Fix the parts and the panel with screws along the pre-installed holes.

**Note:** At the positions where the two sides of the left and right crossbars are pressed against the metal rods, there is only one pre-drilled hole, which needs to be drilled through with force; alternatively, use an electric drill to make a pilot hole.

AM88-A12 x 1

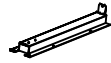

E02 x 6

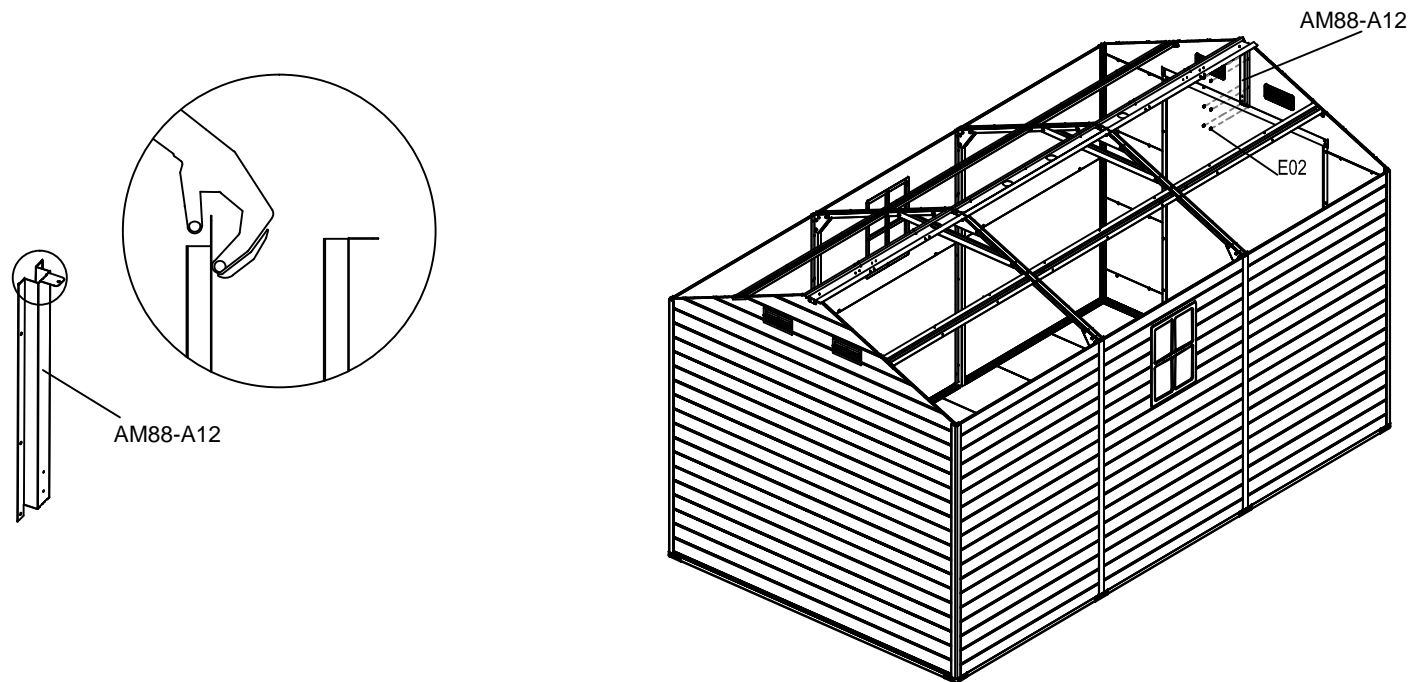

**Step:**

1. Take out the "AM88-A12" component, as shown in Figure , and use your hand to bend the top metal piece outside at an angle of about "90" .
- 2.As shown in the figure, align the bent end of "AM88-A12" with the pre-drilled hole on the crossbeam at the top of the front door.
- 3.Align the hole at the other end with the pre-installed hole on the door frame at the top of the front door.
- 4.Fix it with screws.

AM88-C18 x 4

AM148-C03 x 4

E02 x 28

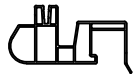

**Note:** AM88-C18, When clamping onto the rear wall, first extend it to the bottom of the roof beam, then clamp it onto the rafter.

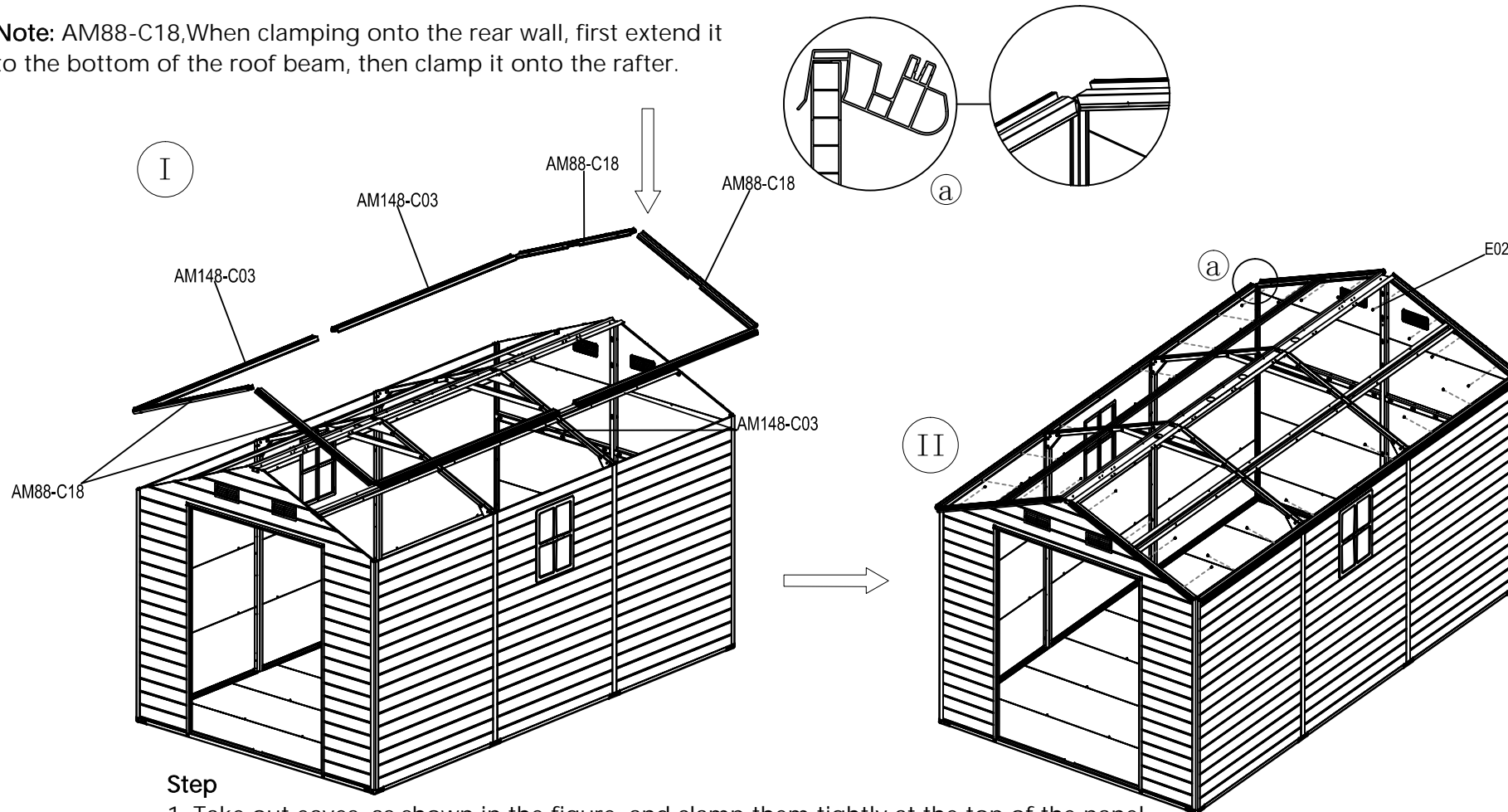

### Step

1. Take out eaves, as shown in the figure, and clamp them tightly at the top of the panel.
2. The protruding eaves face outward.
3. Use a rubber hammer or scraper to fully fit the panel with the groove.
4. Fix the connection position between the panel and the components with screws.

E02 x 40

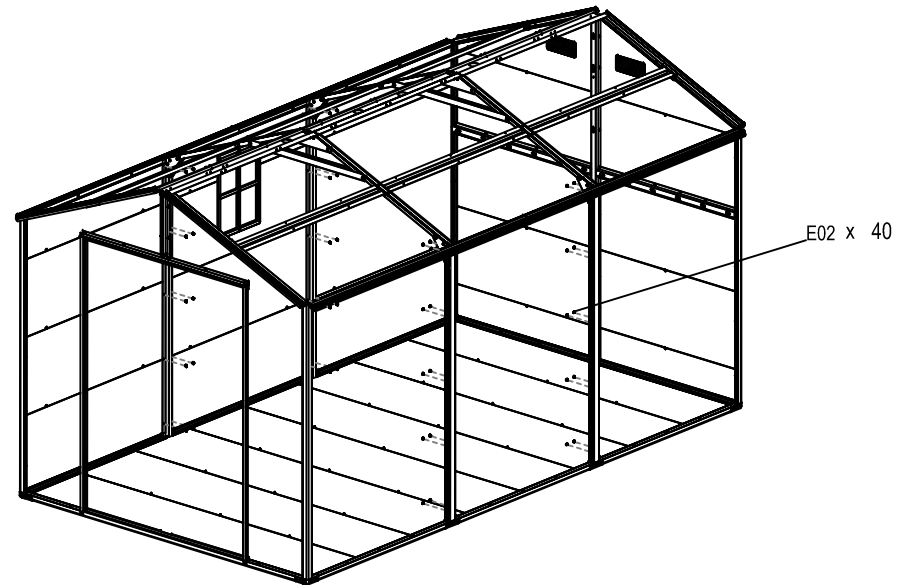

As shown in the picture, fully secure the support frame.

1 x 2

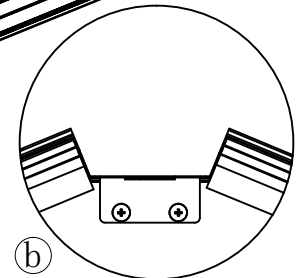
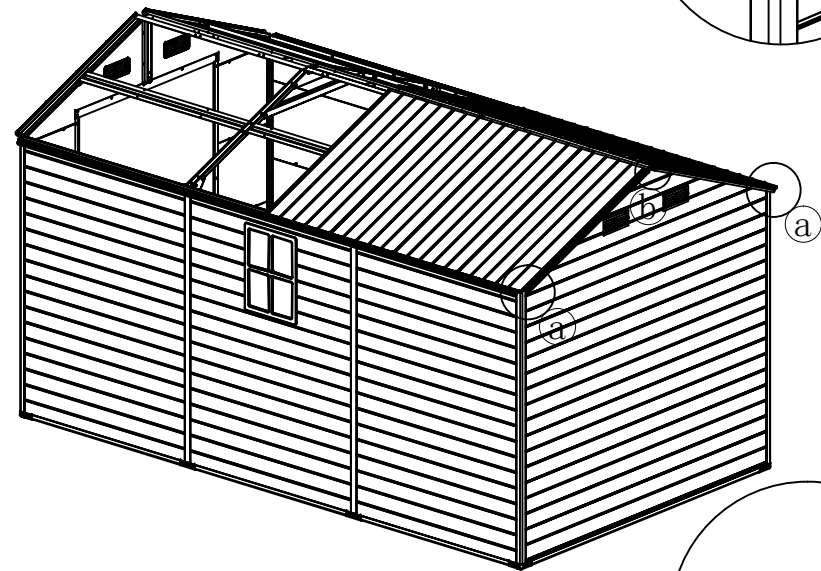
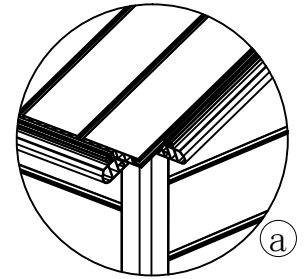
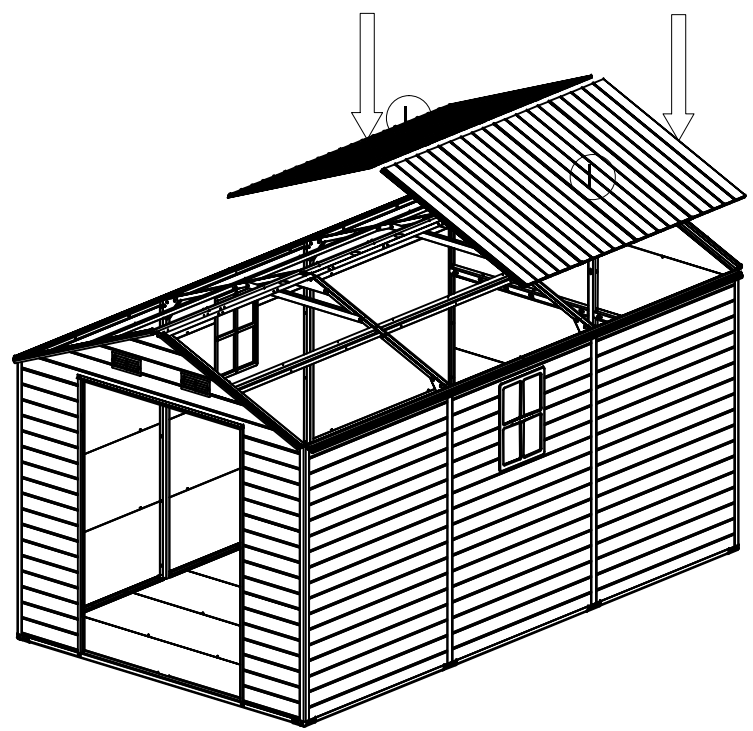
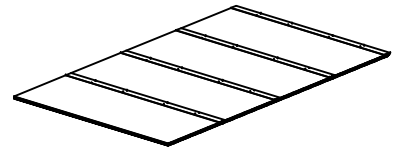

**Steps:**

1. Lift the assembled roof up
2. As shown in the picture, align the edge of the roof with the inside of the eaves.

AM88-C24 x 1



AM148-C02 x 1

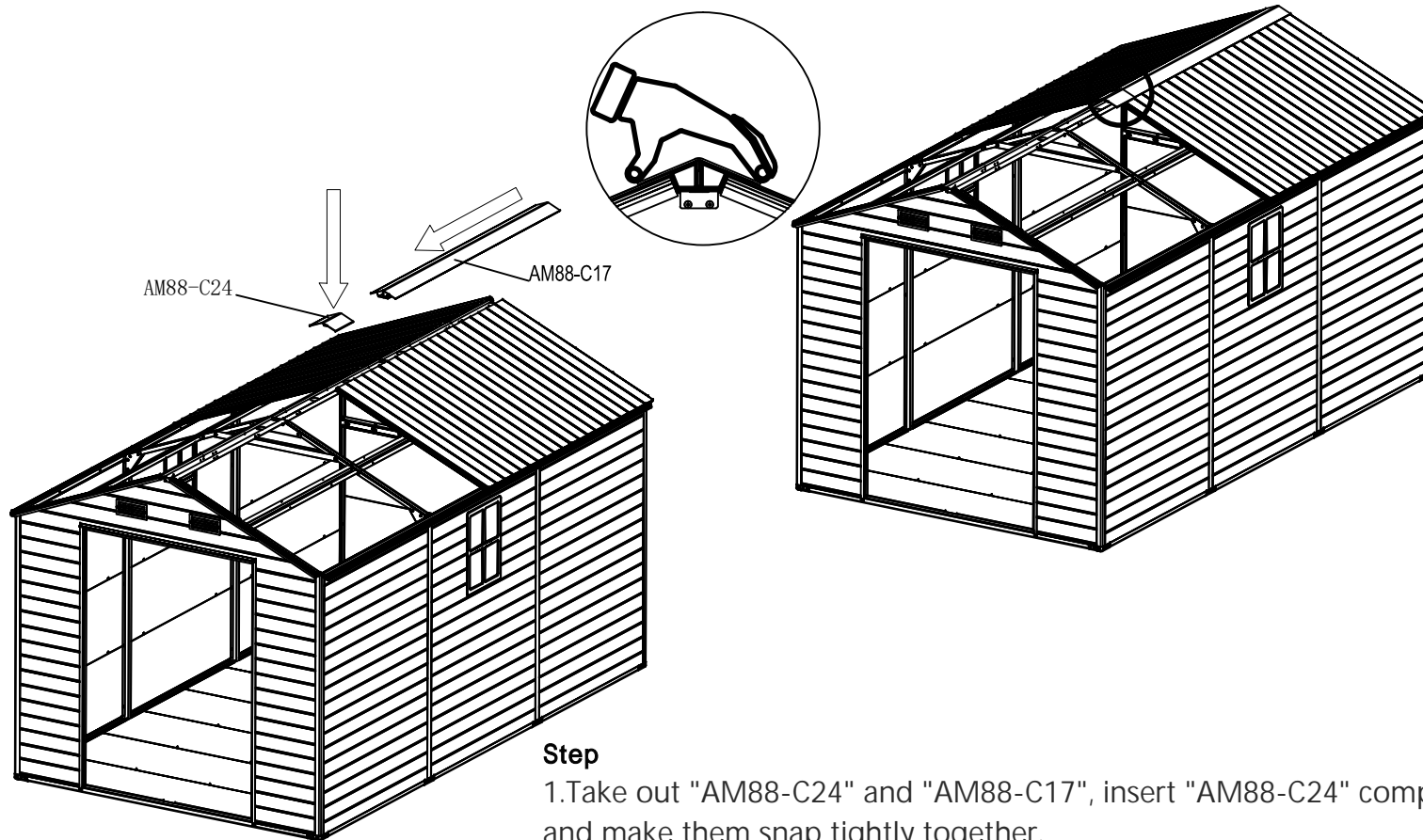

**Step**

1. Take out "AM88-C24" and "AM88-C17", insert "AM88-C24" completely into "AM88-C17", and make them snap tightly together.
2. Place the assembled component on the roof crossbeam as shown in the figure.
3. After placing it on the crossbeam, check that the side close to the external wall should protrude slightly outward to fully cover the crossbeam.

AM88-A13 x 1

E13 x 6

E02 x 29



### Step

1. Take out "AM88-A13", align its holes with the pre-drilled holes on the rear wall support frame and the crossbeam as shown in the figure, then fix it with screws. After fixing, it should form a triangular shape.

2. Start fixing the crossbeam, diagonal beam, and the roof together.

**Before fixing, press down on the roof to prevent it from being pushed up.**

3. Use long screws to fix the roof along the pre-drilled hole at the very center of the crossbeam.

4. Use short screws to fix the roof along the pre-drilled holes on the edge of the crossbeam.

5. Use short screws to fix the roof along the pre-drilled holes on the edge of the diagonal beam.

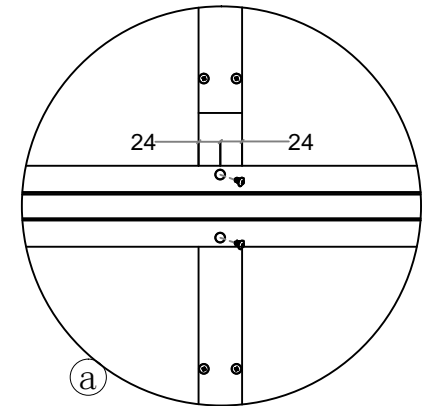

(a)

AM88-A13

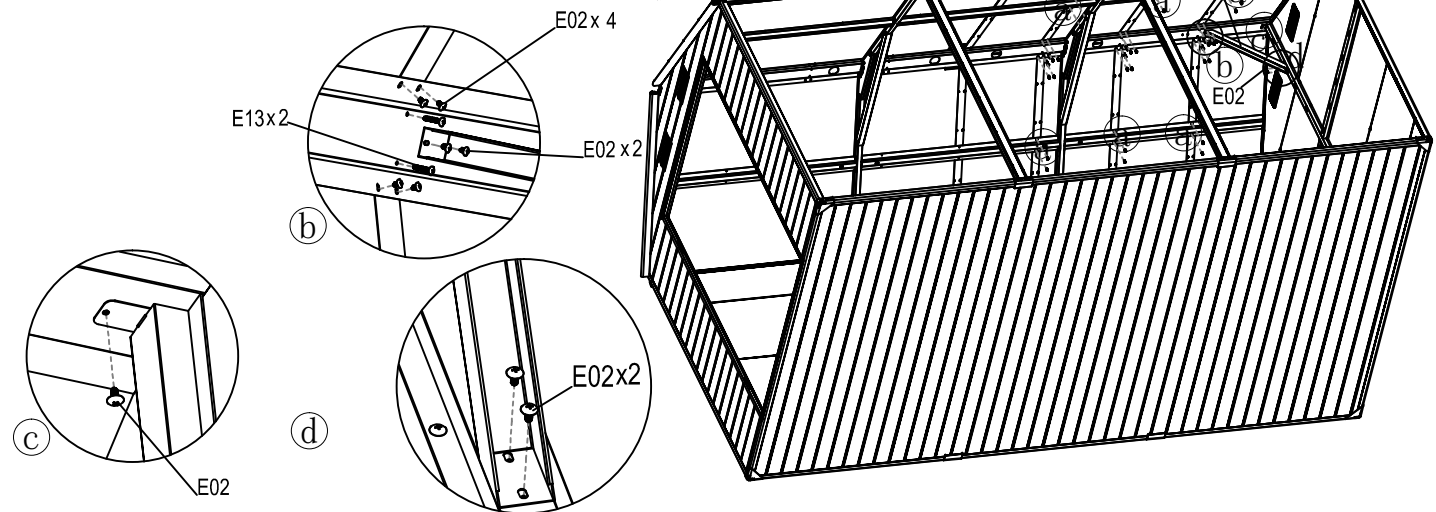

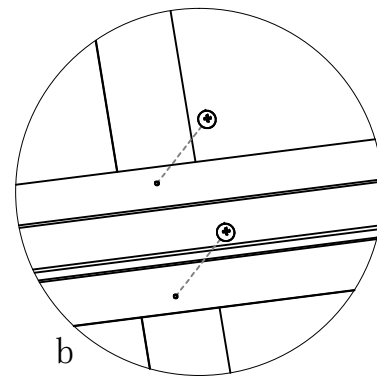
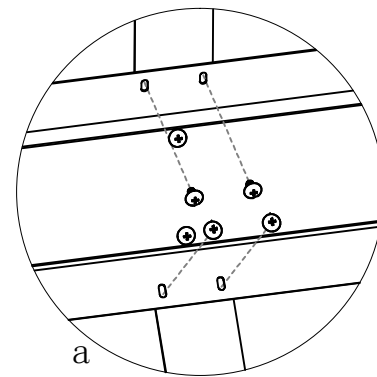
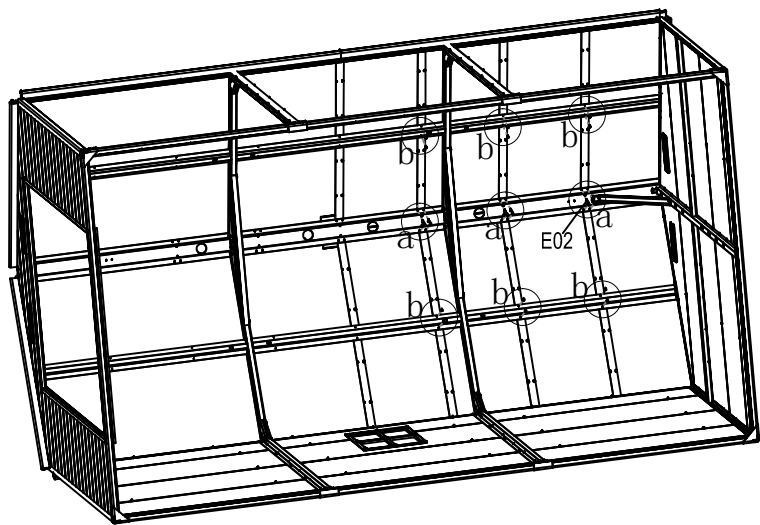

AM148-C02 x 1



E13 x 2

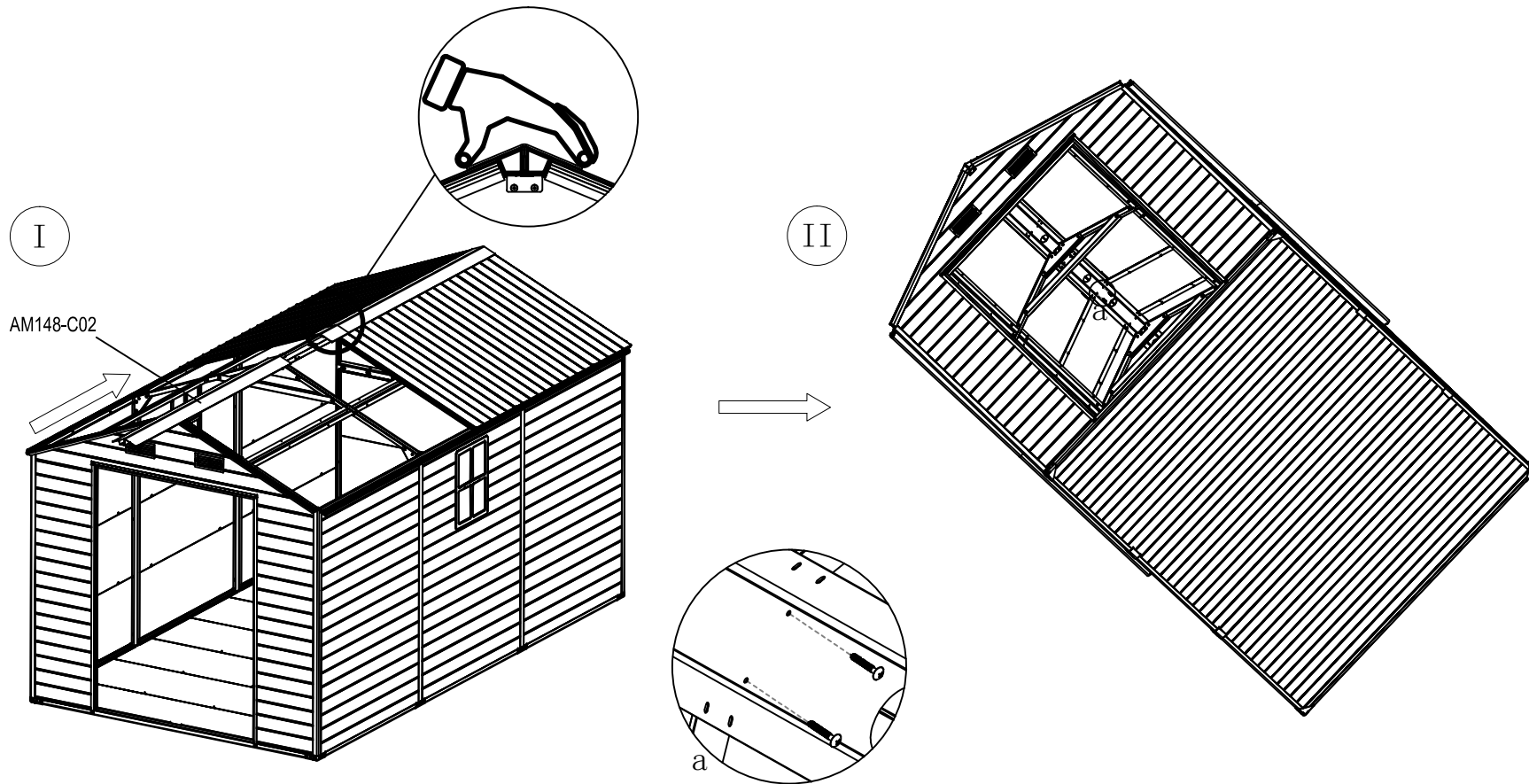

**Step**

1. Take out "AM148-C02", place it on the roof crossbeam as shown in the figure, then insert it completely into "AM88-C24" to make them snap tightly together.
2. Fix the joint with long screws.

J x 2

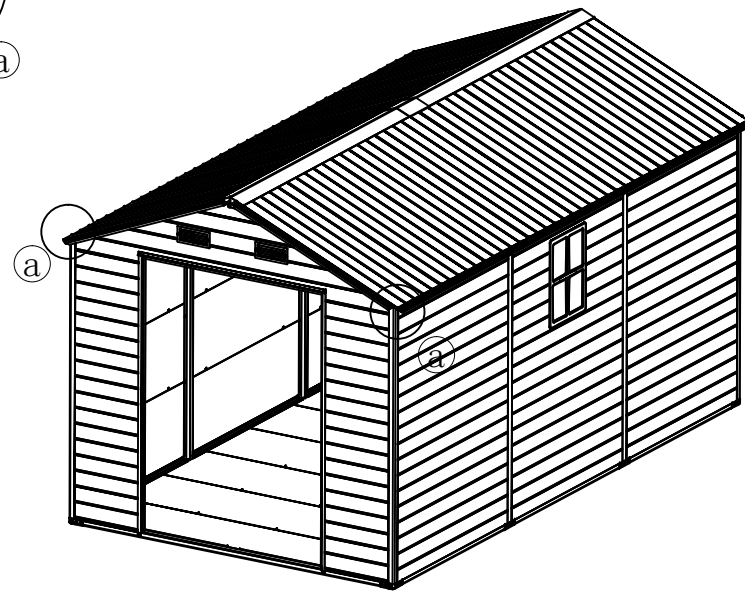
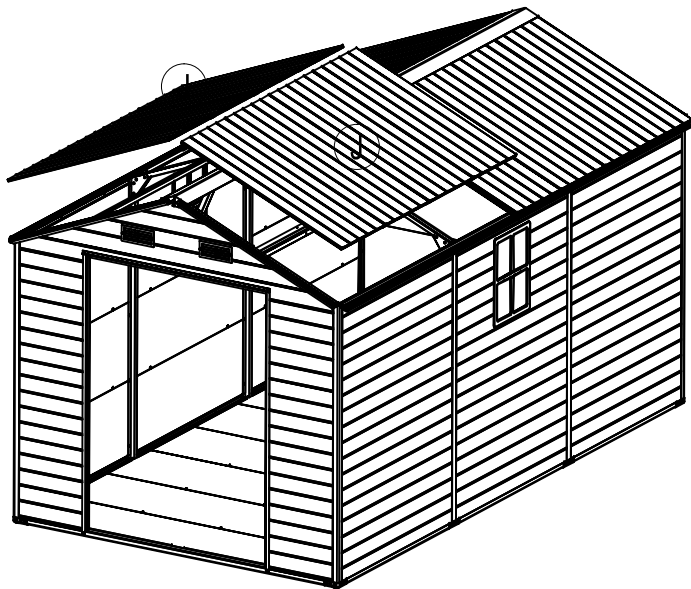
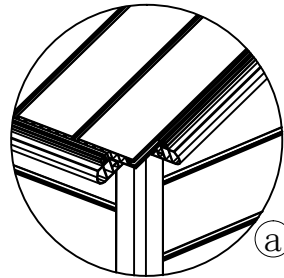
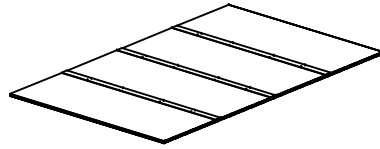

**Steps:**

1. Lift the assembled roof up
2. As shown in the picture, align the edge of the roof with the inside of the eaves.

AM88-A13 x 1

E02 x 45

E13 x 6



### Step

1. Take out "AM88-A13", align its holes with the pre-drilled holes on the front wall support frame and the crossbeam, then fix it with screws. After fixing, it should form a triangular shape.

2. Start fixing the crossbeam, diagonal beam, and the roof together.

**Before fixing, press down on the roof to prevent it from being pushed up.**

3. Use long screws to fix the roof along the pre-drilled hole at the very center of the crossbeam.

4. Use short screws to fix the roof along the pre-drilled holes on the edge of the crossbeam.

5. Use short screws to fix the roof along the pre-drilled holes on the edge of the diagonal beam.

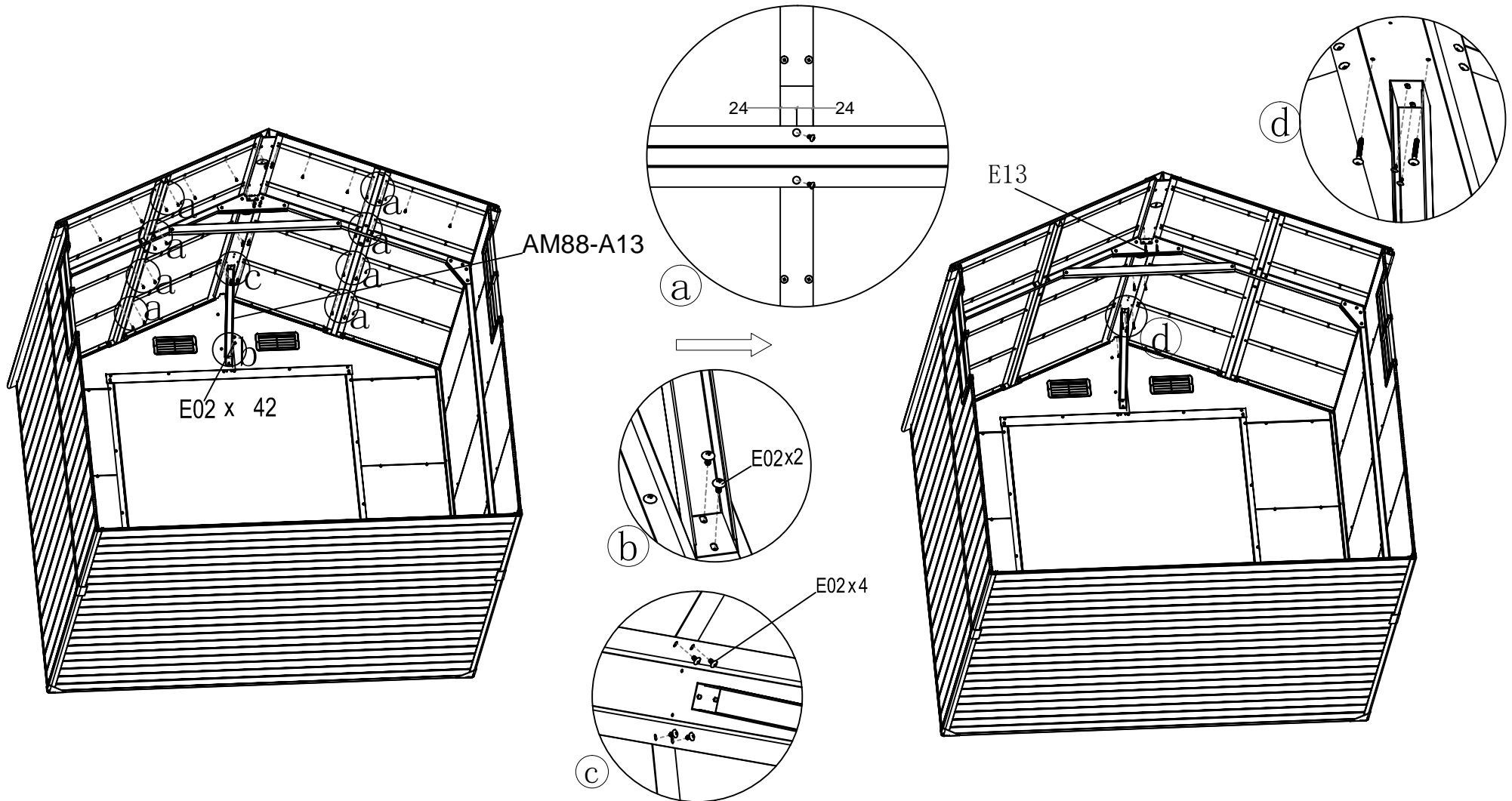

AM88-C20 x 4

AM148-C04x 4

E02 x 24

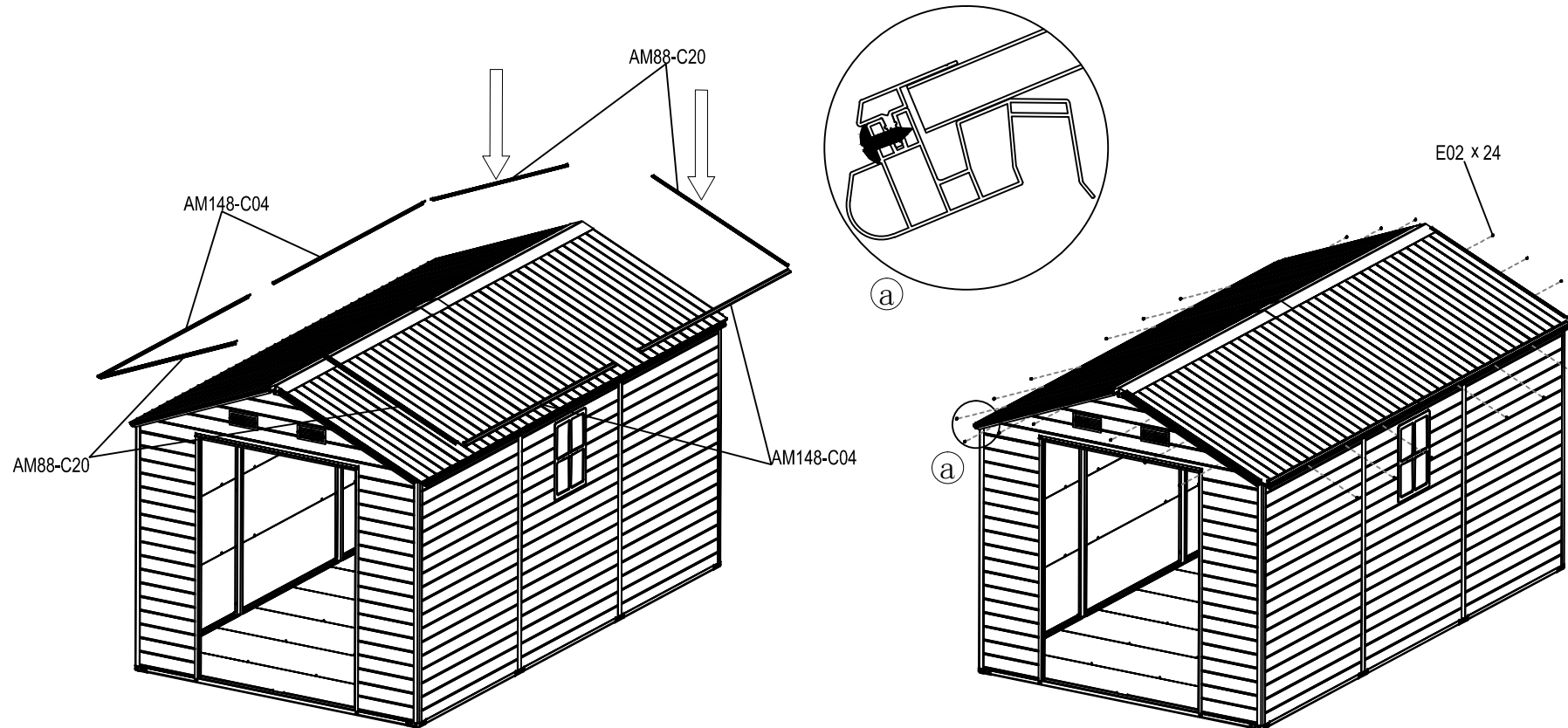

**Steps:**

1. Take out the sealing strips AM88-C20 and AM148-C04
2. As shown in figure (a), clamp the protruding part of the sealing strip into the groove at the top of the eaves, and press the top cover of the sealing strip onto the roof panel.
3. The installed sealing strip should be kept level with the eaves.
4. Use screws to fix the connection between the sealing strip and the eaves, as shown in Figure (a).

A64-C29 x 2

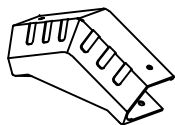

A812-C26 x 2

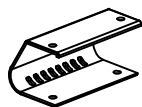

F35-C30 x 4



E02 x 32

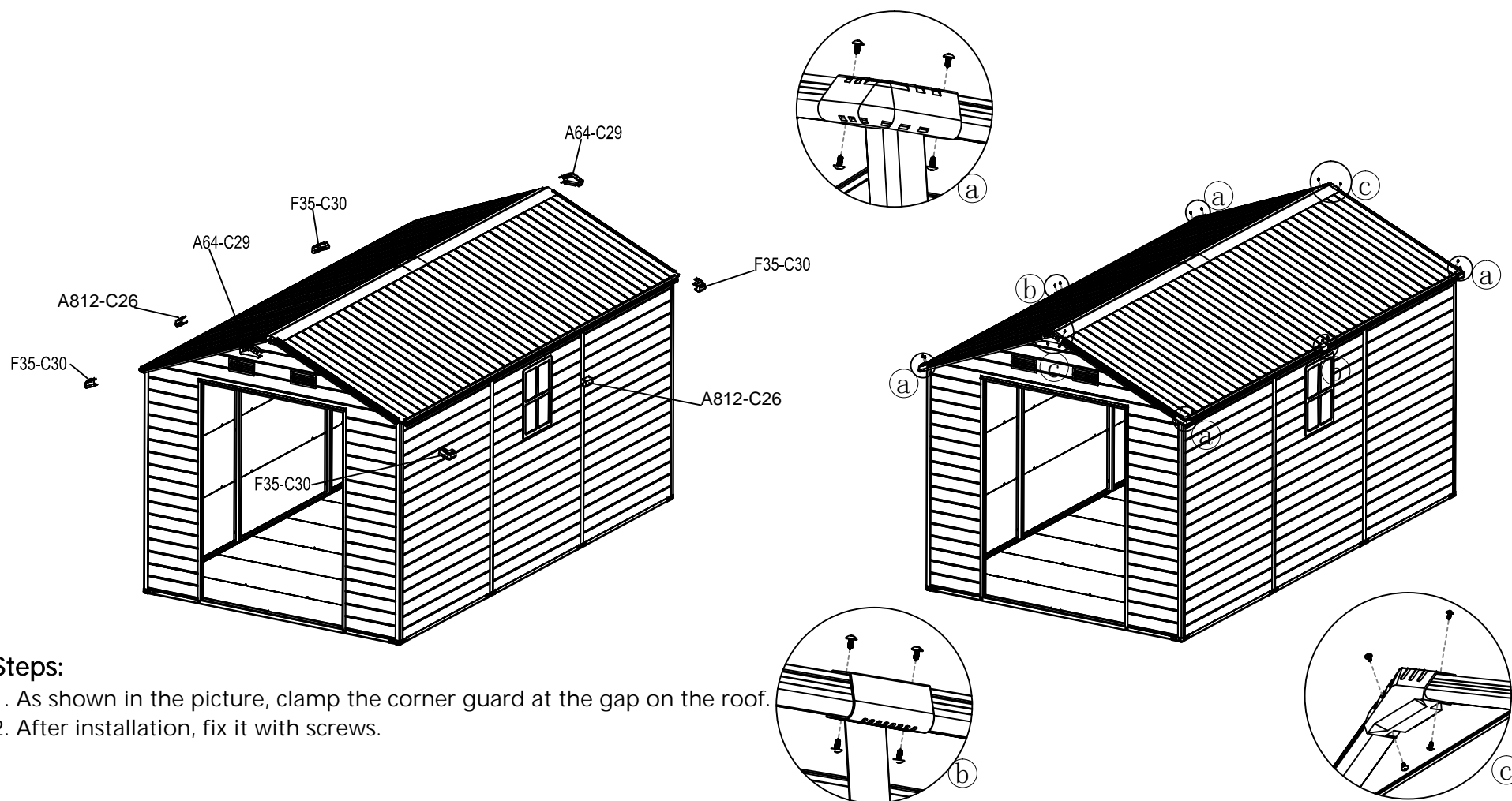

**Steps:**

1. As shown in the picture, clamp the corner guard at the gap on the roof.
2. After installation, fix it with screws.

L1 x 1

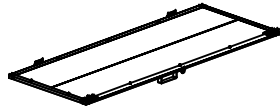

L2 x 1

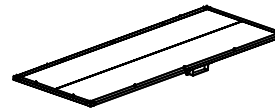

E12 x 12



### Step

1. Take out the pre installed front door, align the hinges with the holes on the door frame, and fix them with screws.

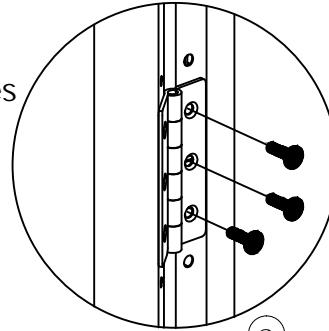

a

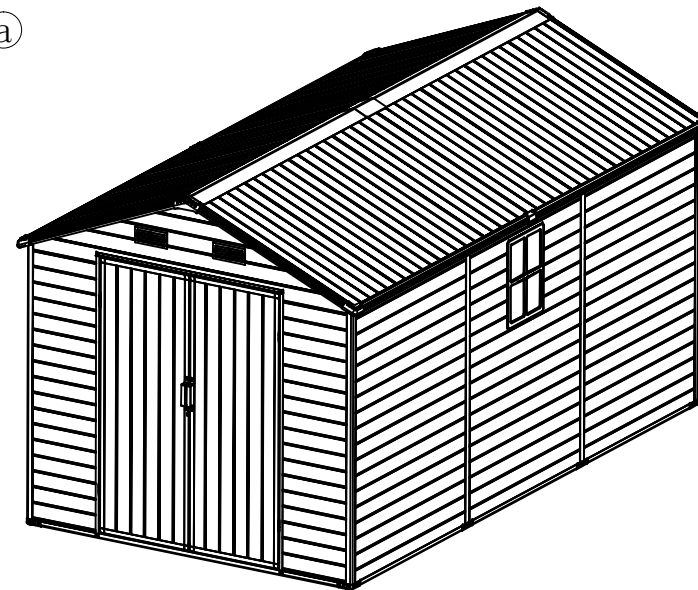
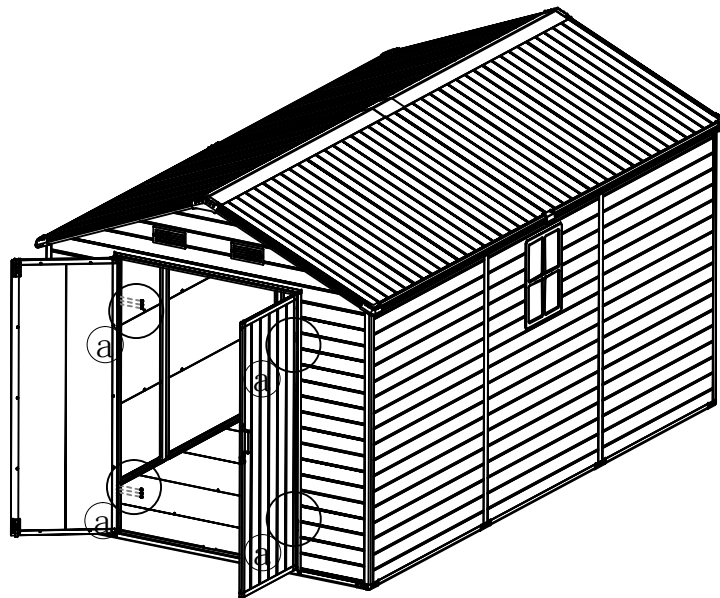

E03 x 40

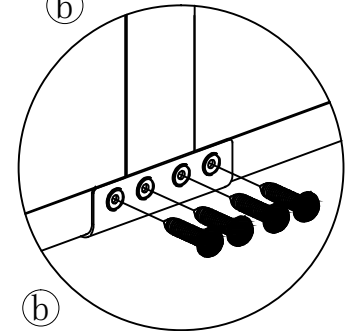
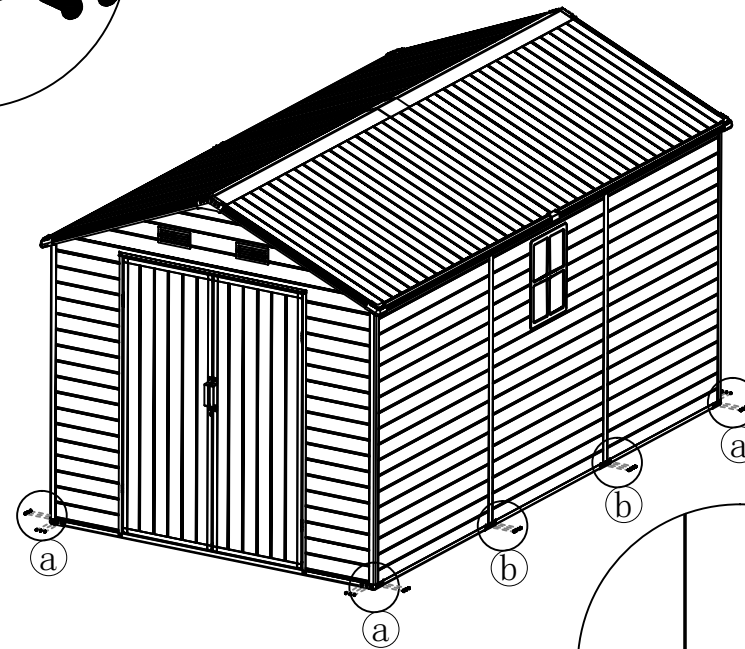
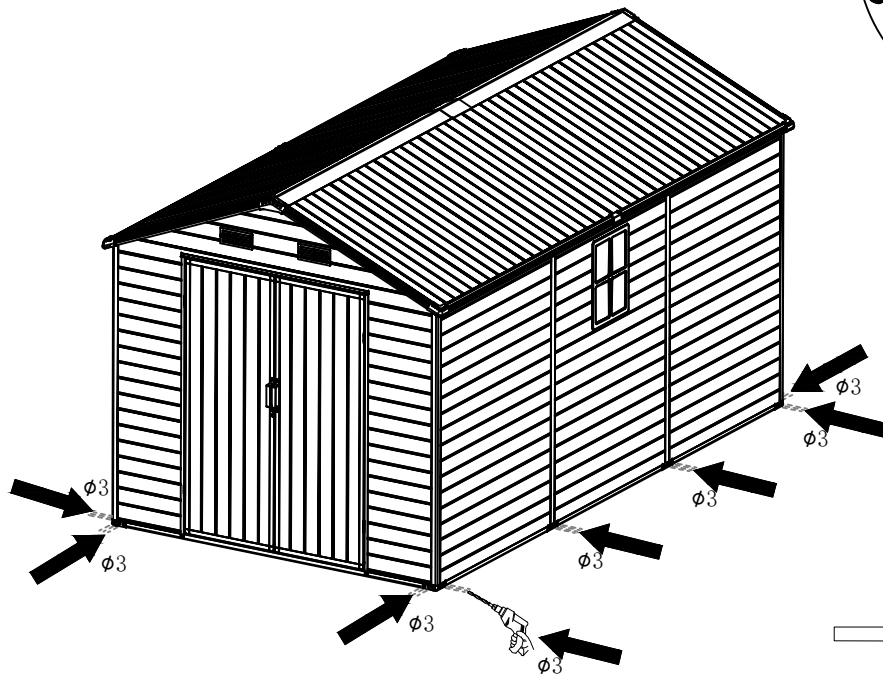
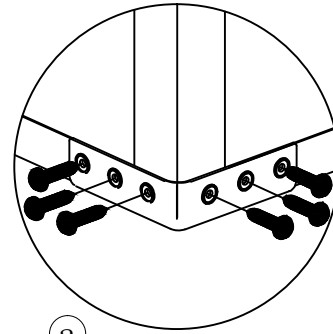

**Note:** When fixing the bottom, only one panel of the metal panel may have pre drilled holes, which require you to use considerable force to drill open; Or install a drill bit on the electric drill to drill a hole in advance.