

Assembly Instruction

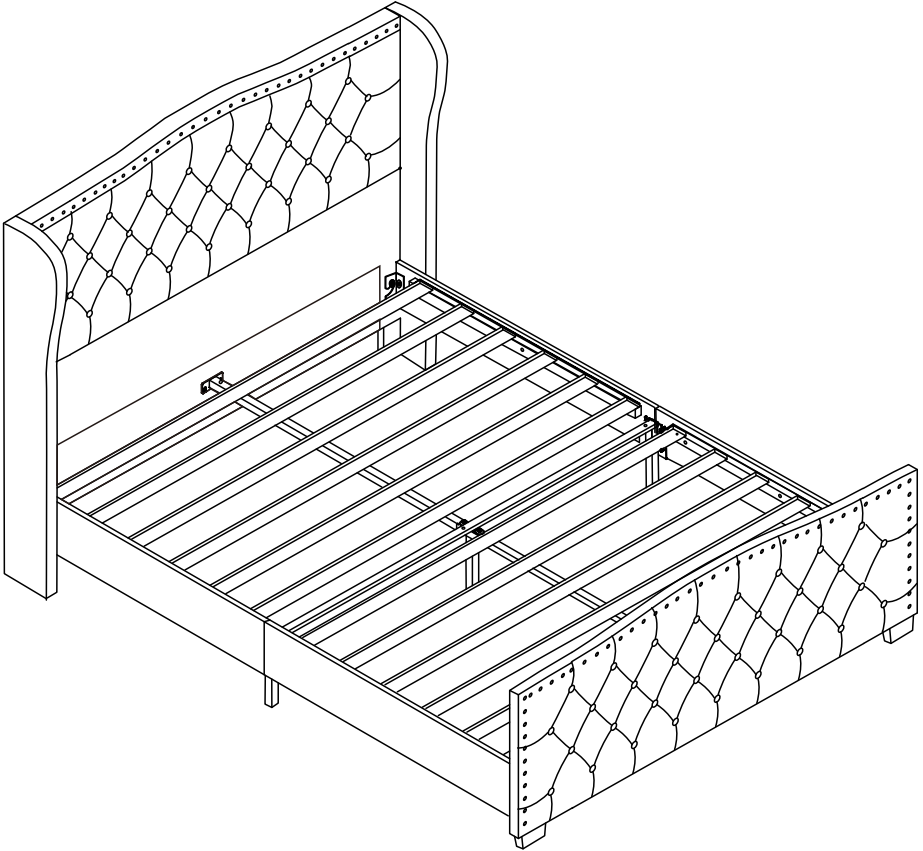

Please check that you have all the parts listed before you start assembling, if you do find that something is missing, do not continue assembly, please contact us immediately.

NOTE: Please do not completely tighten all the hardware until the entire assembly is complete!

! IMPORTANT

Please follow the instruction manuals and use a pad to protect the product during your assembly.

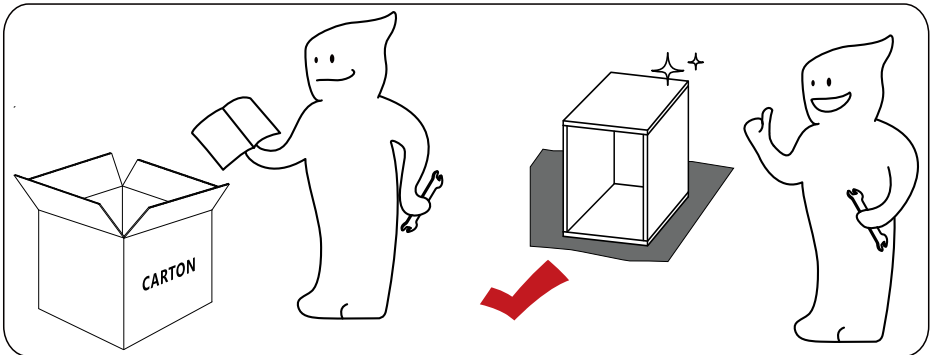
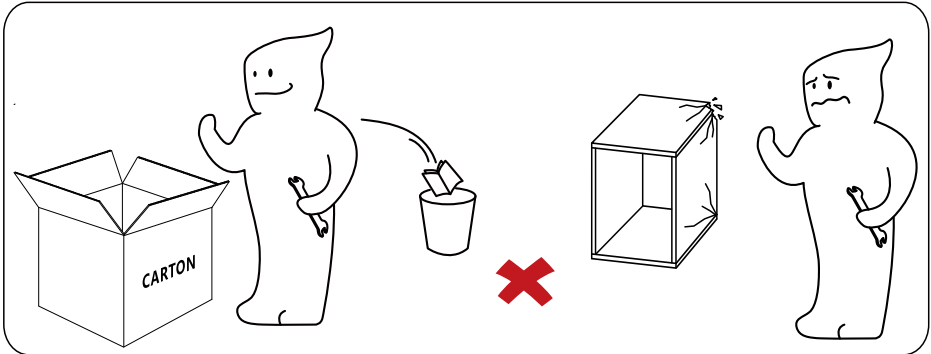

Note:





1. Should be assembled on flat ground to keep balance.
2. Before completing the installation, do not tighten the screws.

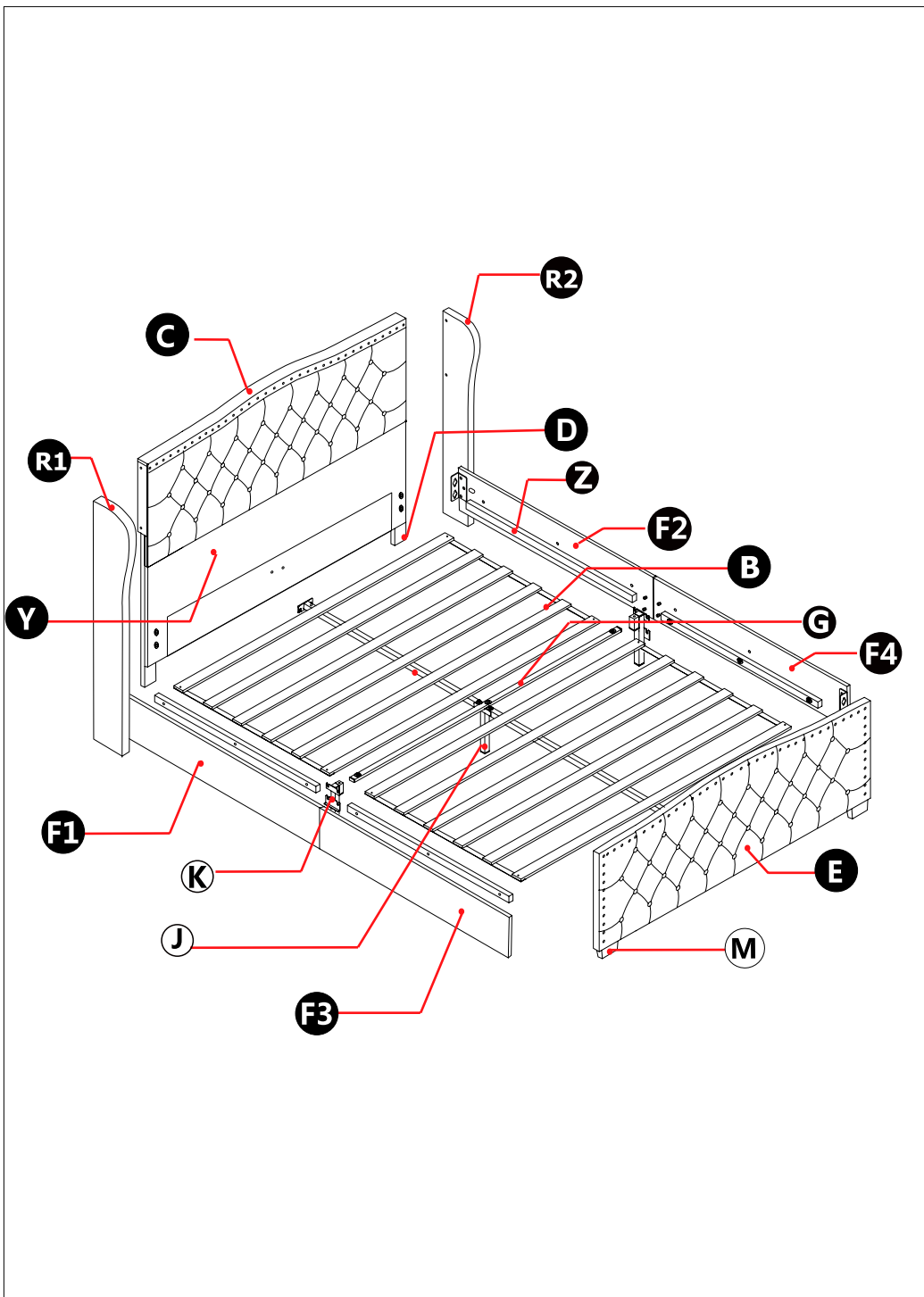

For easier and better assembly, **2** or more adults are required.

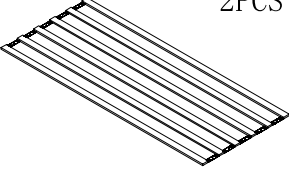
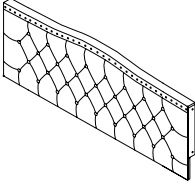

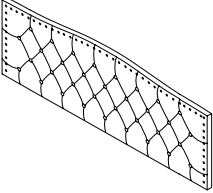
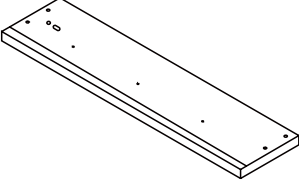
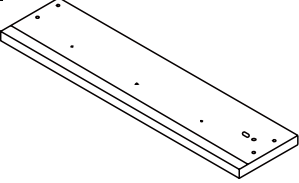
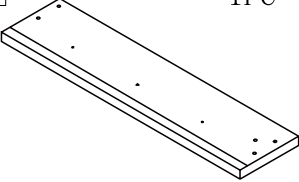
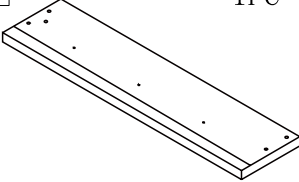
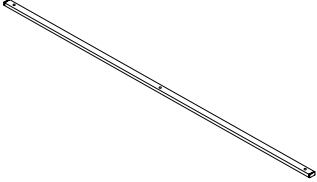
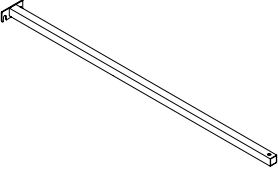
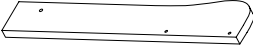
BED FRAME PARTS LIST

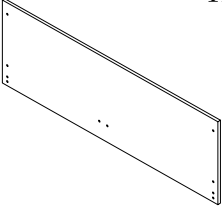
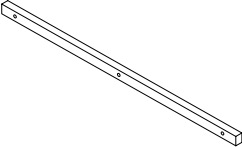
<p>B 2PCS</p>  <p>Slat</p>	<p>C 1PC</p>  <p>Top headboard</p>	<p>D 2PCS</p> 
<p>E 1PC</p>  <p>Footboard</p>	<p>F1 1PC</p>  <p>Left side rail</p>	<p>F2 1PC</p>  <p>Right side rail</p>
<p>F3 1PC</p>  <p>Left side rail</p>	<p>F4 1PC</p>  <p>Right side rail</p>	<p>G 1PC</p>  <p>Cross bar</p>
<p>H 2PCS</p>  <p>Middle support bar</p>	<p>R1 1PC</p>  <p>Left wing</p>	<p>R2 1PC</p>  <p>Right wing</p>
<p>Y 1PC</p>  <p>Bottom headboard</p>	<p>Z 4PCS</p>  <p>side bar</p>	

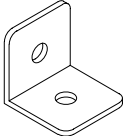
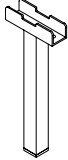
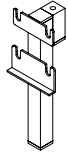
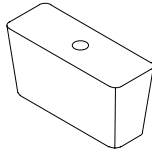
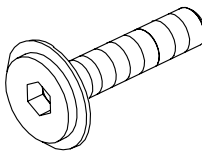
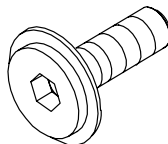
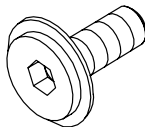
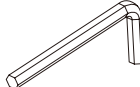
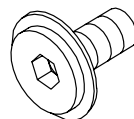
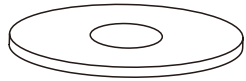
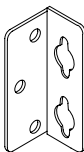
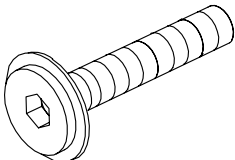

FITTING PART LIST

<p>I 1PCS</p>  <p>Connector</p>	<p>J 1PCS</p>  <p>Support leg</p>	<p>K 2PCS</p>  <p>side leg</p>
<p>M 2PCS</p>  <p>Leg</p>	<p>L 14PCS</p>  <p>M8*45</p>	<p>N 17PCS</p>  <p>M8*35</p>
<p>O 8PCS</p>  <p>M8*25</p>	<p>P 1PC</p>  <p>M6</p>	<p>S 26PCS</p>  <p>M8*18</p>
<p>T 2PCS</p>  <p>M8*22*1.5</p>	<p>X 4PCS</p> 	<p>U 2PCS</p>  <p>M8*55</p>

step1

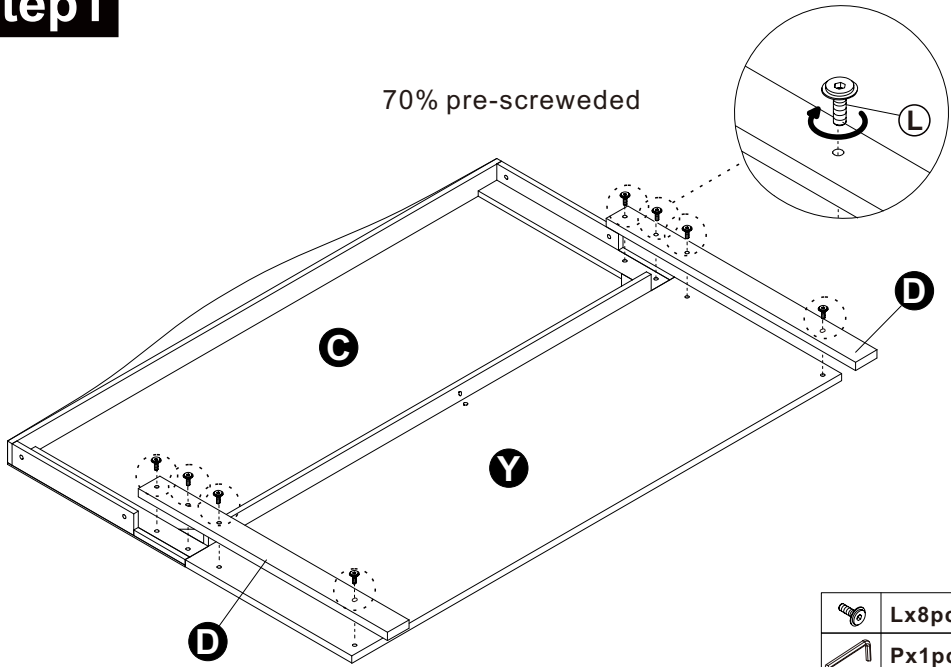

70% pre-screwed

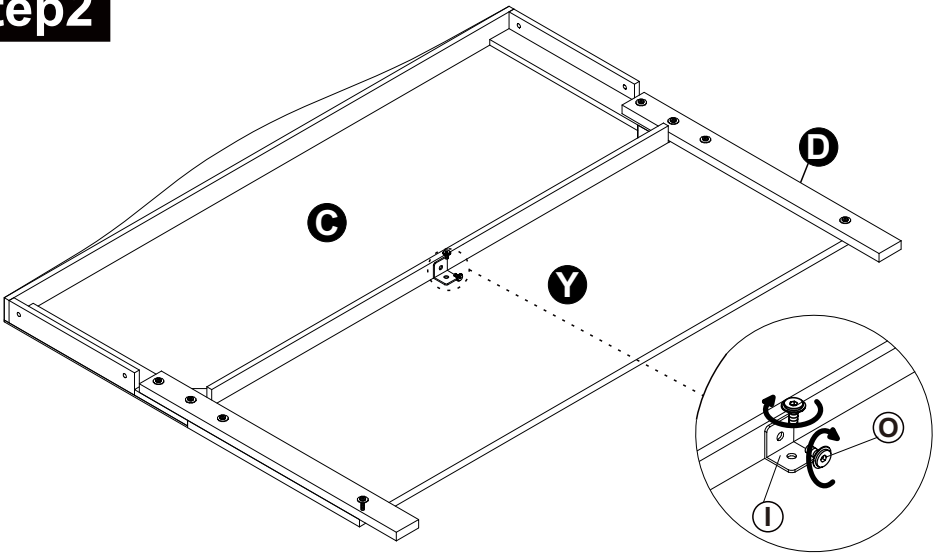

	Lx8pcs
	Px1pc

step2



	Ix1pcs
	Ox2pcs
	Px1pc

ASSEMBLY INSTRUCTIONS

step3

During the assembly, please first half-tighten all the screws into the holes. After all the screws are set, fully tighten them.

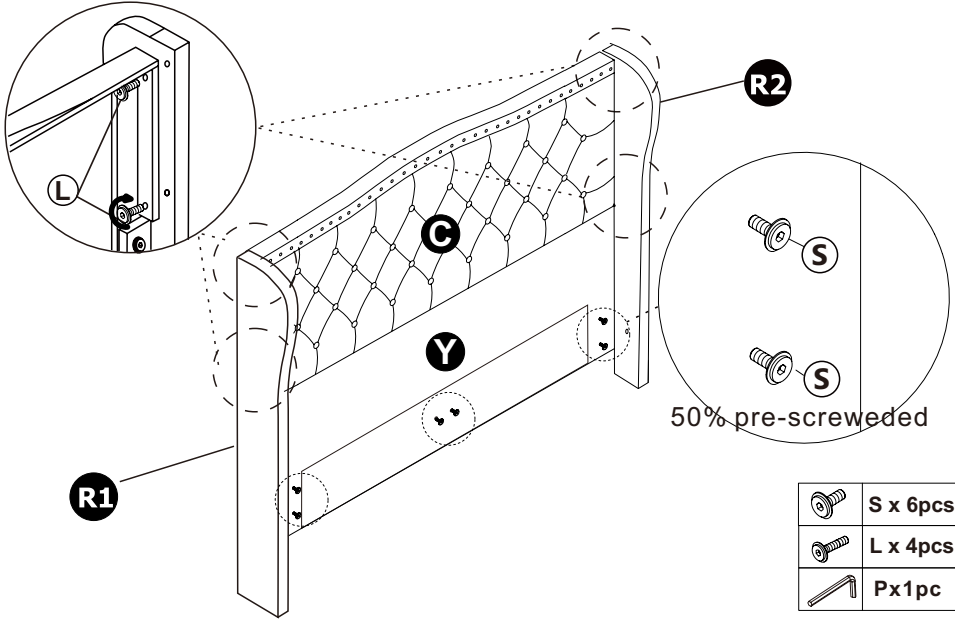

step4

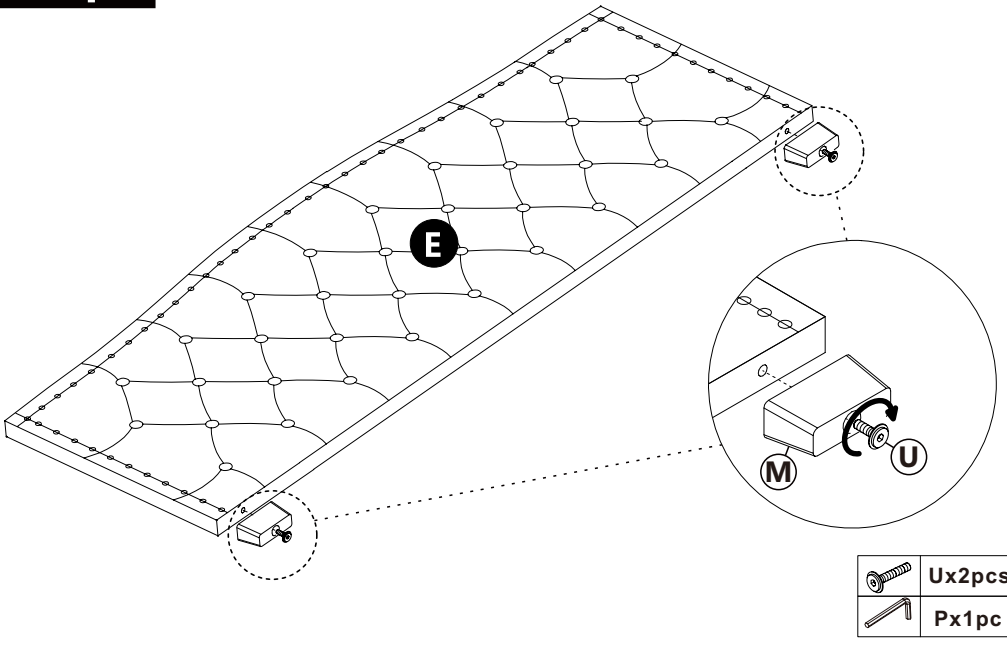

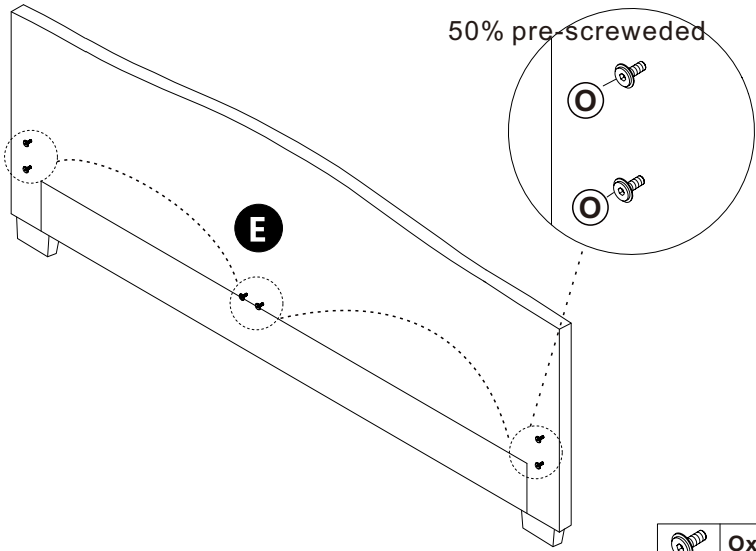

step5

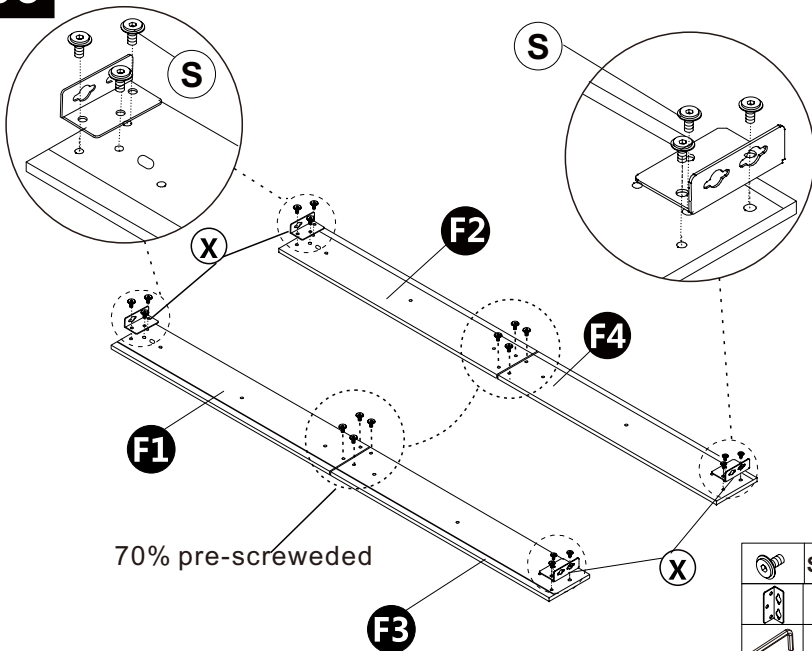

	Ox6pcs
	Px1pc

step6



	Sx20pcs
	Xx4pcs
	Px1pc

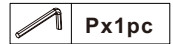
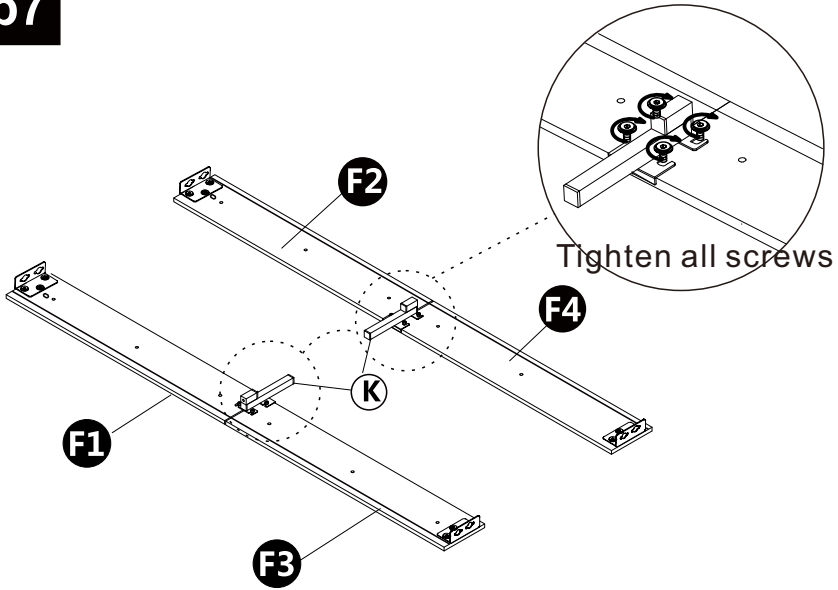

step 7

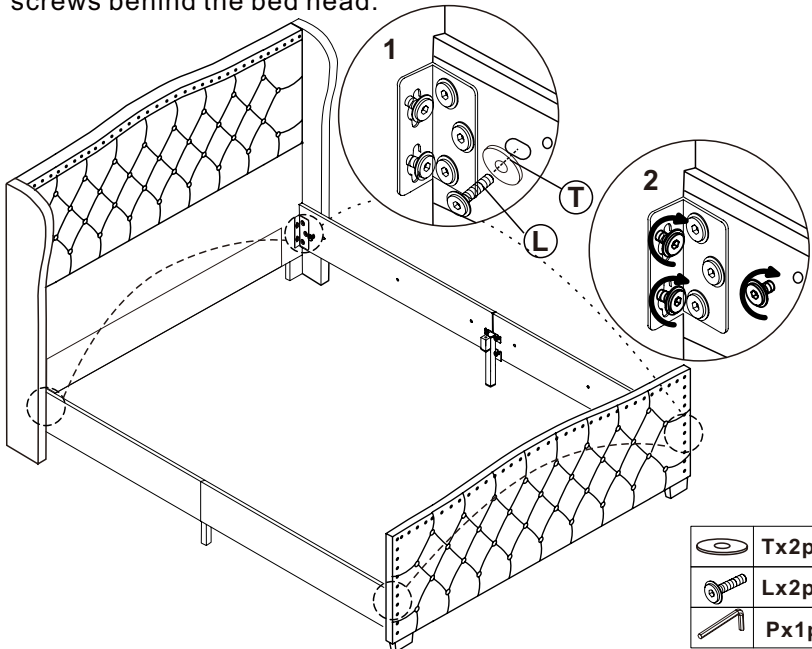

step 8

Align the holes and tighten the marked screws, then tighten the screws behind the bed head.



	Tx2pcs
	Lx2pcs
	Px1pc

step9

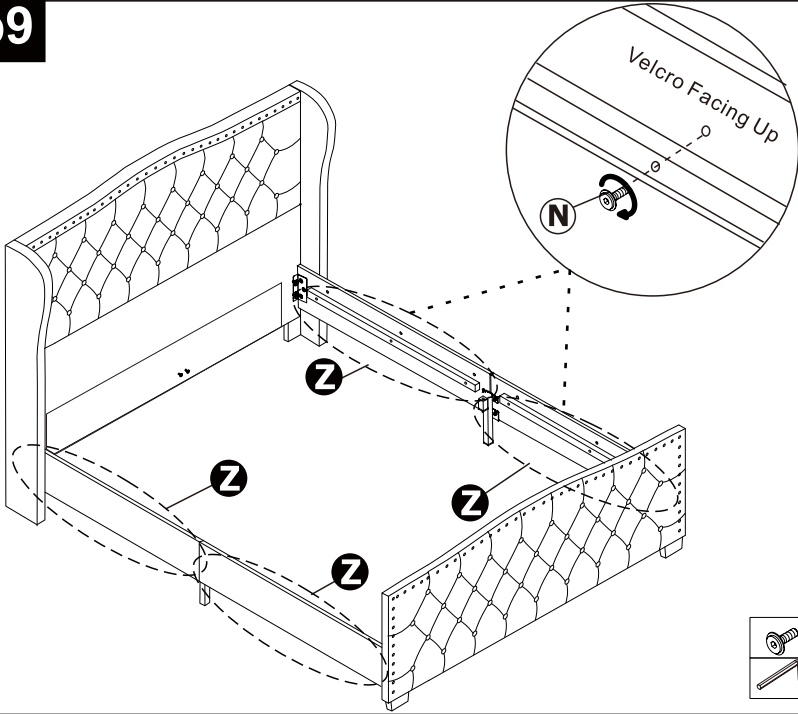

step10

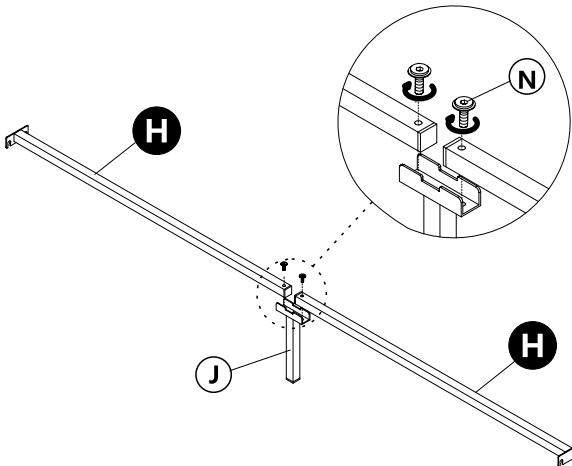

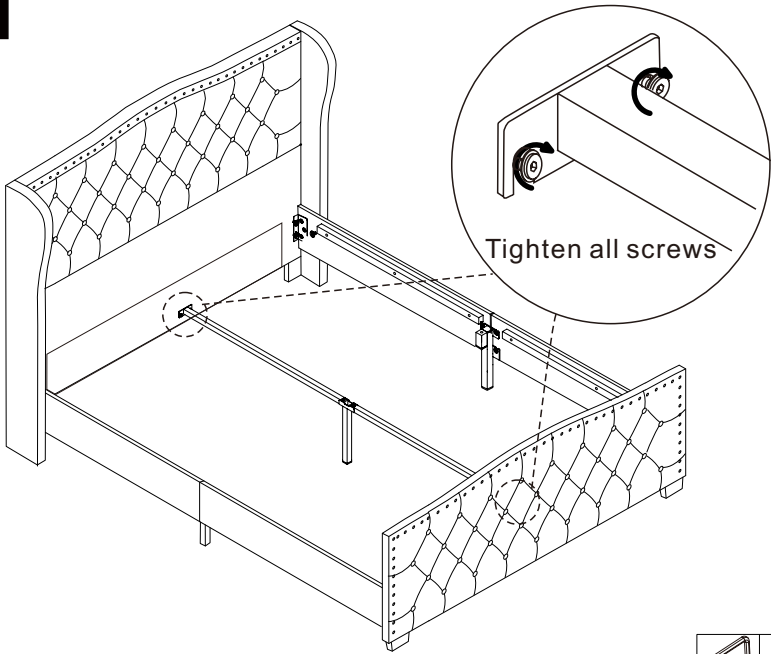

step11

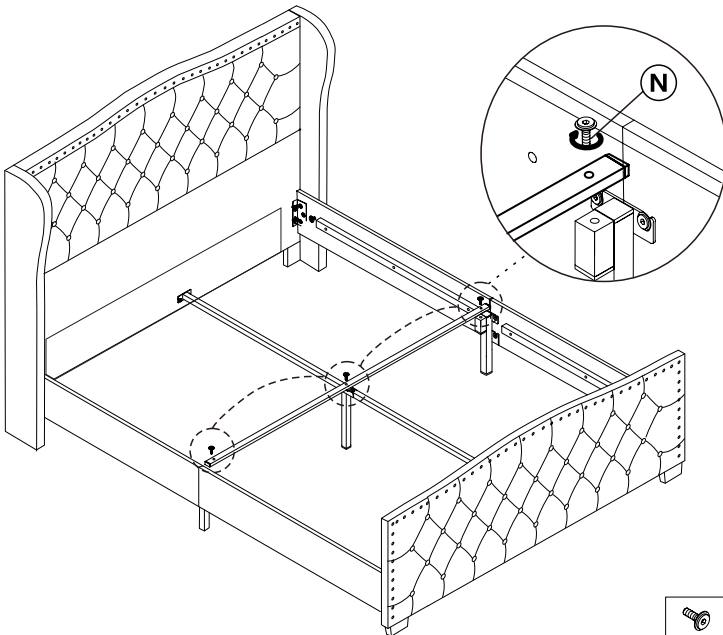

 Px1pc

step12



 Nx3pcs
 Px1pc

step13

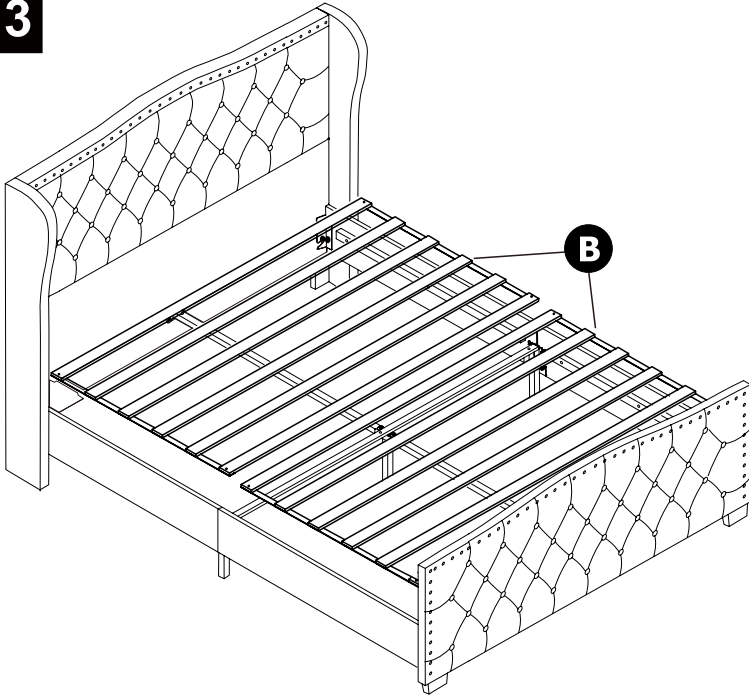

step14

