

Extendable Kitchen Island

Assembly Instructions - Please keep for future reference

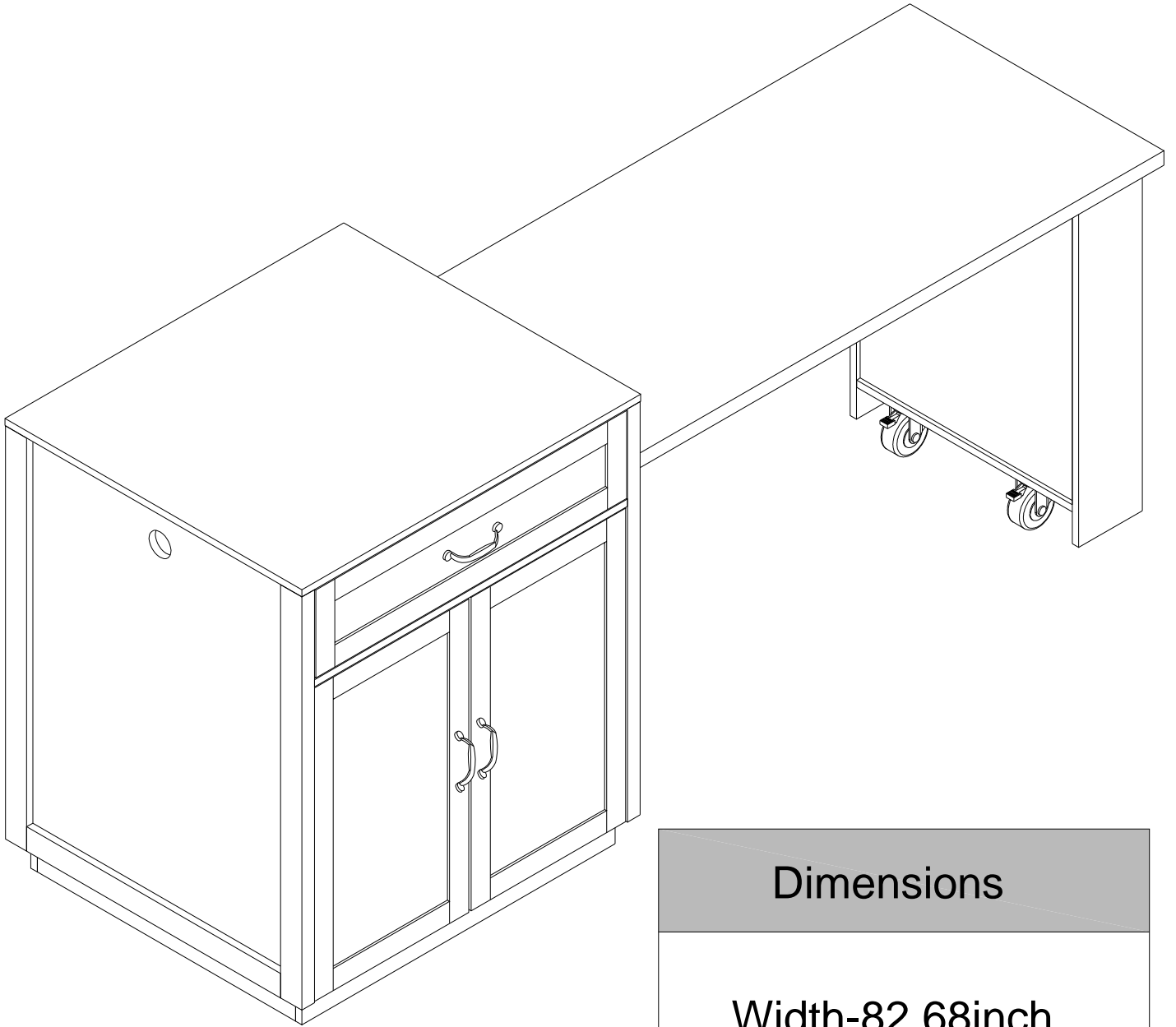

Dimensions

Width-82.68inch

Depth-27.56inch

Height-36.22inch

Important - please read these instructions fully before starting assembly



Safety and Care Advice

Important – Please read these instructions fully before starting assembly

- Check you have all the components and tools listed on the following pages.
- Remove all fittings from the plastic bags and separate them into their groups.
- Keep children and animals away from the work area, small parts could choke if swallowed.
- Make sure you have enough space to layout the parts before starting.

- During assembly do not stand or put weight on the product, this could cause damage.
- Assemble the item as close to its final position (in the same room) as possible.
- Assemble on a soft level surface to avoid damaging the unit or your floor.
- Parts of the assembly will be easier with 2 people.



power drill is set on a low torque setting.

- To reduce the likelihood of damaging your product please ensure that your

Care and maintenance

- Only clean using a damp cloth and mild detergent, do not use bleach or abrasive cleaners.
- From time to time check that there are no loose screws on this unit.
- This product should not be discarded with household waste. Take to your local authority waste disposal centre.

Handy Hints

- Assemble all parts and bolts loosely during assembly, only once the product is complete should you fully tighten the bolts
- Regularly check and ensure that all bolts and fittings are tightened properly.

WARNING
In order to help prevent overturning – please follow these instructions

To help prevent product toppling over please follow the below steps:-

- Use the anti tip stap or wall fixing method provided (if applicable)
- Do not allow children to climb or hang on the furniture
- Do not open more than one drawer at a time
- Do not place heavy items in the top drawers
- Do not place heavy items on top of the furniture, unless the furniture has been designed for this purpose

Using Camlocks

Step 1

Connect the male camlock as directed in the assembly instructions using a screwdriver.

1

DO NOT OVER TIGHTEN.
NE PAS SERRER EXCESSIVEMENT.

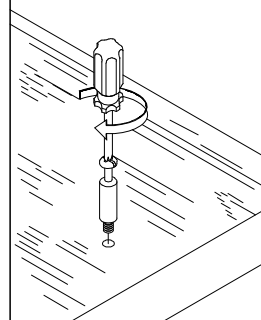

Step 2

Push the male camlock into the entry hole.

2

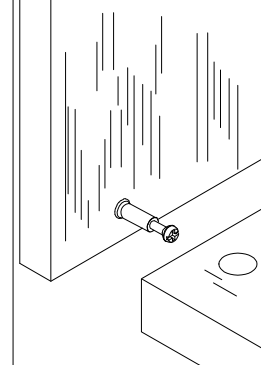

Step 3

Insert the female camlock as shown in the instruction.

Note: ensure that the arrow on the top of the camlock points towards the entry hole for the male camlock.

3

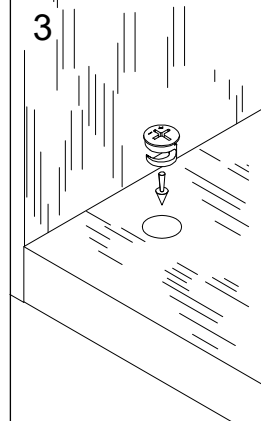

Step 4

Turn the female camlock clockwise with a screwdriver.

You should feel a click when the camlock is locked in place.

The joint is now secure.

4

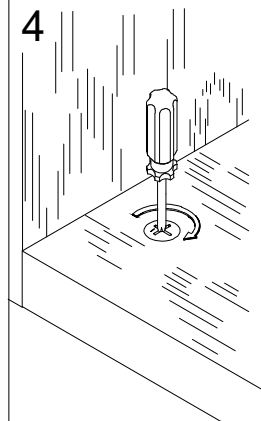



BST A RELIABLE TESTING FOR TRUST
GLOBAL TESTING AND CERTIFICATION PRECISION SERVICE CLOUD FACTORY

Supplier's Declaration of Conformity

This device complies with part 15 of the FCC Rules. Operation is subject to the condition that this device does not cause harmful interference

Certification Summary

Applicant:	Zhangzhou Jinhe Electronic Technology Co., Ltd
Address:	Jiao Mei Zhen Hong Jian Cun Jiao Song, Taiwan Merchants Investment Zone, Zhangzhou, Fujian Province 3rd Floor, Building C, No. 59 Road
Manufacturer:	Zhangzhou Jinhe Electronic Technology Co., Ltd
Address:	Jiao Mei Zhen Hong Jian Cun Jiao Song, Taiwan Merchants Investment Zone, Zhangzhou, Fujian Province 3rd Floor, Building C, No. 59 Road
Test standard:	FCC Part 15 Class B
Product Type:	JH-13
Trade Name:	/
Main Test Model:	JH-13, JH-22, JH-23, JH-24, JH-25, JH-26, JH-27, JH-28, JH-29, JH-30
Certificate Number:	XD202351120830001CR-A
Report number:	XD202351120830001CR
Issuance Date:	Dec.08, 2023
Tested by:	Dongguan BST Testing Co., Ltd.

We, the responsible party:
Zhangzhou Jinhe Electronic Technology Co., Ltd
declare that the product
JH-13



was tested to conform to the applicable FCC Rules and regulations. The method of testing was in accordance to the most accurate measurement standards possible, and that all necessary steps have been enforced to assure that all production units of the same equipment will continue to comply with the Federal Communications Commission's requirements.



Signature of Officer

2023-12-08

Date

Dongguan BST Testing Co., Ltd.

Add: Chaomei Industrial Park, Donghai Road, Yongan Community Yantian Street Yantian District, Shenzhen, Guangdong, China
Certificate Search: <http://www.bst-lac.com>, Tel: 0769-85990045, E-mail: christian_bst@yeah.net

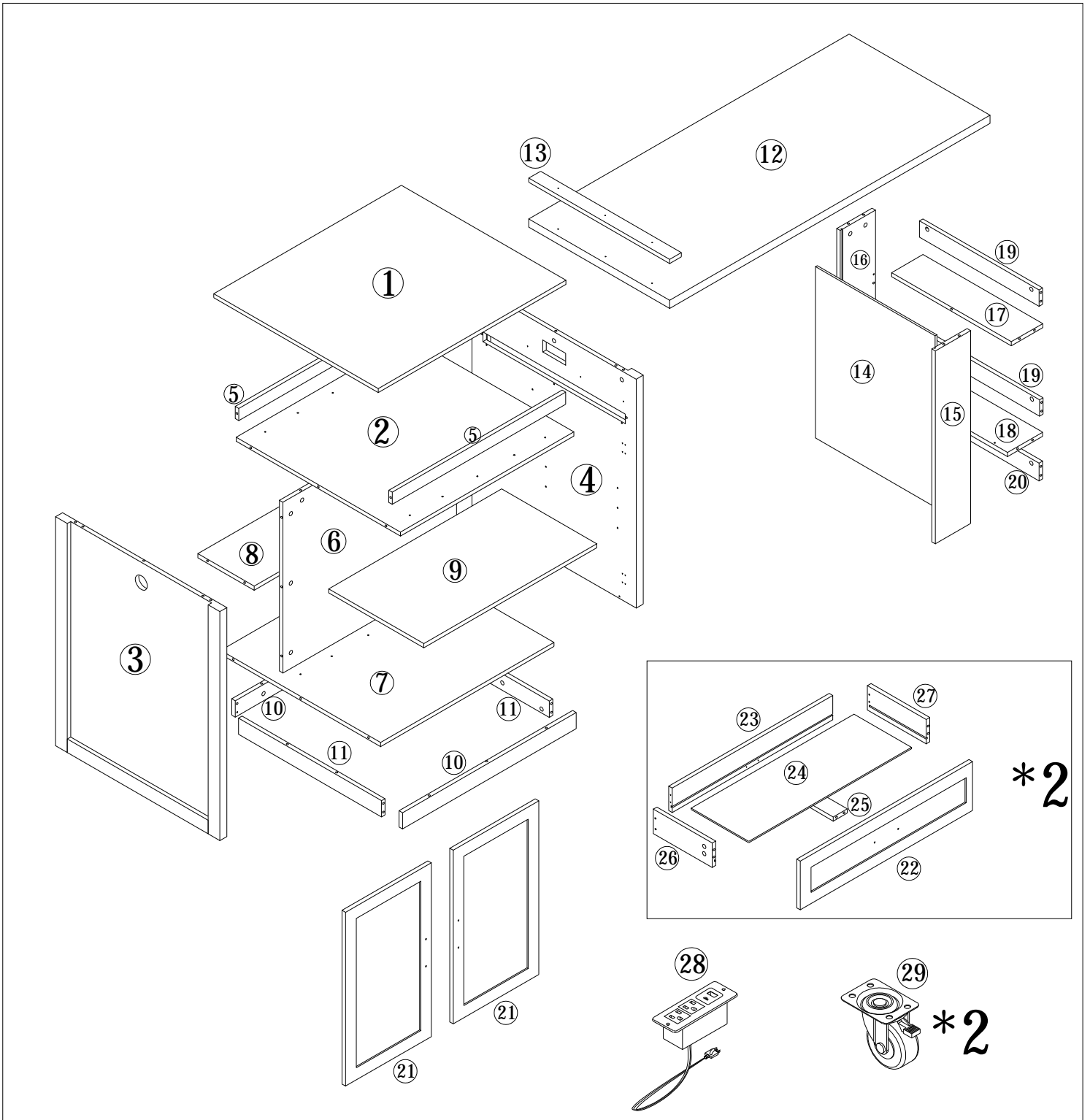

BOX1

11x2

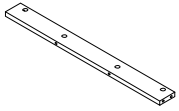

616x60x12mm

12x1

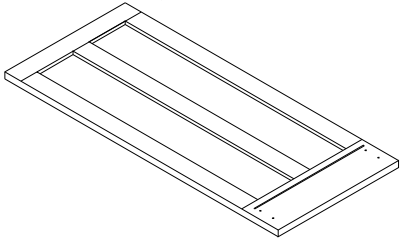

1365x600x27mm

14x1

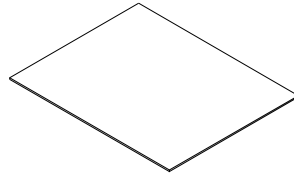

640x518x5mm

17x1

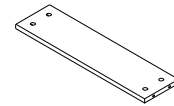

510x135.5x12mm

18x1

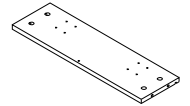

510x149.5x15mm

19x2

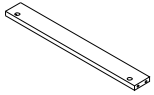

510x60x12mm

20x1

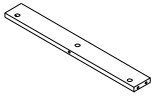

510x65x12mm

21x2

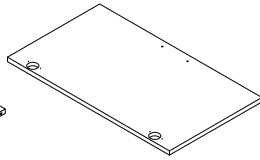

644x368x15mm

23x2

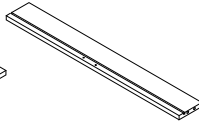

696x90x12mm

24x2

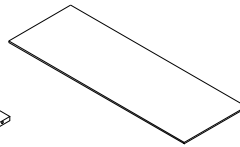

700x246x3mm

25x2

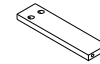

238x60x12mm

26x2

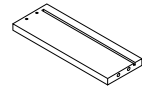

250x90x12mm

27x2

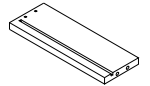

250x90x12mm

BOX2

1x1

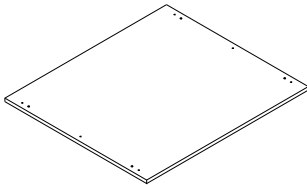

800x700x15mm

2x1

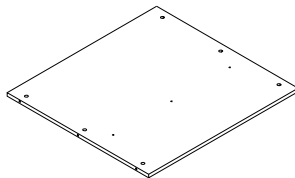

745x700x12mm

3x1

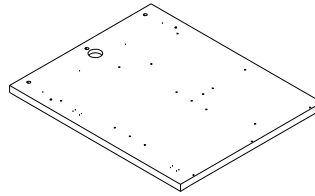

845x700x27mm

4x1

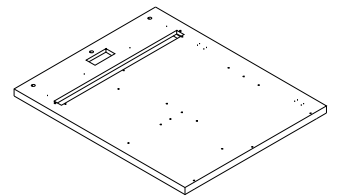

845x700x27mm

5x2

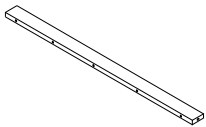

745x45x12mm

6x1

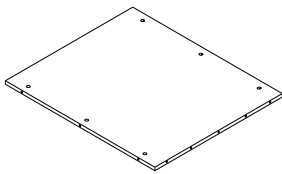

745x633x12mm

7x1

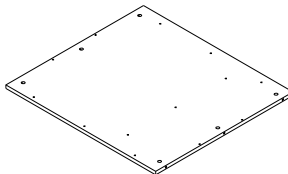

745x683x15mm

8x1

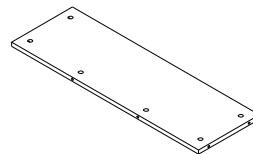

745x240x12mm

9x1

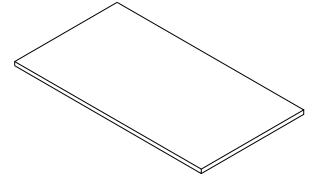

743x411x12mm

10x2

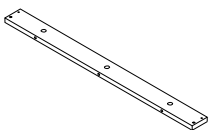

740x60x12mm

13x1

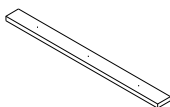

600x50x12mm

15x1

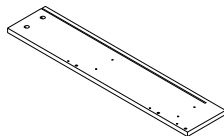

712x150x15mm

16x1

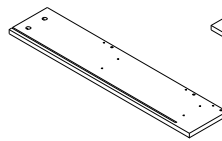

712x150x15mm

22x2

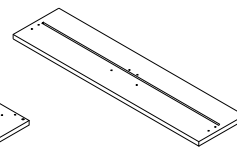





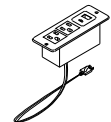

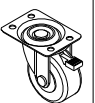

740x180x17mm

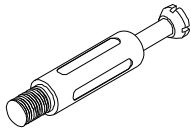
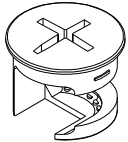
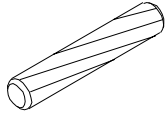
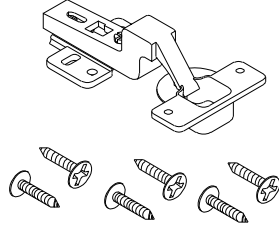
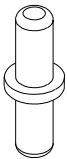
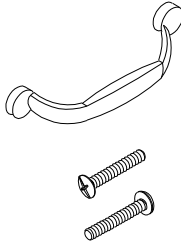
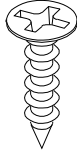
28x1

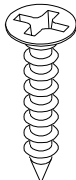

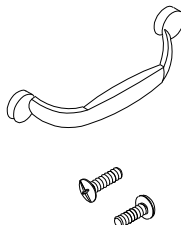
29x2

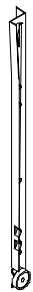

<p style="text-align: center;">A</p>  <p style="text-align: center;">75PCS</p>	<p style="text-align: center;">B</p>  <p style="text-align: center;">75PCS</p>	<p style="text-align: center;">C</p> <p style="text-align: center;">$\phi 8*30\text{mm}$</p>  <p style="text-align: center;">26PCS</p>	<p style="text-align: center;">D</p>  <p style="text-align: center;">4PCS</p>
<p style="text-align: center;">E</p>  <p style="text-align: center;">4PCS</p>	<p style="text-align: center;">F</p>  <p style="text-align: center;">2PCS</p>	<p style="text-align: center;">G</p> <p style="text-align: center;">MB. 5*14mm</p>  <p style="text-align: center;">18PCS</p>	<p style="text-align: center;">H</p> <p style="text-align: center;">MB*14mm</p>  <p style="text-align: center;">8PCS</p>
<p style="text-align: center;">I</p> <p style="text-align: center;">MB. 5*30mm</p>  <p style="text-align: center;">27PCS</p>	<p style="text-align: center;">J</p>  <p style="text-align: center;">6PCS</p>	<p style="text-align: center;">K</p>  <p style="text-align: center;">2PCS</p>	<p style="text-align: center;">CL</p>  <p style="text-align: center;">2PCS</p>
<p style="text-align: center;">CR</p>  <p style="text-align: center;">2PCS</p>	<p style="text-align: center;">DL</p>  <p style="text-align: center;">2PCS</p>	<p style="text-align: center;">DR</p>  <p style="text-align: center;">2PCS</p>	

"B" Hardware installation example

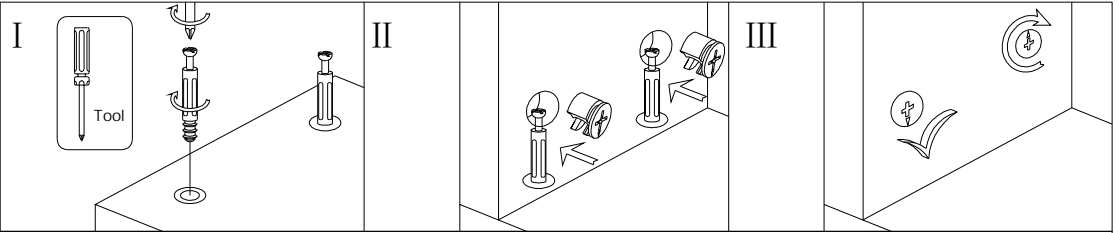

1. *2

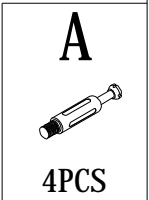
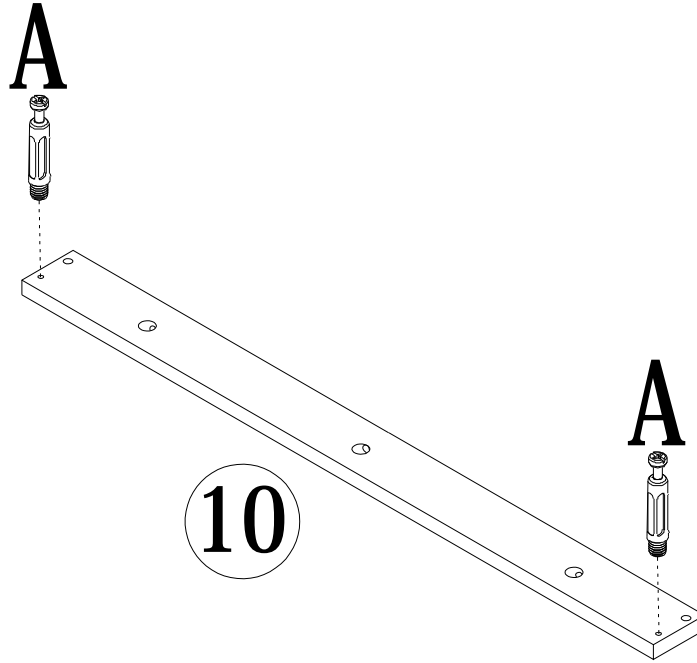

2.

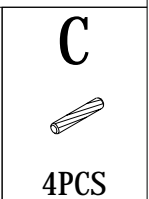
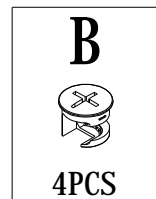
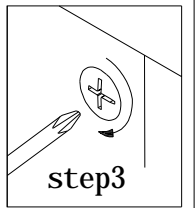
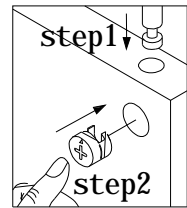
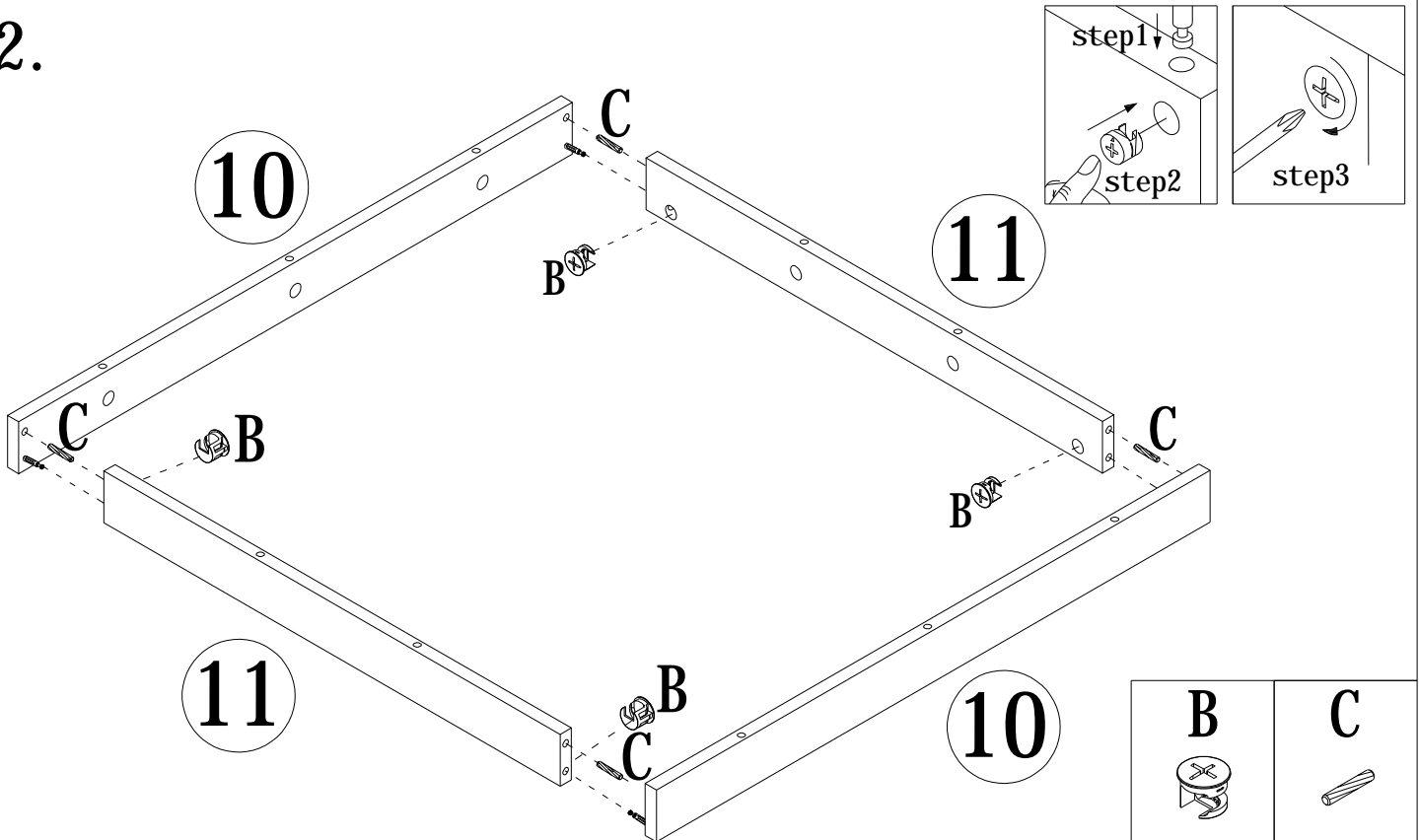

3.

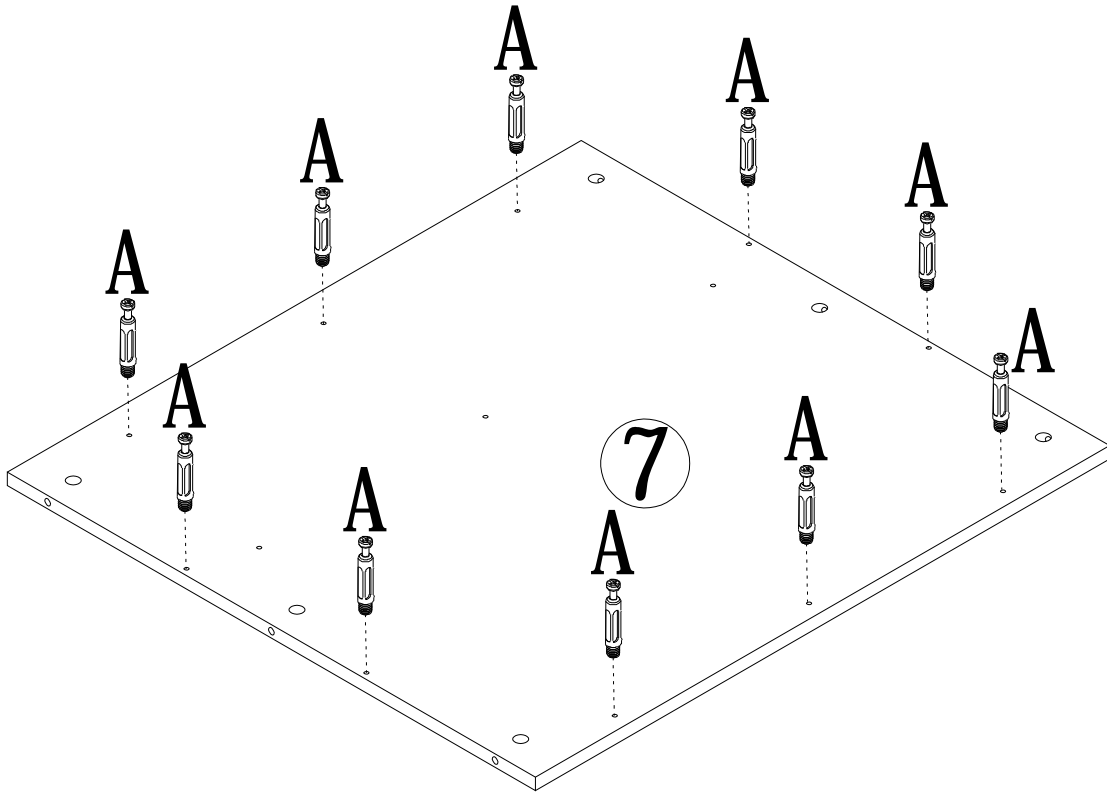

A



10PCS

4.

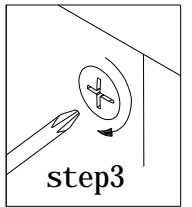
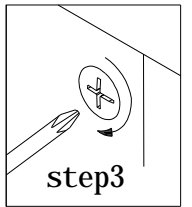
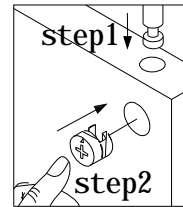
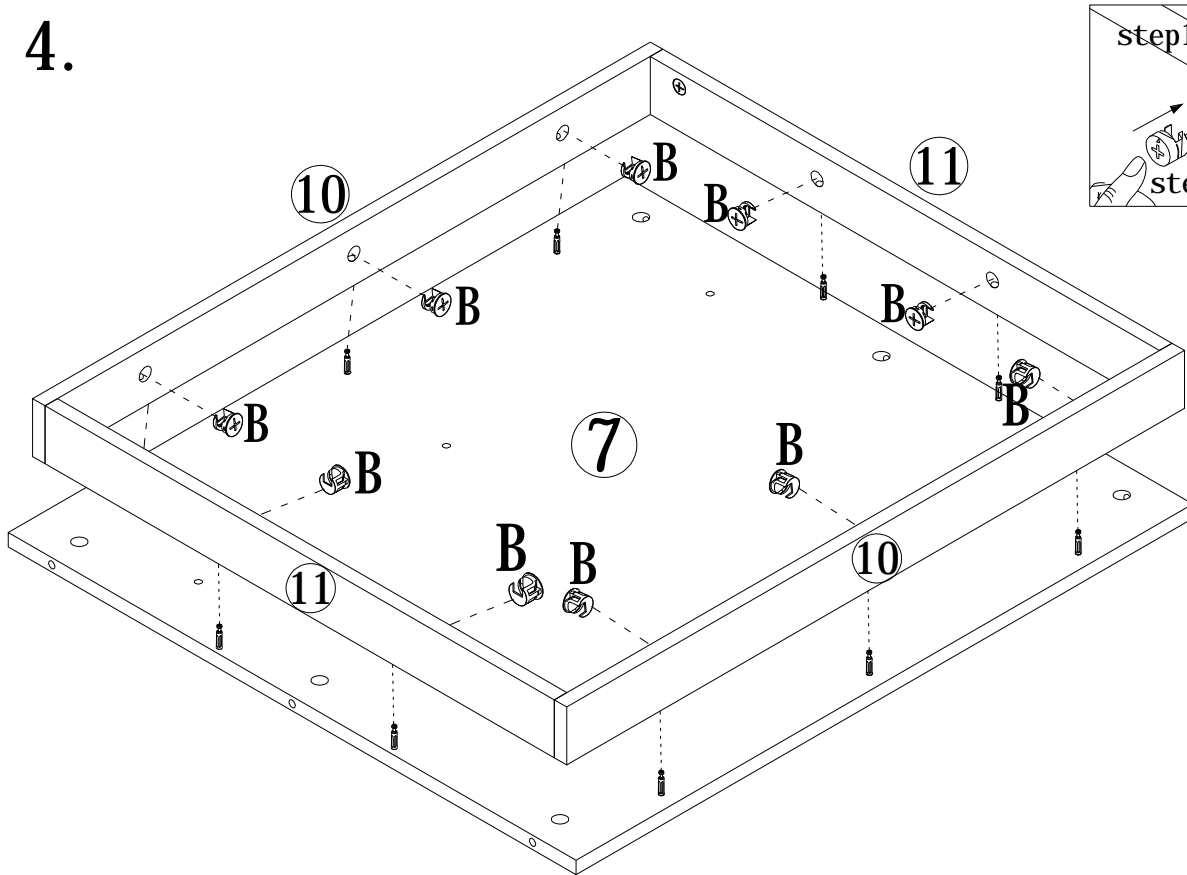

B



10PCS

5.

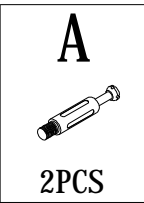
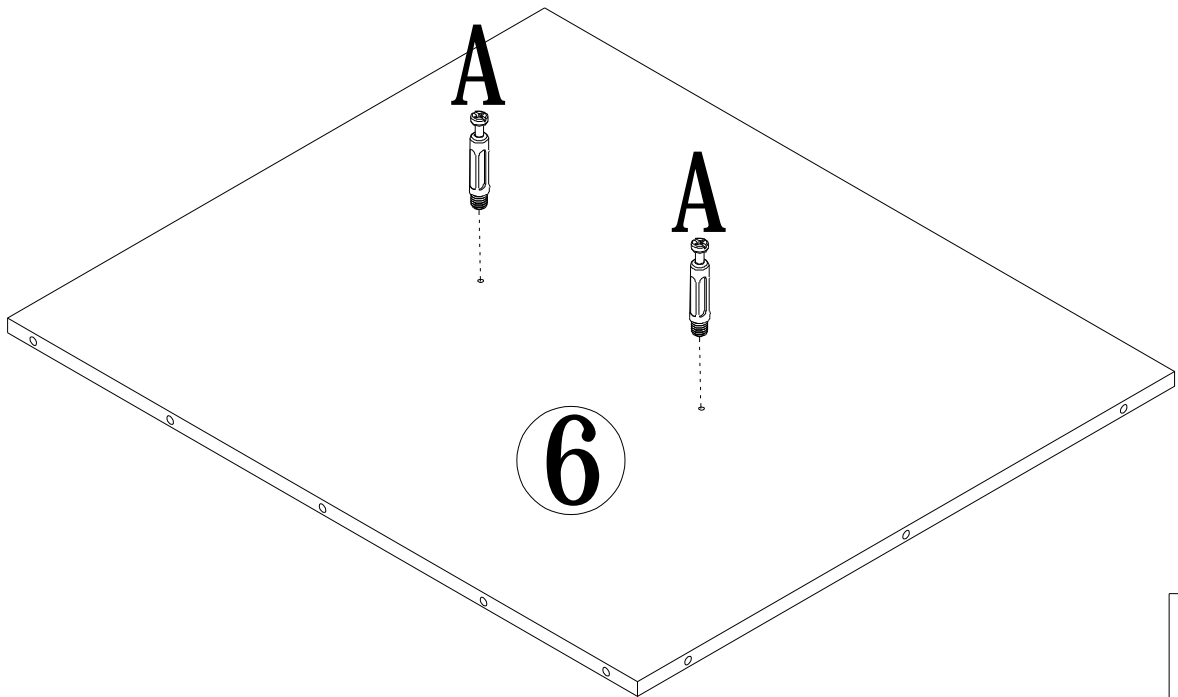

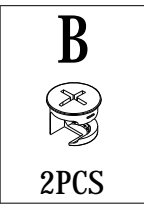
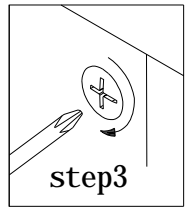
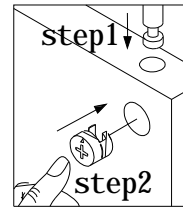
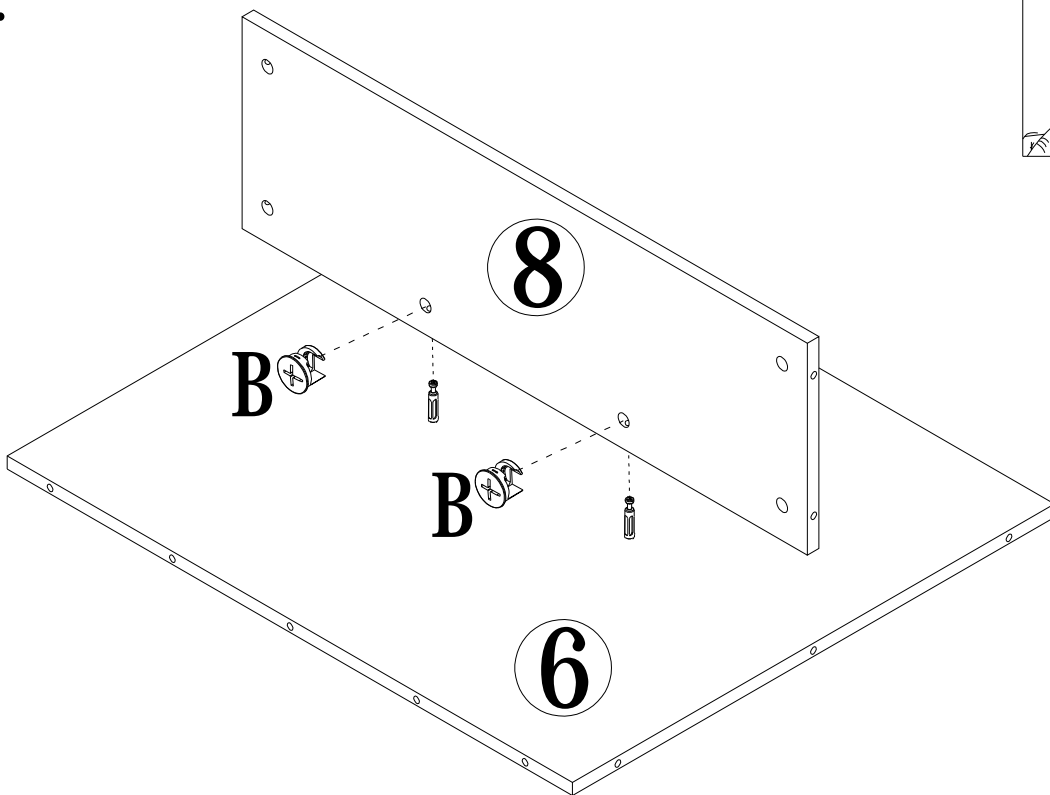

6.



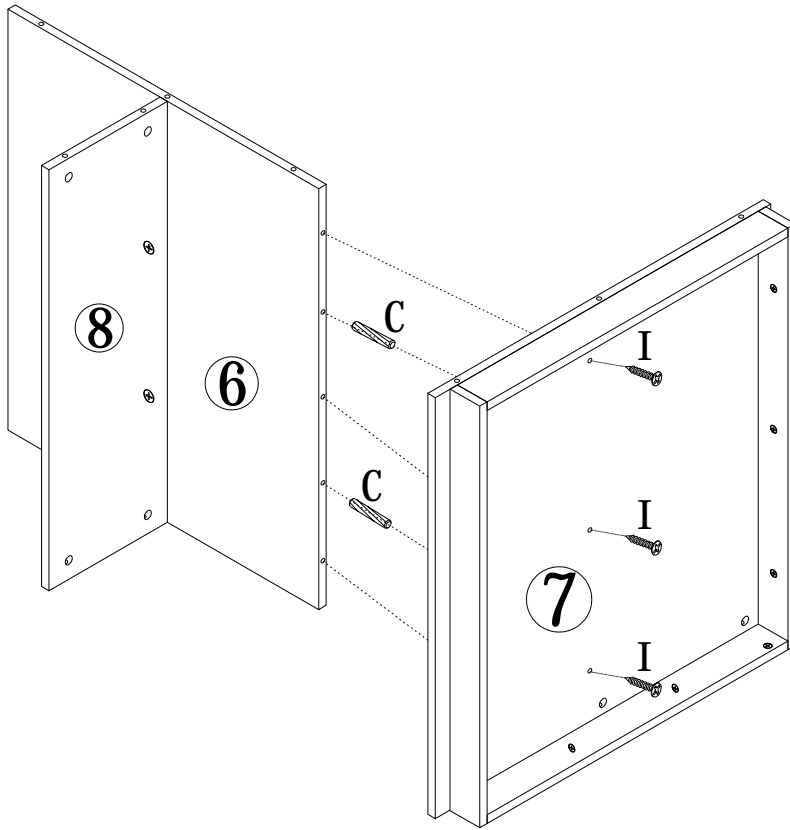

7.



C  2PCS	I  3PCS
---	--

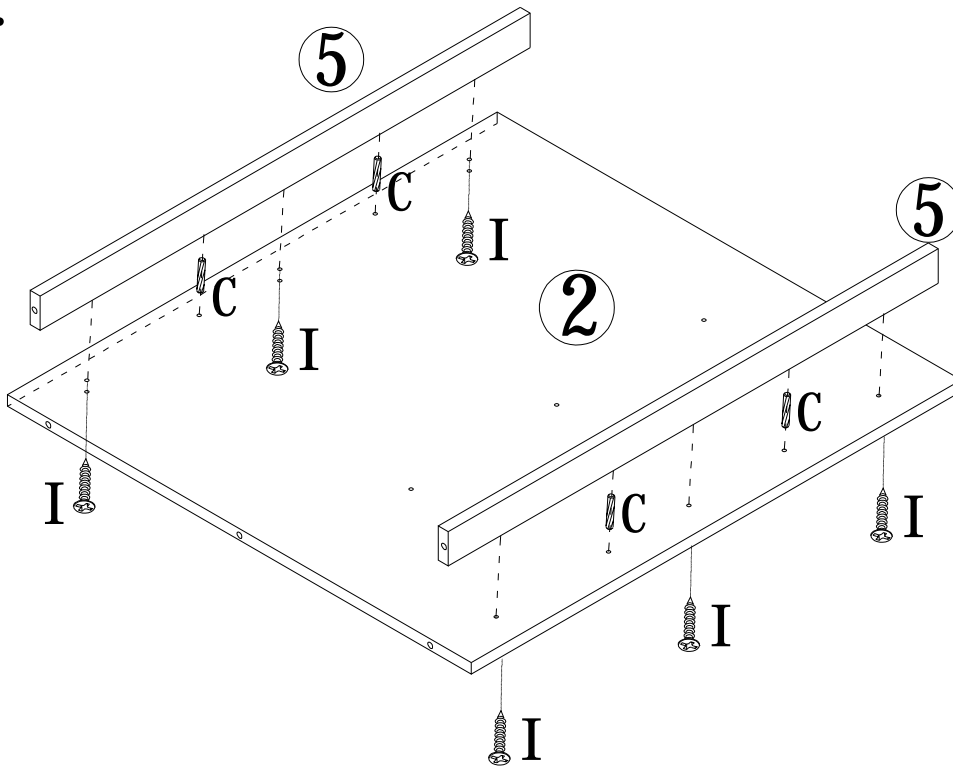

8.



C  4PCS	I  6PCS
---	---

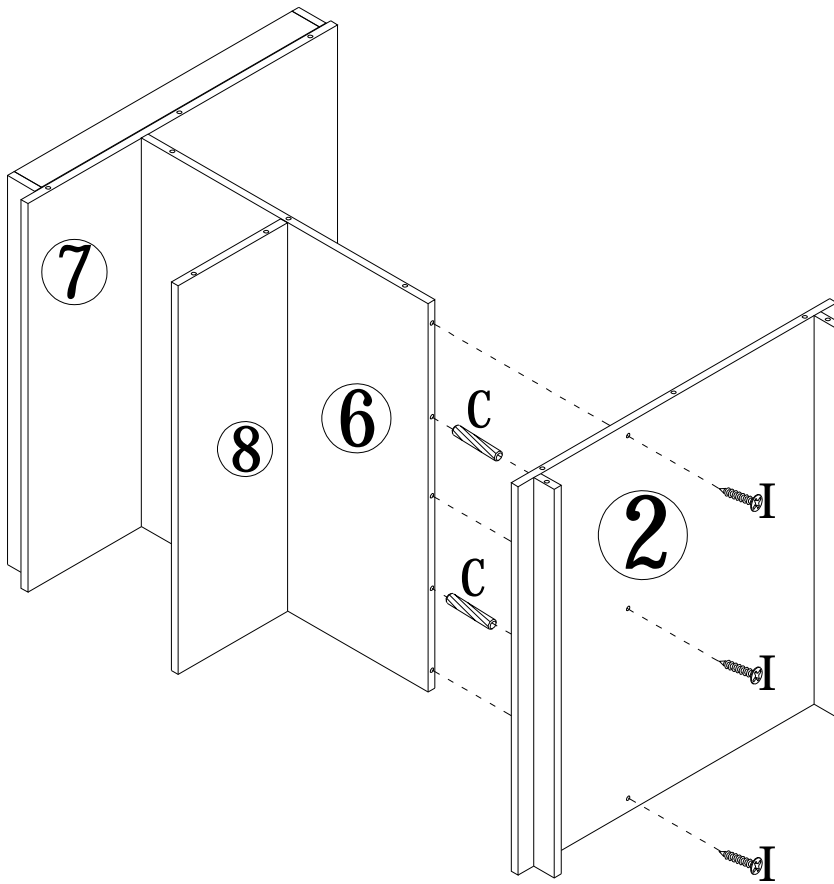

9.

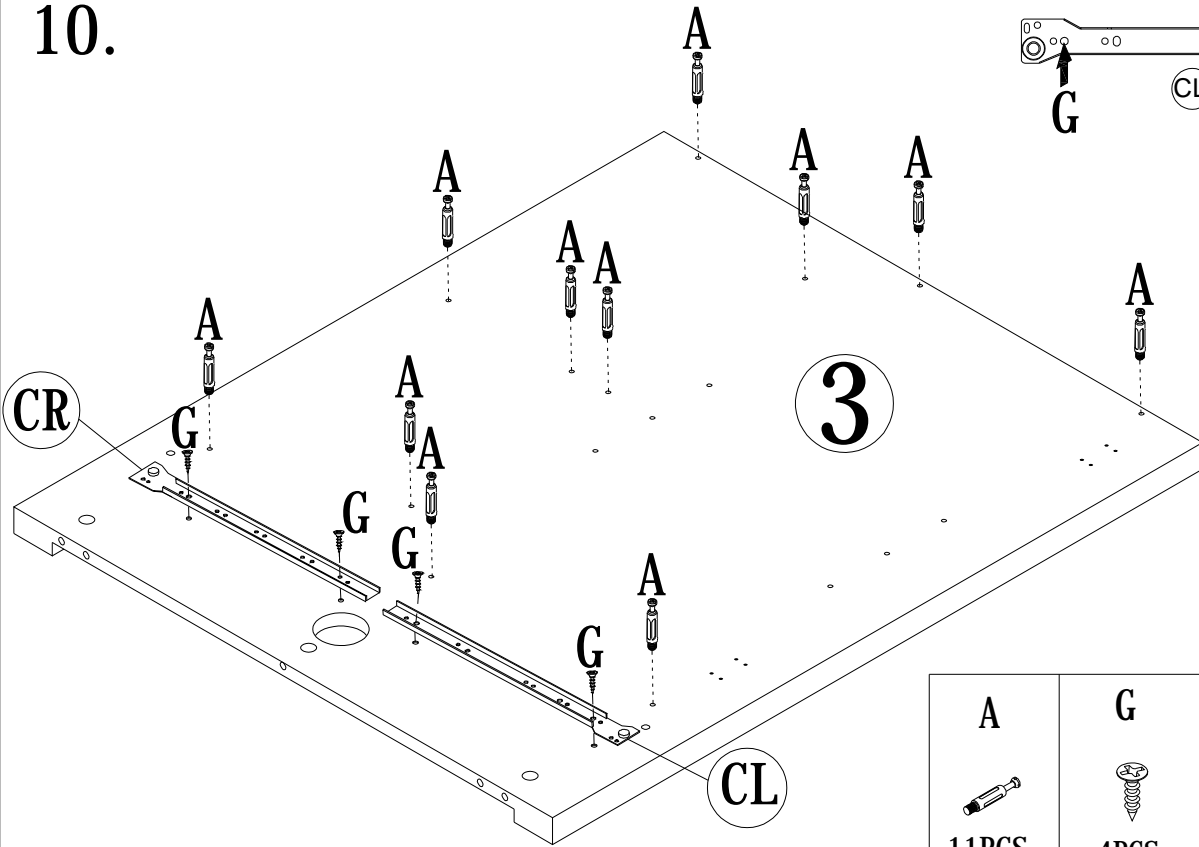

C  2PCS	I  3PCS
---	--

10.

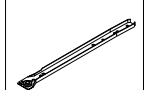
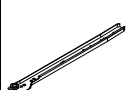

A  11PCS	G  4PCS	CL  1PC	CR  1PC
--	---	---	---

11.

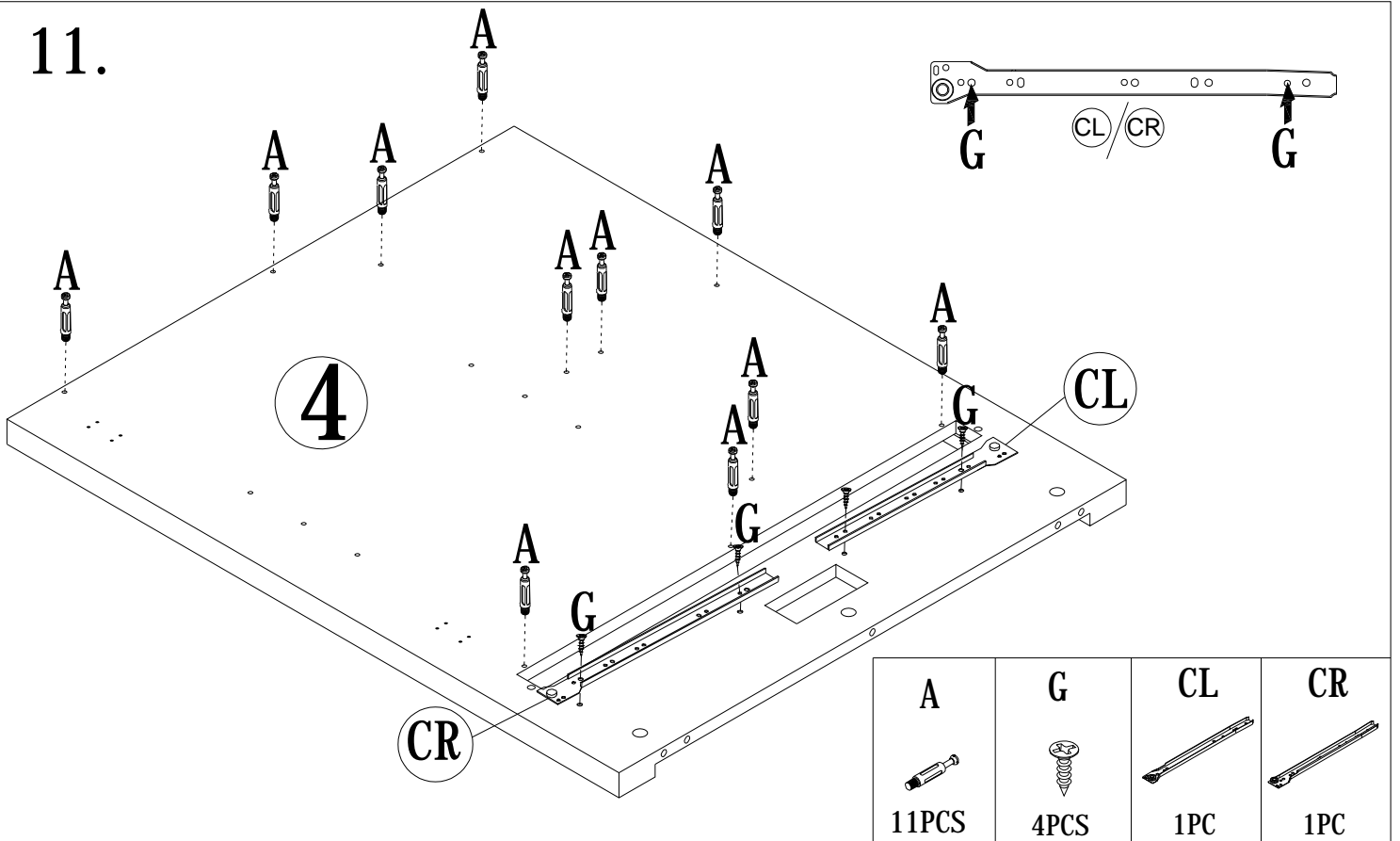

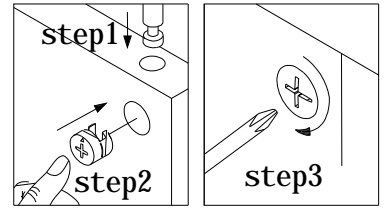
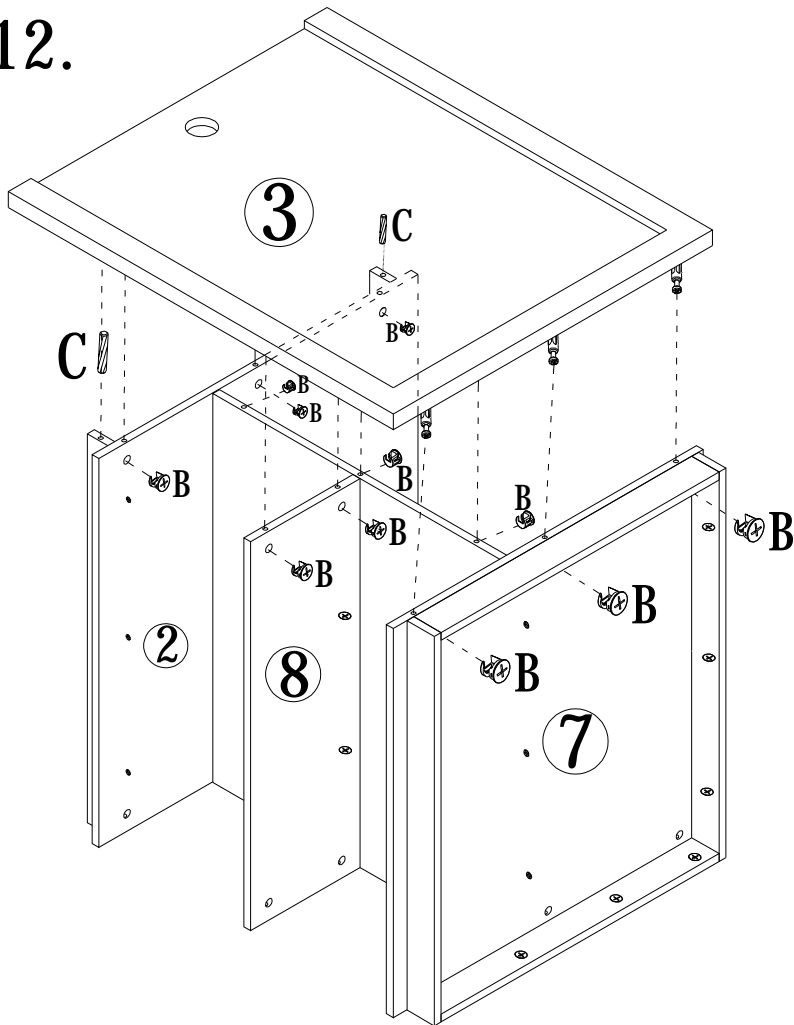

12.

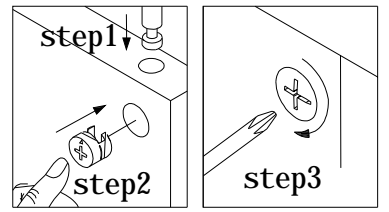
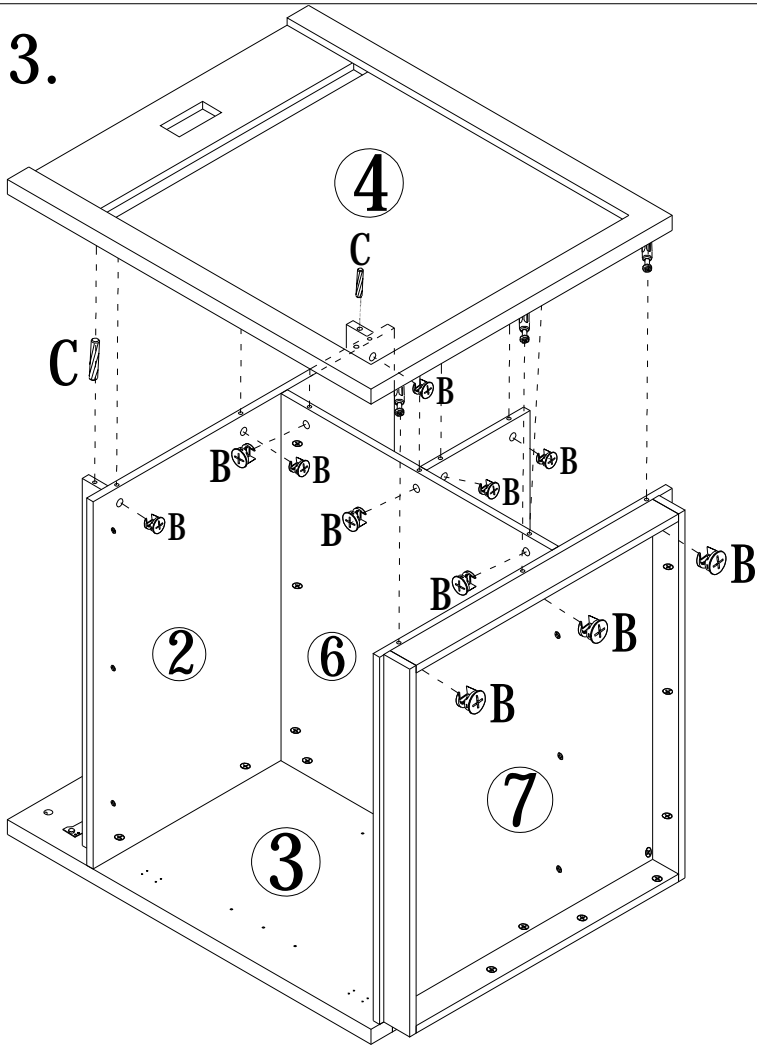

B	C
11PCS	2PCS

13.



B  11PCS	C  2PCS
--	---

14.

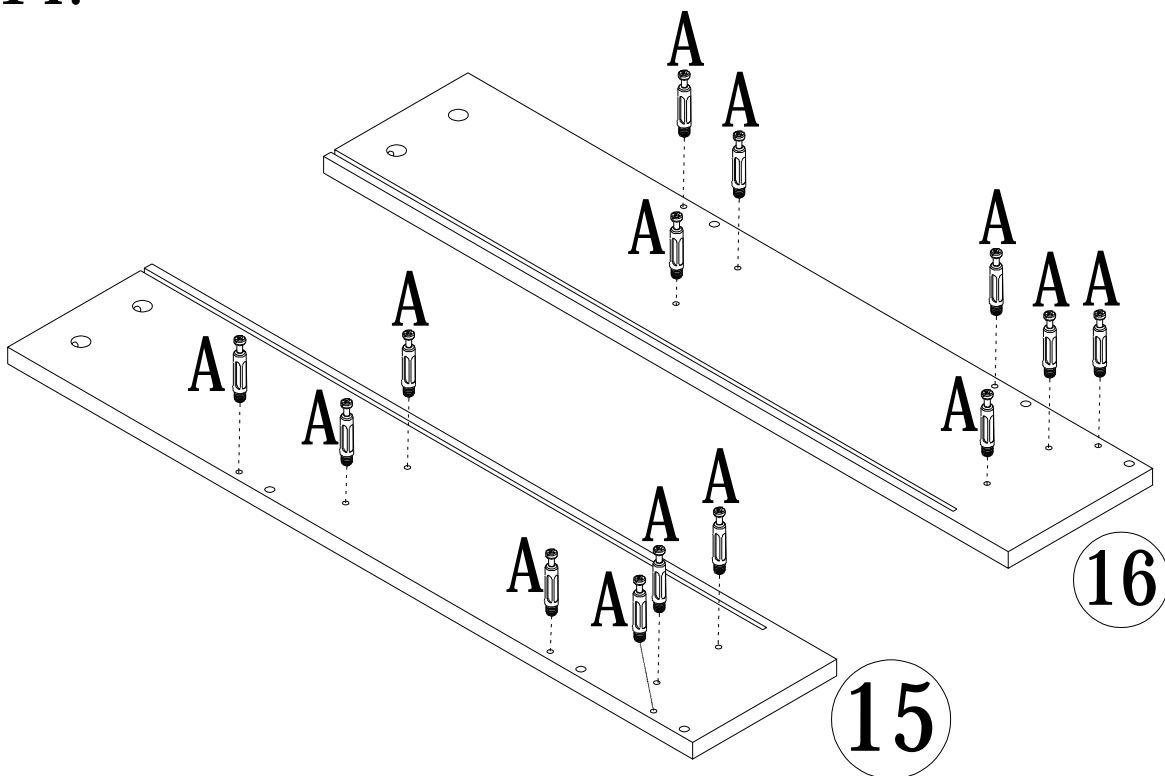

A  14PCS
--

15.

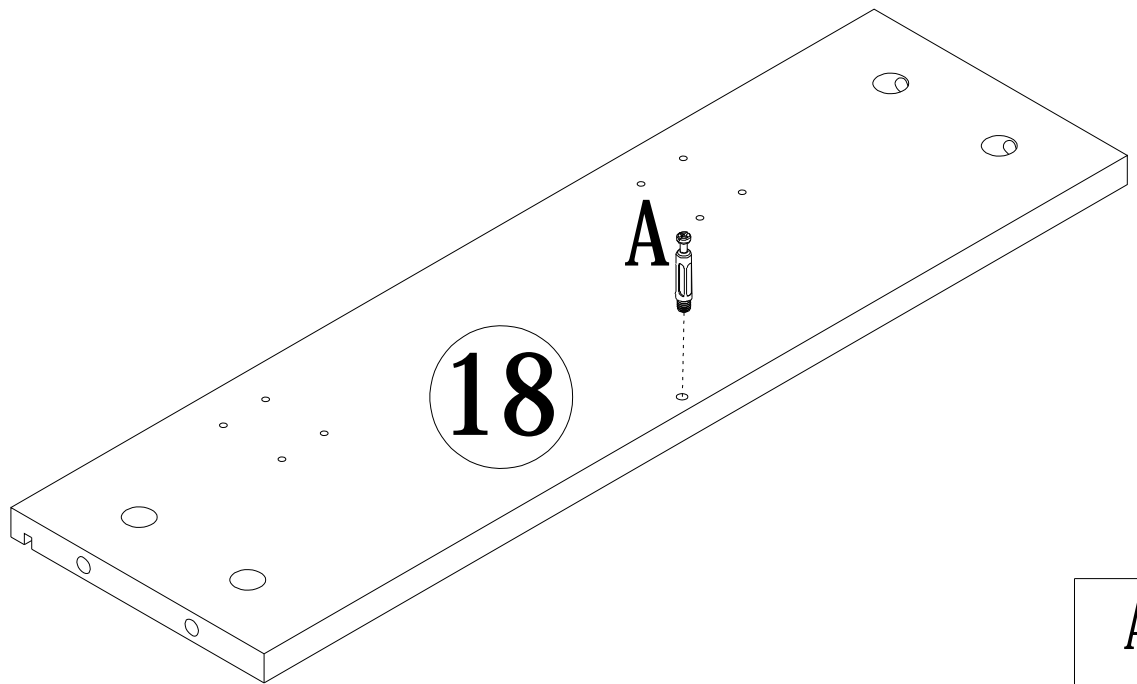

A



1PC

16.

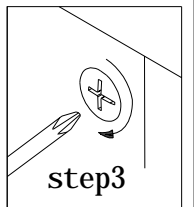
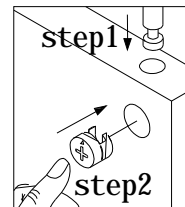
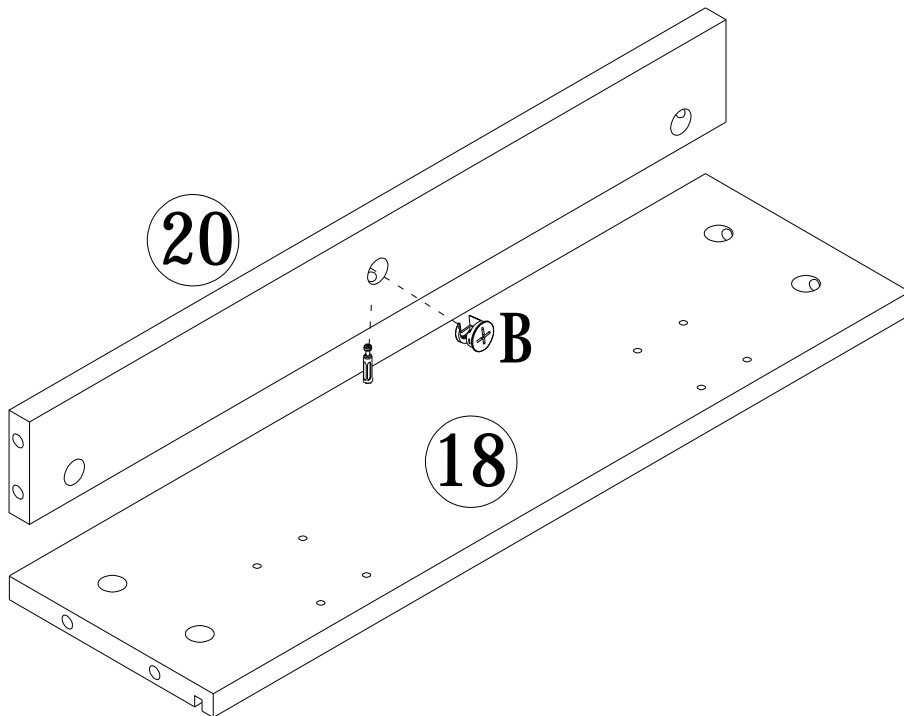



B



1PC

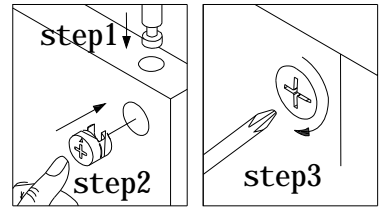
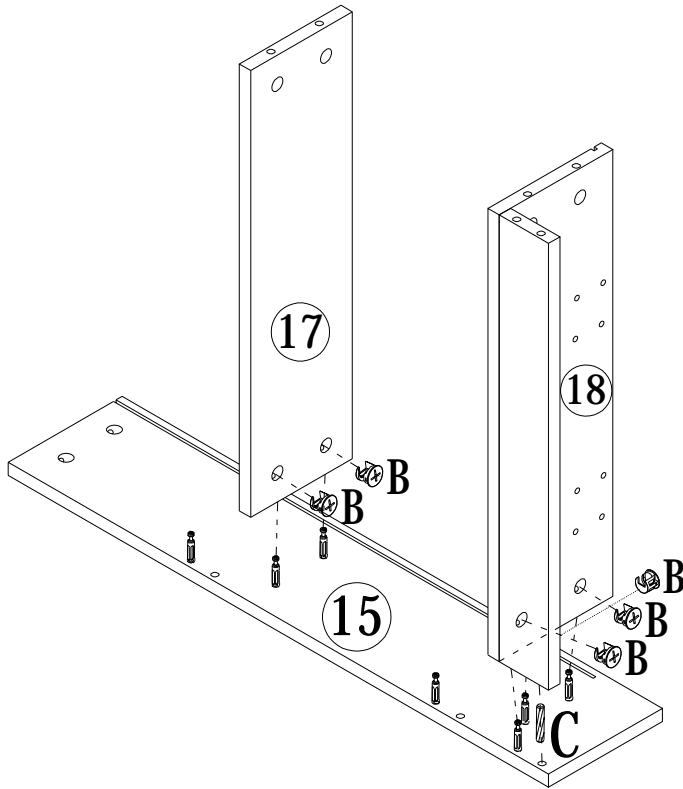

17.



B  5PCS	C  1PC
--	---

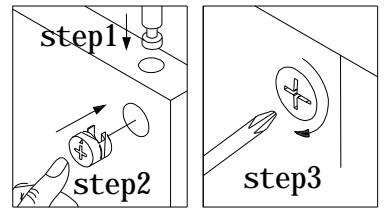
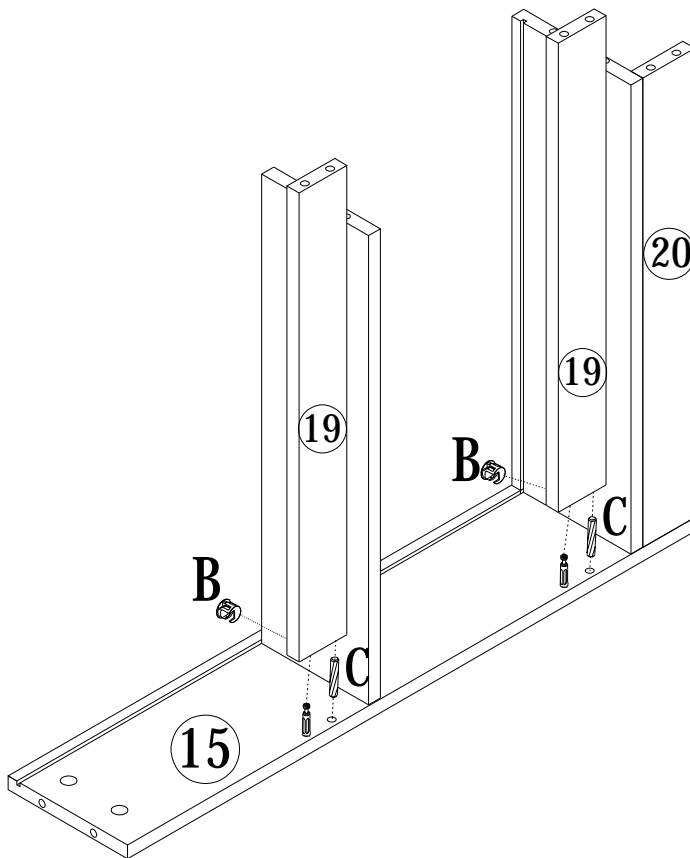

18.

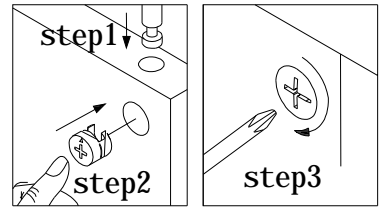
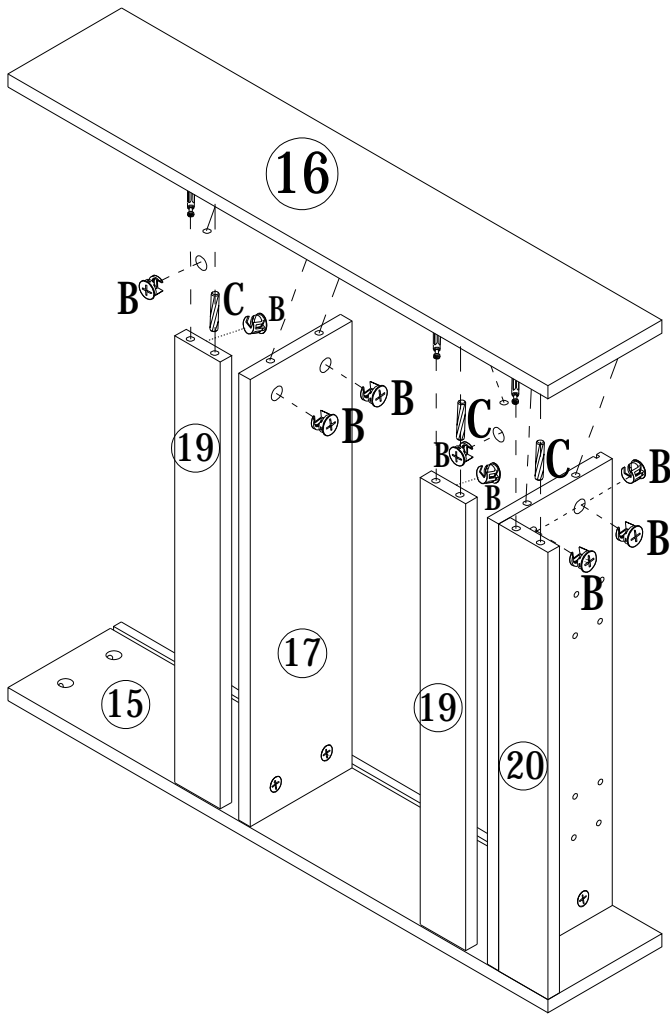

B  2PCS	C  2PCS
---	---

19.



B  7PCS	C  3PCS
---	---

20.

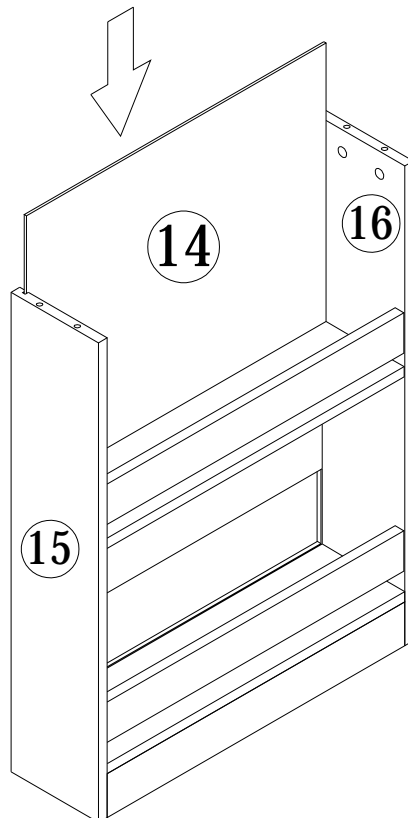

21.

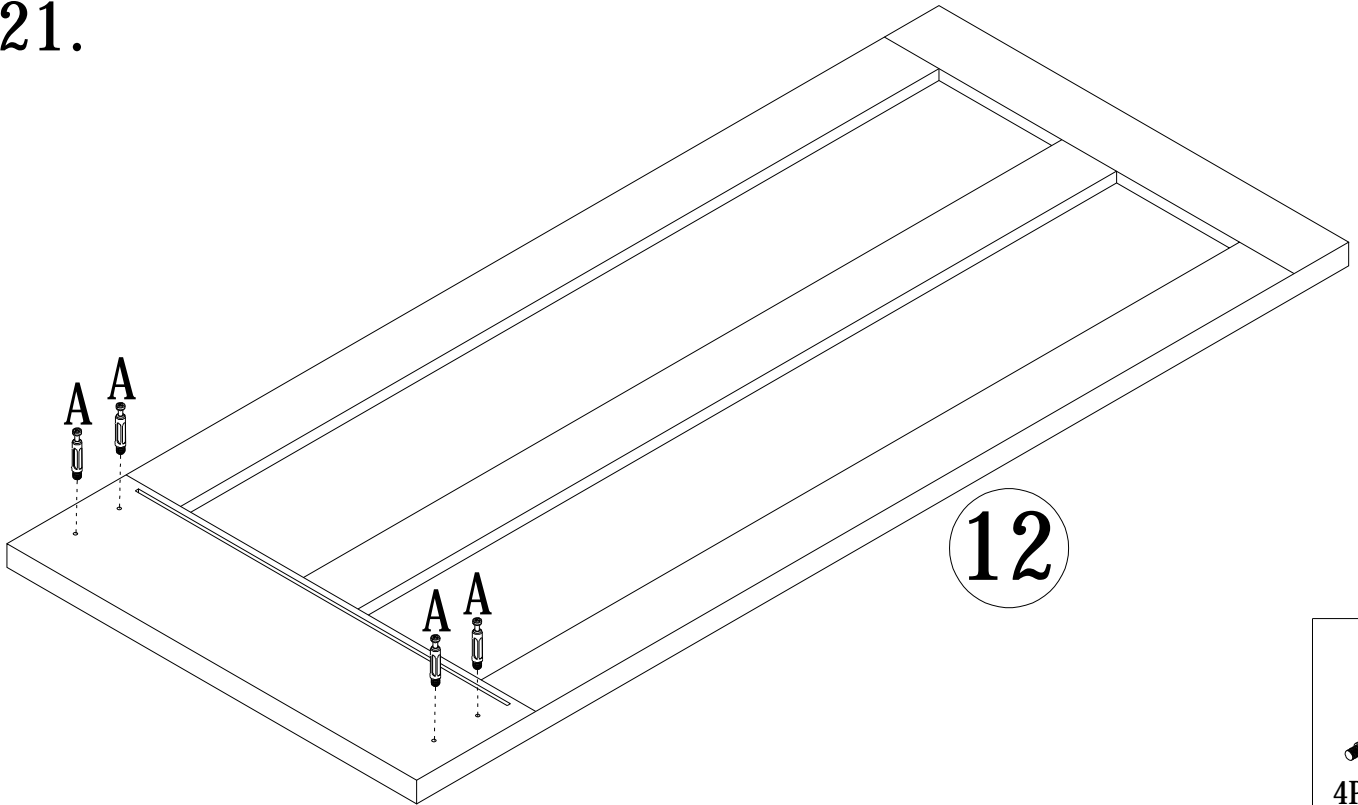

A



4PCS

22.

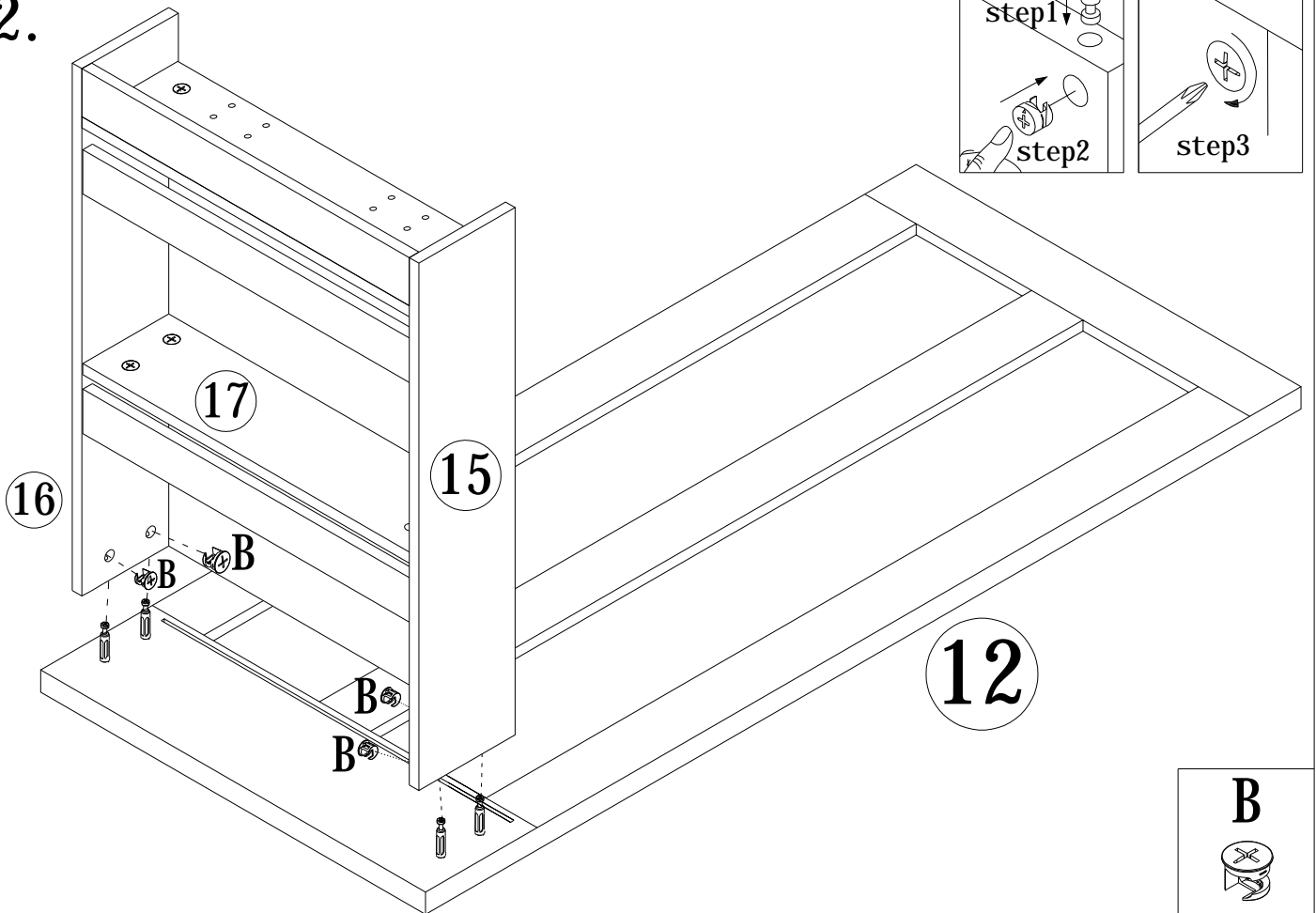

step1



step2

step3



B



4PCS

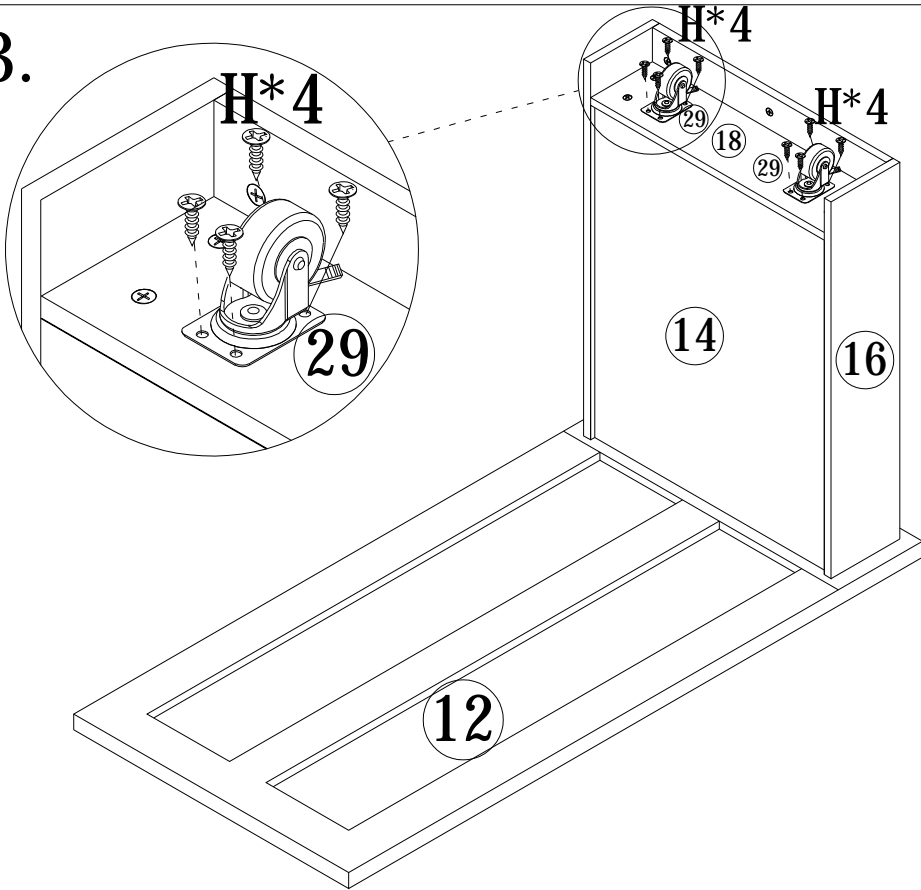

23.

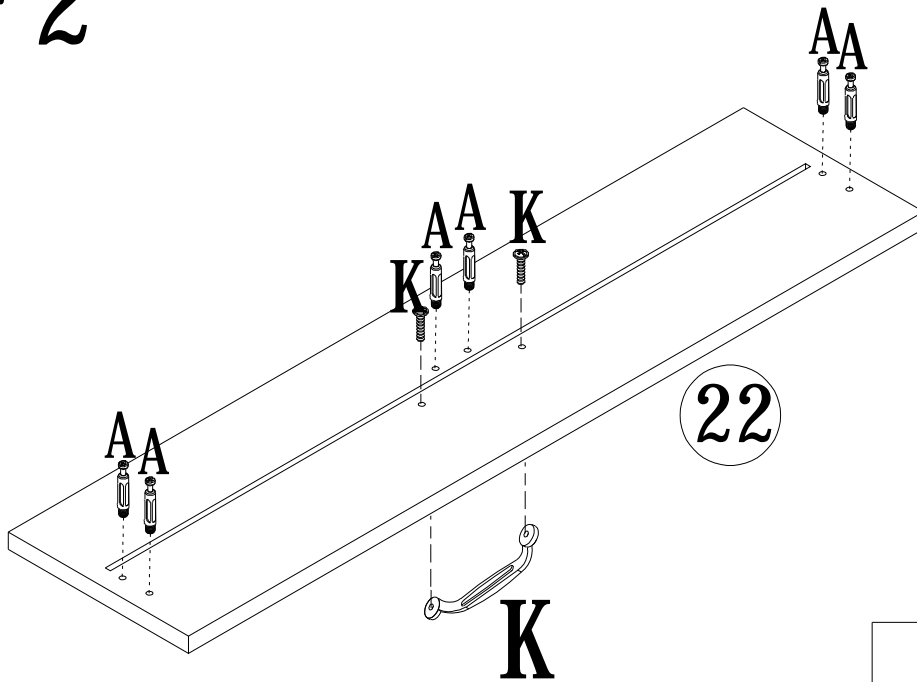

 <p>29 2PCS</p>	 <p>H 8PCS</p>
---	--

24. *2



 <p>A 12PCS</p>	 <p>K 2PCS</p>	 <p>K 4PCS</p>
--	---	---

25. *2

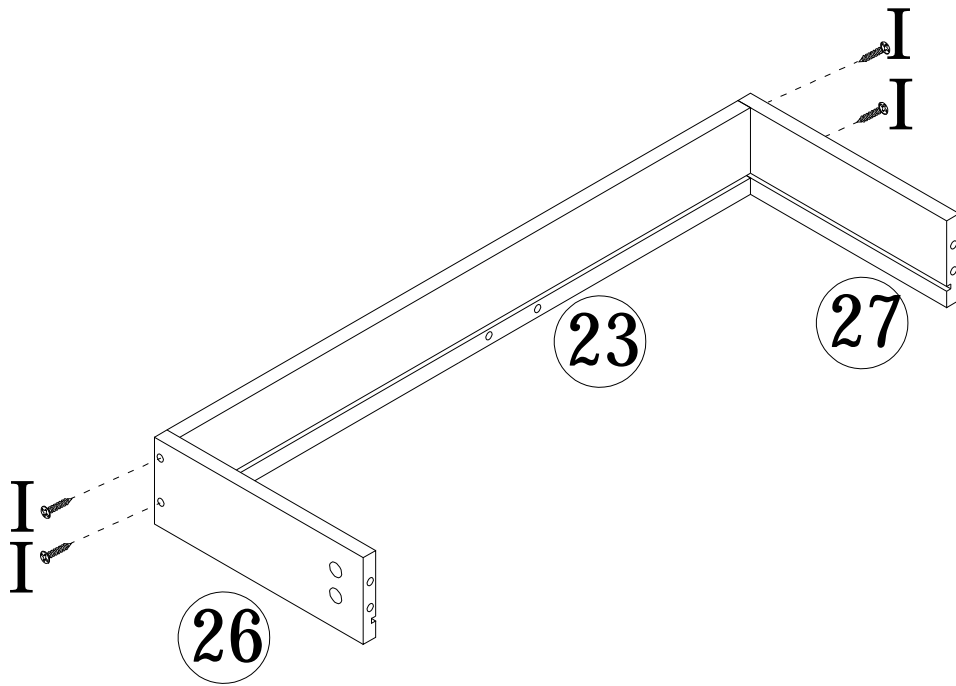

I
↓
8PCS

26. *2

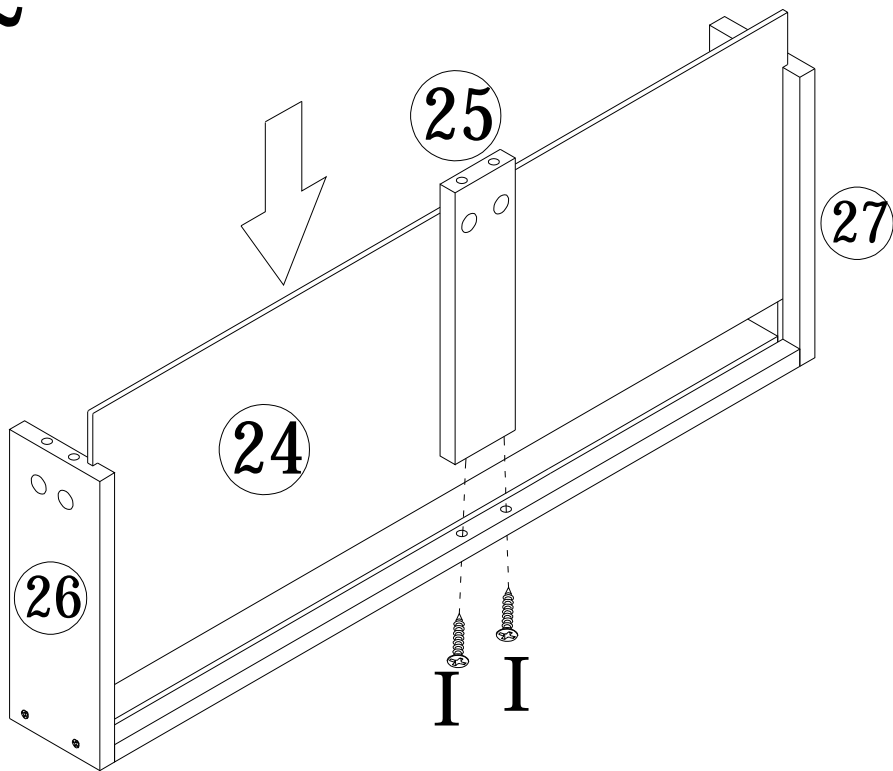

I
↓
4PCS

27. *2

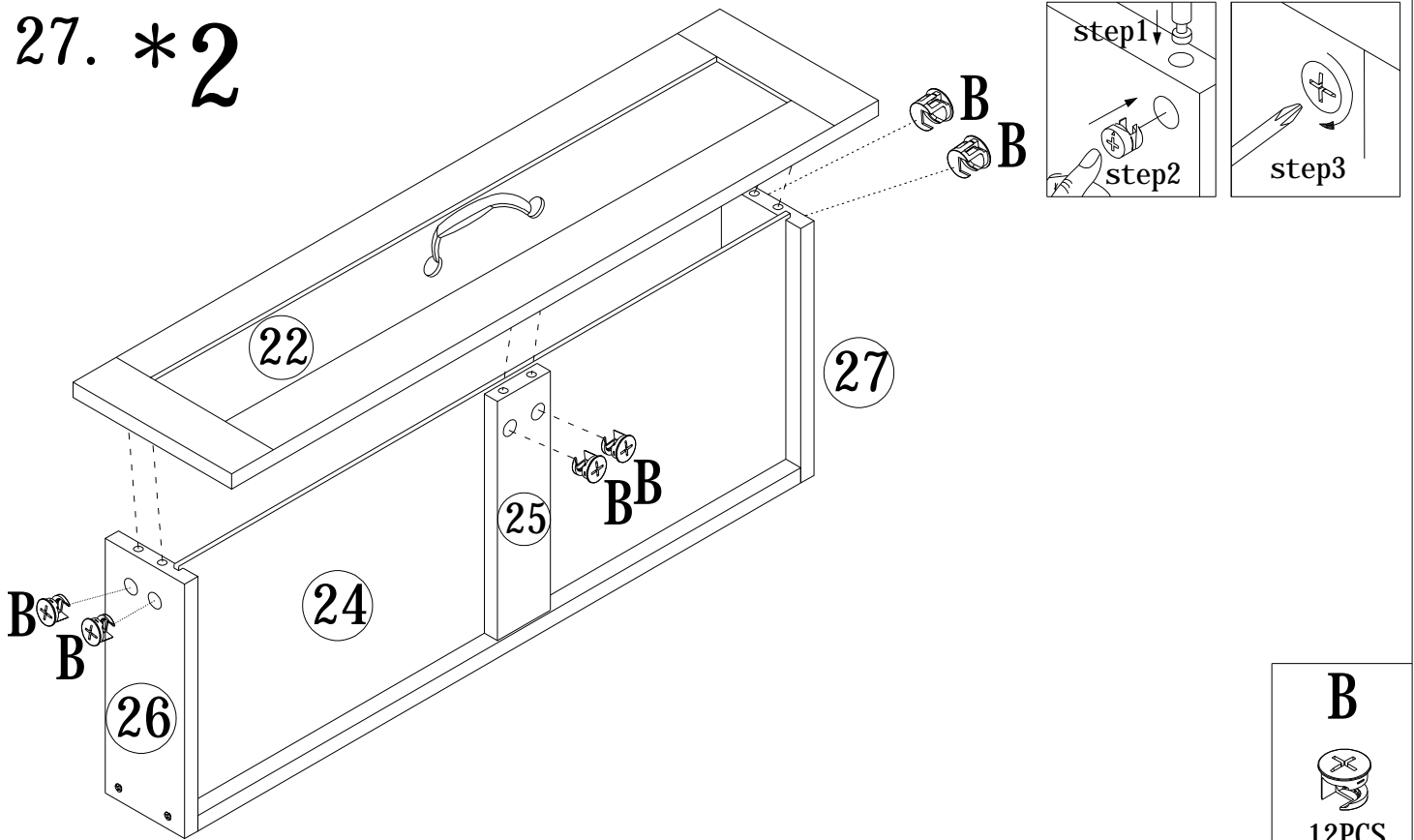

28. *2

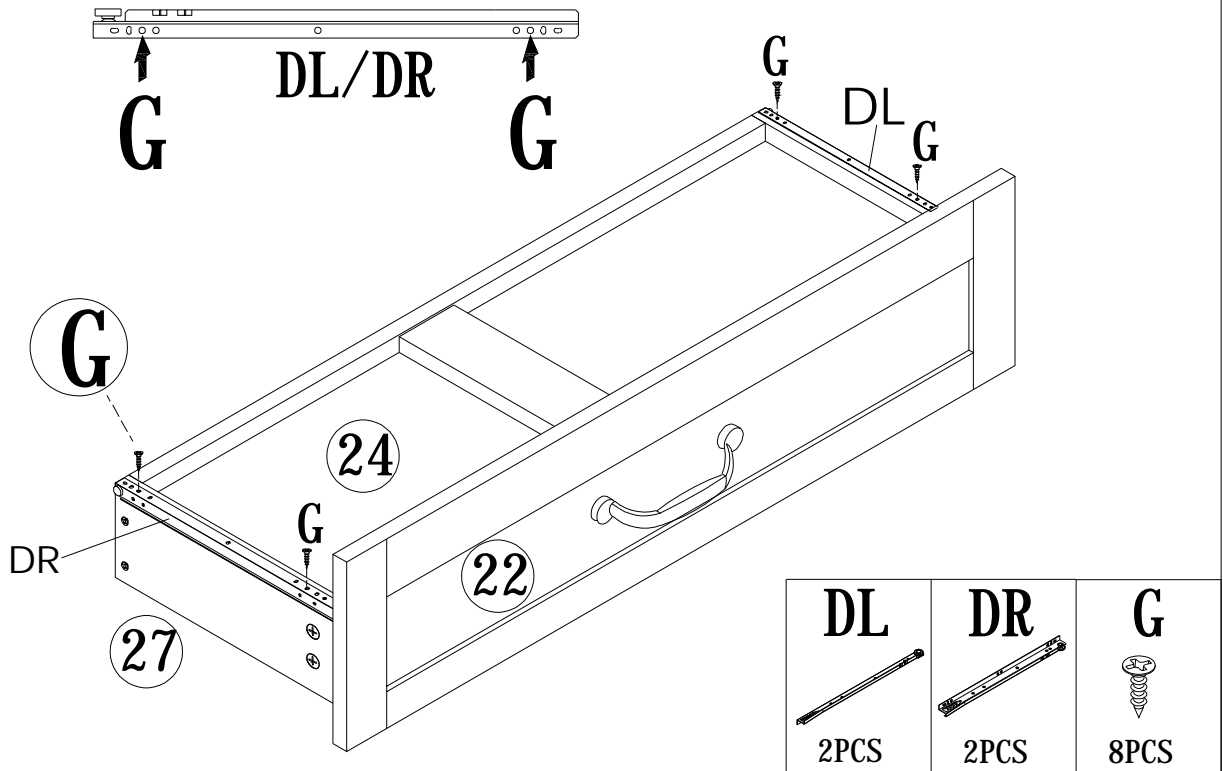

29.

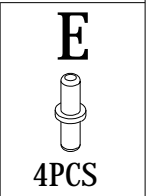
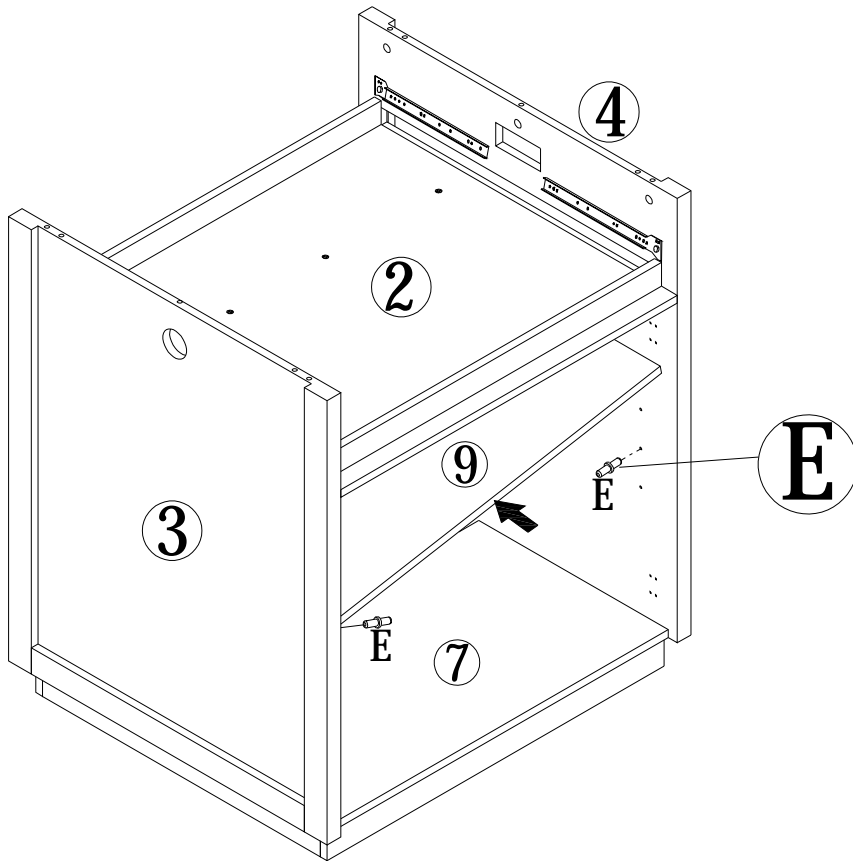

30. *2

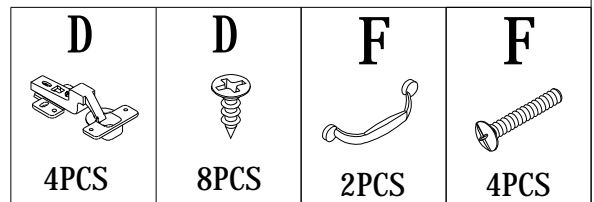
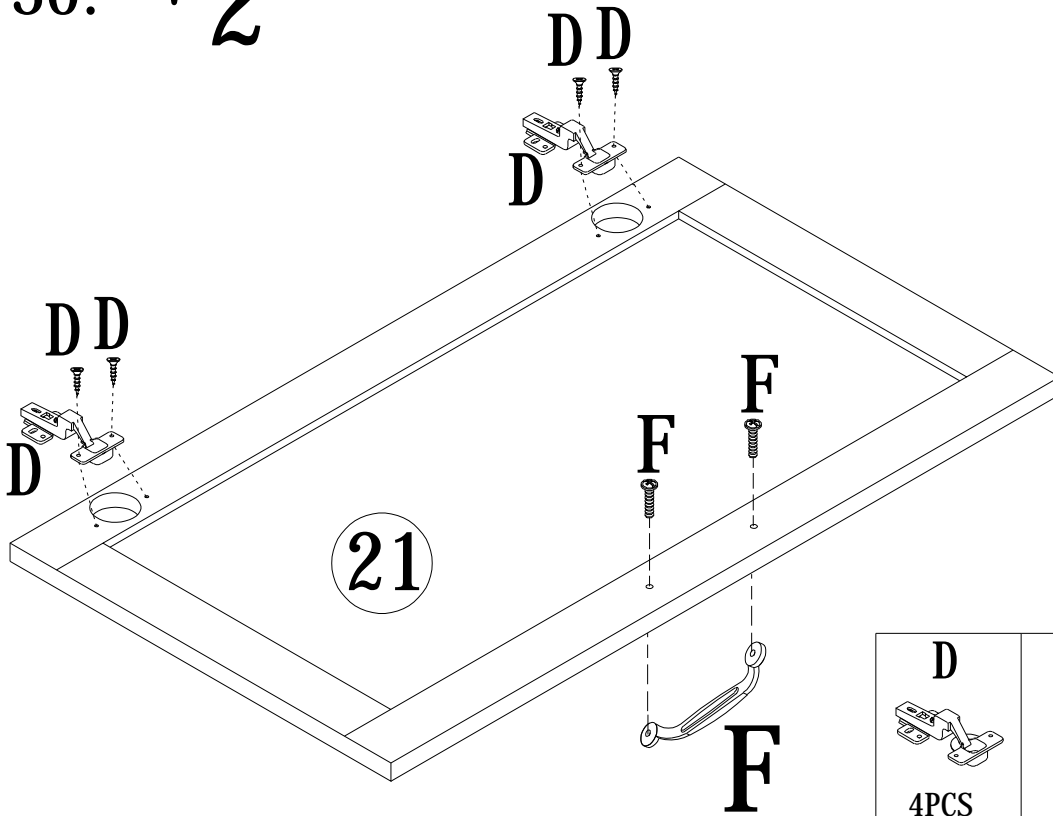

31.

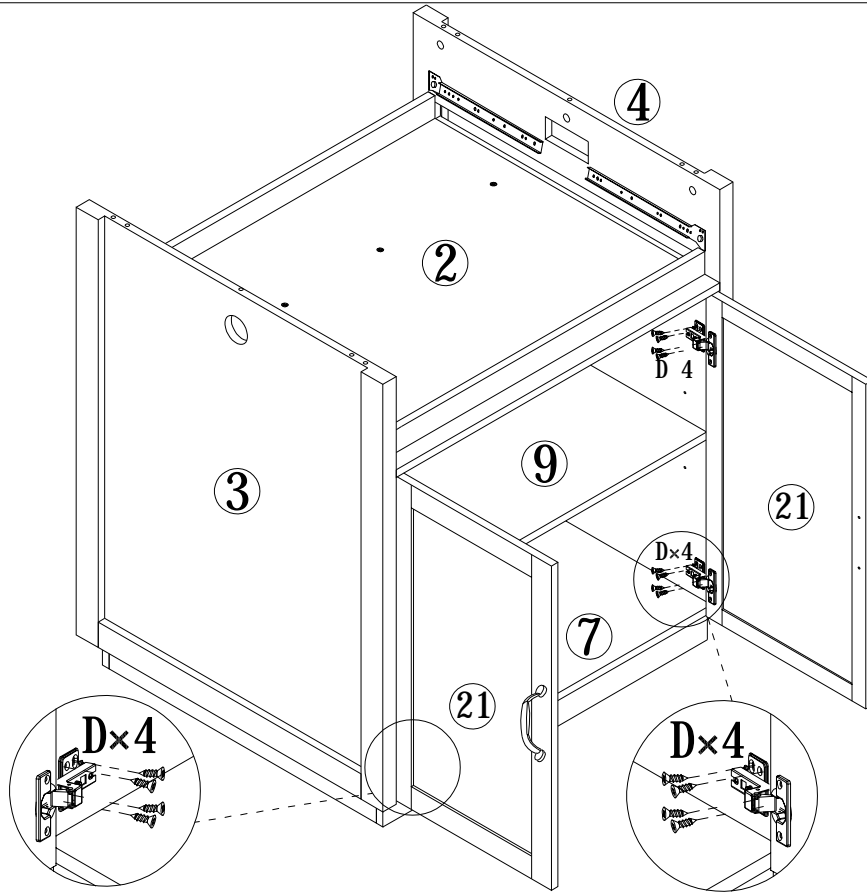
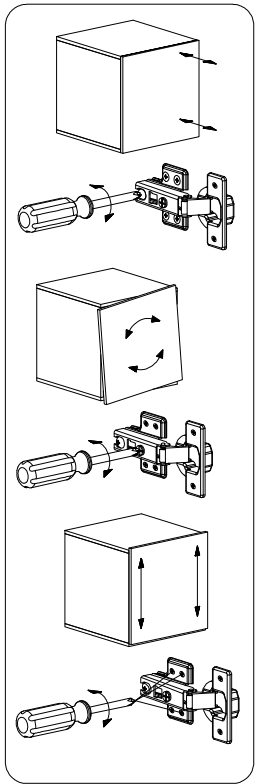

32.

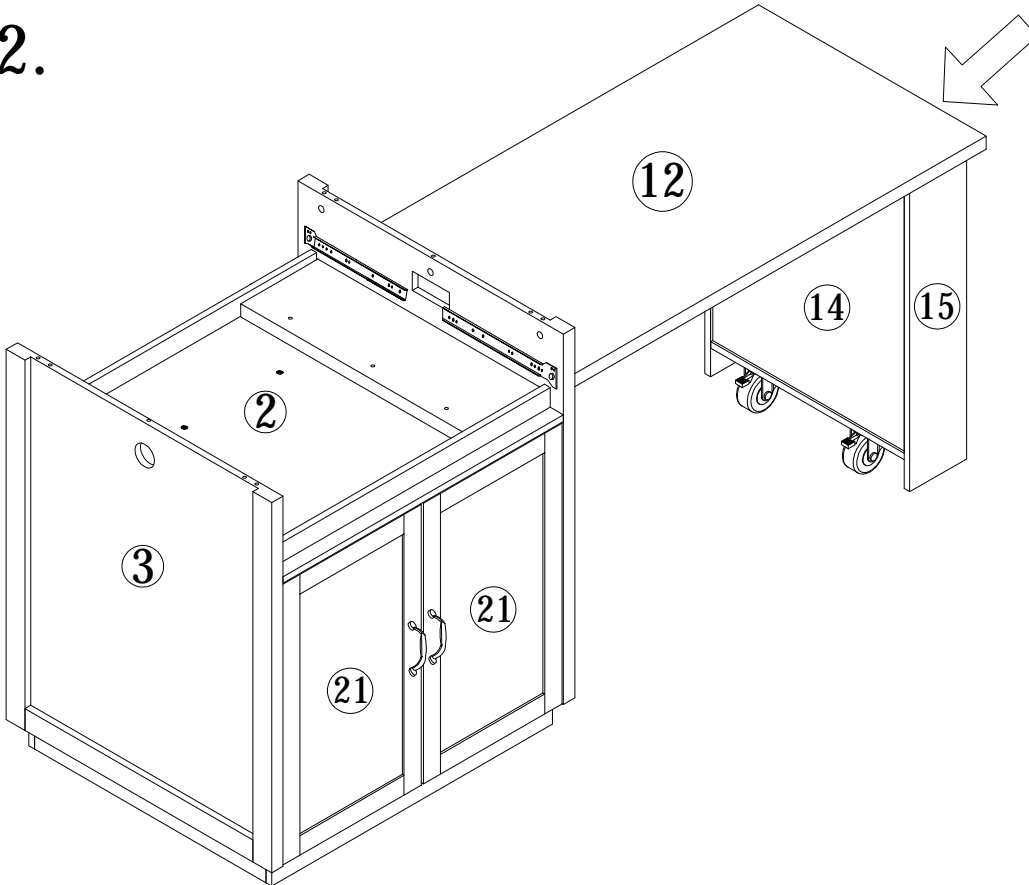

35.

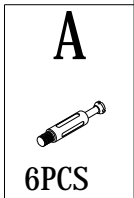
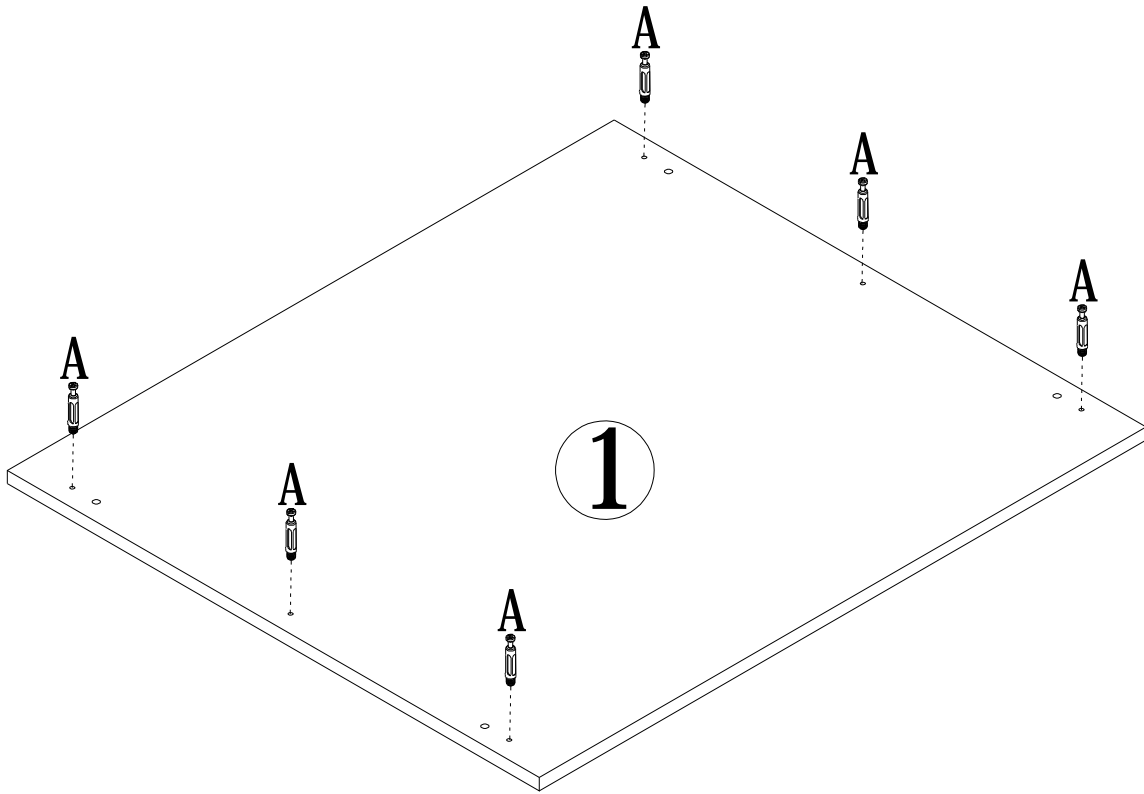

36.

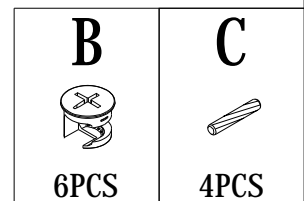
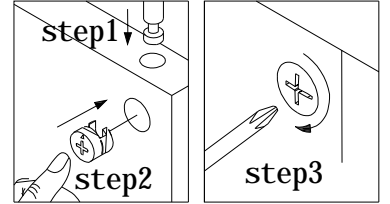
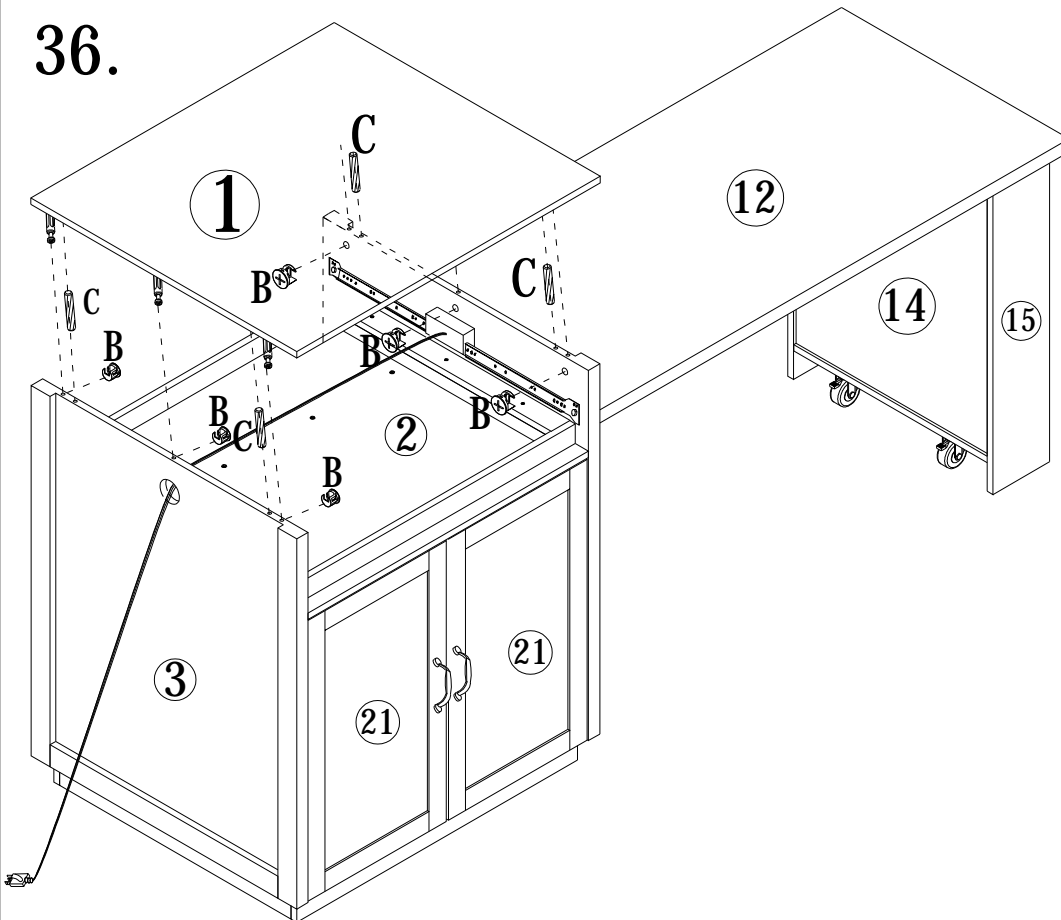

37.

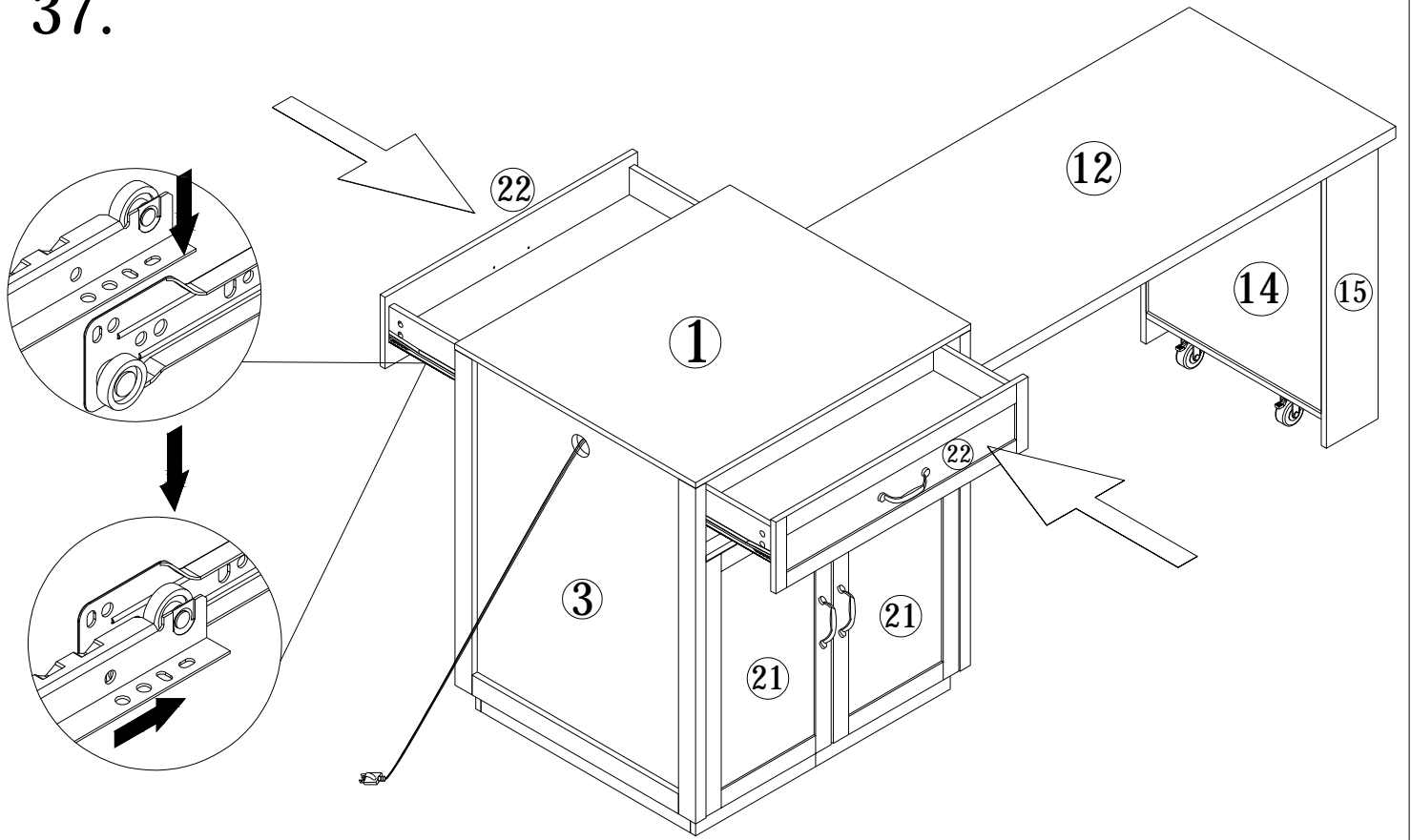

38.

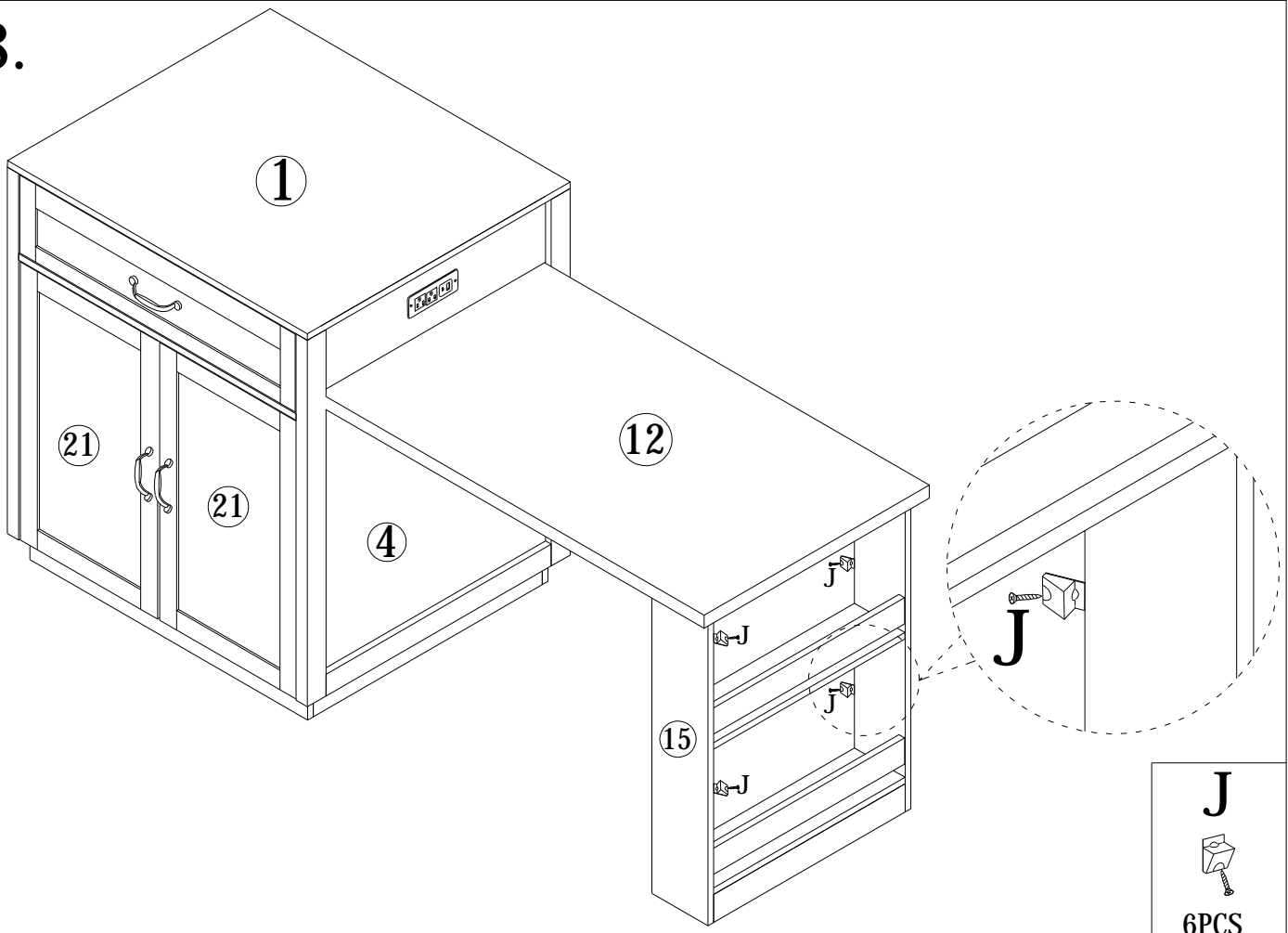

J

6PCS

39.

